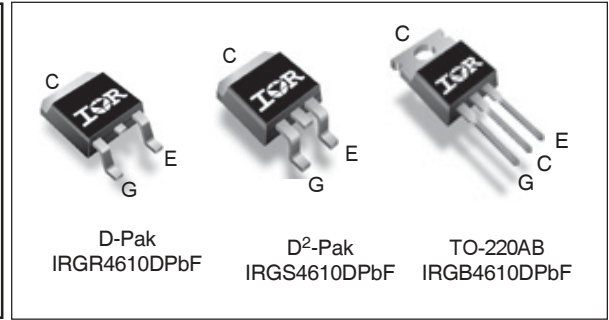
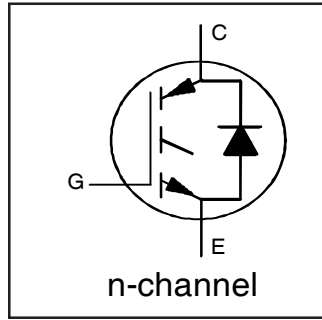


**Insulated Gate Bipolar Transistor with Ultrafast Soft Recovery Diode**

$V_{CES} = 600V$
$I_C = 10A, T_C = 100^\circ C$
$t_{sc} > 5\mu s, T_{jmax} = 175^\circ C$
$V_{CE(on)} \text{ typ.} = 1.7V @ 6A$



<b>G</b>	<b>C</b>	<b>E</b>
Gate	Collector	Emitter

**Applications**

- Appliance Drives
- Inverters
- UPS

Features	Benefits
Low $V_{CE(ON)}$ and switching losses	High efficiency in a wide range of applications and switching frequencies
Square RBSOA and maximum junction temperature $175^\circ C$	Improved reliability due to rugged hard switching performance and higher power capability
Positive $V_{CE(ON)}$ temperature coefficient and tighter distribution of parameters	Excellent current sharing in parallel operation
$5\mu s$ short circuit SOA	Enables short circuit protection scheme
Lead-free, RoHS compliant	Environmentally friendly

Base part number	Package Type	Standard Pack		Orderable Part Number
		Form	Quantity	
IRGR4610DPbF	D-PAK	Tube	75	IRGR4610DPbF
		Tape and Reel	2000	IRGR4610DTRPbF
		Tape and Reel Right	3000	IRGR4610DTRRPbF
		Tape and Reel Left	3000	IRGR4610DTRLpBf
IRGS4610DPbF	D² PAK	Tube	50	IRGS4610DPbF
		Tape and Reel Right	800	IRGS4610DTRRPbF
		Tape and Reel Left	800	IRGS4610DTRLpBf
IRGB4610DPbF	TO-220AB	Tube	50	IRGB4610DPbF

**Absolute Maximum Ratings**

	Parameter	Max.	Units
$V_{CES}$	Collector-to-Emitter Breakdown Voltage	600	V
$I_C @ T_C = 25^\circ C$	Continuous Collector Current	16	A
$I_C @ T_C = 100^\circ C$	Continuous Collector Current	10	
$I_{CM}$	Pulsed Collector Current, $V_{GE} = 15V$	18	
$I_{LM}$	Clamped Inductive Load Current, $V_{GE} = 20V \text{ ①}$	24	
$I_F @ T_C = 25^\circ C$	Diode Continuous Forward Current	10	
$I_F @ T_C = 100^\circ C$	Diode Continuous Forward Current	6	
$I_{FM}$	Diode Maximum Forward Current ④	24	
$V_{GE}$	Continuous Gate-to-Emitter Voltage	$\pm 20$	V
	Transient Gate-to-Emitter Voltage	$\pm 30$	
$P_D @ T_C = 25^\circ$	Maximum Power Dissipation	77	W
		$P_D @ T_C = 100^\circ$	
$T_J$	Operating Junction and Storage Temperature Range	-40 to + 175	$^\circ C$
$T_{STG}$			
	Soldering Temperature, for 10 seconds (1.6mm from case)	300	
	Mounting Torque, 6-32 or M3 Screw TO-220	10lbf. In (1.1 N.m)	

**Thermal Resistance**

	Parameter	Min.	Typ.	Max.	Units
$R_{\theta JC}$	Thermal Resistance, Junction-to-Case -(IGBT)②	—	—	1.9	°C/W
$R_{\theta JC}$	Thermal Resistance, Junction-to-Case -(Diode)②	—	—	6.3	
$R_{\theta CS}$	Thermal Resistance, Case-to-Sink (flat, greased surface) (TO-220)	—	0.5	—	
$R_{\theta JA}$	Thermal Resistance, Junction-to-Ambient (PCB mount) (D-PAK)⑥	—	—	50	
	Thermal Resistance, Junction-to-Ambient (D-PAK)	—	—	110	
	Thermal Resistance, Junction-to-Ambient (PCB mount, Steady State) (D <sup>2</sup> PAK)⑥	—	—	40	
	Thermal Resistance, Junction-to-Ambient ( Socket mount) (TO-220)	—	—	62	

**Electrical Characteristics @  $T_J = 25^\circ\text{C}$  (unless otherwise specified)**

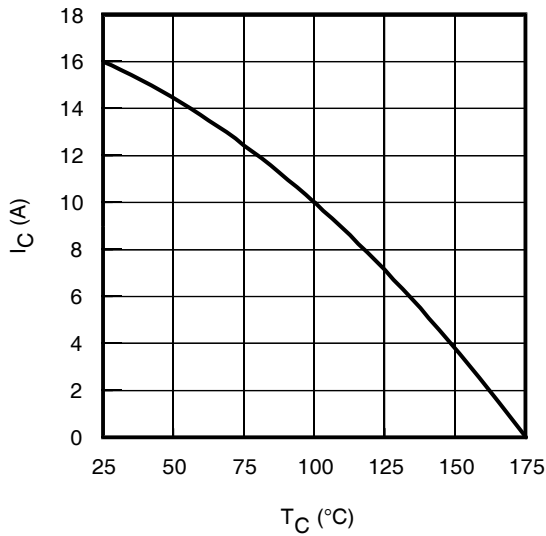
	Parameter	Min.	Typ.	Max.	Units	Conditions
$V_{(BR)CES}$	Collector-to-Emitter Breakdown Voltage	600	—	—	V	$V_{GE} = 0V, I_C = 100 \mu A$ ③
$\Delta V_{(BR)CES}/\Delta T_J$	Temperature Coeff. of Breakdown Voltage	—	0.36	—	V/°C	$V_{GE} = 0V, I_C = 250 \mu A$ ( 25 -175 °C )
$V_{CE(on)}$	Collector-to-Emitter Saturation Voltage	—	1.7	2.0	V	$I_C = 6.0A, V_{GE} = 15V, T_J = 25^\circ\text{C}$
		—	2.07	—		$I_C = 6.0A, V_{GE} = 15V, T_J = 150^\circ\text{C}$
		—	2.14	—		$I_C = 6.0A, V_{GE} = 15V, T_J = 175^\circ\text{C}$
$V_{GE(th)}$	Gate Threshold Voltage	4.0	—	6.5	V	$V_{CE} = V_{GE}, I_C = 150 \mu A$
$\Delta V_{GE(th)}/\Delta T_J$	Threshold Voltage temp. coefficient	—	-13	—	mV/°C	$V_{CE} = V_{GE}, I_C = 250 \mu A$ ( 25 -175 °C )
$g_{fe}$	Forward Transconductance	—	5.8	—	S	$V_{CE} = 25V, I_C = 6.0A, PW = 80 \mu S$
$I_{CES}$	Collector-to-Emitter Leakage Current	—	—	25	$\mu A$	$V_{GE} = 0V, V_{CE} = 600V$
		—	—	250		$V_{GE} = 0V, V_{CE} = 600V, T_J = 175^\circ\text{C}$
$V_{FM}$	Diode Forward Voltage Drop	—	1.60	2.30	V	$I_F = 6.0A$
		—	1.30	—		$I_F = 6.0A, T_J = 175^\circ\text{C}$
$I_{GES}$	Gate-to-Emitter Leakage Current	—	—	$\pm 100$	nA	$V_{GE} = \pm 20 V$

**Notes:**

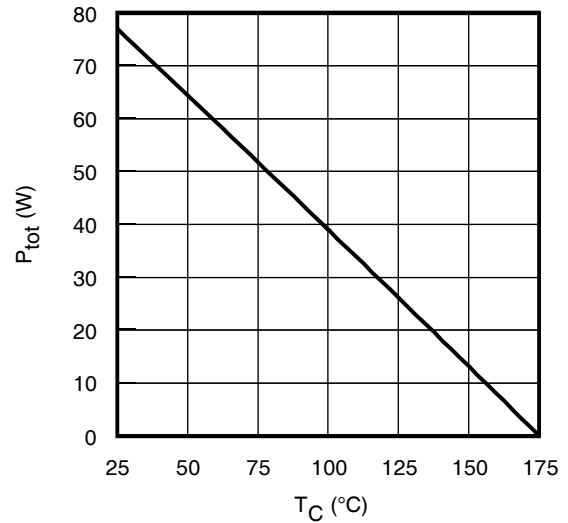
- ①  $V_{CC} = 80\% (V_{CES}), V_{GE} = 20V, L = 1.0mH, R_G = 100\Omega$ .
- ②  $R_{\theta}$  is measured at  $T_J$  approximately  $90^\circ\text{C}$ .
- ③ Refer to AN-1086 for guidelines for measuring  $V_{(BR)CES}$  safely.
- ④ Pulse width limited by max. junction temperature.
- ⑤ Values influenced by parasitic L and C in measurement
- ⑥ When mounted on 1" square PCB (FR-4 or G-10 Material). For recommended footprint and soldering techniques refer to application note #AN-994: <http://www.irf.com/technical-info/appnotes/an-994.pdf>

**Switching Characteristics @  $T_J = 25^\circ\text{C}$  (unless otherwise specified)**

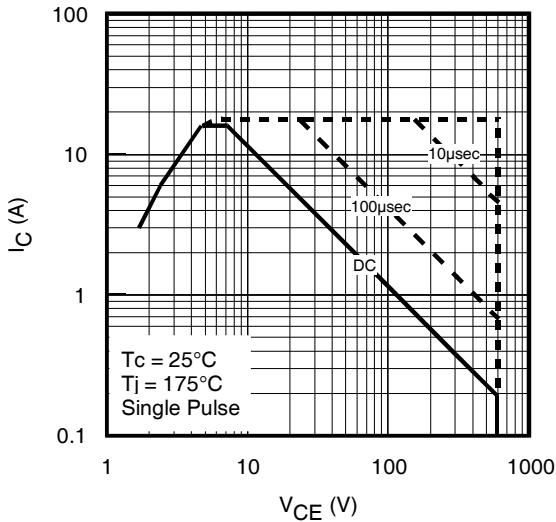
	Parameter	Min.	Typ.	Max.	Units	Conditions
$Q_g$	Total Gate Charge (turn-on)	—	13	—	nC	$I_C = 6.0\text{A}$ $V_{CC} = 400\text{V}$ $V_{GE} = 15\text{V}$
$Q_{ge}$	Gate-to-Emitter Charge (turn-on)	—	3.0	—		
$Q_{gc}$	Gate-to-Collector Charge (turn-on)	—	6.4	—		
$E_{on}$	Turn-On Switching Loss	—	56	—	$\mu\text{J}$	$I_C = 6.0\text{A}$ , $V_{CC} = 400\text{V}$ , $V_{GE} = 15\text{V}$ $R_G = 47\Omega$ , $L = 1\text{mH}$ , $L_S = 150\text{nH}$ , $T_J = 25^\circ\text{C}$ Energy losses include tail and diode reverse recovery
$E_{off}$	Turn-Off Switching Loss	—	122	—		
$E_{total}$	Total Switching Loss	—	178	—		
$t_{d(on)}$	Turn-On delay time	—	27	—	ns	$I_C = 6.0\text{A}$ , $V_{CC} = 400\text{V}$ $R_G = 47\Omega$ , $L = 1\text{mH}$ , $L_S = 150\text{nH}$ $T_J = 25^\circ\text{C}$ Ⓢ
$t_r$	Rise time	—	11	—		
$t_{d(off)}$	Turn-Off delay time	—	75	—		
$t_f$	Fall time	—	17	—		
$E_{on}$	Turn-On Switching Loss	—	140	—	$\mu\text{J}$	$I_C = 6.0\text{A}$ , $V_{CC} = 400\text{V}$ , $V_{GE} = 15\text{V}$ $R_G = 47\Omega$ , $L = 1\text{mH}$ , $L_S = 150\text{nH}$ , $T_J = 175^\circ\text{C}$ Energy losses include tail and diode reverse recovery
$E_{off}$	Turn-Off Switching Loss	—	189	—		
$E_{total}$	Total Switching Loss	—	329	—		
$t_{d(on)}$	Turn-On delay time	—	26	—	ns	$I_C = 6.0\text{A}$ , $V_{CC} = 400\text{V}$ $R_G = 47\Omega$ , $L = 1\text{mH}$ , $L_S = 150\text{nH}$ $T_J = 175^\circ\text{C}$ Ⓢ
$t_r$	Rise time	—	12	—		
$t_{d(off)}$	Turn-Off delay time	—	95	—		
$t_f$	Fall time	—	32	—		
$C_{ies}$	Input Capacitance	—	350	—	pF	$V_{GE} = 0\text{V}$ $V_{CC} = 30\text{V}$ $f = 1\text{Mhz}$
$C_{oes}$	Output Capacitance	—	29	—		
$C_{res}$	Reverse Transfer Capacitance	—	10	—		
RBSOA	Reverse Bias Safe Operating Area	FULL SQUARE				$T_J = 175^\circ\text{C}$ , $I_C = 24\text{A}$ $V_{CC} = 500\text{V}$ , $V_p = 600\text{V}$ $R_G = 100\Omega$ , $V_{GE} = +20\text{V}$ to $0\text{V}$
SCSOA	Short Circuit Safe Operating Area	5	—	—	$\mu\text{s}$	$V_{CC} = 400\text{V}$ , $V_p = 600\text{V}$ $R_G = 100\Omega$ , $V_{GE} = +15\text{V}$ to $0\text{V}$
Erec	Reverse recovery energy of the diode	—	178	—	$\mu\text{J}$	$T_J = 175^\circ\text{C}$
$t_{rr}$	Diode Reverse recovery time	—	74	—	ns	$V_{CC} = 400\text{V}$ , $I_F = 6.0\text{A}$
$I_{rr}$	Peak Reverse Recovery Current	—	12	—	A	$V_{GE} = 15\text{V}$ , $R_g = 47\Omega$ , $L = 1\text{mH}$ , $L_S = 150\text{nH}$



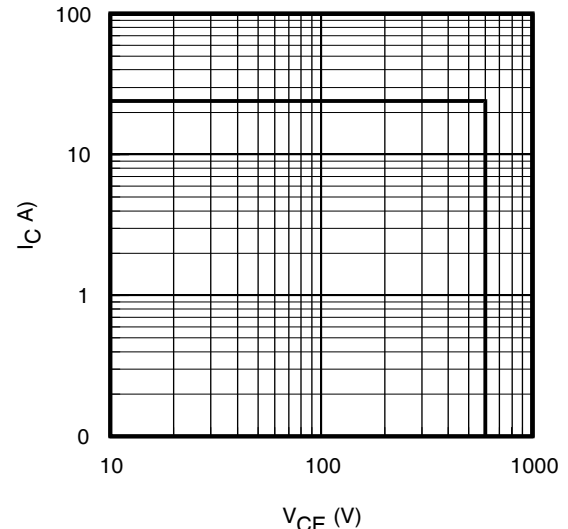
**Fig. 1** - Maximum DC Collector Current vs. Case Temperature



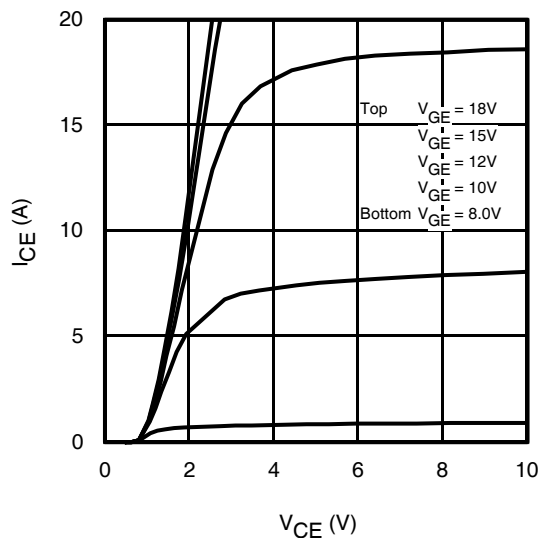
**Fig. 2** - Power Dissipation vs. Case Temperature



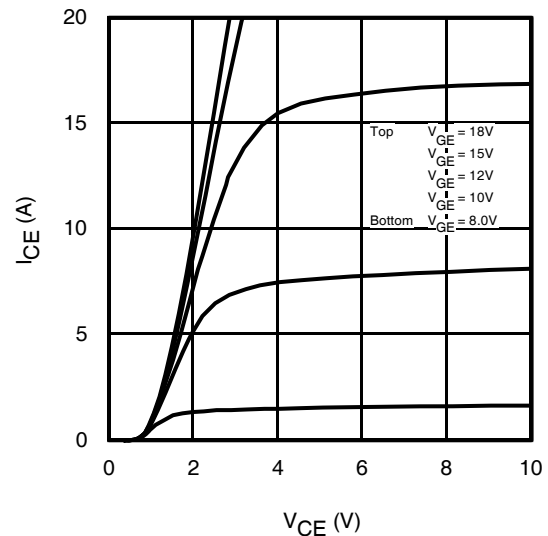
**Fig. 3** - Forward SOA,  
 $T_C = 25^\circ\text{C}$ ,  $T_J \leq 175^\circ\text{C}$ ,  $V_{GE} = 15\text{V}$



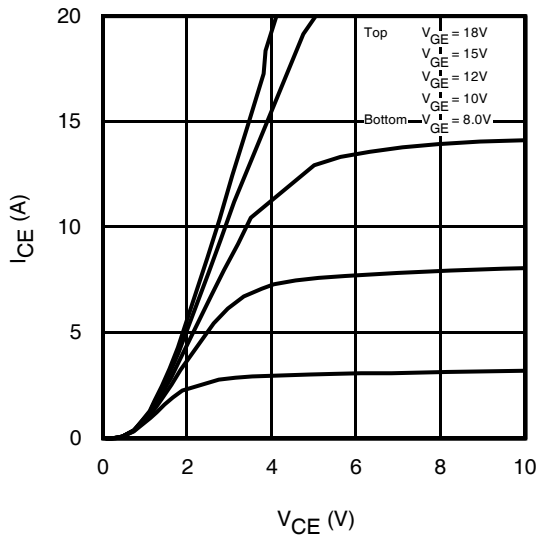
**Fig. 4** - Reverse Bias SOA  
 $T_J = 175^\circ\text{C}$ ,  $V_{GE} = 20\text{V}$



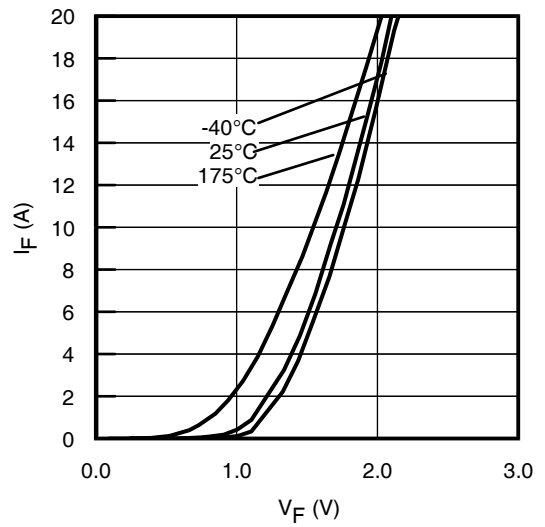
**Fig. 5** - Typ. IGBT Output Characteristics  
 $T_J = -40^\circ\text{C}$ ;  $t_p = 80\mu\text{s}$



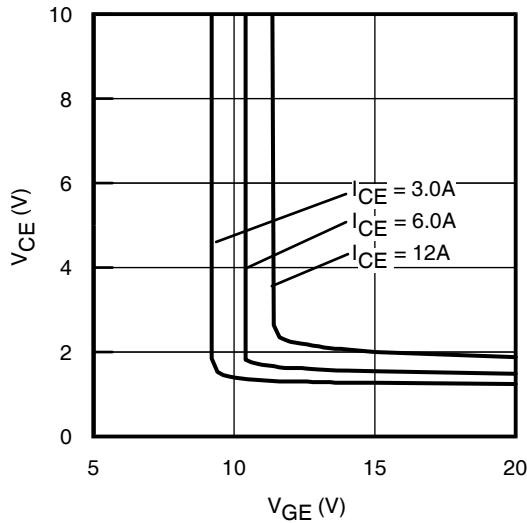
**Fig. 6** - Typ. IGBT Output Characteristics  
 $T_J = 25^\circ\text{C}$ ;  $t_p = 80\mu\text{s}$



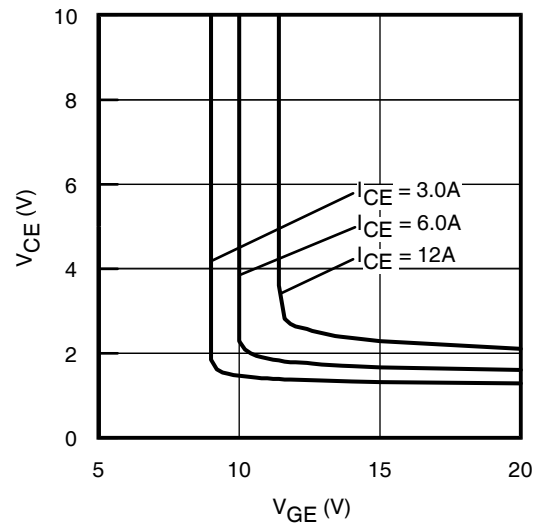
**Fig. 7 - Typ. IGBT Output Characteristics**  
 $T_J = 175^\circ\text{C}$ ;  $t_p = 80\mu\text{s}$



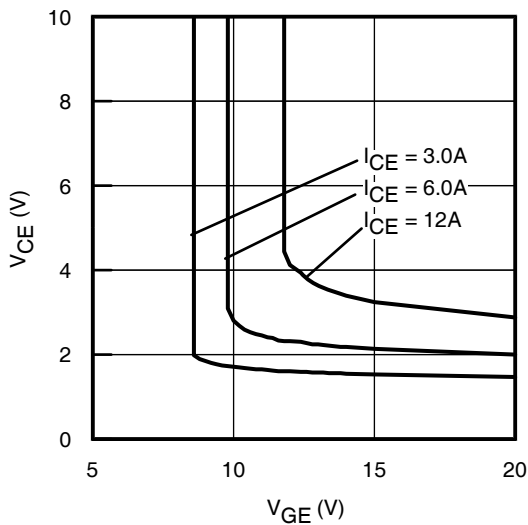
**Fig. 8 - Typ. Diode Forward Characteristics**  
 $t_p = 80\mu\text{s}$



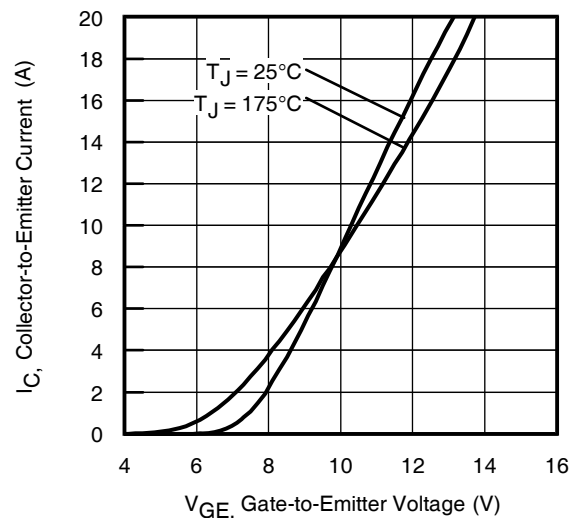
**Fig. 9 - Typical  $V_{CE}$  vs.  $V_{GE}$**   
 $T_J = -40^\circ\text{C}$



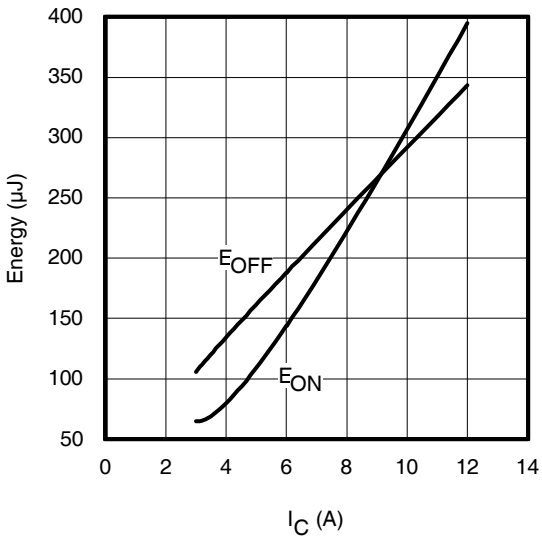
**Fig. 10 - Typical  $V_{CE}$  vs.  $V_{GE}$**   
 $T_J = 25^\circ\text{C}$



**Fig. 11 - Typical  $V_{CE}$  vs.  $V_{GE}$**   
 $T_J = 175^\circ\text{C}$

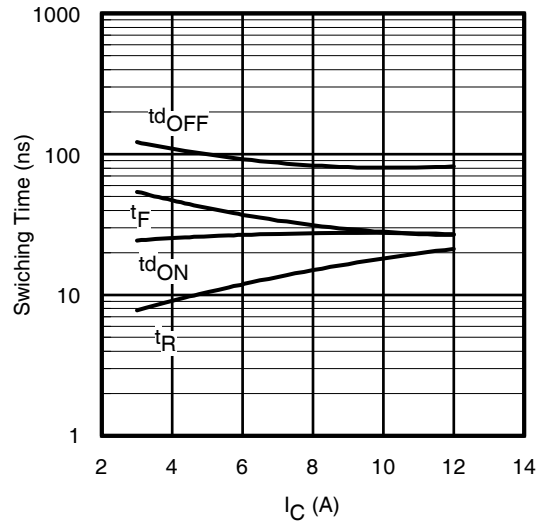


**Fig. 12 - Typ. Transfer Characteristics**  
 $V_{CE} = 50\text{V}$ ;  $t_p = 10\mu\text{s}$



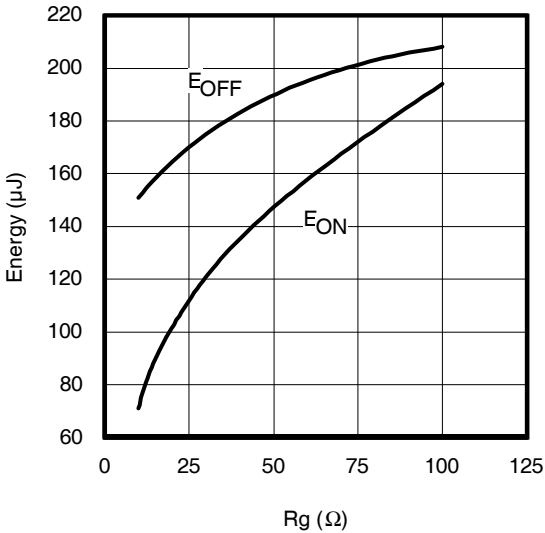
**Fig. 13** - Typ. Energy Loss vs.  $I_C$

$T_J = 175^\circ\text{C}$ ;  $L = 1\text{mH}$ ;  $V_{CE} = 400\text{V}$ ;  $R_G = 47\Omega$ ;  $V_{GE} = 15\text{V}$ .



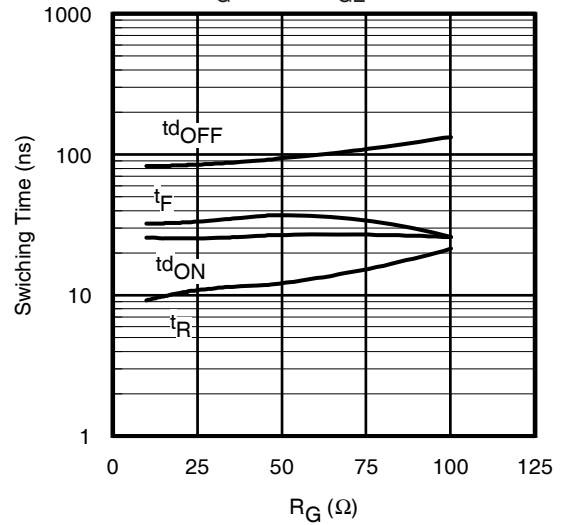
**Fig. 14** - Typ. Switching Time vs.  $I_C$

$T_J = 175^\circ\text{C}$ ;  $L = 1\text{mH}$ ;  $V_{CE} = 400\text{V}$   
 $R_G = 47\Omega$ ;  $V_{GE} = 15\text{V}$



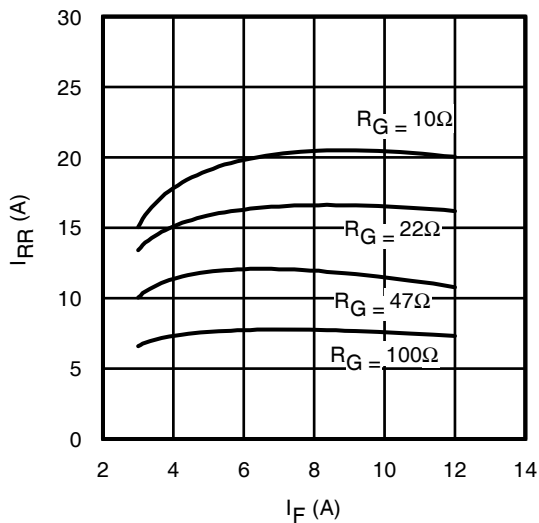
**Fig. 15** - Typ. Energy Loss vs.  $R_G$

$T_J = 175^\circ\text{C}$ ;  $L = 1\text{mH}$ ;  $V_{CE} = 400\text{V}$ ;  $I_{CE} = 6.0\text{A}$ ;  $V_{GE} = 15\text{V}$

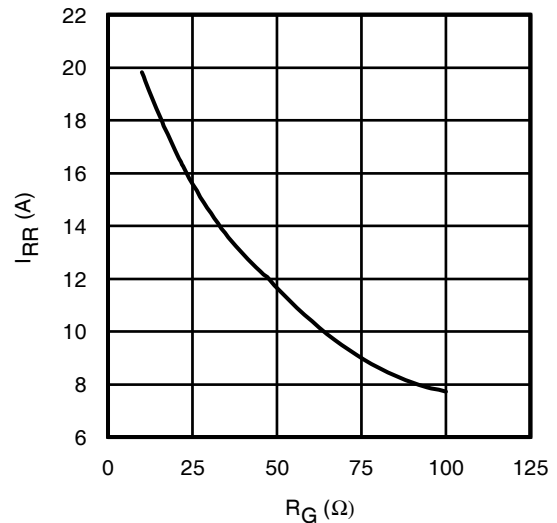


**Fig. 16** - Typ. Switching Time vs.  $R_G$

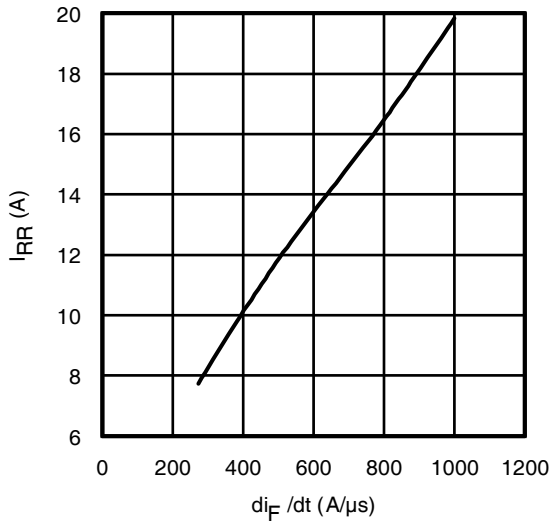
$T_J = 175^\circ\text{C}$ ;  $L = 1\text{mH}$ ;  $V_{CE} = 400\text{V}$   
 $I_{CE} = 6.0\text{A}$ ;  $V_{GE} = 15\text{V}$



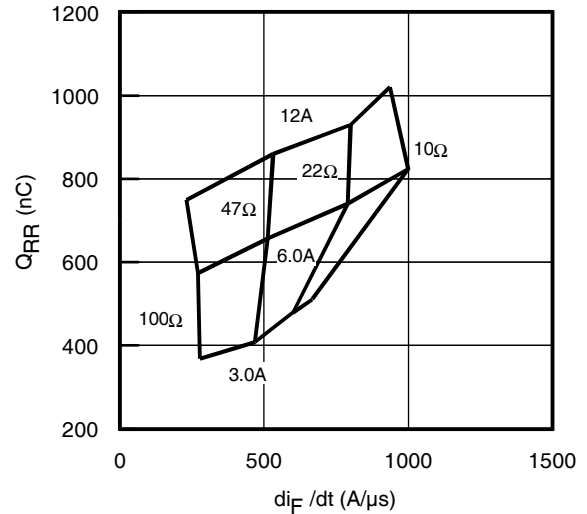
**Fig. 17** - Typical Diode  $I_{RR}$  vs.  $I_F$   
 $T_J = 175^\circ\text{C}$



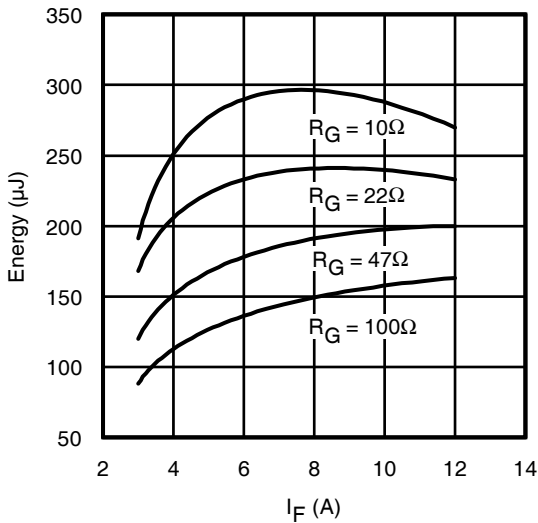
**Fig. 18** - Typical Diode  $I_{RR}$  vs.  $R_G$   
 $T_J = 175^\circ\text{C}$ ;  $I_F = 6.0\text{A}$



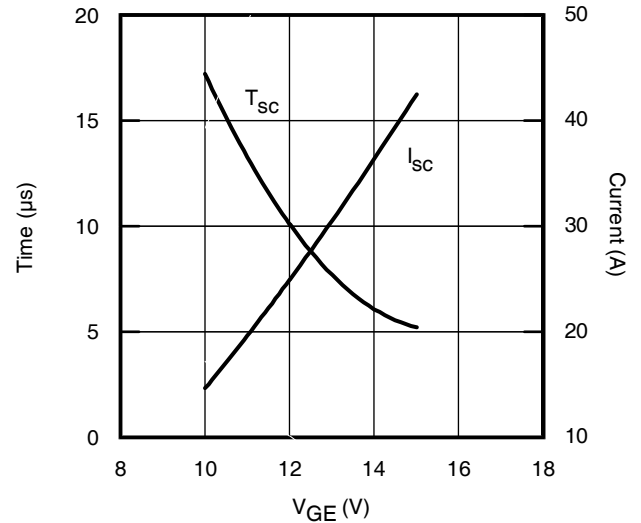
**Fig. 19**- Typical Diode  $I_{RR}$  vs.  $di_F/dt$   
 $V_{CC}= 400V$ ;  $V_{GE}= 15V$ ;  
 $I_{CE}= 6.0A$ ;  $T_J = 175^\circ C$



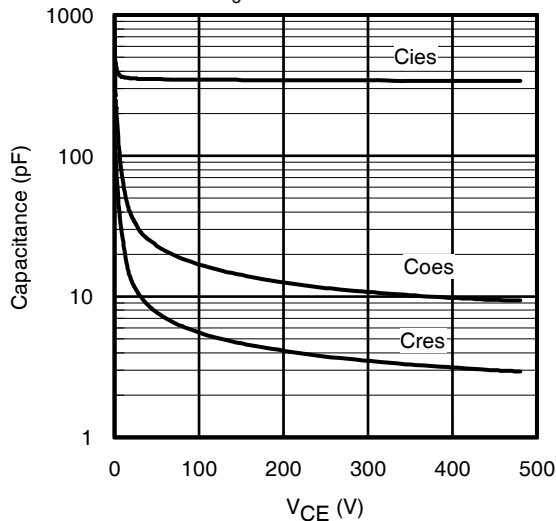
**Fig. 20** - Typical Diode  $Q_{RR}$   
 $V_{CC}= 400V$ ;  $V_{GE}= 15V$ ;  $T_J = 175^\circ C$



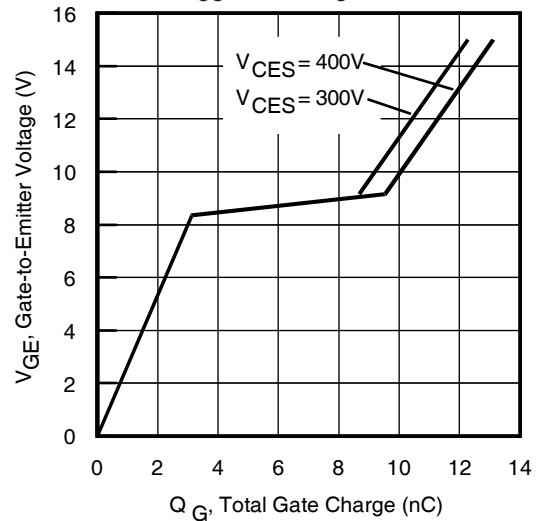
**Fig. 21** - Typical Diode  $E_{RR}$  vs.  $I_F$   
 $T_J = 175^\circ C$



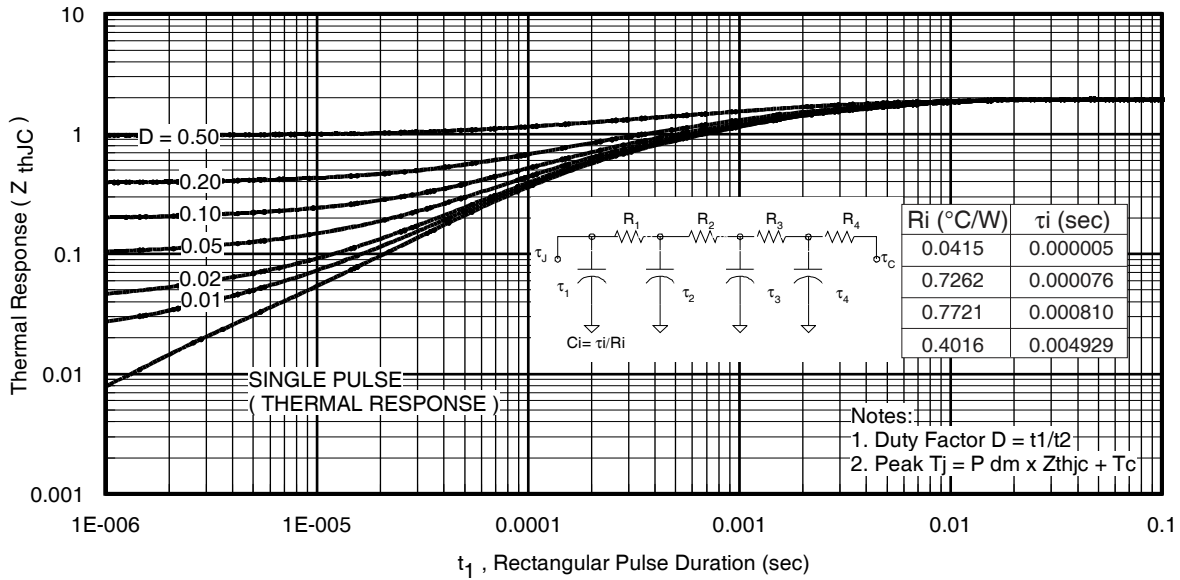
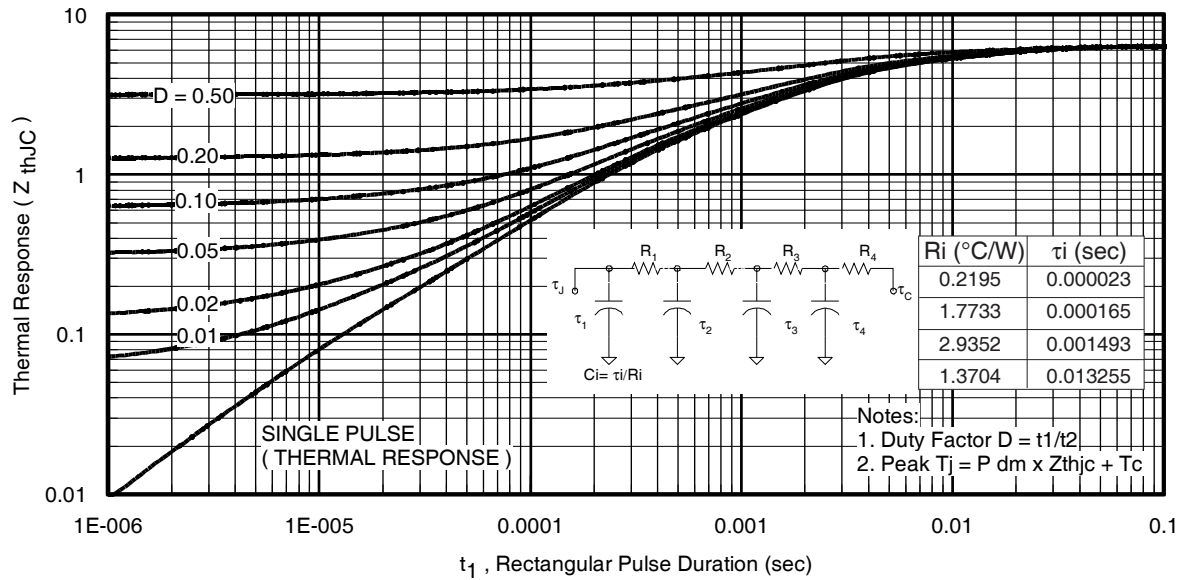
**Fig. 22**- Typ.  $V_{GE}$  vs. Short Circuit Time  
 $V_{CC}=400V$ ,  $T_C = 25^\circ C$



**Fig. 23**- Typ. Capacitance vs.  $V_{CE}$   
 $V_{GE}= 0V$ ;  $f = 1MHz$



**Fig. 24** - Typical Gate Charge vs.  $V_{GE}$   
 $I_{CE} = 6.0A$ ,  $L=600\mu H$


**Fig 25.** Maximum Transient Thermal Impedance, Junction-to-Case (IGBT)

**Fig. 26.** Maximum Transient Thermal Impedance, Junction-to-Case (DIODE)



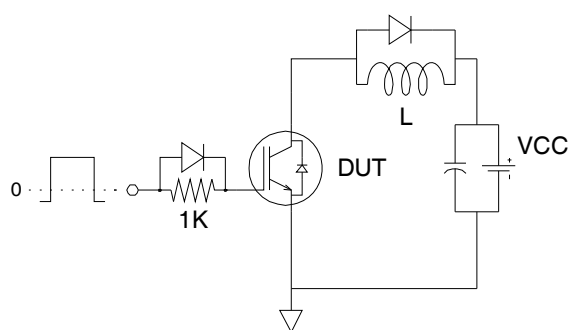


Fig.C.T.1 - Gate Charge Circuit (turn-off)

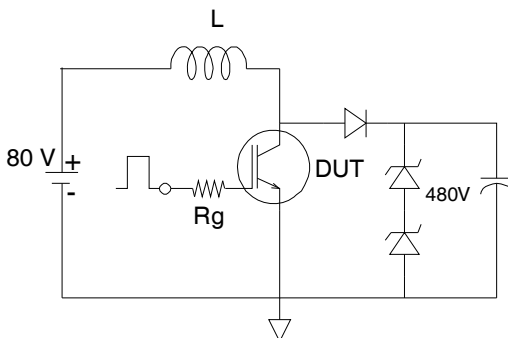


Fig.C.T.2 - RBSOA Circuit

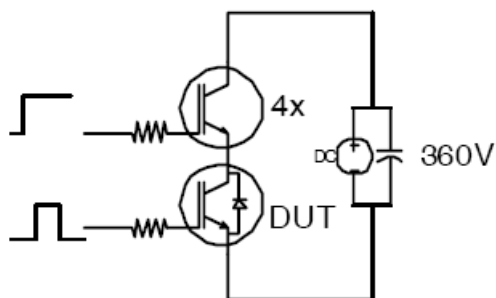


Fig.C.T.3 - S.C.SOA Circuit

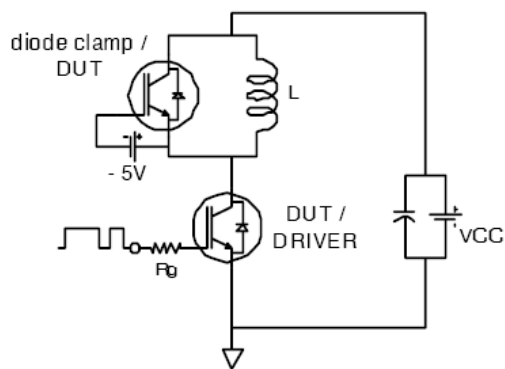


Fig.C.T.4 - Switching Loss Circuit

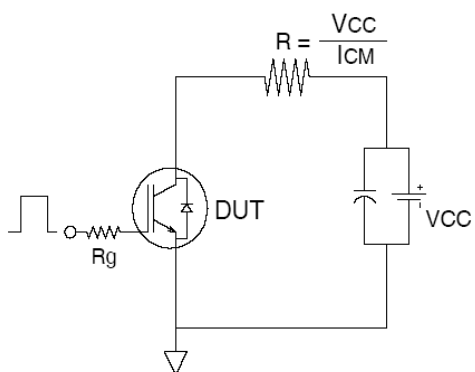
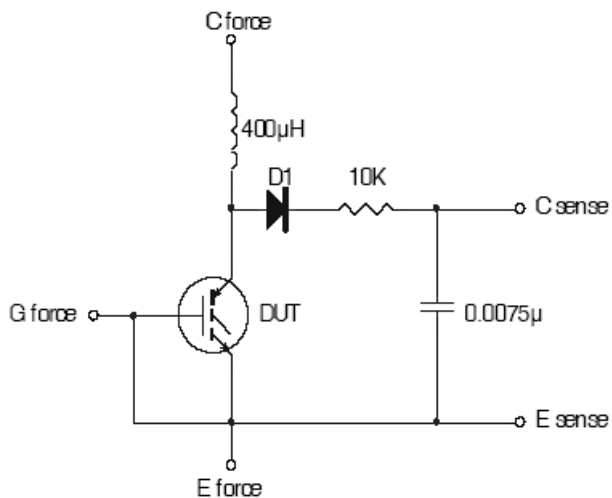
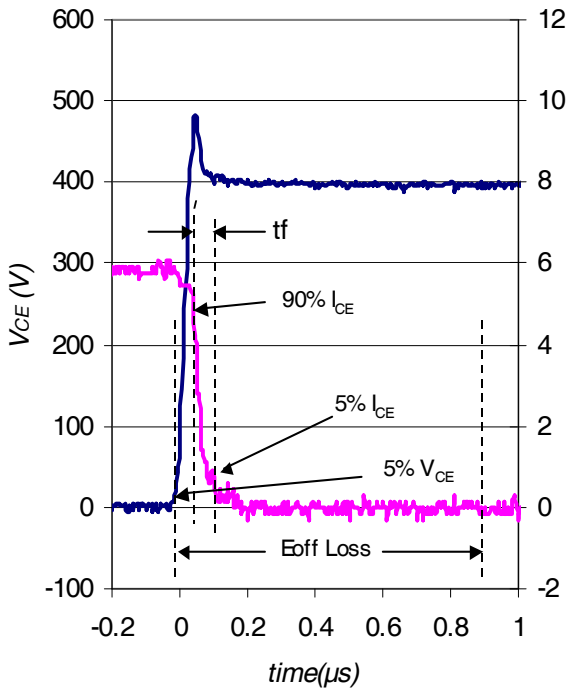
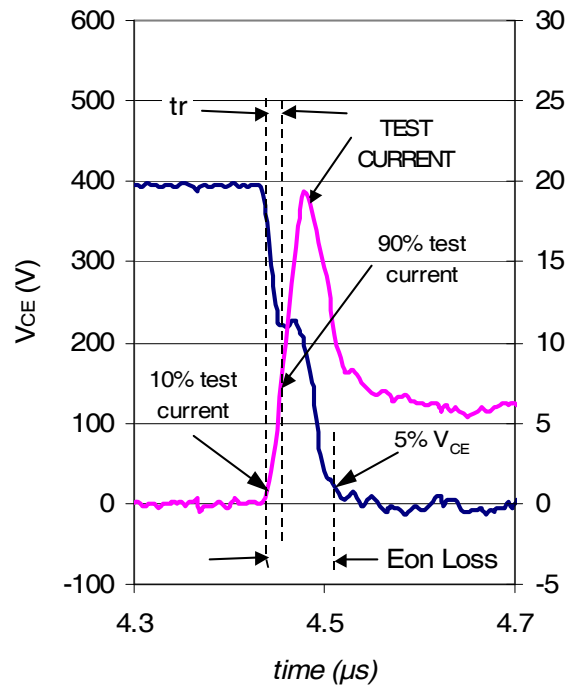


Fig.C.T.5 - Resistive Load Circuit

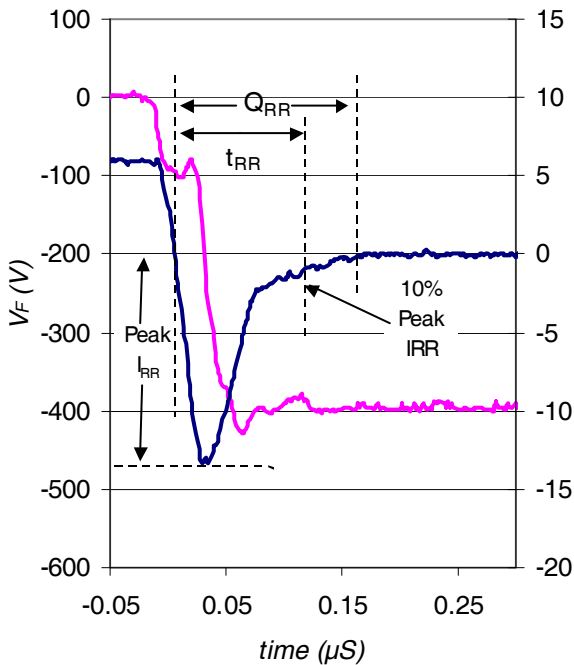

 Fig.C.T.6 - Typical Filter Circuit for  $V_{(BR)CES}$  Measurement



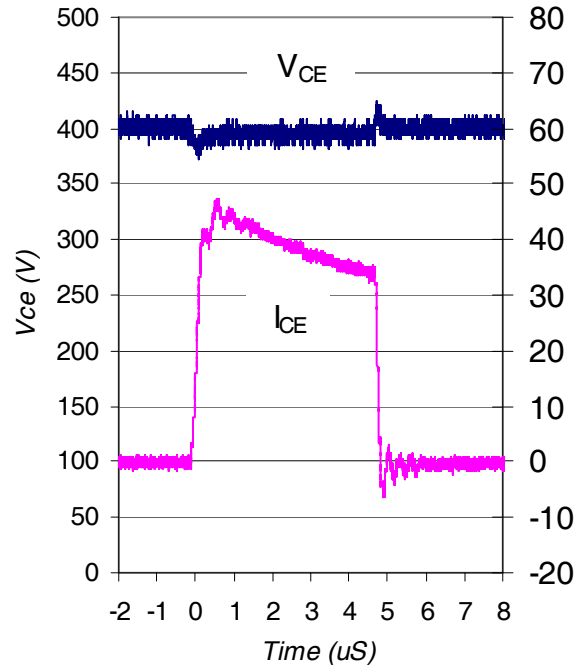
**Fig. WF1** - Typ. Turn-off Loss Waveform  
@  $T_J = 175^\circ\text{C}$  using Fig. CT.4



**Fig. WF2** - Typ. Turn-on Loss Waveform  
@  $T_J = 175^\circ\text{C}$  using Fig. CT.4



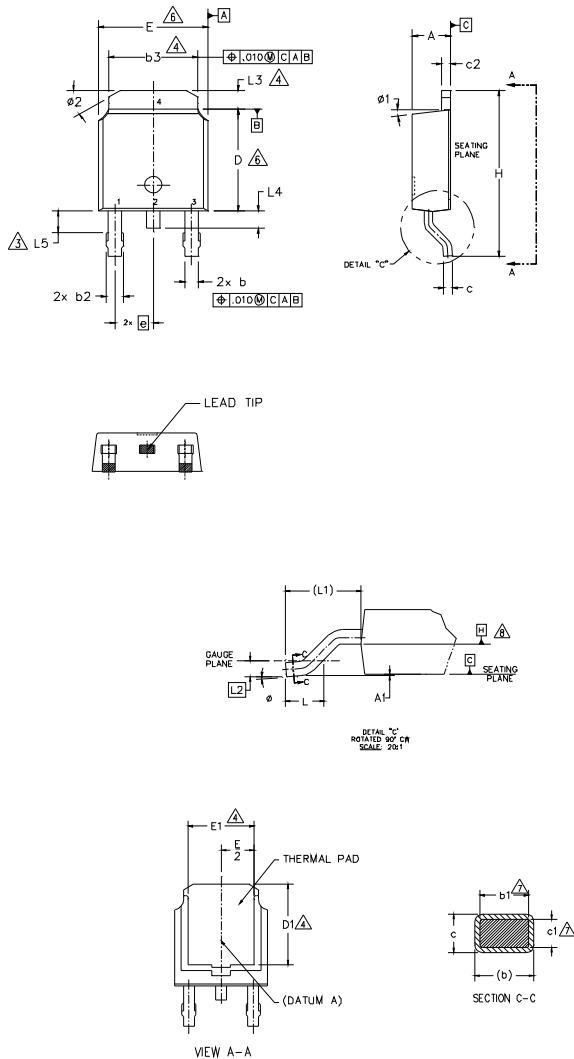
**WF.3-** Typ. Diode Recovery Waveform  
@  $T_J = 175^\circ\text{C}$  using CT.4



**WF.4-** Typ. Short Circuit Waveform  
@  $T_J = 25^\circ\text{C}$  using CT.3

## D-Pak (TO-252AA) Package Outline

Dimensions are shown in millimeters (inches)



**NOTES:**

- 1.- DIMENSIONING AND TOLERANCING PER ASME Y14.5M-1994
- 2.- DIMENSIONS ARE SHOWN IN INCHES [MILLIMETERS]
- 3.- LEAD DIMENSION UNCONTROLLED IN L5.
- 4.- DIMENSION D1, E1, L3 & b3 ESTABLISH A MINIMUM MOUNTING SURFACE FOR THERMAL PAD.
- 5.- SECTION C-C DIMENSIONS APPLY TO THE FLAT SECTION OF THE LEAD BETWEEN .005 AND 0.10 [0.13 AND 0.25] FROM THE LEAD TIP.
- 6.- DIMENSION D & E DO NOT INCLUDE MOLD FLASH. MOLD FLASH SHALL NOT EXCEED .005 [0.13] PER SIDE. THESE DIMENSIONS ARE MEASURED AT THE OUTMOST EXTREMES OF THE PLASTIC BODY.
- 7.- DIMENSION b1 & c1 APPLIED TO BASE METAL ONLY.
- 8.- DATUM A & B TO BE DETERMINED AT DATUM PLANE H.
- 9.- OUTLINE CONFORMS TO JEDEC OUTLINE TO-252AA.

SYMBOL	DIMENSIONS				NOTES
	MILLIMETERS		INCHES		
	MIN.	MAX.	MIN.	MAX.	
A	2.18	2.39	.086	.094	
A1	-	0.13	-	.005	
b	0.64	0.89	.025	.035	
b1	0.65	0.79	.025	.031	7
b2	0.76	1.14	.030	.045	
b3	4.95	5.46	.195	.215	4
c	0.46	0.61	.018	.024	
c1	0.41	0.56	.016	.022	7
c2	0.46	0.89	.018	.035	
D	5.97	6.22	.235	.245	6
D1	5.21	-	.205	-	4
E	6.35	6.73	.250	.265	6
E1	4.32	-	.170	-	4
e	2.29 BSC		.090 BSC		
H	9.40	10.41	.370	.410	
L	1.40	1.78	.055	.070	
L1	2.74 BSC		.108 REF.		
L2	0.51 BSC		.020 BSC		
L3	0.89	1.27	.035	.050	4
L4	-	1.02	-	.040	
L5	1.14	1.52	.045	.060	3
∅	0"	10"	0"	10"	
∅1	0"	15"	0"	15"	
∅2	25"	35"	25"	35"	

LEAD ASSIGNMENTS

HEXFET

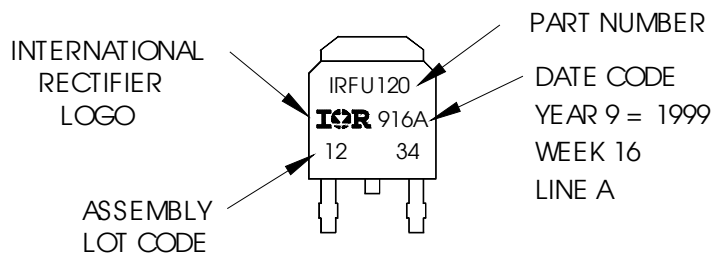
- 1.- GATE
- 2.- DRAIN
- 3.- SOURCE
- 4.- DRAIN

IGBT & CoPAK

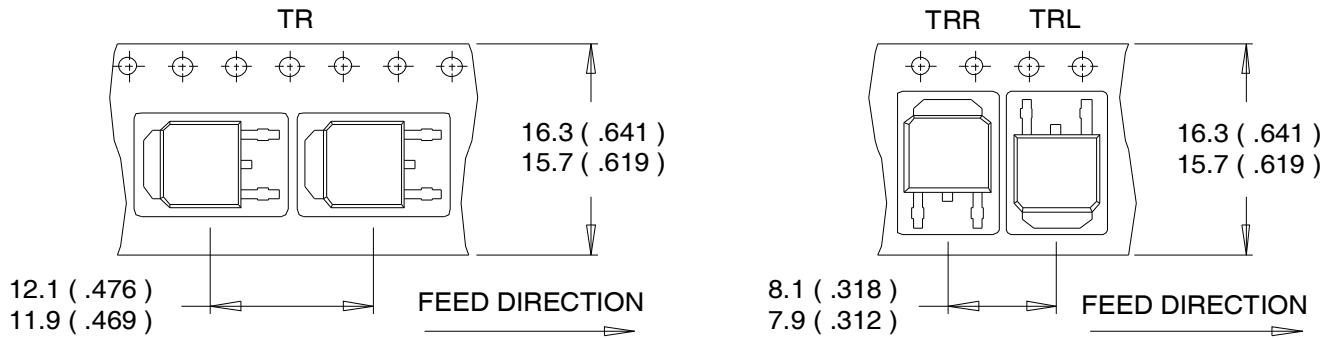
- 1.- GATE
- 2.- COLLECTOR
- 3.- EMITTER
- 4.- COLLECTOR

## D-Pak (TO-252AA) Part Marking Information

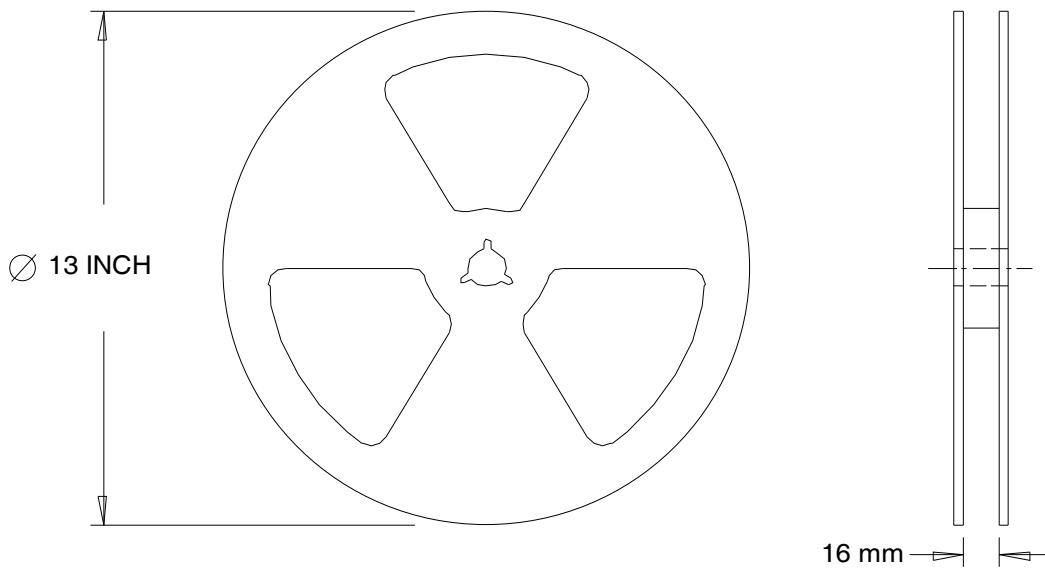
EXAMPLE: THIS IS AN IRFR120  
WITH ASSEMBLY  
LOT CODE 1234  
ASSEMBLED ON WW 16, 1999  
IN THE ASSEMBLY LINE "A"



Note: For the most current drawing please refer to IR website at <http://www.irf.com/package/>

**D-Pak (TO-252AA) Tape & Reel Information** (Dimensions are shown in millimeters (inches))

**NOTES :**

1. CONTROLLING DIMENSION : MILLIMETER.
2. ALL DIMENSIONS ARE SHOWN IN MILLIMETERS ( INCHES ).
3. OUTLINE CONFORMS TO EIA-481 & EIA-541.

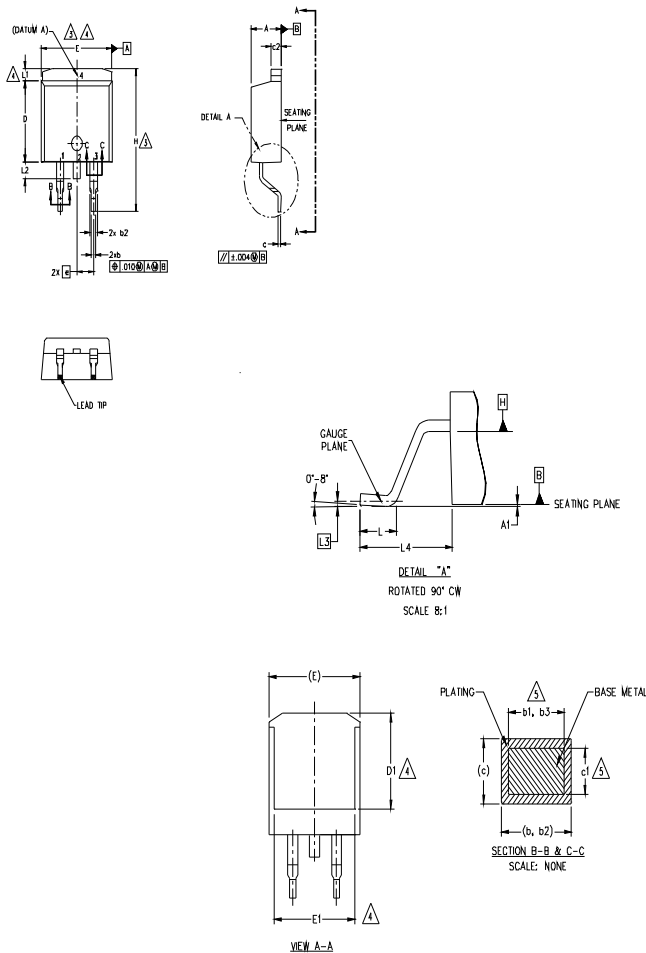

**NOTES :**

1. OUTLINE CONFORMS TO EIA-481.

Note: For the most current drawing please refer to IR website at <http://www.irf.com/package/>

## D<sup>2</sup>Pak Package Outline

Dimensions are shown in millimeters (inches)



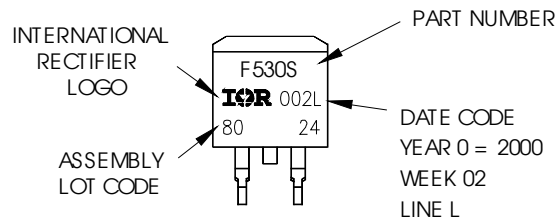
SYMBOL	DIMENSIONS				NOTES
	MILLIMETERS		INCHES		
	MIN.	MAX.	MIN.	MAX.	
A	4.06	4.83	.160	.190	5
A1	0.00	0.254	.000	.010	
b	0.51	0.99	.020	.039	
b1	0.51	0.89	.020	.035	
b2	1.14	1.78	.045	.070	
b3	1.14	1.73	.045	.068	
c	0.38	0.74	.015	.029	
c1	0.38	0.58	.015	.023	
c2	1.14	1.65	.045	.065	
D	8.38	9.65	.330	.380	
D1	6.86	—	.270	—	
E	9.65	10.67	.380	.420	
E1	6.22	—	.245	—	
e	2.54 BSC		.100 BSC		
H	14.61	15.88	.575	.625	
L	1.78	2.79	.070	.110	4
L1	—	1.65	—	.066	
L2	—	1.78	—	.070	
L3	0.25 BSC		.010 BSC		
L4	4.78	5.28	.188	.208	

- NOTES:
1. DIMENSIONING AND TOLERANCING PER ASME Y14.5M-1994
  2. DIMENSIONS ARE SHOWN IN MILLIMETERS [INCHES]
  3. DIMENSION D & E DO NOT INCLUDE MOLD FLASH. MOLD FLASH SHALL NOT EXCEED 0.127 [0.005"] PER SIDE. THESE DIMENSIONS ARE MEASURED AT THE OUTMOST EXTREMES OF THE PLASTIC BODY AT DATUM H.
  4. THERMAL PAD CONTOUR OPTIONAL WITHIN DIMENSION E, L1, D1 & E1.
  5. DIMENSION b1 AND c1 APPLY TO BASE METAL ONLY.
  6. DATUM A & B TO BE DETERMINED AT DATUM PLANE H.
  7. CONTROLLING DIMENSION: INCH.
  8. OUTLINE CONFORMS TO JEDEC OUTLINE TD-263AB

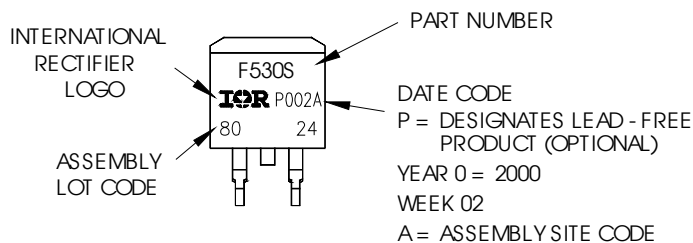
## D<sup>2</sup>Pak Part Marking Information

EXAMPLE: THIS IS AN IRF530S WITH LOT CODE 8024 ASSEMBLED ON WW02, 2000 IN THE ASSEMBLY LINE "L"

Note: "P" in assembly line position indicates "Lead - Free"

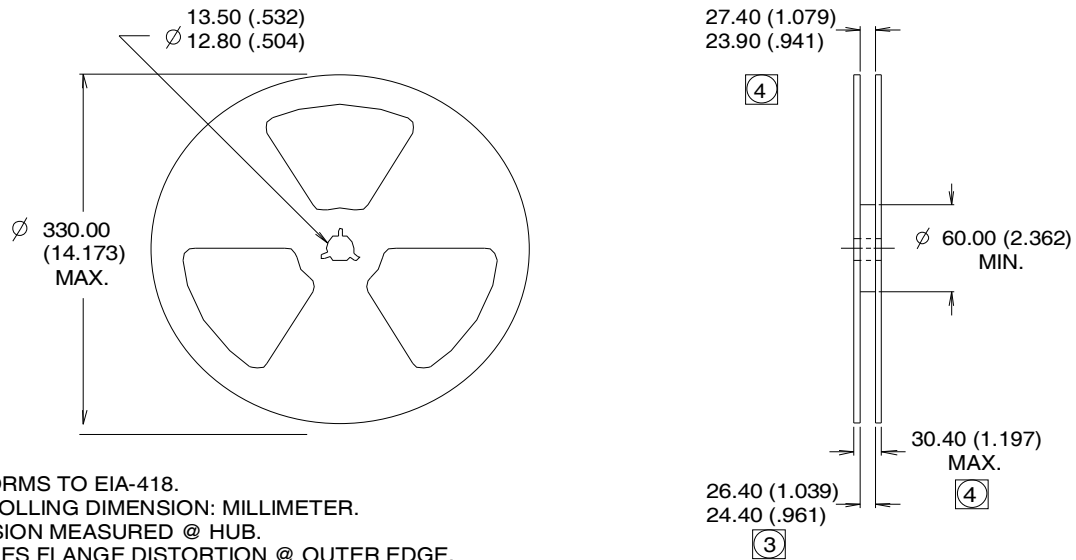
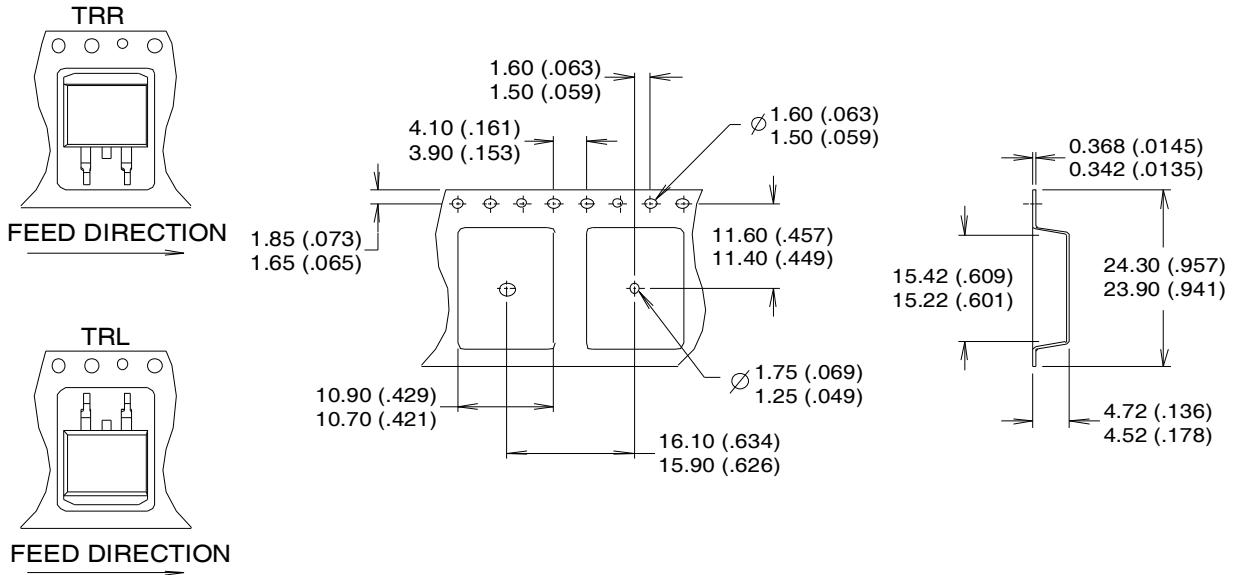


OR



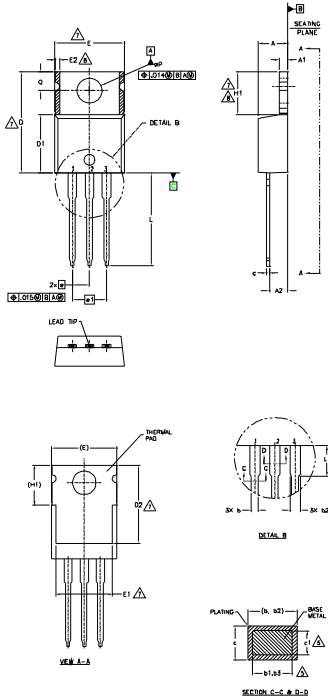
Note: For the most current drawing please refer to IR website at <http://www.irf.com/package/>

## D<sup>2</sup>Pak Tape & Reel Information (Dimensions are shown in millimeters (inches))



Note: For the most current drawing please refer to IR website at <http://www.irf.com/package/>

# TO-220AB Package Outline (Dimensions are shown in millimeters (inches))



- NOTES:
- 1.- DIMENSIONING AND TOLERANCING AS PER ASME Y14.5 M- 1994.
  - 2.- DIMENSIONS ARE SHOWN IN INCHES [MILLIMETERS].
  - 3.- LEAD DIMENSION AND FINISH UNCONTROLLED IN L1.
  - 4.- DIMENSION D, D1 & E DO NOT INCLUDE MOLD FLASH. MOLD FLASH SHALL NOT EXCEED .005" (0.127) PER SIDE. THESE DIMENSIONS ARE MEASURED AT THE OUTERMOST EXTREMES OF THE PLASTIC BODY.
  - 5.- DIMENSION b1, b3 & c1 APPLY TO BASE METAL ONLY.
  - 6.- CONTROLLING DIMENSION : INCHES.
  - 7.- THERMAL PAD CONTOUR OPTIONAL WITHIN DIMENSIONS E,H1,D2 & E1
  - 8.- DIMENSION E2 X H1 DEFINE A ZONE WHERE STAMPING AND SINGULATION IRREGULARITIES ARE ALLOWED.
  - 9.- OUTLINE CONFORMS TO JEDEC TO-220, EXCEPT A2 (max.) AND D2 (min.) WHERE DIMENSIONS ARE DERIVED FROM THE ACTUAL PACKAGE OUTLINE.

SYMBOL	DIMENSIONS				NOTES
	MILLIMETERS		INCHES		
	MIN.	MAX.	MIN.	MAX.	
A	3.56	4.83	.140	.190	
A1	1.14	1.40	.045	.055	
A2	2.03	2.92	.080	.115	
b	0.38	1.01	.015	.040	
b1	0.38	0.97	.015	.038	5
b2	1.14	1.78	.045	.070	
b3	1.14	1.73	.045	.068	5
c	0.36	0.61	.014	.024	
c1	0.36	0.56	.014	.022	5
D	14.22	16.51	.560	.650	4
D1	8.38	9.02	.330	.355	
D2	11.68	12.88	.460	.507	7
E	9.65	10.67	.380	.420	4,7
E1	6.86	8.89	.270	.350	7
E2	-	0.76	-	.030	8
e	2.54 BSC		.100 BSC		
e1	5.08 BSC		.200 BSC		
H1	5.84	6.86	.230	.270	7,8
L	12.70	14.73	.500	.580	
L1	3.56	4.06	.140	.160	3
ØP	3.54	4.08	.139	.161	
Q	2.54	3.42	.100	.135	

**LEAD ASSIGNMENTS**

- HEXCEL  
 1.- GATE  
 2.- DRAIN  
 3.- SOURCE

**GB15, G2PACK**

- 1.- GATE  
 2.- COLLECTOR  
 3.- EMITTER

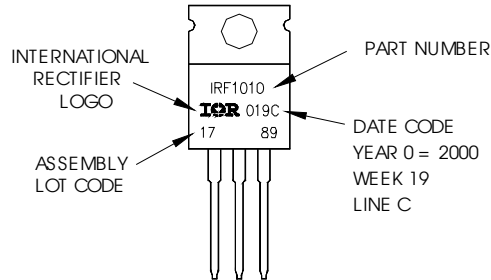
**DIODES**

- 1.- ANODE  
 2.- CATHODE  
 3.- ANODE

## TO-220AB Part Marking Information

EXAMPLE: THIS IS AN IRF1010  
 LOT CODE 1789  
 ASSEMBLED ON WW19, 2000  
 IN THE ASSEMBLY LINE "C"

Note: "P" in assembly line position indicates "Lead - Free"



TO-220AB packages are not recommended for Surface Mount Application.

Note: For the most current drawing please refer to IR website at <http://www.irf.com/package/>

**Qualification Information<sup>†</sup>**

<b>Qualification Level</b>	Industrial (per JEDEC JESD47F) <sup>††</sup>	
<b>Moisture Sensitivity Level</b>	D-Pak	MSL1
	D <sup>2</sup> Pak	
	TO-220	N/A
<b>RoHS Compliant</b>	Yes	

<sup>†</sup> Qualification standards can be found at International Rectifier's web site: <http://www.irf.com/product-info/reliability>

<sup>††</sup> Applicable version of JEDEC standard at the time of product release

**Revision History**

<b>Date</b>	<b>Comments</b>
11/14/2014	<ul style="list-style-type: none"> <li>• Added note ④ to I<sub>FM</sub> Diode Maximum Forward Current on page 1.</li> <li>• Removed note ④ to switching losses test condition on page 3.</li> <li>• Updated package outline on page 15.</li> </ul>