

1.24V Precision Adjustable Shunt Regulator

FEATURES

- Low Voltage Operation, 1.24V
- Trimmed Bandgap to 0.5% and 1%
- Wide Operating Current, 1mA to 80mA
- Adjustable Output Voltage, V_{REF} to 18V
- Extended Temp. Range: 0°C to 105°C
- Low Temperature Coefficient, 50 ppm/°C
- Offered in TO-92, SOIC, SOT-23-3
- Replacement for TLV431, AS432

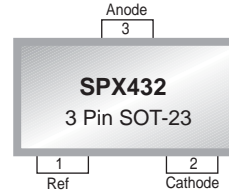

Now Available in Lead Free Packaging

Refer to page 11 for other pinouts.

APPLICATIONS

- Switching Power Supplies
- Adjustable Supplies
- Error Amplifiers
- Single Supply Amplifier
- Monitors / VCRs / TVs
- Personal Computers
- Voltage References

DESCRIPTION

The SPX432 is a 3-terminal adjustable shunt voltage regulator providing a highly accurate 1.24V bandgap reference with 0.5% tolerance. The SPX432's thermal stability, wide operating current (80mA) and temperature range (0°C to 105°C) makes it suitable for a variety of applications. SPX432 tolerance of 0.5% is proven to be sufficient to overcome all of the other errors in the system to virtually eliminate the need for trimming in the power supply manufacturers' assembly lines and contribute a significant cost savings.

The SPX432 is an ideal voltage reference in an isolated feedback circuit for switch mode power supplies. SPX432 offers many advantages over the TLV431 such as wider output voltage (18V vs. 6V), higher output current (80mA vs. 15mA) and a wider operating temperature range with a tighter tolerance down to 0.5%.

BLOCK DIAGRAM

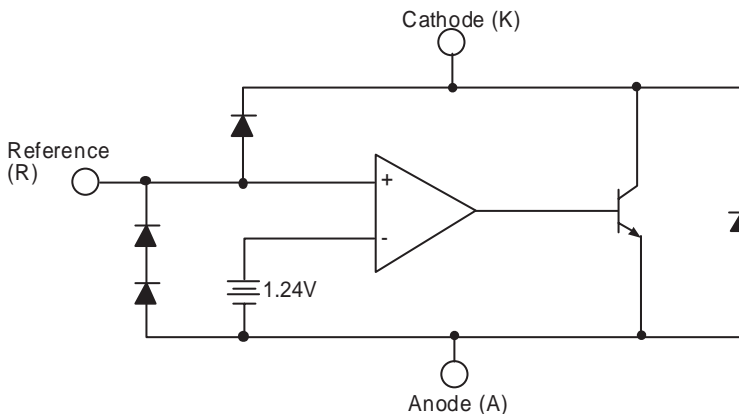

ABSOLUTE MAXIMUM RATINGS

Cathode-Anode Reverse Breakdown V_{KA}	20V
Anode-Cathode Forward Current, (<10ms) I_{AK}	1A
Operating Cathode Current I_{KA}	80mA
Reference Input Current I_{REF}	1mA

Continuous Power Dissipation at 25°C P_D

TO-92	775mW
SOT-23	200 mW
SOIC-8	750mW
Junction Temperature T_J	150 °C
Storage Temperature T_{STG}	-65°C to 150 °C
Lead Temperature (Soldering 10 sec.) T_L	300°C

Stresses greater than those listed under ABSOLUTE MAXIMUM RATINGS may cause permanent damage to the device. This is a stress rating only and functional operation of the device at these or any other conditions above those indicated in the operational sections of this specification is not implied. Exposure to absolute maximum rating conditions for extended periods may affect reliability.

RECOMMENDED CONDITIONS

PARAMETER	SYMBOL	RATING	UNIT
Cathode Voltage	V_{KA}	V_{REF} to 18	V
Cathode Current	I_K	10	mA

TYPICAL THERMAL RESISTANCES

PACKAGE	θ_{JA}	θ_{JC}	TYPICAL DERATING
TO-92	160°C/W	80°C/W	6.3mW/°C
SOT-23	575°C/W	150°C/W	1.7 mW/°C
SOIC-8	175°C/W	45°C/W	5.7mW/°C

Typical deratings of the thermal resistances are given for ambient temperature >25°C.

ELECTRICAL CHARACTERISTICS

Electrical characteristics are guaranteed over the full junction temperature range (0°C to 105°C). Ambient temperature must be derated based upon power dissipation and package thermal characteristics. Unless otherwise specified, test conditions are:

$$V_{KA} = V_{REF} \text{ and } I_K = 10\text{mA.}$$

PARAMETER	SYMBOL	TEST CIRCUIT	CONDITIONS	MIN	TYP	MAX	MIN	TYP	MAX	UNITS
				SPX432A			SPX432			
Output Voltage	V_{REF}	3a		1.2338	1.240	1.2462	1.2276	1.240	1.2524	V
Temperature Deviation	V_{REF}	3a	$0 < T_J < 105^\circ\text{C}$		12	20		12	20	mV
Line Regulation	V_{REF}	3b	$V_{KA} = 1.25\text{V to }15\text{V}$		19	37		19	37	mV
Load Regulation	V_{REF}	3a	$I_K = 1\text{mA to }80\text{mA}$		12	30		12	30	mV
Reference Input Current	I_{REF}	3b			3	6		3	6	μA
Reference Input Current Temperature Coefficient	I_{REF}	3b	$0 < T_J < 105^\circ\text{C}$,		0.3	0.6		0.3	0.6	μA
Minimum Cathode Current for Regulation	$I_{K(MIN)}$	3a			0.6	1		0.6	1	mA
Off State Leakage	$I_{K(MIN)}$	3c	$V_{REF} = 0\text{V}$, $V_{KA} = 18\text{V}$		0.04	500		0.04	500	nA

CALCULATION AVERAGE TEMPERATURE COEFFICIENT (TC)

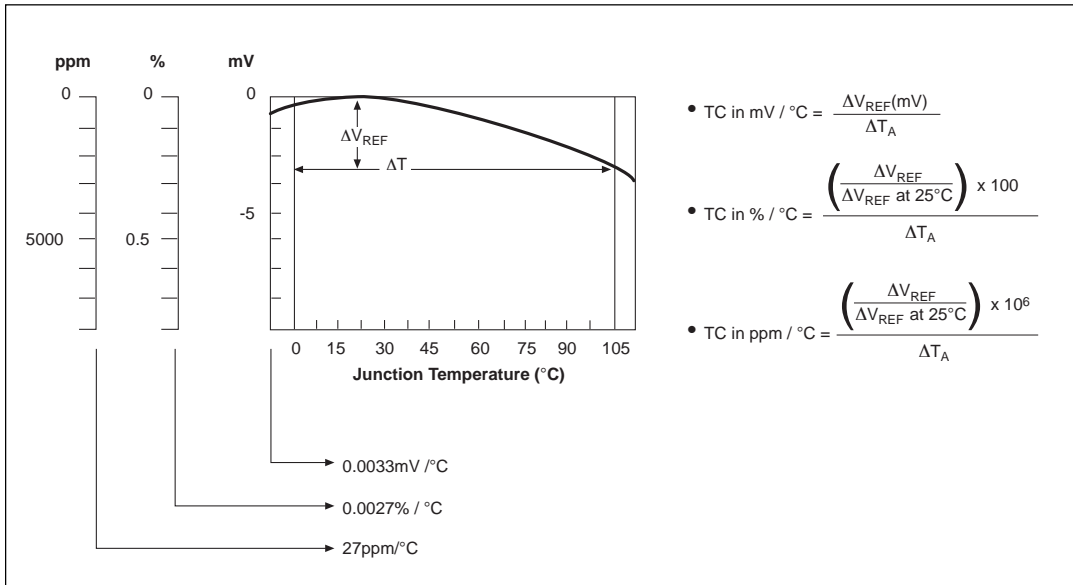

Figure 1. V_{REF} VS Temperature.

TEST CIRCUITS

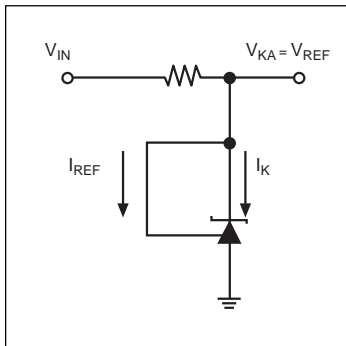

Figure 2. Test Circuit for $V_{KA} = V_{REF}$

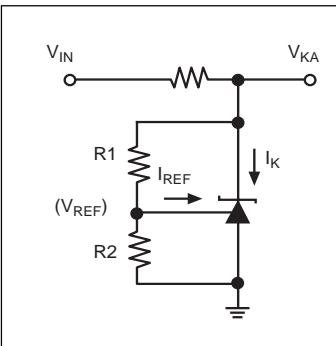

Figure 3. Test Circuit for $V_{KA} > V_{REF}$

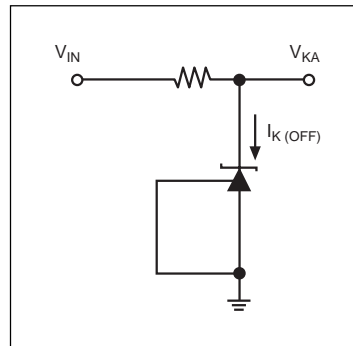
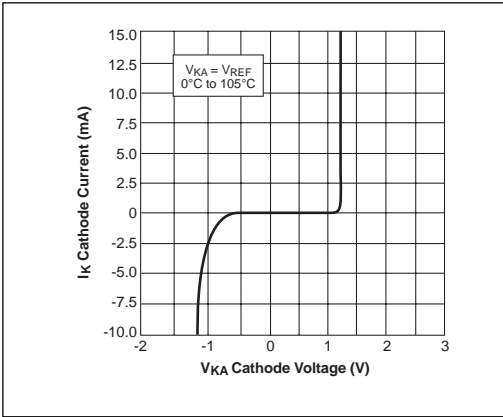
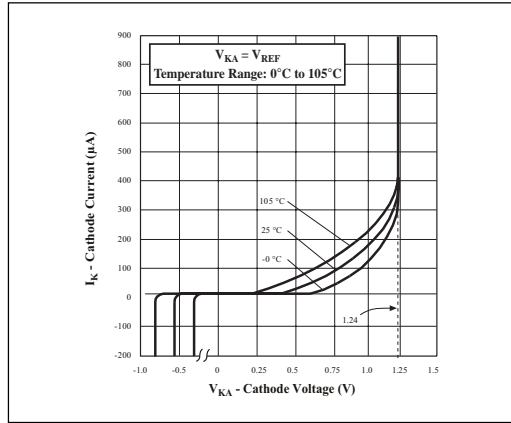

Figure 4. Test Circuit for $I_{K(OFF)}$

TYPICAL PERFORMANCE CHARACTERISTICS



High Current Operating Characteristics.



Low Current Operating Characteristics.

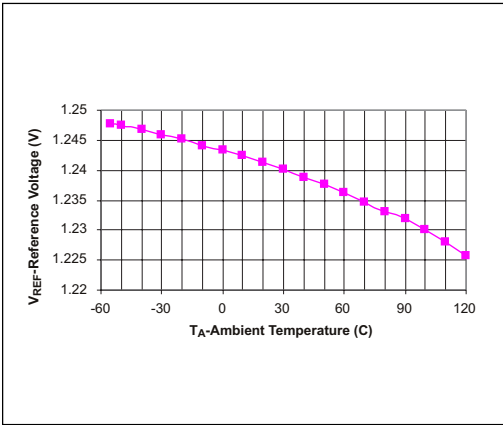

$V_{KA} = V_{REF}, I_{KA} = 10mA.$

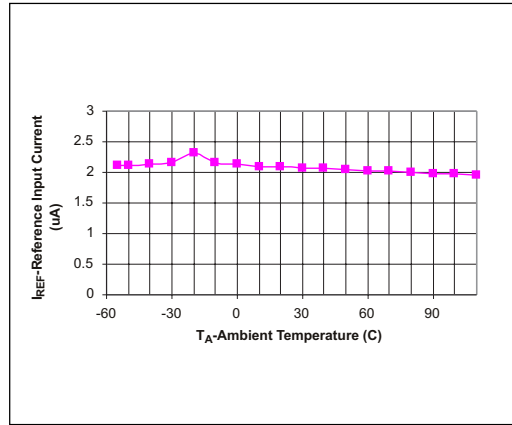

Reference Input Current VS Temperature; $I_{KA} = 10mA.$

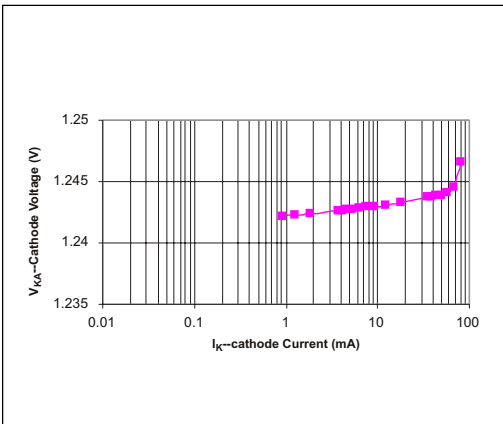

$V_{KA} = V_{REF},$ Sweeping $I_{KA}, 25^{\circ}C.$

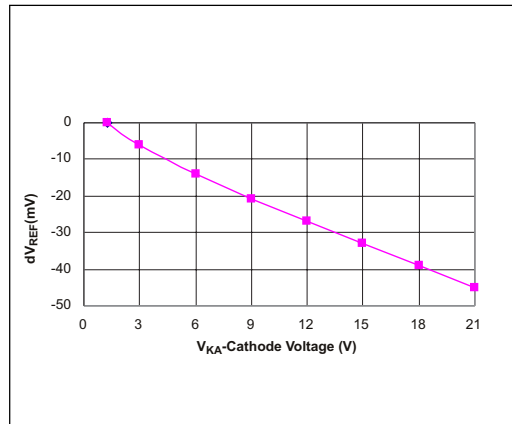

Reference Voltage Line Regulation; $I_{KA} = 10mA,$ Sweeping $V_{KA}, 25^{\circ}C.$

TYPICAL PERFORMANCE CHARACTERISTICS

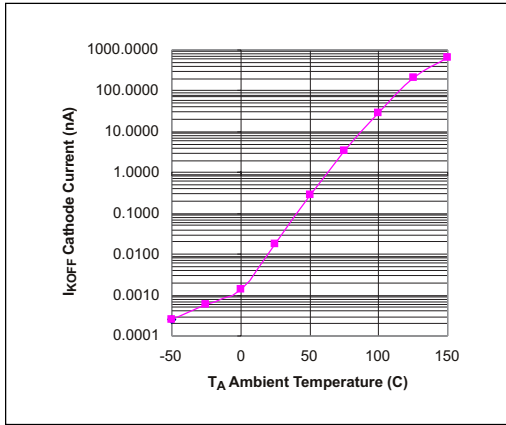

Off State Leakage; $V_{KA} = 18V$, $V_{REF} = 0V$.

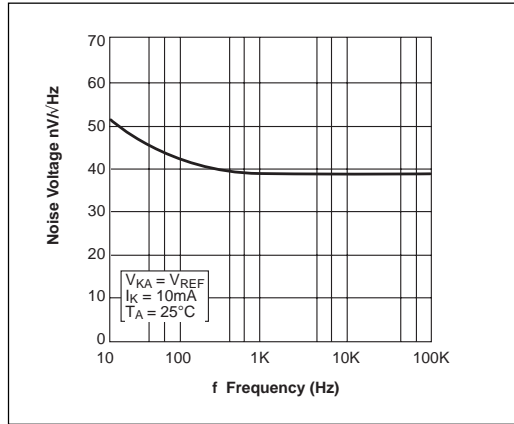

Noise Voltage VS Frequency.

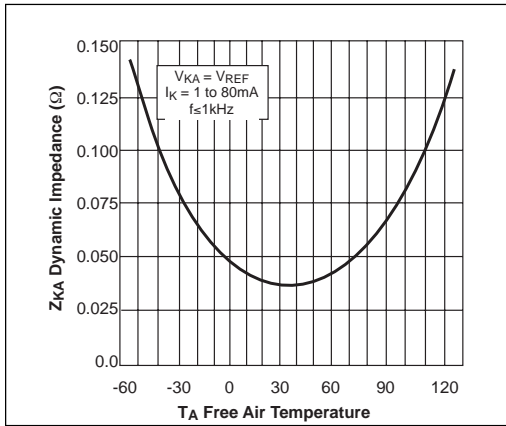

Low Frequency Dynamic Output Impedance VS $T_{AMBIENT}$

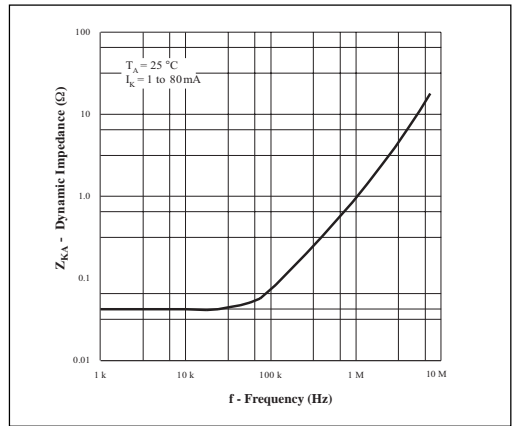

Dynamic Output Impedance $T_A = 25^\circ C$, $I_{KA} = 1$ to 80mA.

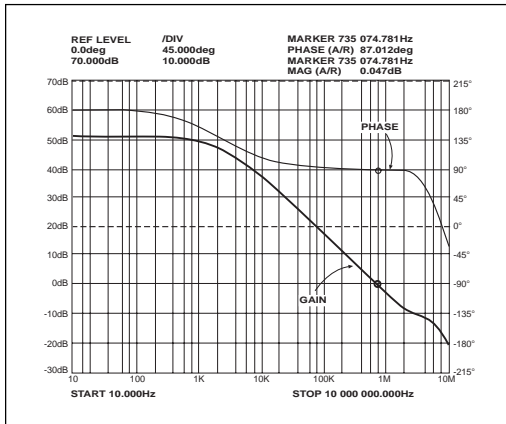

Small Signal Gain and Phase VS Frequency; $I_K = 10mA$, $T_A = 25^\circ C$.

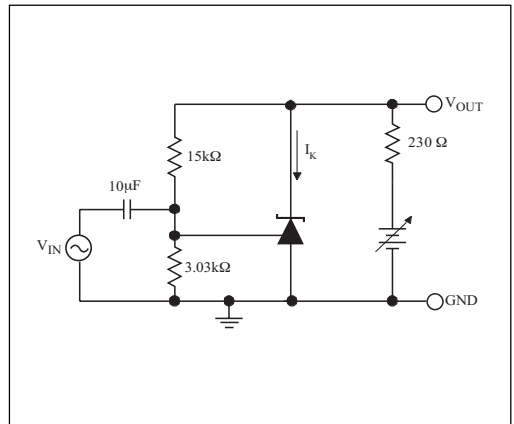

Test Circuit for Gain and Phase Frequency Response.

TYPICAL PERFORMANCE CHARACTERISTICS

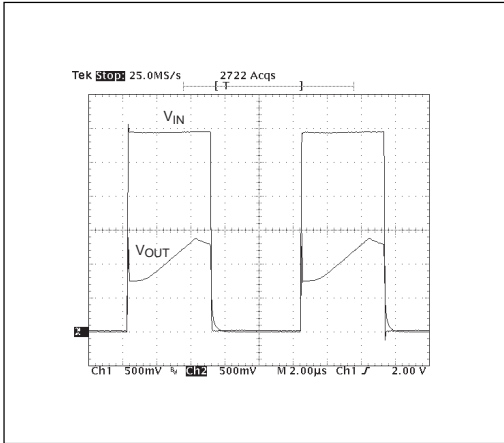

$I_{KA} = 0 \text{ to } 1\text{mA}$.

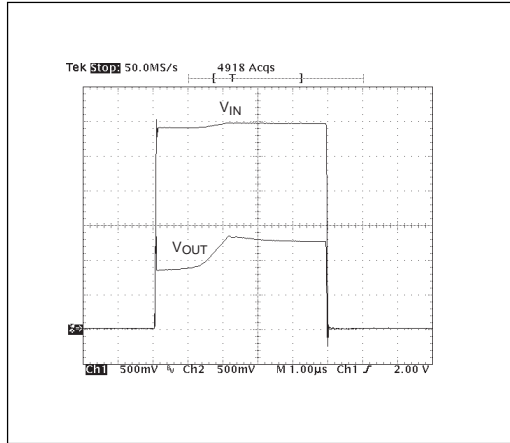

$I_{KA} = 0 \text{ to } 10\text{mA}$.

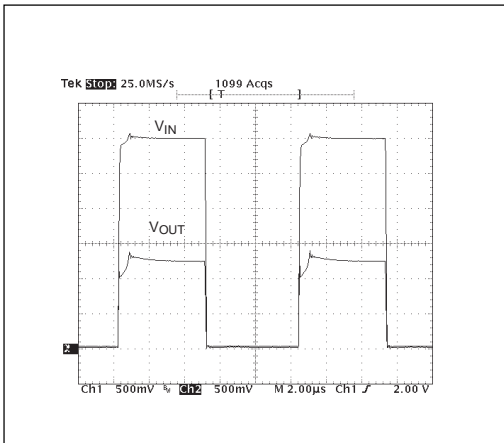

$I_{KA} = 0 \text{ to } 50\text{mA}$.

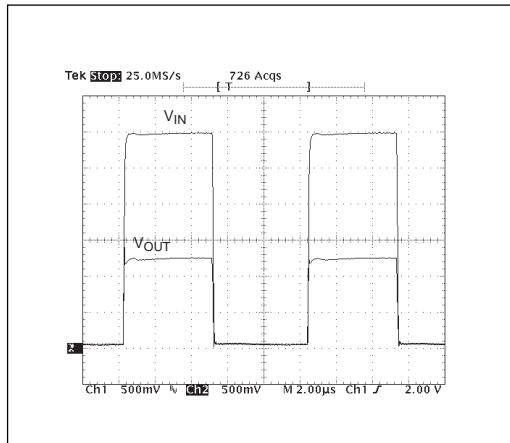

$I_{KA} = 0 \text{ to } 80\text{mA}$.

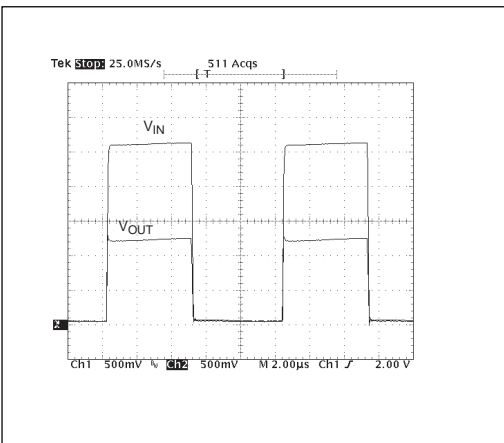

$I_{KA} = 0 \text{ to } 100\text{mA}$.

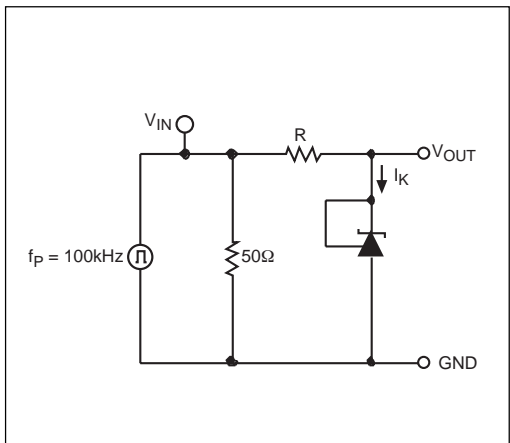

Test Circuit for Pulse Response.

TYPICAL PERFORMANCE CHARACTERISTICS

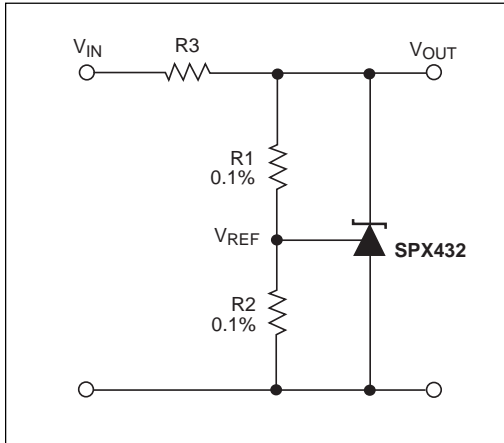

Shunt Regulator, $V_{OUT} = (1+R1/R2)V_{REF}$.

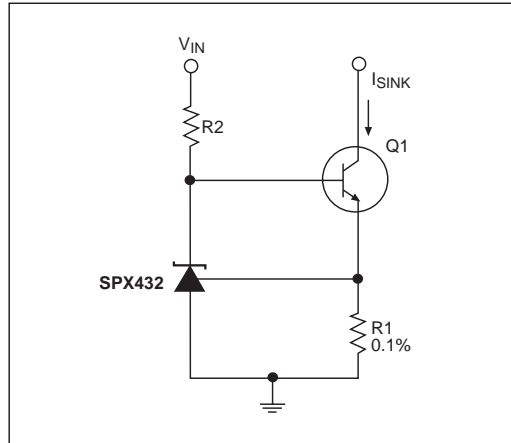

Constant Current Sink $I_{SINK} = V_{REF}/R1$.

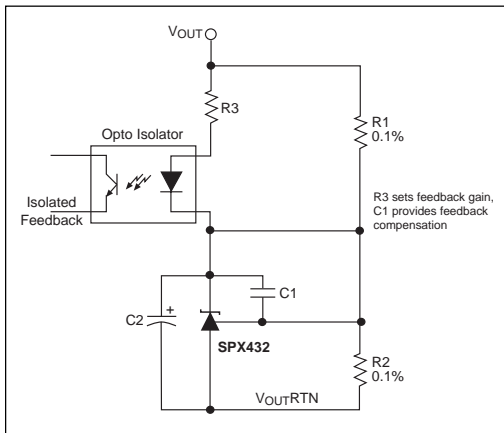

Reference Amplifier for Isolated Feedback in Off-Line DC-DC Converters.

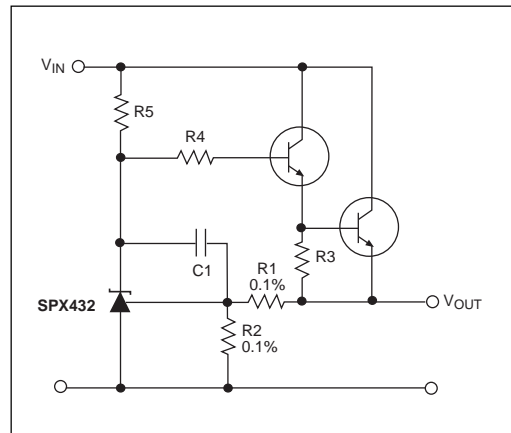

Precision High Current Series Regulator, $V_{OUT} = (1+R1/R2)V_{REF}$.

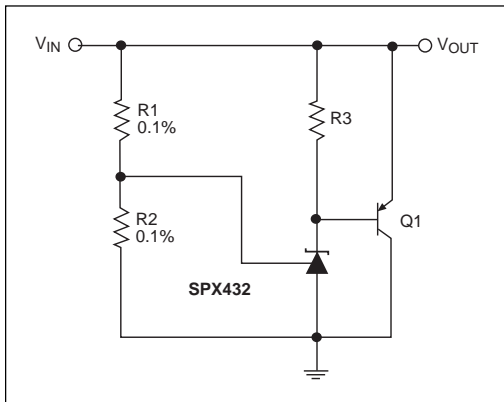

High Current Shunt Regulator, $V_{OUT} = (1+R1/R2)V_{REF}$.

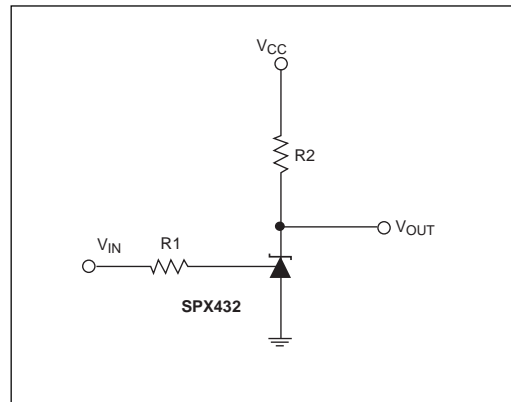

Single Supply Comparator with Temperature Compensated Threshold, V_{IN} threshold = 1.24V.

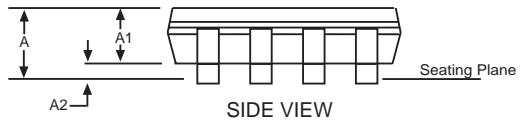
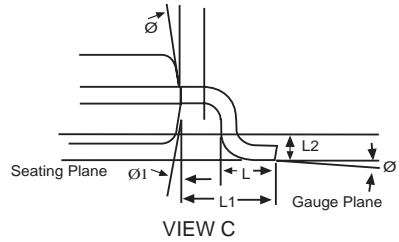
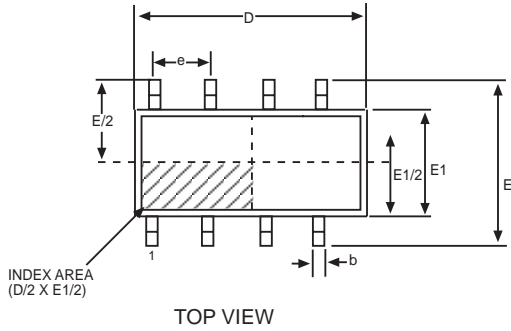

8 Pin NSOIC JEDEC MO-012 (AA) Variation			
SYMBOL	MIN	NOM	MAX
A	1.35	-	1.75
A1	0.1	-	0.25
A2	1.25	-	1.65
b	0.31	-	0.51
c	0.17	-	0.24
D	4.90 BSC		
E	6.00 BSC		
E1	3.90 BSC		
e	1.27 BSC		
L	0.4	-	1.27
L1	1.04 REF		
L2	0.25 BSC		
∅	0°	-	8°
∅1	5°	-	15°

Note: Dimensions in (mm)

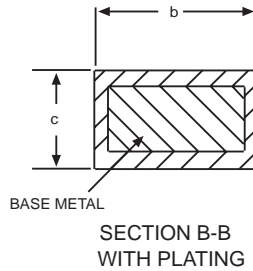
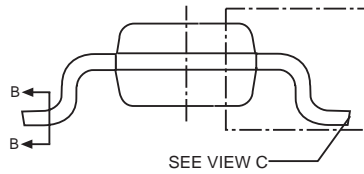

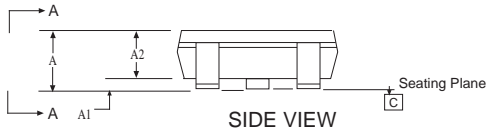
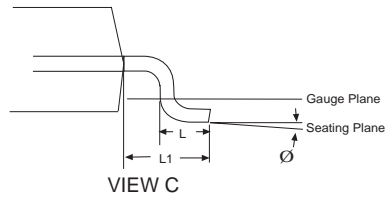
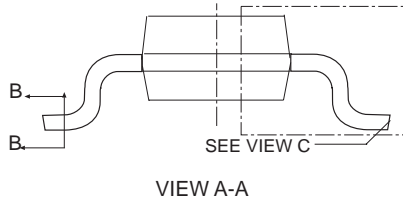
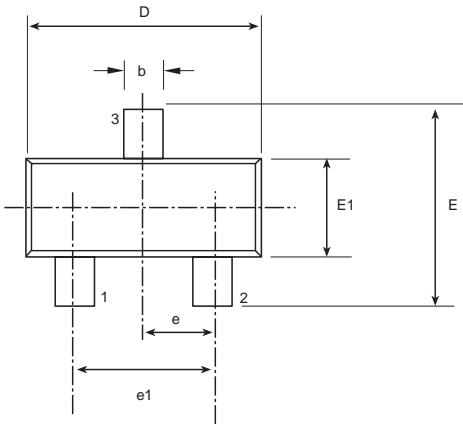

3 Pin SOT-23 JEDEC TO-236 (AB) Variation			
SYMBOL	MIN	NOM	MAX
A	0.89	-	1.12
A1	0.01	-	0.1
A2	0.88	0.95	1.02
b	0.3	-	0.5
c	0.08	-	0.2
D	2.8	2.9	3.04
e	0.95 BSC		
e1	1.90 BSC		
E	0.95	-	2.64
E1	1.2	1.3	1.4
L	0.4	0.5	0.6
L1	0.54 REF		
Ø	0°	-	8°

Note: Dimensions in (mm)

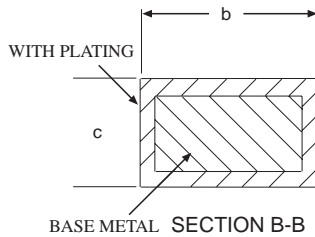

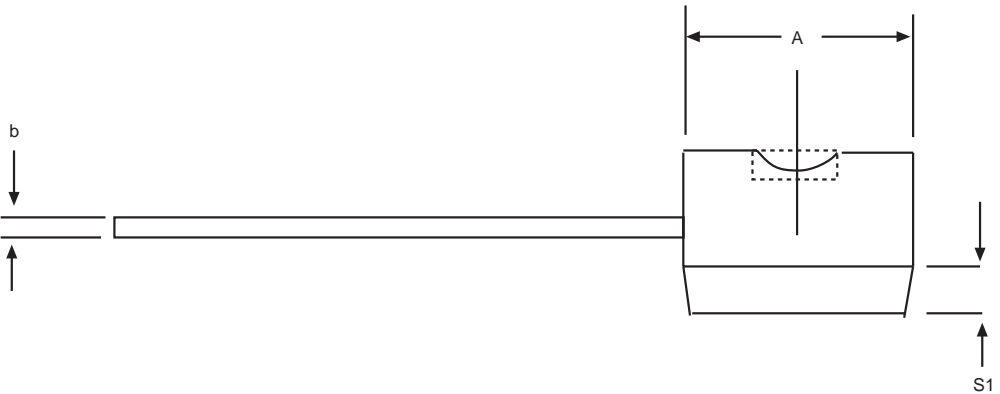
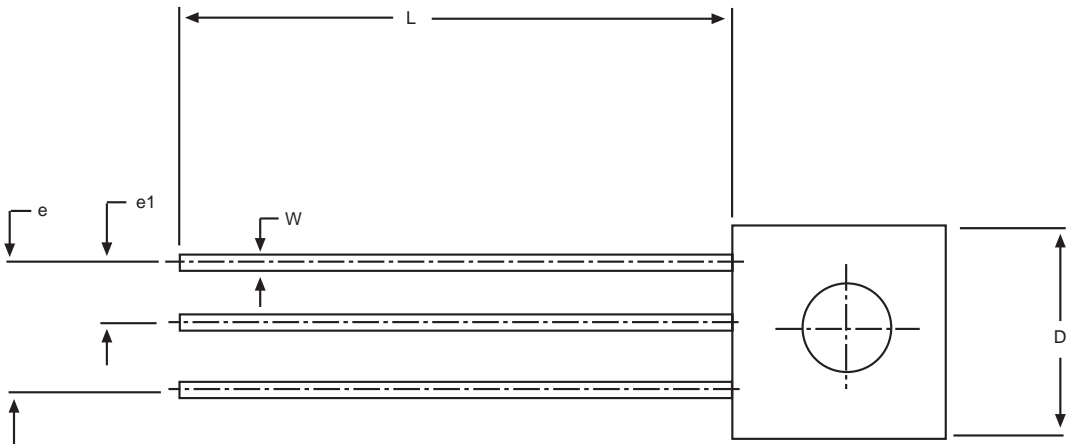

3 Pin TO-92			
SYMBOL	MIN	NOM	MAX
A	0.17	-	0.195
b	0.014	-	0.02
E	0.13	-	0.155
e	0.95	-	0.105
e1	0.045	-	0.055
L	0.5	-	0.61
R	0.085	-	0.095
S1	0.045	-	0.06
W	0.016	-	0.022
D	0.175	-	0.195
a	4°	-	6°

Note: Dimensions in (inches)

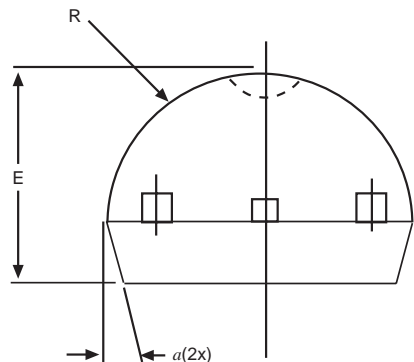

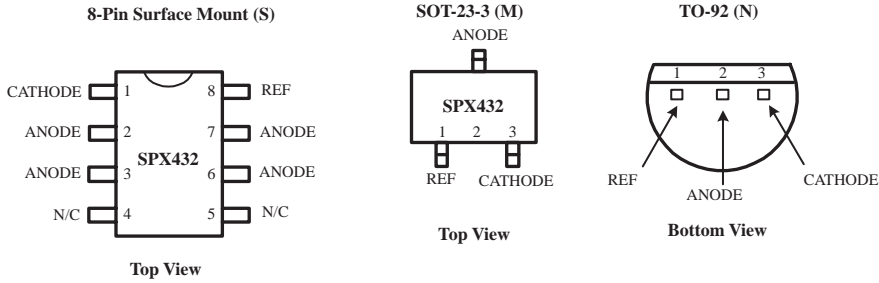

ORDERING INFORMATION

PART NUMBER	ACC	OUTPUT VOLTAGE	PACKAGES
SPX432AM	0.5%	1.24V	3-Pin SOT-23
SPX432AM/TR	0.5%	1.24V	3-Pin SOT-23
SPX432AS	0.5%	1.24V	8-Pin NSOIC
SPX432AS/TR	0.5%	1.24V	8-Pin NSOIC
SPX432AN	0.5%	1.24V	3-Pin TO-92
SPX432AN/TR	0.5%	1.24V	3-Pin TO-92
SPX432M	1.0%	1.24V	3-Pin SOT-23
SPX432M/TR	1.0%	1.24V	3-Pin SOT-23
SPX432S	1.0%	1.24V	8-Pin NSOIC
SPX432S/TR	1.0%	1.24V	8-Pin NSOIC
SPX432N	1.0%	1.24V	3-Pin TO-92
SPX432N/TR	1.0%	1.24V	3-Pin TO-92

Available in lead free packaging. To order add "-L" suffix to part number.

Example: SPX432AM/TR = standard; SPX432AM-L/TR = lead free

/TR = Tape and Reel

Pack quantity is 2,000 for TO-92 and 2500 for SOT-23 and NSOIC.

[CLICK HERE TO ORDER SAMPLES](#)



ANALOG EXCELLENCE

Sipex Corporation

Headquarters and Sales Office
 233 South Hillview Drive
 Milpitas, CA 95035
 TEL: (408) 934-7500
 FAX: (408) 935-7600

Sipex Corporation reserves the right to make changes to any products described herein. Sipex does not assume any liability arising out of the application or use of any product or circuit described herein; neither does it convey any license under its patent rights nor the rights of others.