

THIS DRAWING IS UNPUBLISHED. RELEASED FOR PUBLICATION
 © COPYRIGHT BY TYCO ELECTRONICS CORPORATION. ALL RIGHTS RESERVED.

| LOC | DIST | REVISIONS | | | |
|-----|------|-------------|--------------------------|-----------|--------|
| P | LTR | DESCRIPTION | DATE | DWN | APVD |
| AJ | 16 | A | REVISED PER OS14-0150-05 | 11NOV2005 | REH JL |

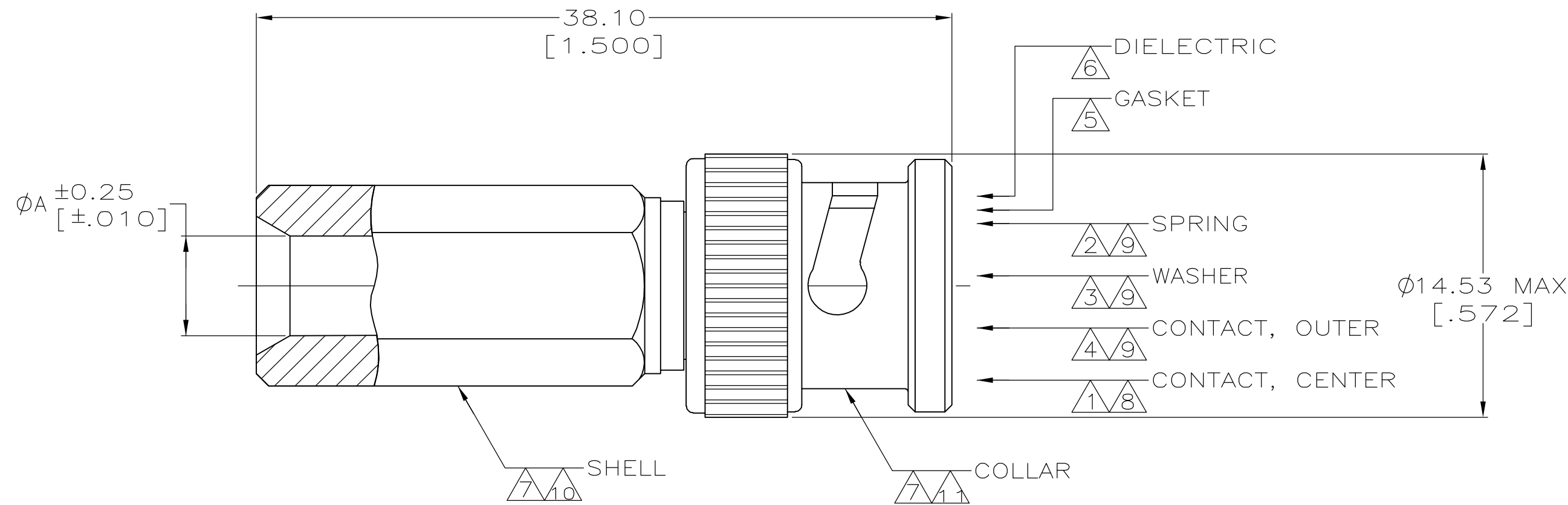

- 1 PHOSPHOR BRONZE PER ASTM-B-139
- 2 CARBON STEEL
- 3 BRASS PER MIL-C-50
- 4 BRASS PER QQ-B-626
- 5 SILICONE RUBBER PER ZZ-R-765
- 6 POLYMETHYLPENTENE: GENERAL PURPOSE
- 7 ZINC DIE CAST PER QQ-Z-363
- 8 GOLD PLATING PER ASTM-B-488
0.38 μ m [.000015] MIN THICKNESS
- 9 NICKEL PLATING PER QQ-N-290
2.54 μ m [.000100] MIN THICKNESS
- 10 NICKEL PLATING PER QQ-N-290
3.81 μ m [.000150] MIN THICKNESS
- 11 NICKEL PLATING PER QQ-N-290
4.45 μ m [.000175] MIN THICKNESS
- 12. USE INSTRUCTION SHEET 408-6996

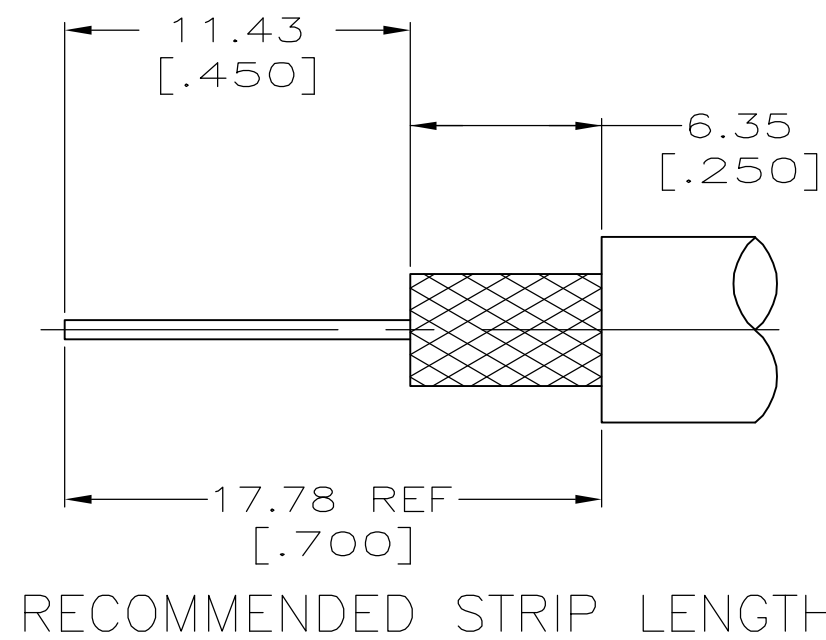

| | | |
|---------|-------------|-------------|
| RG-59/U | 5.49 [.216] | 5414265-3 |
| CABLE | A | PART NUMBER |

| | | | | |
|--|--|---------------------------|---|----------------------|
| THIS DRAWING IS A CONTROLLED DOCUMENT. | | DWN J. HAVENER 02NOV2005 | Tyco Electronics Corporation Harrisburg, PA 17105-3608 | |
| DIMENSIONS: mm [INCHES] | | CHK J. HAVENER 02NOV2005 | | |
| TOLERANCES UNLESS OTHERWISE SPECIFIED: | | APVD J. LIPPERT 02NOV2005 | NAME PLUG ASSEMBLY, 50 OHM, TWIST-ON, BNC | |
| 0 PLC ± - | | PRODUCT SPEC | SIZE A2 | |
| 1 PLC ± - | | APPLICATION SPEC | CAGE CODE 00779 | DRAWING NO C=5414265 |
| 2 PLC ± 0.51 [.020] | | WEIGHT - | RESTRICTED TO - | |
| 3 PLC ± - | | CUSTOMER DRAWING | SCALE 4:1 | SHEET 1 of 1 |
| 4 PLC ± - | | | REV A | |
| ANGLES ± - | | | | |
| FINISH SEE NOTES | | | | |