

LDC		DIST		REVISIONS			
P	LTR	DESCRIPTION		DATE	DWN	APVD	
	B	ECR-16-001943		09FEB2016	GH	GS	

# HTV10 HAND TOOL,

## 2,5 mm DIA. CONTACTS 0.5-1.0 SQ.MM

**FRONT VIEW**

**SIDE VIEW**

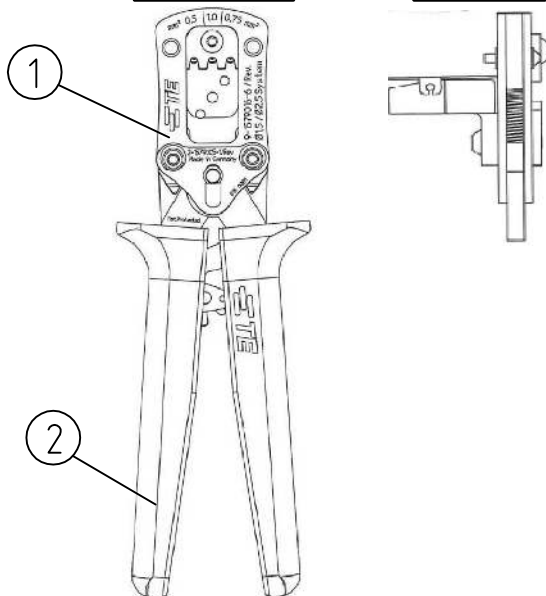

**Eigenschaften / Features**

Die Handzange verfügt über eine verschiebbare Crimpmatrize mit insgesamt zwei Crimpnestern in denen die Leitungsquerschnitte 0.5 und 0.75 mm<sup>2</sup> verarbeitet werden können. Die Kontakte werden mittels Klapppositionierer in der richtigen Ausgangsposition gehalten.

Hand tool with slideable crimping die set on which two crimping nests cover the wire sizes 0.5 and 0.75 mm<sup>2</sup>. Featured with a flap contact locator to allow correct positioning of the applied terminals.

**Abmessungen / Dimensions:**

Länge / Length: 226 mm  
 Breite / Width: 70 mm  
 Tiefe/Depth : 38 mm

**Ersatzteile/ Spare part:**

HTV10 CRIMP HEAD 2.5 DIA. CONTACTS 0.5-1.0  
 TE PN 9-1579016-6

**Anwendungsbereich /  
 Application range**

Leiterquerschnitt Cross section range	Leitercrimpöhe Conductor Crimp Height ± 0,05	Leitercrimpbreite Conductor Crimp Width gemessen an den Tangenten der Radien	Isolationscrimpöhe Insulation Crimp Height ± 0,15	Isolationscrimpbreite Insulation Crimp Width gemessen an den Tangenten der Radien	TE-Kontakt-Nr. TE-Contact no. Ø 1,5 und 2,5 Rundstecker
0,5mm <sup>2</sup>	1,27	2,03 F	2,2	2,54 O	Ø 1,5 / 929986-1 Buchse / Socket Ø 1,5 / 929980-1 Stift / Pin Ø 2,5 / 929970-1 Buchse / Socket Ø 2,5 / 929963-1 Stift / Pin
1,0mm <sup>2</sup>	1,45				
0,75mm <sup>2</sup>	1,36				

POS	TE PN	QTY	DESCRIPTION
1	9-1579016-6	1	HTV10 CRIMP HEAD CONTACTS 0,5-1,0 mm
2	2-1579005-1	1	BASIC HAND TOOL GRIP, SHORT, C

**CUSTOMER MANUAL:  
 411-18595 /2-744017-9**

THIS DRAWING IS A CONTROLLED DOCUMENT.		DWN G.Herold 01OCT2015	TE Connectivity HTV10S HAND TOOL 2.5 DIA.CONTACT 0.5-1.0 SQ.MM																	
DIMENSIONS: mm		CHK G.Stegmayer 01OCT2015																		
TOLERANCES UNLESS OTHERWISE SPECIFIED:		APVD G.Stegmayer 01OCT2015																		
<table border="1"> <tr><td>0</td><td>PLC</td><td>± -</td></tr> <tr><td>1</td><td>PLC</td><td>± -</td></tr> <tr><td>2</td><td>PLC</td><td>± -</td></tr> <tr><td>3</td><td>PLC</td><td>± -</td></tr> <tr><td>4</td><td>PLC</td><td>± -</td></tr> <tr><td colspan="2">ANGLES</td><td>± -</td></tr> </table>		0		PLC	± -	1	PLC	± -	2	PLC	± -	3	PLC	± -	4	PLC	± -	ANGLES		± -
0	PLC	± -																		
1	PLC	± -																		
2	PLC	± -																		
3	PLC	± -																		
4	PLC	± -																		
ANGLES		± -																		
MATERIAL	FINISH	PRODUCT SPEC APPLICATION SPEC WEIGHT 0.29 kg	SIZE A3																	
		CAGE CODE 00779	DRAWING NO C=2-1579024-5																	
		RESTRICTED TO -																		
		SCALE 1:1																		
		SHEET 1 OF 1																		
		REV B																		