

STRAIGHT PLUG FULL CRIMP TYPE

R222.900.100

CABLE 2/50 S

Series : SMP-COM

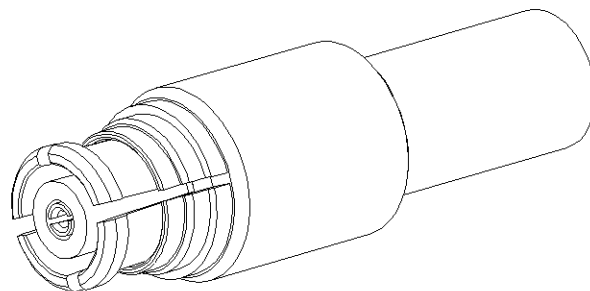
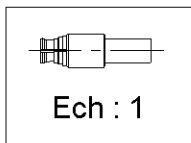
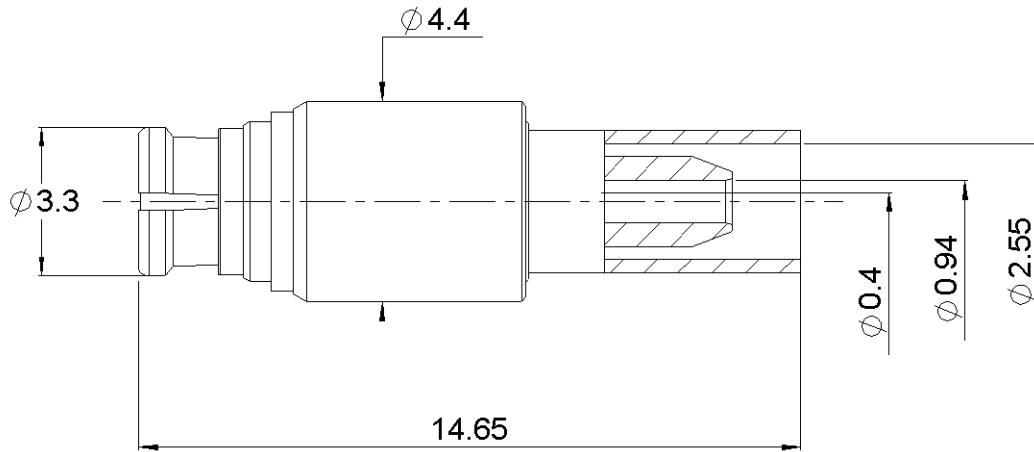

All dimensions are in mm.

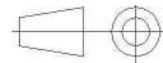

COMPONENTS	MATERIALS	PLATING (µm)
BODY	BRASS	NPGR
CENTER CONTACT	BERYLLIUM COPPER	NPGR
OUTER CONTACT	BERYLLIUM COPPER	NPGR
INSULATOR	PTFE	
GASKET	-	
OTHERS PARTS	BRASS	OR 0.2 SUR NICKEL 2
-	-	-
-	-	-

Issue : 0850 A

In the effort to improve our products, we reserve the right to make changes judged to be necessary.



RADIALL®

STRAIGHT PLUG FULL CRIMP TYPE

R222.900.100

CABLE 2/50 S

Series : SMP-COM

PACKAGING

Standard	Unit	Other
100	'W' option	Contact us

SPECIFICATION

ELECTRICAL CHARACTERISTICS

Impedance	50	Ω
Frequency	0-12.4*	GHz
VSWR	1.15** + 0,0000	x F(GHz) Maxi
Insertion loss	0.12	\sqrt{F} (GHz) dB Maxi
RF leakage	- (55***	- F(GHz)) dB Maxi
Voltage rating	250	Veff Maxi
Dielectric withstanding voltage	750	Veff mini
Insulation resistance	5000	M Ω mini

CABLE ASSEMBLY

Stripping	a	b	c	d	e	f
mm	2,50	5,00	9,00	0,00	6,50	0,00

Assembly instruction : **Crimp 02**

Recommended cable(s)
RG 196
RG 178

Characteristics indicated on this data sheet are those that can be achieved with the highest performance cable. Intrinsic limitations of the cable may diminish the performance of the assembly

Cable retention

- pull off **35** N mini
- torque **NA** N.cm

MECHANICAL CHARACTERISTICS

Center contact retention		
Axial force – Mating end	6.8	N mini
Axial force – Opposite end	6.8	N mini
Torque	NA	N.cm mini

TOOLING

Part Number	Description	Hexagon
.	.	.
R282.967.091	POSITIONER FOR CRIMPING TOOL	-
R282.211.000	CRIMPING TOOL	2.67
R282.235.003	CRIMPING DIES M22520/5-03	2.67
R282.281.000	CRIMPING TOOL	2x4 (pos 2)
R282.293.000	CRIMPING TOOL M22520/5-01	-

Recommended torque		
Mating		N.cm
Panel nut		N.cm
Clamp nut		N.cm
A/F clamp nut	0,0000	mm
Mating life	100	Cycles mini
Weight	0,8800	g

ENVIRONMENTAL

Operating temperature	-55/+125	$^{\circ}$ C
Hermetic seal	NA	Atm.cm3/s
Panel leakage	NA	

OTHER CHARACTERISTICS

*ROS: 1.35 at 12.4GHz
** ROS at 6GHz
***RF Leakage : -40dB min 3<F<6GHz

Issue : 0850 A

In the effort to improve our products, we reserve the right to make changes judged to be necessary.

