



NXP high-gain power doublers CGD104x and push-pulls CGY104x

Highly efficient line-up of 1 GHz GaAs modules for sustainable CATV networks

Designed for 1-GHz “sustainable networks,” these high-performance GaAs devices enable extended bandwidth and higher data rates. They deliver increased network capacity and make way for high-end services like HDTV, VoIP, and digital simulcasting.

Key features

- ▶ Excellent linearity, stability, and reliability
- ▶ High power gain for power doublers
- ▶ Extremely low noise
- ▶ Dark Green products
- ▶ GaAs HFET dies for high-end applications
- ▶ Rugged construction
- ▶ Superior levels of ESD protection

Key benefits

- ▶ Simple upgrade to 1-GHz capable networks
- ▶ Optimized heat management
- ▶ Excellent temperature resistance
- ▶ Low total cost of ownership
- ▶ Very high ESD levels
- ▶ High power-stress capability
- ▶ Highly automated assembly
- ▶ Ringtone surge destruction proof

Key applications

- ▶ Hybrid Fiber Coax (HFC) applications
- ▶ Line extenders
- ▶ Trunk amplifiers
- ▶ Fiber deep-optical-node (N+0/1/2)

The NXP power doublers CGD104xH and CGD104xHi are ideal for use in line extenders and trunk amplifiers. They support fiber deep-optical-node applications (N+0/1/2), delivering the highest output power on the market today. The GaAs HFET die process delivers high gain and high performance, along with lower current and better CTB and CSO ratings.

The new NXP CGY1047 push-pull is the first product on the market combining very low noise, best-in-class distortion parameters, and low “carbon footprint” capabilities. It delivers the best performance for the lowest power consumption, so it reduces OPEX and CO₂ emissions

All of NXP's 1-GHz solutions are designed for durability and offer superior ruggedness, an extended temperature range, high power overstress capabilities, and extremely high ESD levels. As a result, they also reduce the cost of ownership.

The GaAs die is inserted in a unique HVQFN package that is then mounted on thermal vias that manage heat transfer to the heat sink. Temperature-control circuitry keeps the module's high performance stable over a wide range of temperature changes. Assembly is fully automated and requires almost no human intervention, so repeatability remains very high.

Upcoming products

Additional push-pulls, currently under development, will extend the capabilities of the power doublers even further, supporting almost all modern HFC applications. The push-pull CGY1041 will deliver a gain of 21 dB, the CGY1043 a gain of 23 dB.

NXP is also developing a new, highly integrated power doubler. The CGD1047Hi will deliver, in one IC, a 27-dB power gain with 60-dBmV output power and extra ESD protection, for the ultimate in high-quality, distortionless devices.

Quick reference data CATV 1 GHz power doublers and push pulls

Parameters		CATV 1-GHz power doublers					CATV 1-GHz push-pulls		
		CGD1040Hi	CGD1042H	CGD1042Hi	CGD1044H	CGD1044Hi	CGY1041	CGY1043	CGY1047
Power gain (dB)	typ.	21	23	23	25	25	22	24	28
Slope cable equivalent (dB)	typ.	1.5	1.5	1.5	1	1.5	1.5	1.5	1.5
Composite triple beat (dB)	typ.	-69	-69	-69	-69	-69	-62	-64	-62
Composite 2 nd order distortion (dB)	typ.	-68	-68	-68	-68	-68	-62	-64	-64
Noise (@fmax) (dB)	max.	6	6	6	6	6	4	4	4,5
Total current consumption (mA)	typ.	440	450	440	450	440	220	220	250
Frequency range (MHz)	range	40 - 1000	40 - 1000	40 - 1000	40 - 1000	40 - 1000	40 - 1000	40 - 1000	40 - 1000

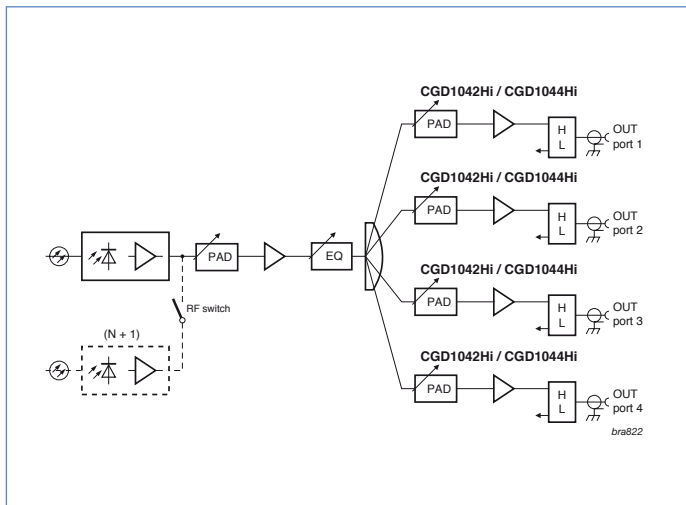

An optical node with multiple out-ports using the CGD1042Hi / CGD1044Hi

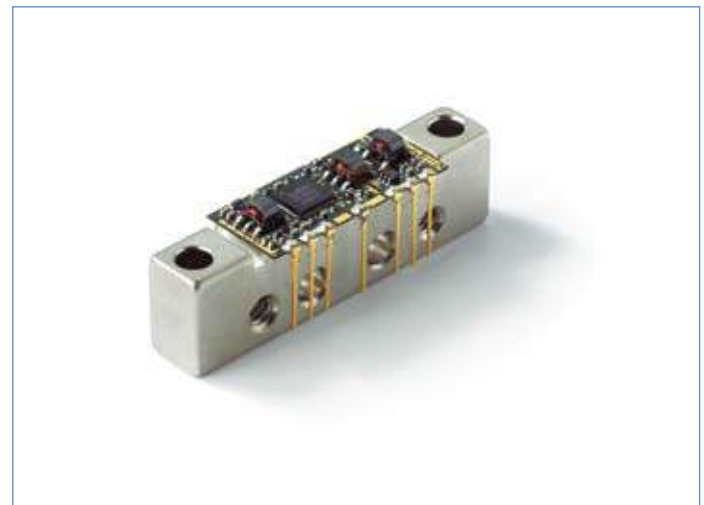

New CATV GaAs platform lay-out