

- Multi-rate up to 3.2Gbps operation
- Wide gain-bandwidth product
 - 38dB differential gain
 - 2GHz 3dB bandwidth
- Low noise 50Ω CML data outputs
 - 800mV_{PP} output swing
 - 60ps edge rates
 - 5ps_{RMS} typ. random jitter
 - 15ps_{PP} typ. deterministic jitter
- Chatter-free, Loss-of-Signal (LOS) output
 - 4.6dB electrical hysteresis
 - OC-TTL output with internal 4.75kΩ pull-up resistor
- Programmable LOS sensitivity using single external resistor
- Internal 50Ω data input termination
- TTL /EN input allows feedback from LOS
- Wide operating range
 - Single 3.3V ±10% or 5V ±10% power supply
 - -40°C to +85°C industrial temperature range
- Available in tiny 10-pin EPAD-MSOP and 16-pin MLF™ packages

- 1.25Gbps and 2.5Gbps Gigabit Ethernet
- 1.062Mbps and 2.125Gbps Fibre Channel
- 155Mbps, 622Gbps, 1.25Gbps, and 2.5Gbps SONET/SDH
- Gigabit interface converter (GBIC)
- Small form factor (SFF) and small form factor pluggable (SFP) transceivers
- Parallel 10G Ethernet
- High-gain line driver and line receiver

The SY88973V low-power, limiting post amplifier is designed for use in fiber optic receivers. The device connects to typical transimpedance amplifiers (TIAs). The linear signal output from TIAs can contain significant amounts of noise and may vary in amplitude over time. The SY88973V quantizes these signals and outputs typically 800mV_{PP} voltage-limited waveforms.

The SY88973V operates from a single +3.3V ±10% or +5V ±10% power supply, over an industrial temperature range of -40°C to +85°C. With its wide bandwidth and high gain, signals with data rates up to 3.2Gbps and as small as 10mV_{PP} can be amplified to drive devices with CML inputs or AC-coupled PECL inputs.

The SY88973V incorporates a loss-of-signal (LOS), open-collector TTL output with internal 4.75kΩ pull-up resistor. A programmable, loss-of-signal level set pin (LOSLVL) sets the sensitivity of the input amplitude detection. LOS asserts high if the input amplitude falls below the threshold set by LOSLVL and de-asserts low otherwise. LOS can be fed back to the enable (/EN) input to maintain output stability under a loss-of-signal condition. /EN de-asserts the true output signal without removing the input signal. Typically 4.6dB LOS hysteresis is provided to prevent chattering.

Please see Micrel's website at www.micrel.com for a complete selection of optical module ICs. The following table summarizes the differences between devices in Micrel's latest family of Limiting Amplifiers.

All support documentation can be found on Micrel's web site at www.micrel.com.

Part Number	Integrated 50Ω Input Termination	LOS or SD	Active LOW or HIGH Enable
SY88773V	No	LOS	LOW
SY88823V	No	SD	HIGH
SY88843V	Yes	SD	HIGH
SY88973V	Yes	LOS	LOW

Table 1. Limiting Amplifiers Selection Guide

3.3V, 25°C, 10mV_{PP} Input
@ 3.2Gbps 2³¹-1 PRBS, R_{LOAD} = 50Ω to V_{CC}

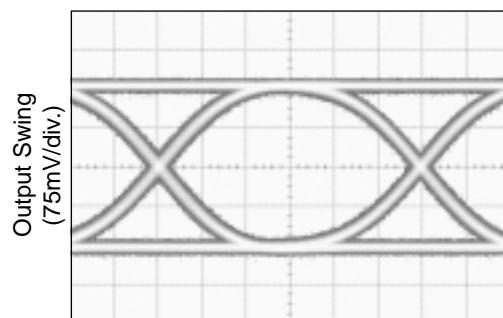

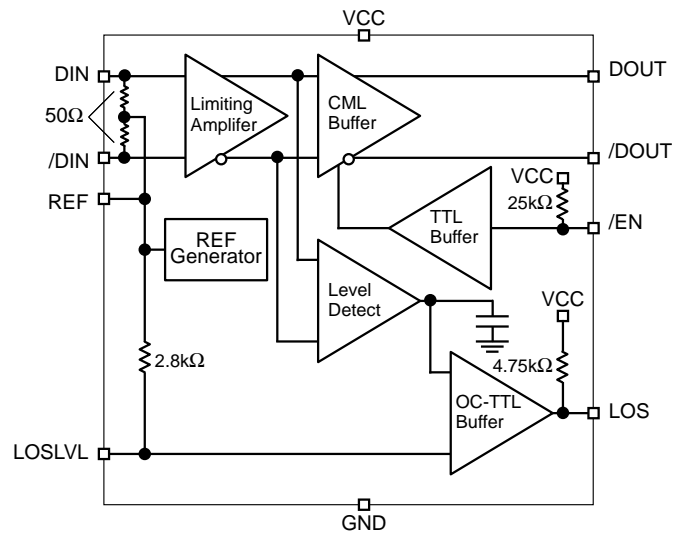

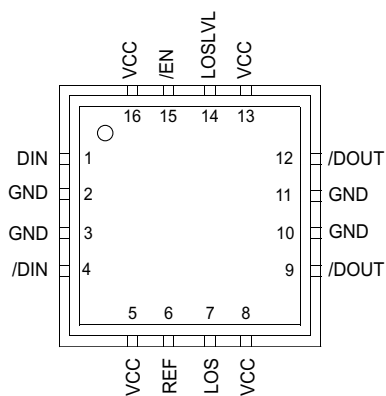

16-Pin MLF™ (MLF-16)

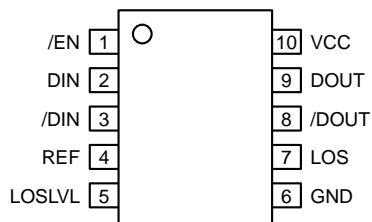

10-Pin EPAD-MSOP (K10-2)

Ordering Information⁽¹⁾

Part Number	Package Type	Operating Range	Package Marking	Lead Finish
SY88973VKI	K10-2	Industrial	973V	Sn-Pb
SY88973VKITR ⁽²⁾	K10-2	Industrial	973V	Sn-Pb
SY88973VMI	MLF-16	Industrial	973V	Sn-Pb
SY88973VMITR ⁽²⁾	MLF-16	Industrial	973V	Sn-Pb
SY88973VEY ⁽³⁾	K10-2	Industrial	973V with Pb-Free bar-line indicator	Pb-Free Matte-Sn
SY88973VEYTR ^(2, 3)	K10-2	Industrial	973V with Pb-Free bar-line indicator	Pb-Free Matte-Sn
SY88973VMG ⁽³⁾	MLF-16	Industrial	973V with Pb-Free bar-line indicator	Pb-Free NiPdAu
SY88973VMGTR ^(2, 3)	MLF-16	Industrial	973V with Pb-Free bar-line indicator	Pb-Free NiPdAu

Notes:

1. Contact factory for die availability. Dice are guaranteed at $T_A = 25^\circ\text{C}$, DC Electricals only.
2. Tape and Reel.
3. Pb-Free package is recommended for new designs.

Pin Number (MSOP)	Pin Number (MLF™)	Pin Name	Type	Pin Function
1	15	/EN	TTL Input: Default is high.	Enable: De-asserts true data output when high. Incorporates 25kΩ pull-up to VCC.
2, 3	1, 4	DIN, /DIN	Differential Data Input	Differential data input. Each pin internally terminates to REF through 50Ω.
4	6	REF		Reference Voltage: Bypass with 0.01μF low ESR capacitor from REF to VCC to stabilize LOSLVL and REF.
5	14	LOSLVL	Input: Default is maximum sensitivity.	Loss-of-Signal level set: A resistor from this pin to VCC sets the threshold for the data input amplitude at which the LOS output will be asserted.
6 Exposed Pad	2, 3, 10, 11 Exposed Pad	GND	Ground	Device ground. Exposed pad must be soldered (or equivalent) to the same potential as the ground pins.
7	7	LOS	Open Collector TTL Output with internal 4.75kΩ pull-up resistor	Loss-of-Signal: asserts high when the data input amplitude falls below the threshold set by LOSLVL.
8, 9	9, 12	DOUT, /DOUT	Differential CML Output	Differential data output.
10	5, 8, 13, 16	VCC	Power Supply	Positive power supply. Bypass with 0.1μF 0.01μF low ESR capacitors. 0.01μF capacitors should be as close as possible to VCC pins.

Absolute Maximum Ratings⁽¹⁾

Supply Voltage (V_{CC})	0V to +7.0V
/EN, LOSLVL Voltage	0 to V_{CC}
REF Current	± 1 mA
LOS Current	± 5 mA
DOUT, /DOUT Current	± 25 mA
DIN, /DIN Current	± 10 mA
Storage Temperature (T_S)	-65°C to +150°C
Lead Temperature (Soldering, 20 sec.)	260°C

Operating Ratings⁽²⁾

Supply Voltage (V_{CC})	+3.0V to +3.6V or +4.5V to +5.5V
Ambient Temperature (T_A)	-40°C to +85°C
Junction Temperature (T_J)	-40°C to +120°C
Package Thermal Resistance ⁽³⁾	
MLF™	
θ_{JA} (Still-Air)	61°C/W
Ψ_{JB}	38°C/W
EPAD-MSOP	
θ_{JA} (Still-Air)	38°C/W
Ψ_{JB}	22°C/W

$V_{CC} = 3.0V$ to $3.6V$ or $4.5V$ to $5.5V$, $T_A = -40^\circ C$ to $+85^\circ C$; typical values at $V_{CC} = 3.3V$, $T_A = 25^\circ C$.

Symbol	Parameter	Condition	Min	Typ	Max	Units
I_{CC}	Power Supply Current	3.3V, Note 4 5V, Note 4		28 30	42 45	mA mA
		3.3V, Note 5 5V, Note 5		45 47	62 65	mA mA
V_{REF}	REF Voltage			$V_{CC}-1.3$		V
V_{LOSLVL}	LOSLVL Voltage Range		V_{REF}		V_{CC}	V
V_{OH}	Output HIGH Voltage	Note 6	$V_{CC}-0.020$	$V_{CC}-0.005$	V_{CC}	V
V_{OL}	Output LOW Voltage	3.3V, Note 6 5V, Note 6	$V_{CC}-0.475$ $V_{CC}-0.510$	$V_{CC}-0.400$ $V_{CC}-0.400$	$V_{CC}-0.350$ $V_{CC}-0.350$	V V
						± 80
V_{OFFSET}	Differential Output Offset	Note 6				
Z_O	Single-Ended Output Impedance		40	50	60	Ω
Z_I	Single-Ended Input Impedance		40	50	60	Ω

$V_{CC} = 3.0V$ to $3.6V$ or $4.5V$ to $5.5V$, $T_A = -40^\circ C$ to $+85^\circ C$.

Symbol	Parameter	Condition	Min	Typ	Max	Units
V_{OH}	LOS Output HIGH Level	Sourcing 100 μ A	2.4		V_{CC}	V
V_{OL}	LOS Output LOW Level	Sinking 2mA			0.5	V
V_{IH}	/EN Input HIGH Voltage		2.0			V
V_{IL}	/EN Input LOW Voltage				0.8	V
I_{IH}	/EN Input HIGH Current	$V_{IN} = 2.7V$ $V_{IN} = V_{CC}$			20 100	μ A μ A
				-0.3		
I_{IL}	/EN Input LOW Current	$V_{IN} = 0.5V$				

Notes:

1. Permanent device damage may occur if Absolute Maximum Ratings are exceeded. This is a stress rating only and functional operation is not implied at conditions other than those detailed in the operational sections of this data sheet. Exposure to Absolute Maximum Rating conditions for extended periods may affect device reliability.
2. The data sheet limits are not guaranteed if the device is operated beyond the operating ratings.
3. Thermal performance assumes the use of 4-layer PCB. Exposed pad must be soldered (or equivalent) to the device's most negative potential on the PCB.
4. Excludes current of CML output stage. See "Detailed Description."
5. Total device current with no output load.
6. Output levels are based on a 50 Ω to V_{CC} load impedance. If the load impedance is different, the output level will be changed. Amplifier is in limiting mode.

$V_{CC} = 3.0V$ to $3.6V$ or $4.5V$ to $5.5V$, $T_A = -40^\circ C$ to $+85^\circ C$, $R_{LOAD} = 50\Omega$ to V_{CC} ; typical values at $V_{CC} = 3.3V$, $T_A = 25^\circ C$.

Symbol	Parameter	Condition	Min	Typ	Max	Units
PSRR	Power Supply Rejection Ratio			35		dB
t_r, t_f	Output Rise/Fall Time (20% to 80%)	Note 7		60	120	ps
t_{JITTER}	Deterministic Random	Note 8		15 5		ps _{PP} ps _{RMS}
V_{ID}	Differential Input Voltage Swing		10		1800	mV _{PP}
V_{OD}	Differential Output Voltage Swing	3.3V, Note 7 5V, Note 7	700 700	800 800	950 1020	mV _{PP} mV _{PP}
HYS	LOS Hysteresis	Note 9	2	4.6	8	dB
t_{OFF}	LOS Release Time			0.1	0.5	μs
t_{ON}	LOS Assert Time			0.2	0.5	μs
V_{SR}	LOS Sensitivity Range	Note 10	10		35	mV _{PP}
B_{-3dB}	-3dB Bandwidth			2.0		GHz
$A_{V(Diff)}$	Differential Voltage Gain		32	38		dB
S_{21}	Single-Ended Small-Signal Gain		26	32		dB

Notes:

- Amplifier in limiting mode. Input is a 200MHz square wave, $t_r < 300ps$.
- Deterministic jitter measured using 2.488Gbps K28.5 pattern, $V_{ID} = 10mV_{PP}$. Random jitter measured using 2.488Gbps K28.7 pattern, $V_{ID} = 10mV_{PP}$.
- Electrical signal.
- This is the detectable range of input amplitudes that can assert LOS. The input amplitude to deassert LOS is 2–8dB higher than the assert amplitude. See "Typical Operating Characteristics" for graphs showing how to choose a particular V_{LOSLVL} or R_{LOSLVL} for a particular LOS assert, and its associated de-assert, amplitude. If increased LOS sensitivity and hysteresis are required, an application note entitled "Notes on Sensitivity and Hysteresis in Micrel Post Amplifiers" is available at http://www.micrel.com/product-info/app_hints+notes.shtml.

$V_{CC} = 3.3V$, $T_A = 25^\circ C$, $R_{LOAD} = 50\Omega$ to V_{CC} , unless otherwise stated.

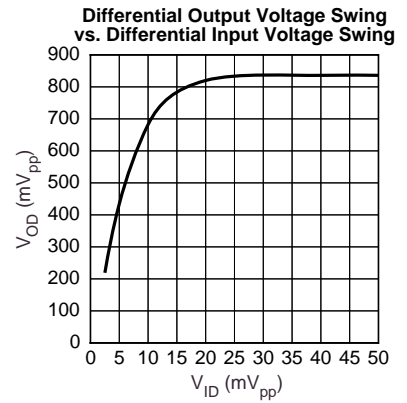
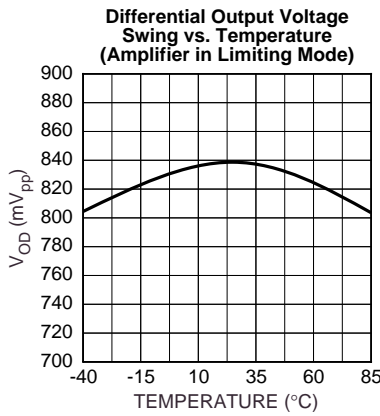
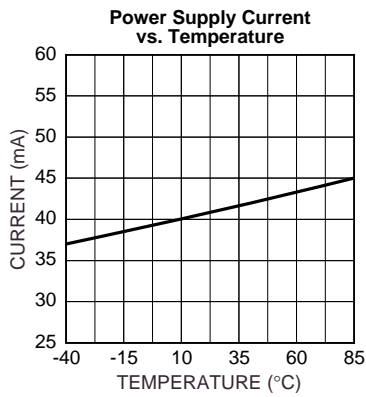
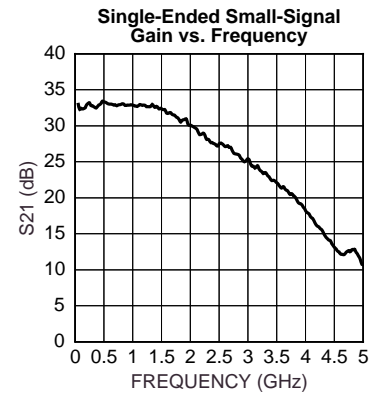
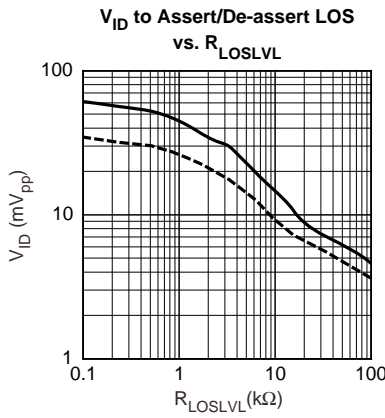
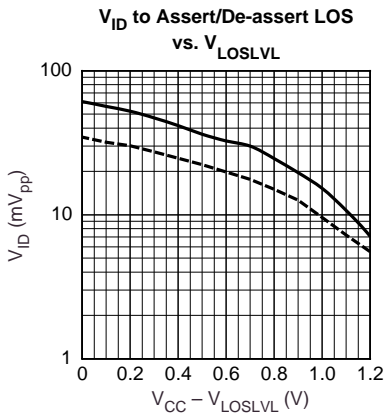
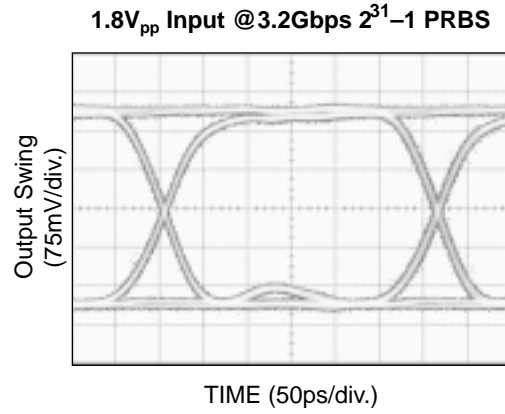
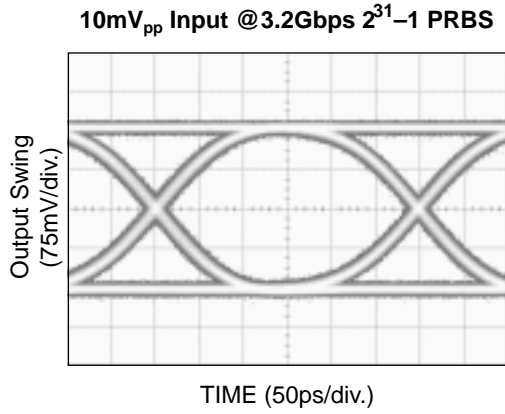

The SY88973V low-power, limiting post amplifier operates from a single +3.3V ±10% or +5V ±10% power supply, over an industrial temperature range of –40°C to +85°C. Signals with data rates up to 3.2Gbps and as small as 10mV_{PP} can be amplified. Figure 1 shows the allowed input voltage swing. The SY88973V generates an LOS output, providing feedback to /EN for output stability. LOSLVL sets the sensitivity of the input amplitude detection.

Input Amplifier/Buffer

The SY88973V's inputs are internally terminated with 50Ω to REF. Unless unaffected by this internal termination scheme, upstream devices need to be AC-coupled to the SY88973V's inputs. Figure 2 shows a simplified schematic of the input structure.

The high sensitivity of the input amplifier detects and amplifies signals as small as 10mV_{PP}. The input amplifier allows input signals as large as 1800mV_{PP}. Input signals are linearly amplified with a typical 38dB differential voltage gain. Since it is a limiting amplifier, the SY88973V outputs, typically 800mV_{PP}, voltage-limited waveforms for input signals that are greater than 10mV_{PP}. Applications requiring the SY88973V to operate with high gain should have the upstream TIA placed as close as possible to the SY88973V's input pins to ensure the device's best performance.

Output Buffer

The SY88973V's CML output buffer is designed to drive 50Ω lines. The output buffer requires appropriate termination for proper operation. An external 50Ω resistor to VCC or equivalent for each output pin provides this. Figure 3 shows a simplified schematic of the output structure and includes an appropriate termination method. Of course, driving a downstream device with a CML input that is internally terminated with 50Ω to VCC eliminates the need for external termination. As noted in the previous section, the amplifier outputs, typically 800mV_{PP}, waveforms across 25Ω total loads. The output buffer, thus, switches typically 16mA tail-current. Figure 4 shows the power supply current measurement which excludes the 16mA tail-current.

Loss-of-Signal

The SY88973V incorporates a chatter-free, LOS open-collector TTL output with internal 4.75kΩ pull-up resistor as shown in Figure 5. LOS is used to determine that the input amplitude is too small to be considered a valid input. LOS asserts high if the input amplitude falls below the threshold set by LOSLVL and de-asserts low otherwise. LOS can be fed back to the enable (/EN) input to maintain output stability under a loss of signal condition. /EN de-asserts low the true output signal without removing the input signals. Typically 4.6dB LOS hysteresis is provided to prevent chattering.

Loss-of-Signal Level Set

A programmable, loss-of-signal level set pin sets the threshold of the input amplitude detection. Connecting an external resistor between VCC and LOSLVL sets the voltage at LOSLVL. This voltage ranges from V_{CC} to V_{REF}. The external resistor creates a voltage divider between VCC and REF as shown in Figure 6. If desired, an appropriate external voltage may be applied rather than using a resistor. The relationship between V_{LOSLVL} and R_{LOSLVL} is given by:

$$V_{\text{LOSLVL}} = V_{\text{CC}} - 1.3 \frac{R_{\text{LOSLVL}}}{R_{\text{LOSLVL}} + 2.8}$$

where voltages are in volts and resistances are in kΩ.

The smaller the external resistor, which implies a smaller voltage difference from LOSLVL to VCC, the lower the LOS sensitivity. Hence, larger input amplitude is required to deassert LOS. The "Typical Operating Characteristics" section contains graphs showing the relationship between the input amplitude detection sensitivity and V_{LOSLVL} or R_{LOSLVL}.

Hysteresis

The SY88973V provides typically 4.6dB LOS electrical hysteresis. By definition, a power ratio measured in dB is 10log(power ratio). Power is calculated as V_{IN}²/R for an electrical signal. Hence, the same ratio can be stated as 20log(voltage ratio). While in linear mode, the electrical voltage input changes linearly with the optical power and the ratios change linearly as well. Therefore, the optical hysteresis in dB is half the electrical hysteresis in dB given in the datasheet. The SY88973V provides typically 2.3dB LOS optical hysteresis. As the SY88973V is an electrical device, this datasheet refers to hysteresis in electrical terms. With 4.6dB LOS hysteresis, a voltage factor of 1.7 is required to deassert LOS.

Hysteresis and Sensitivity Improvement

If increased LOS sensitivity and hysteresis are required, an application note entitled "Notes on Sensitivity and Hysteresis in Micrel Post Amplifiers" is available at http://www.micrel.com/product-info/app_hints+notes.shtml.

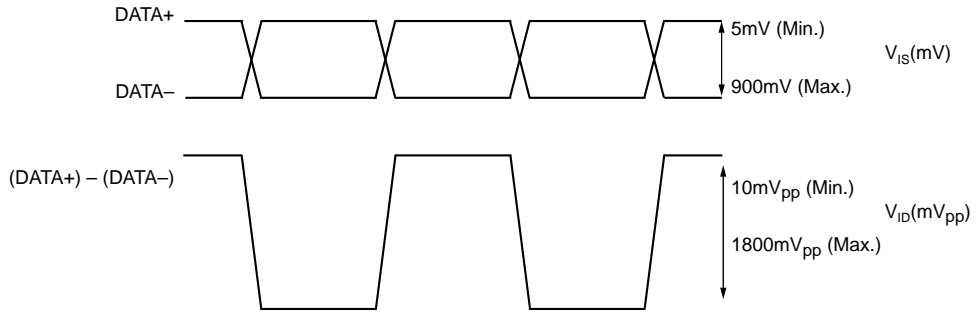

Figure 1. V_{IS} and V_{ID} Definition

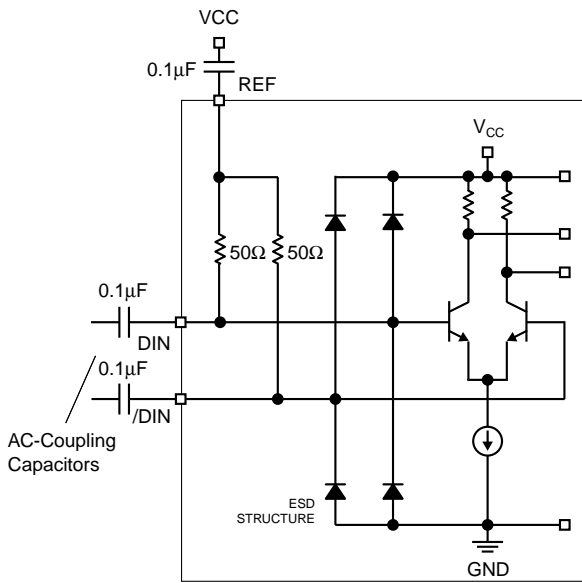

Figure 2. Input Structure

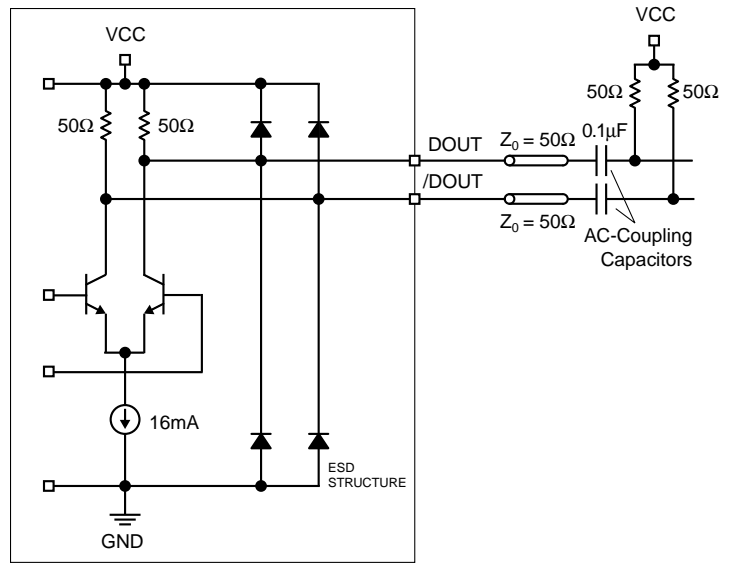

Figure 3. Output Structure

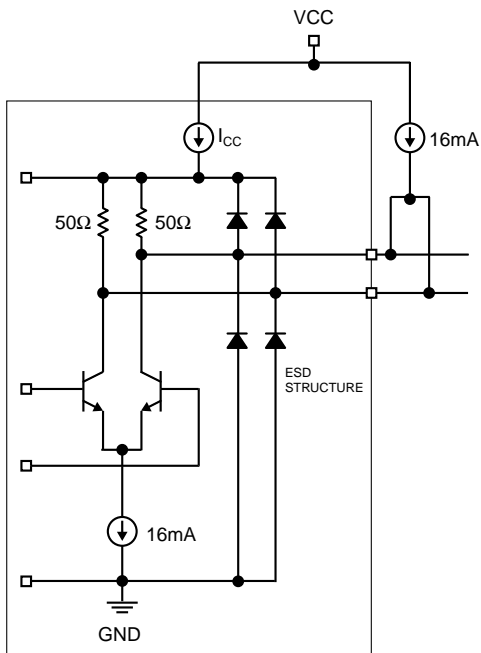

Figure 4. Power Supply Current Measurement

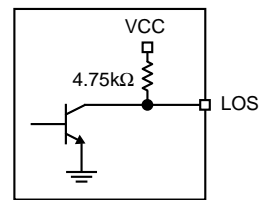

Figure 5. LOS Output Structure

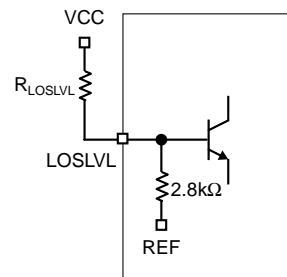
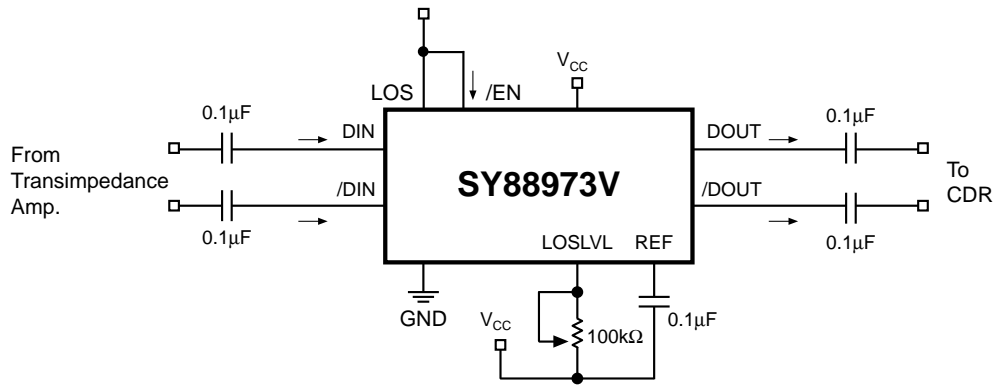
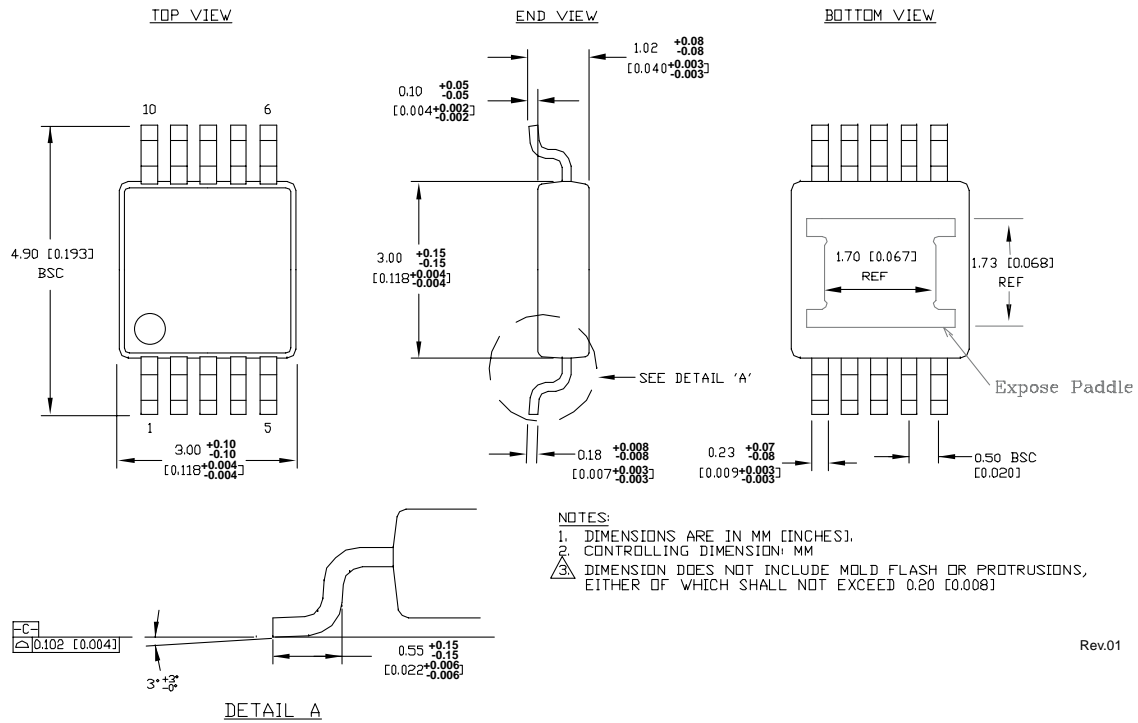

Figure 6. LOSLVL Setting Circuit



Part Number	Function	Data Sheet Link
SY88773V	3.3V/5V 3.2Gbps CML Low-Power, Limiting Post Amplifier w/ TTL LOS	http://www.micrel.com/_PDF/HBW/sy88773v.pdf
SY88823V	3.3V/5V 3.2Gbps CML Low-Power, Limiting Post Amplifier w/ TTL SD	http://www.micrel.com/_PDF/HBW/sy88823v.pdf
SY88843V	3.3V/5V 3.2Gbps CML Low-Power, Limiting Post Amplifier w/ TTL SD	http://www.micrel.com/_PDF/HBW/sy88843v.pdf
SY88973V	3.3V/5V 3.2Gbps CML Low-Power, Limiting Post Amplifier w/ TTL LOS	http://www.micrel.com/_PDF/HBW/sy88973v.pdf
Application Notes	Notes on Sensitivity and Hysteresis in Micrel Post Amplifiers	http://www.micrel.com/product-info/app_hints+notes.shtml



Rev.01

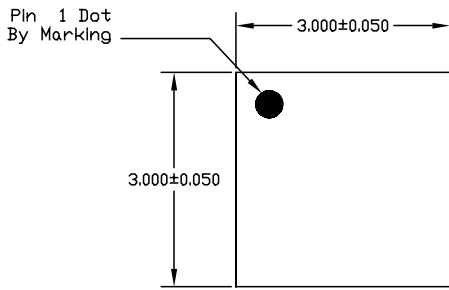

TOP VIEW

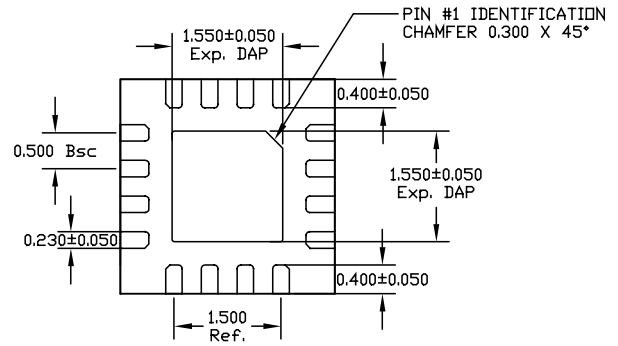

BOTTOM VIEW

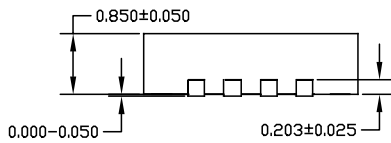

SIDE VIEW

NOTE:

1. ALL DIMENSIONS ARE IN MILLIMETERS.
2. MAX. PACKAGE WARPAGE IS 0.05 mm.
3. MAXIMUM ALLOWABLE BURRS IS 0.076 mm IN ALL DIRECTIONS.
4. PIN #1 ID ON TOP WILL BE LASER/INK MARKED.

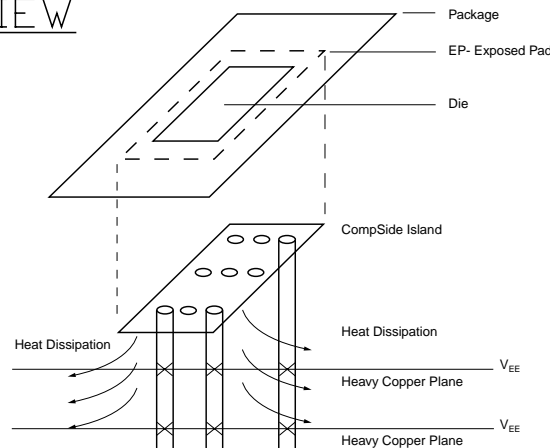

**PCB Thermal Consideration for 16-Pin MLF™ Package
(Always solder, or equivalent, the exposed pad to the PCB)**

Package Notes:

1. Package meets Level 2 qualification.
2. All parts are dry-packaged before shipment.
3. Exposed pads must be soldered to a ground for proper thermal management.

MICREL, INC. 2180 FORTUNE DRIVE SAN JOSE, CA 95131 USA

TEL + 1 (408) 944-0800 FAX + 1 (408) 474-1000 WEB <http://www.micrel.com>

The information furnished by Micrel in this datasheet is believed to be accurate and reliable. However, no responsibility is assumed by Micrel for its use. Micrel reserves the right to change circuitry and specifications at any time without notification to the customer.

Micrel Products are not designed or authorized for use as components in life support appliances, devices or systems where malfunction of a product can reasonably be expected to result in personal injury. Life support devices or systems are devices or systems that (a) are intended for surgical implant into the body or (b) support or sustain life, and whose failure to perform can be reasonably expected to result in a significant injury to the user. A Purchaser's use or sale of Micrel Products for use in life support appliances, devices or systems is at Purchaser's own risk and Purchaser agrees to fully indemnify Micrel for any damages resulting from such use or sale.

© 2005 Micrel, Incorporated.