

IBS IP CDIO/R 24-12/4/8(-SF)

Input/Output Module With Twelve Digital Inputs and Four Digital Outputs

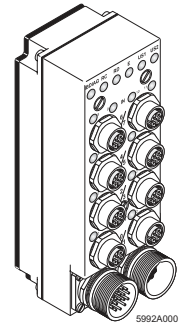

Data Sheet 5992B

05/2004

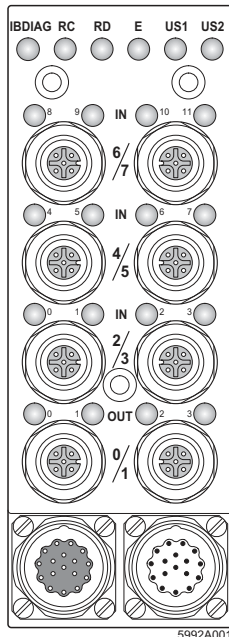

Figure 1 IBS IP CDIO/R 24-12/4/8(-SF)



The IBS IP CDIO/R 24-12/4/8-SF module is a version of the IBS IP CDIO/R 24-12/4/8 module. The differences between the two modules will be noted, otherwise all of the details apply for both module types.



Cover unused M12 sockets with protective caps to ensure IP65 protection.

Product Description

The module is designed for bodyshell manufacturing systems in the automotive industry. It can be mounted directly on a flat mounting surface or on a Kempf terminal box (particularly suitable for SF versions for potential routing).

Both module versions are designed for use with the installation remote bus. The installation remote bus carries the supply voltage for the module and I/O electronics, and also two wire pairs for additional signals.



These modules can only be operated when a controller board with firmware generation G4.x or later is used.

Local Diagnostic and Status Indicators

Des.	Color	Meaning
IBDIAG	Green	ON: Supply voltage present, bus active, no I/O error Flashes (2 Hz): Voltage present, I/O error Flashes (0.5 Hz): Voltage present, bus not active OFF: Supply voltage not present
RC	Green	ON: Incoming remote bus connection established OFF: Incoming remote bus connection defective
RD	Red	ON: Outgoing remote bus disabled OFF: Outgoing remote bus switched on
E	Red	ON: Group message: Overload/short circuit of sensor supply and/or of outputs OFF: No error
US1	Green	ON: Supply voltage for module electronics and sensors present Flashes: Below permissible voltage range OFF: Supply voltage not present
US2	Green	ON: Supply voltage for actuators present Flashes: Below permissible voltage range or voltage not present
IN0 to IN11	Yellow /red	Yellow: Input set, sensor supply present OFF: Input not set, sensor supply present Red: Short circuit/overload of sensor supply (all LEDs of the group of four are red)
OUT0 to OUT3	Yellow /red	Yellow: Output set, no short circuit /overload OFF: Output not set, no short circuit/overload Red: Short circuit/overload of the relevant output

Internal Circuit Diagram

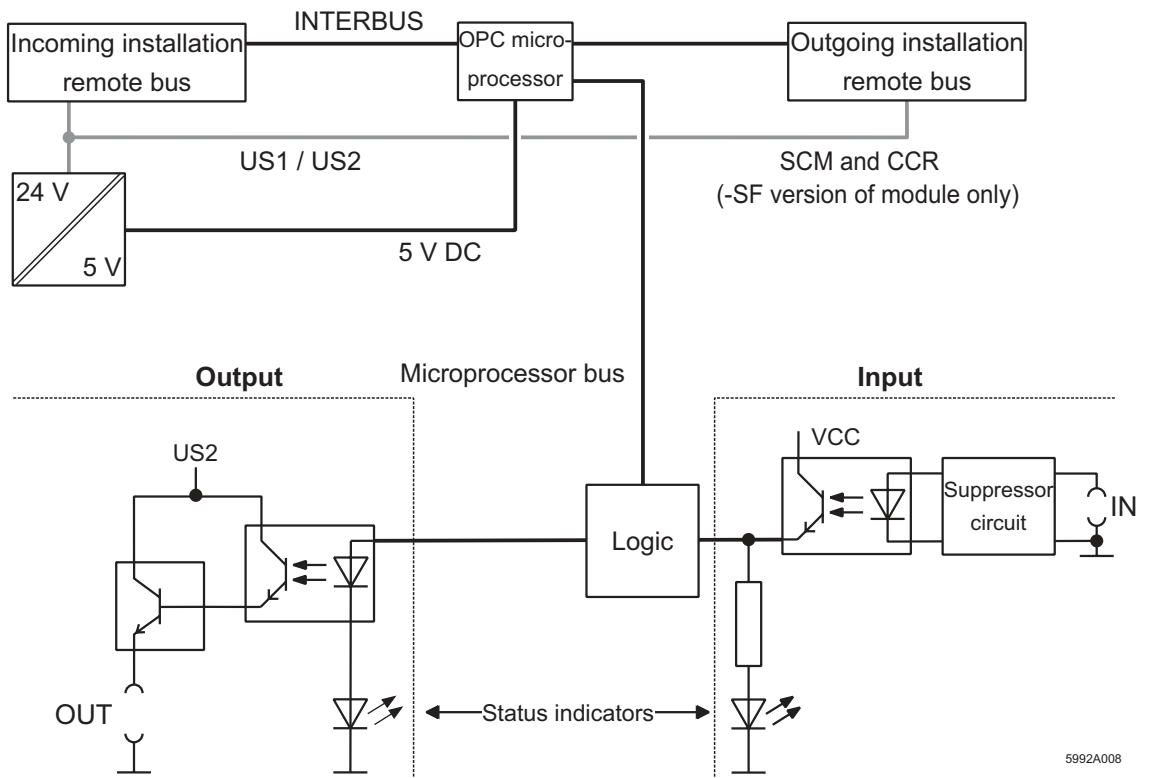

5992A008

Figure 2 Internal circuit diagram

Installation Remote Bus Cable Assembly

Outgoing installation
remote bus

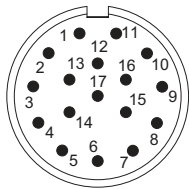

Male
connector
(black)

Assembly
side

Incoming installation
remote bus

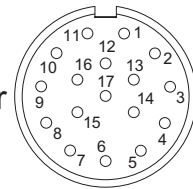

Female
connector
(white)

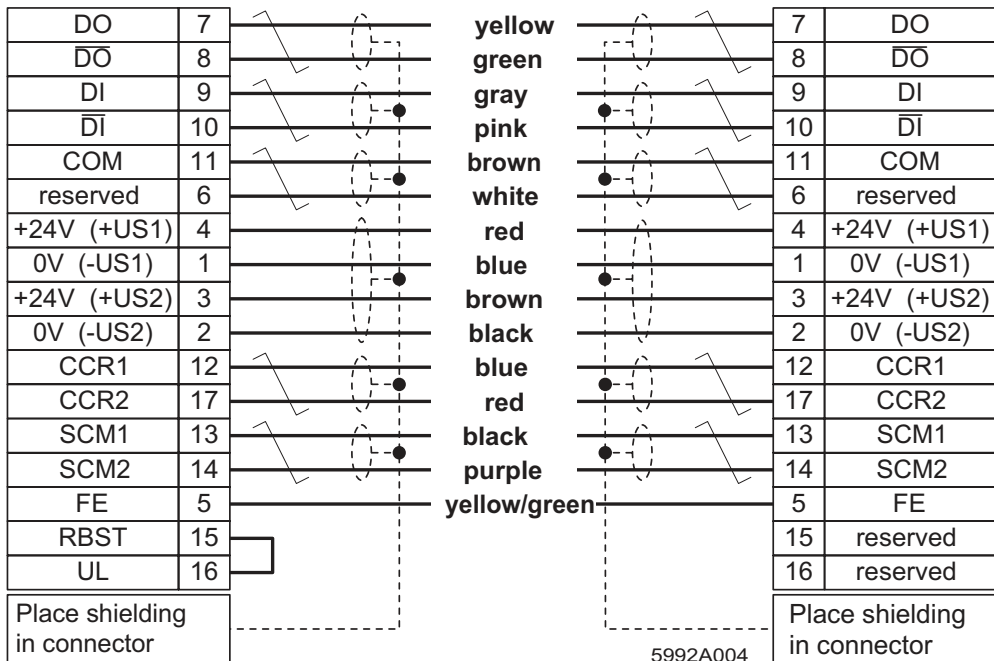

Figure 5 Pin assignment for the installation remote bus cables



Please avoid wiring errors, otherwise the module electronics may be damaged.



Signals CCR and SCM are only required in the special application on welding robots. These two signals are carried in the hybrid cable of the installation remote bus. These signals are **only** supplied for the SF version through an opening in the module base plate.

I/O Devices

Position of the Connectors and Status Indicators on the Module

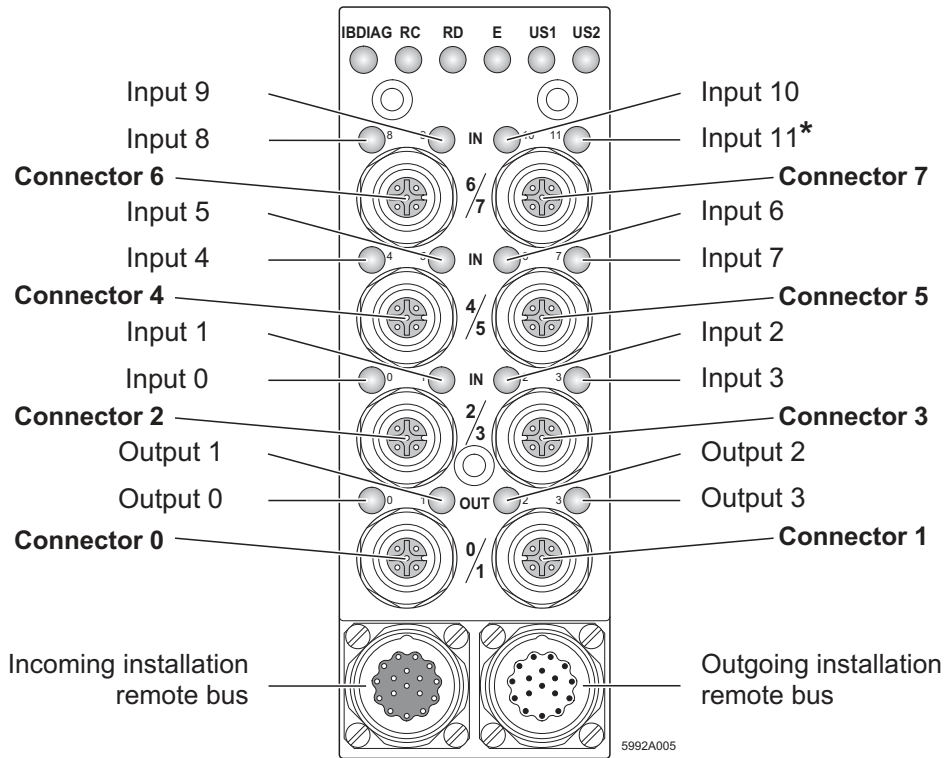

Figure 6 Position of the connectors and status indicators on the module

* **Only** in the SF version input 11 is permanently connected **in** the module to the thermostatic switch input on the bottom of the housing and has no connection to connector 7.

Position of the Signals on the Individual Connectors

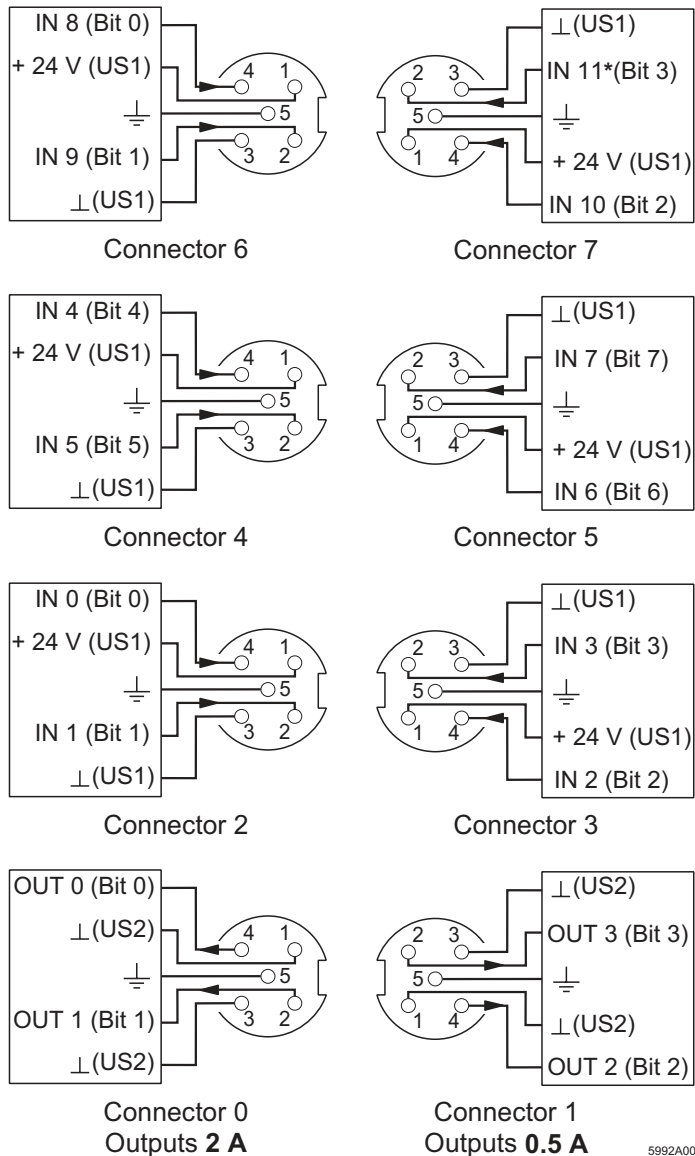

Figure 7 Signal assignment of the connectors

* **Only** in the SF version input 11 is permanently connected in the module to the thermostatic switch input on the bottom of

the housing and has no connection to connector 7.

Connection of Additional Signals for the SF Version

For the SF module version, the following additional signals can be connected to spring-cage terminals on the bottom of the module: CCR to control the welding current, SCM for secondary circuit monitoring of the welding transformer and the signal from a thermostatic switch which monitors the temperature of the welding transformer. Signals CCR and SCM are

supplied directly in the hybrid cable and evaluated by the welding controller. The input for the thermostatic switch is permanently connected in the module to input 11. This means that if you are using the thermostatic switch connector, input 11 cannot be used to connect sensors.

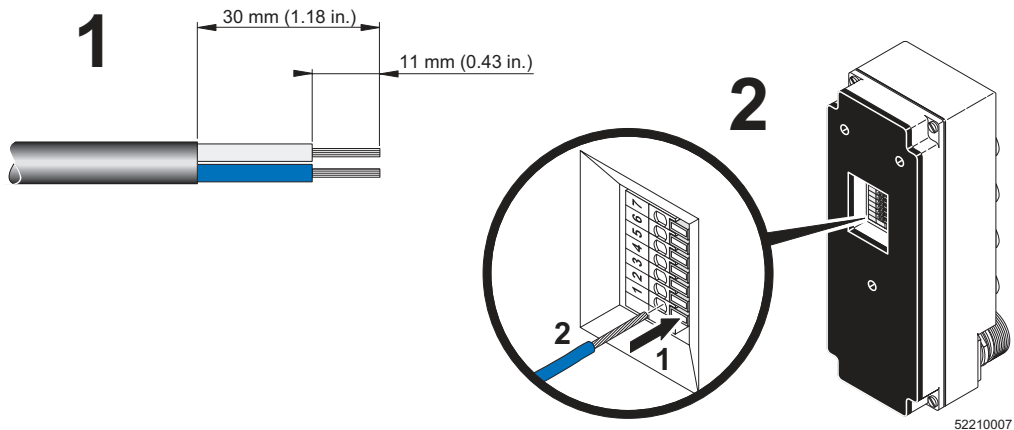
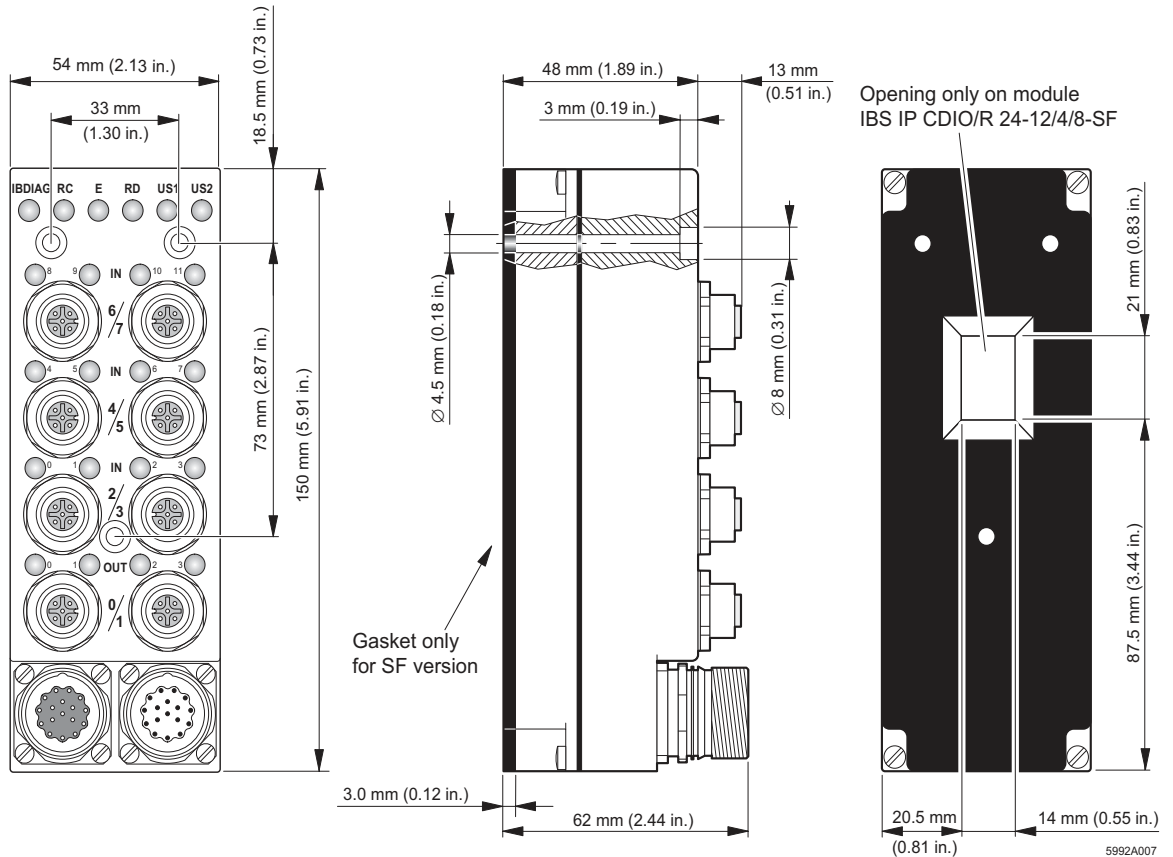

Figure 8 Terminal block base on the module bottom (SF version only)

Assignment of the terminal block base

Terminal	Signal
1	+24 V DC (US1) sensor supply (thermostatic switch)
2	Input signal for thermostatic switch (permanently connected to input 11)
3	GND US1
4	Constant current regulation 1 (CCR1)
5	Constant current regulation 2 (CCR2)
6	Secondary circuit monitoring 1 (SCM1)
7	Secondary circuit monitoring 2 (SCM2)

Housing Dimensions



Programming Data

ID code	03 _{hex} (03 _{dec})
Length code	01 _{hex}
Input address area	2 bytes
Output address area	2 bytes
Parameter channel (PCP)	0 bytes
Register length (bus)	2 bytes

Assignment of Inputs to the INTERBUS Process Data Input Word

INTERBUS reference	Word	Word 0															
	Bit	15	14	13	12	11	10	9	8	7	6	5	4	3	2	1	0
"Byte-bit" view	Byte	Byte 0								Byte 1							
	Bit	7	6	5	4	3	2	1	0	7	6	5	4	3	2	1	0
Module	Connector	5	5	4	4	3	3	2	2	Not used				7	7	6	6
	Channel/input	7	6	5	4	3	2	1	0	Not used				11	10	9	8

Assignment of Outputs to the INTERBUS Process Data Output Word

INTERBUS reference	Word	Word 0															
	Bit	15	14	13	12	11	10	9	8	7	6	5	4	3	2	1	0
"Byte-bit" view	Byte	Byte 0								Byte 1							
	Bit	7	6	5	4	3	2	1	0	7	6	5	4	3	2	1	0
Module	Connector	Not used				1	1	0	0	Not used							
	Channel/output	Not used				3	2	1	0	Not used							

Technical Data

General	
Housing dimensions (width x height x depth)	54 mm x 150 mm x 62 mm (2.126 in. x 5.906 in. x 2.441 in.) (without connectors)
Operating mode	Process data operation with one word
Type of sensor connection	4-wire technology
Type of actuator connection	3-wire technology
Total power consumption	See "Power Consumption" table on page 12
Permissible operating temperature	0°C to 55°C (32°F to 131°F)
Permissible storage temperature	-25°C to 70°C (-13°F to +158°F)
Degree of protection	IP65, DIN 40050, IEC 60529
Class of protection	Class 3 VDE 0106; IEC 60536
Humidity (operation)	100% not condensing
Humidity (storage)	95% not condensing
Air pressure (operation)	86 kPa to 108 kPa, 1500 m (4921 ft.) above sea level
Air pressure (storage)	66 kPa to 108 kPa, 3500 m (11483 ft.) above sea level
Isolated groups	Test voltage
Supply voltage US1; sensor supply	500 V AC; 50 Hz for 1 minute
Supply Voltage US2	500 V AC; 50 Hz for 1 minute
Bus logic, incoming and outgoing remote bus	500 V AC; 50 Hz for 1 minute
Preferred mounting position (for SF version)	Mounted on Kempf terminal box
Functional earth ground connection	Via 17-pos. installation remote bus connector
Weight	560 g, typical

Interface	
INTERBUS installation remote bus	17-pos. circular connector

Connection of Additional Signals for the SF Version	
Spring-cage terminal Connection capacity (solid, stranded)	0.14 mm ² - 0.5 mm ² (26 AWG - 20 AWG)

Power Consumption	
Voltage for the bus interface	24 V DC (US1)
Current consumption of the bus interface	120 mA, maximum
Voltage for the sensor supply	24 V DC (US1)
Current consumption of the sensors	600 mA, maximum
Total consumption from US1	3.5 W, maximum
Actuator supply voltage (US2)	24 V DC
Module power consumption at US2	2.5 W, maximum
Total power consumption	6.0 W, maximum

Supply Voltage (US1)	
Nominal value	24 V DC
Permissible voltage range	18.5 V DC to 32 V DC, ripple included
Permissible ripple	3.6 V _{PP}
Total current consumption at US1	720 mA
Diagnostics	Status indicator on the front of the module
The voltage US1 is looped through the modules and can be tapped from the connection of the outgoing installation remote bus. The maximum continuous current carrying capacity is 7 A.	

Sensor Supply Voltage	
Nominal value	US1 minus 1 V
Nominal current	600 mA total; 50 mA per input
Derating	No derating
Protective functions	Electronic overload/short circuit protection
The sensors are grouped in groups of four and each group is supplied by a short-circuit protected supply.	

Digital Inputs	
Number	12 inputs (only in the SF version input 11 is permanently connected in the module to the thermostatic switch input on the bottom of the housing and has no connection to connector 7).
Signal level (DIN 19240): Logic 0 Logic 1	-30 V to +5 V 13 V to 30 V
Delay when changing signal	3 ms, typical
Nominal current per input	3.0 mA at 24 V, typical
Permissible residual current, "0" signal	1.5 mA, typical
Input groups	The inputs for connectors 2 and 3, 4 and 5, and 6 and 7, respectively, are grouped together.
Diagnostics	Status indicator per input. The failure of the sensor supply is reported via the bus, and the error message is reset by an acknowledgment in the host.

Supply Voltage (US2)	
Nominal value	24 V DC
Permissible voltage range	18.5 V DC to 32 V DC, ripple included
Permissible ripple	3.6 V _{PP}
Total current consumption at US2	5 A
Diagnostics	Status indicator on the front of the module
The voltage US2 is looped through the modules and can be tapped to the connection for the outgoing remote bus. The maximum continuous current carrying capacity is 7 A.	

Digital Outputs	
Number	4 outputs; 2 with a nominal current of 2 A per channel on connector 0; 2 with a nominal current of 0.5 A per channel on connector 1
Minimum output voltage at nominal current	US2 minus 1 V
Derating	No derating
Concurrent channel derating	None

Digital Outputs (Continued)	
Limitation of the voltage induced on circuit interruption	Up to -20 V, approximately
Protection when ground connection interrupted	Yes
Maximum leakage current, "0" signal	≤0.8 mA
Protective functions	Electronic short-circuit protection, free running circuit
Diagnostics	Yellow status indicator for each output; color changes to red in the event of an error; short-circuit/overload message via the bus, and storage in volatile memory on the module; the error message is reset by an acknowledgment in the host.

Electromagnetic Compatibility	
Emitted interference according to EN 55011	Class A
Immunity to interference according to EN 61000-4-2; IEC 61000-4-2 (ESD)	Class 3, Criterion 2
Immunity to interference according to EN 61000-4-3; IEC 61000-4-3	10 V/m; Criterion 1
Immunity to interference according to EN 61000-4-4; IEC 61000-4-4 (burst)	Class 4; Criterion 2
Immunity to interference according to EN 61000-4-5 (surge)	Class 2; Criterion 2
Immunity to interference according to IEC 61000-4-6 (conducted)	10 V
Voltage dips according to NAMUR NE21	0 ms ↔ 20 ms; repeat rate 1 s; criterion 1

Mechanical Capability	
Vibration according to IEC 60068-2-6 (operation)	5g; Criterion 1
Shock according to IEC 60068-2-27	30g
Degree of protection	IP65 when mounted; cover unused connectors with protective caps

Ordering Data

Description	Order Designation	Order No.
Digital input/output module	IBS IP CDIO/R 24-12/4/8	27 30 06 4
Digital input/output module with special functions	IBS IP CDIO/R 24-12/4/8-SF	27 30 07 7
Protective caps for unused sensor/actuator connections (5 pcs.)	IBS IP PROT IO	27 59 91 9
Crimping pliers	CRIMPFOX RC 2,5	12 05 44 8
Remote bus connector: Male connector, straight	TGGM/CDIO/17-ST	16 67 89 5
Female connector, straight	TGGM/CDIO/17-BU	16 67 90 5
Male connector, angled	TWGM/CDIO/17-ST	16 67 95 0
Female connector, angled	TWGM/CDIO/17-BU	16 67 96 3



Make sure you always use the latest documentation.
It can be downloaded at www.phoenixcontact.com.

Phoenix Contact GmbH & Co. KG
Flachsmarktstr. 8
32825 Blomberg
Germany



+ 49 - (0) 52 35 - 3-00



+ 49 - (0) 52 35 - 3-4 12 00



www.phoenixcontact.com



Worldwide Locations:

www.phoenixcontact.com/salesnetwork