



MAX15026B Evaluation Kit

General Description

The MAX15026B evaluation kit (EV kit) is a fully assembled and tested PCB that contains all the components necessary to evaluate the performance of the MAX15026B 10A synchronous step-down controller.

The MAX15026B EV kit requires a 5V to 16V power supply that provides up to 4A for normal operation. The MAX15026B EV kit output is configured to 1.5V and delivers up to 10A output current. The controller switching frequency is programmed to 600kHz. The MAX15026B EV kit includes PCB pads to enable the circuit and to monitor the power-good output.

Features

- ◆ 5V to 16V Input Range
- ◆ Optional 4.5V to 5.5V Input Range for MAX15026B IC
- ◆ 1.5V at 10A Output
- ◆ 600kHz Switching Frequency
- ◆ Enable Input
- ◆ Power-Good Output
- ◆ Fully Assembled and Tested

Ordering Information

PART	TYPE
MAX15026BEVKIT+	EV Kit

+Denotes lead-free and RoHS compliant.

Component List

DESIGNATION	QTY	DESCRIPTION
C1	1	330 μ F \pm 20%, 25V electrolytic capacitor (10mm x 10.2mm) Panasonic EEEFC1E331P
C2	1	4.7 μ F \pm 10%, 25V X5R ceramic capacitor (0805) Murata GRM21BR61E475K
C3	1	1 μ F \pm 10%, 25V X5R ceramic capacitor (0603) Murata GRM188R61E105K
C4	1	4.7 μ F \pm 10%, 6.3V X5R ceramic capacitor (0603) Murata GRM188R60J475K
C5	1	2.2 μ F \pm 10%, 6.3V X5R ceramic capacitor (0603) Murata GRM188R60J225K
C6	1	10 μ F \pm 10%, 25V X5R ceramic capacitor (1206) Murata GRM31CR61E106K
C7	0	Not installed, ceramic capacitor (1206)
C8	1	0.47 μ F \pm 10%, 16V X7R ceramic capacitor (0603) Murata GRM188R71C474K
C9	1	2700pF \pm 5%, 50V C0G ceramic capacitor (0805) Murata GRM2165C1H272JA
C10	1	470 μ F \pm 20%, 4V electrolytic capacitor (8mm x 10.5mm) SANYO 4CE470EX
C11, C12	2	22 μ F \pm 10%, 6.3V X5R ceramic capacitors (1206) Murata GRM31CR60J226K

DESIGNATION	QTY	DESCRIPTION
C13	1	68pF \pm 5%, 50V C0G ceramic capacitor (0603) Murata GRM1885C1H680J
C14	1	15pF \pm 5%, 50V C0G ceramic capacitor (0603) Murata GRM1885CH150J
C15	1	1500pF \pm 10%, 50V C0G ceramic capacitor (0603) Murata GRM1885C1H152K
C16	1	2200pF \pm 5%, 50V C0G ceramic capacitor (0603) Murata GRM1885C1H222J
C17	0	Not installed, ceramic capacitor (0603)
JU1	1	3-pin header
JU2	1	2-pin header
L1	1	1.4 μ H, 22A inductor Coilcraft MSS1278-142ML
N1	1	30V, 74A n-channel MOSFET (SO-8FL) ON Semiconductor NTMFS4837NT1G
N2	1	30V, 104A n-channel MOSFET (SO-8FL) ON Semiconductor NTMFS4835NT1G
PGND (2), VIN, VOUT	4	Uninsulated banana jacks
TP1, TP2	2	PC mini red test points
R1, R6, R8	0	Not installed, resistors (0603)
R2	1	200k Ω \pm 1% resistor (0603)
R3	1	10 Ω \pm 5% resistor (0603)
R4	1	51k Ω \pm 5% resistor (0603)

Evaluates: MAX15026B



MAX15026B Evaluation Kit

Component List (continued)

DESIGNATION	QTY	DESCRIPTION
R5	1	2.2Ω ±5% resistor (0603)
R7	1	1Ω ±1% resistor (1210)
R9	1	11.8kΩ ±1% resistor (0603)
R10	1	22.6kΩ ±1% resistor (0603)
R11	1	5.9kΩ ±1% resistor (0603)
R12	1	15.4kΩ ±1% resistor (0603)
R13	1	10kΩ ±1% resistor (0603)
R14	1	27kΩ ±1% resistor (0603)

DESIGNATION	QTY	DESCRIPTION
R15	1	49.9Ω ±1% resistor (0805)
U1	1	10A synchronous step-down controller (14 TDFN-EP*) Maxim MAX15026BETD+ (Top Mark: +ADP)
—	2	Shunts (JU1, JU2)
—	1	PCB: MAX15026B Evaluation Kit+

*EP = Exposed pad.

Component Suppliers

SUPPLIER	PHONE	WEBSITE
Coilcraft, Inc.	847-639-6400	www.coilcraft.com
Murata Electronics North America, Inc.	770-436-1300	www.murata-northamerica.com
ON Semiconductor	602-244-6600	www.onsemi.com
Panasonic Corp.	800-344-2112	www.panasonic.com
SANYO Electric Co., Ltd.	619-661-6835	www.sanyodevice.com

Note: Indicate that you are using the MAX15026B when contacting these component suppliers.

Quick Start

Required Equipment

Before beginning, the following equipment is needed:

- MAX15026B EV kit
- Adjustable 5V to 16V, 4A DC power supply
- Electronic load capable of sinking 10A (e.g., HP6060B)
- Two voltmeters

Procedure

The MAX15026B EV kit is fully assembled and tested. Follow the steps below to verify board operation.

Caution: Do not turn on the power supply until all connections are completed.

- 1) Install a shunt across pins 1-2 of jumper JU1 (VIN input source for U1).
- 2) Install a shunt at jumper JU2 (VOUT enabled).
- 3) Connect a voltmeter to the VOUT and PGND pads.
- 4) Connect a voltmeter to the PGOOD and AGND pads.
- 5) Connect a 10A electronic load to the VOUT and PGND banana jack connectors.
- 6) Connect a DC power supply to the VIN and PGND banana jack connectors and set the voltage to 12V.
- 7) Enable the power supply.

- 8) Enable the electronic load and set it to 10A.
- 9) Verify that the voltmeters at VOUT and PGOOD are 1.5V and approx 5.2V, respectively.

Detailed Description of Hardware

The MAX15026B EV kit is a fully assembled and tested PCB that contains all the components necessary to evaluate the performance of the MAX15026B 10A synchronous step-down controller. The circuit uses a MAX15026B step-down controller IC to implement a step-down synchronous DC-DC converter circuit. The MAX15026B EV kit is designed to operate from a single DC power supply that provides 5V to 16V and 4A of current. The MAX15026B controller can also be operated using a separate 4.5V to 5.5V power source applied at the VCC and AGND PCB pads. When operating the MAX15026B EV kit using separate power-supply sources at the VIN connector and VCC PCB pad, apply power at the VIN and PGND connectors first and then the VCC and AGND PCB pads.

The MAX15026B EV kit converter is configured to 1.5V and provides up to 10A output current. The switching frequency is set to 600kHz using resistor R14. The EV kit features PCB pads to evaluate the enable input signal (EN) and to monitor the power-good (PGOOD) and VCC output signals.

MAX15026B Evaluation Kit

Evaluates: MAX15026B

Converter Input Source

Banana jack connectors VIN and PGND are used as the power source for the converter. The MAX15026B EV kit converter output performance is optimized over the 5V to 16V VIN input voltage range and up to 10A output current. The MAX15026B EV kit can operate above the 16V maximum input-voltage range and at higher output currents; however, performance may be degraded due to the limitation of the components used in the circuit.

MAX15026B IC Bias Input (JU1)

The MAX15026B EV kit features an option to select the bias input for the MAX15026B IC controller when configuring the EV kit to operate with an input source less than 6V. Jumper JU1 selects the input-voltage source for the MAX15026B IC controller. Place a shunt across pins 1-2 to power the MAX15026B IC using the power source applied at the VIN and PGND banana jack connectors. Place a shunt across pins 2-3 to power the MAX15026B IC input using the power source applied at the VCC and AGND PCB pads. Note that the power source applied to the VCC PCB pad has a 4.5V to 5.5V input-voltage range. When operating the MAX15026B EV kit using separate power-supply sources at the VIN connector and VCC PCB pad, apply power at the VIN and PGND connectors first and then the VCC and AGND PCB pads.

Table 1. MAX15026B Bias Input Configuration (JU1)

SHUNT POSITION	MAX15026B IN PIN	MAX15026B IC INPUT RANGE (V)
1-2	Connected to VIN	5 to 16
2-3	Connected to VCC	4.5 to 5.5

Configuring the Output Voltage (VOUT)

VOUT voltage can be reconfigured between 0.6V to $0.85 \times V_{IN}$. To configure the EV kit's output voltage, refer to the *Setting the Output Voltage* section in the MAX15026 IC data sheet for instructions on selecting new resistor values.

Capacitors C13–C16 and resistors R10 and R11 provide a compensation network for VOUT on the MAX15026B EV kit.

Refer to the *Inductor Selection*, *Input Capacitor Selection*, and the *Compensation* sections in the MAX15026 IC data sheet to verify whether other components need replacement for proper operation after reconfiguring the output voltage.

Current-Limit Thresholds

The MAX15026B IC employs a current-sensing algorithm using the on-resistance of the low-side MOSFET as a current-sensing element to limit the inductor current. The inductor current is sensed in the converter by sensing the voltage drop across the on-resistance $R_{DS(on)}$ of the low-side MOSFET (N2). The MAX15026B EV kit's valley and sink current limits are set to approximately 16.5A and 8A, respectively.

Resistor R9 sets VOUT valley current-limit voltage thresholds (V_{ITH}) to 59mV. The sink current-limit voltage threshold is approximately half the valley current-limit voltage threshold. Use the following equation to reconfigure the valley current-limit voltage threshold:

$$R_{LIM_} (\Omega) = \frac{V_{ITH} \times 10}{50 \times 10^{-6}}$$

where V_{ITH} is the valley current-limit voltage threshold in volts and $R_{LIM_}$ is R9 in ohms.

Refer to the *Current Limit Circuit (LIM)* and *Setting the Valley Current Limit* sections in the MAX15026 IC data sheet for further instructions on computing the MAX15026B EV kit valley and sink current limits.

A PCB pad for resistor R8 is provided to implement foldback current-limit capabilities, if required.

Switching Frequency

The MAX15026B controller switching frequency is set to 600kHz by resistor R14. Replace resistor R14 with a new resistor value to program the switching frequency between 200kHz and 2MHz. Use the following equation to calculate R14 when reconfiguring the switching frequency:

$$R14 = \frac{17.3 \times 10^9}{f_{SW} + (1 \times 10^{-7}) \times (f_{SW}^2)}$$

where f_{SW} is in hertz and R14 is in ohms.

When reconfiguring the EV kit controller switching frequency, it may be necessary to change the compensation network component to new values. Refer to the *Compensation* section in the MAX15026 IC data sheet for computing new compensation component values.

Power-Good Output (PGOOD)

The MAX15026B EV kit provides a PCB pad to monitor the status of the power-good output. PGOOD is high when VOUT rises 94.5% (typ) above its programmed output voltage. When VOUT falls below 92% (typ) of its nominal regulated voltage, PGOOD is pulled low.

MAX15026B Evaluation Kit

Enable Control (JU2)

Jumper JU2 configures the MAX15026B EV kit's output for turn-on/turn-off control. Install a shunt across jumper JU2 to enable VOUT. VOUT is disabled or can also be externally controlled by placing an independent voltage source at the EN and AGND PCB pad when a shunt is not installed at jumper JU2. An additional PCB resistor pad (R1) is included to set the output to a desired turn-on voltage.

Table 2. Enable Control (JU2)

SHUNT POSITION	EN PIN	VOUT OUTPUT
Installed	Connected to VCC	Enabled
Not installed	Pulled down to AGND through R2	Disabled or voltage source applied at EN PCB pad

MAX15026B Evaluation Kit

Evaluates: MAX15026B

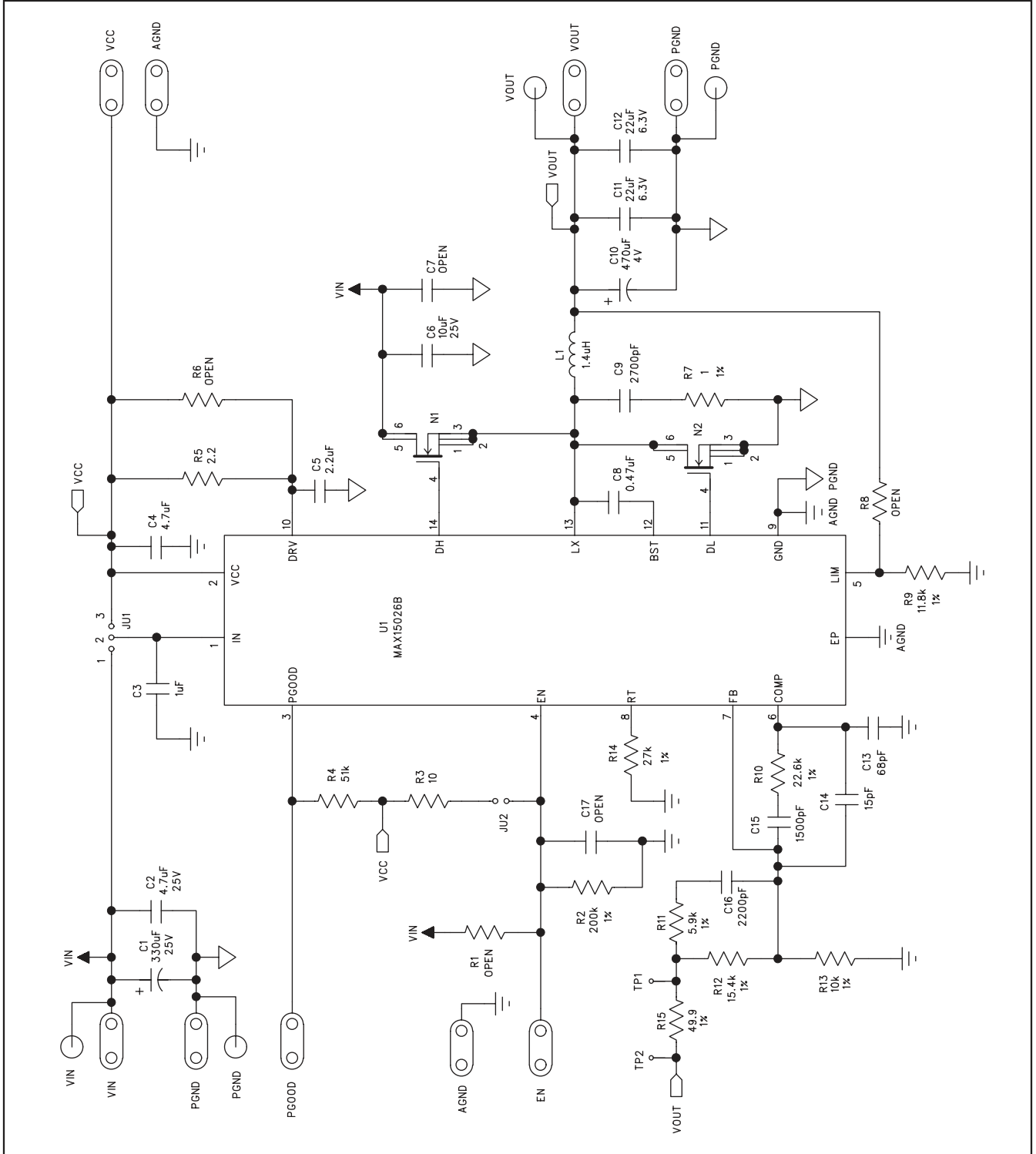

Figure 1. MAX15026B EV Kit Schematic

MAX15026B Evaluation Kit

Evaluates: MAX15026B

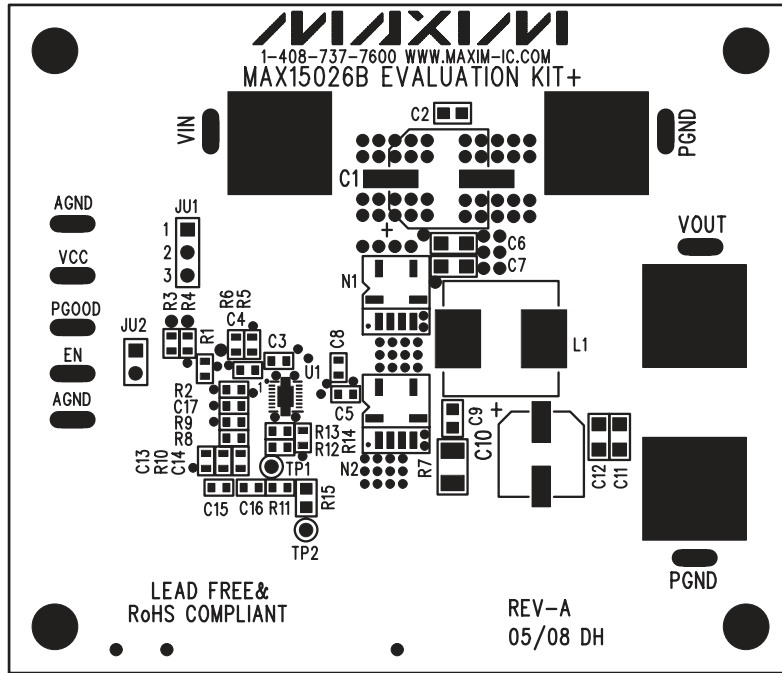

Figure 2. MAX15026B EV Kit Component Placement Guide—Component Side

MAX15026B Evaluation Kit

Evaluates: MAX15026B

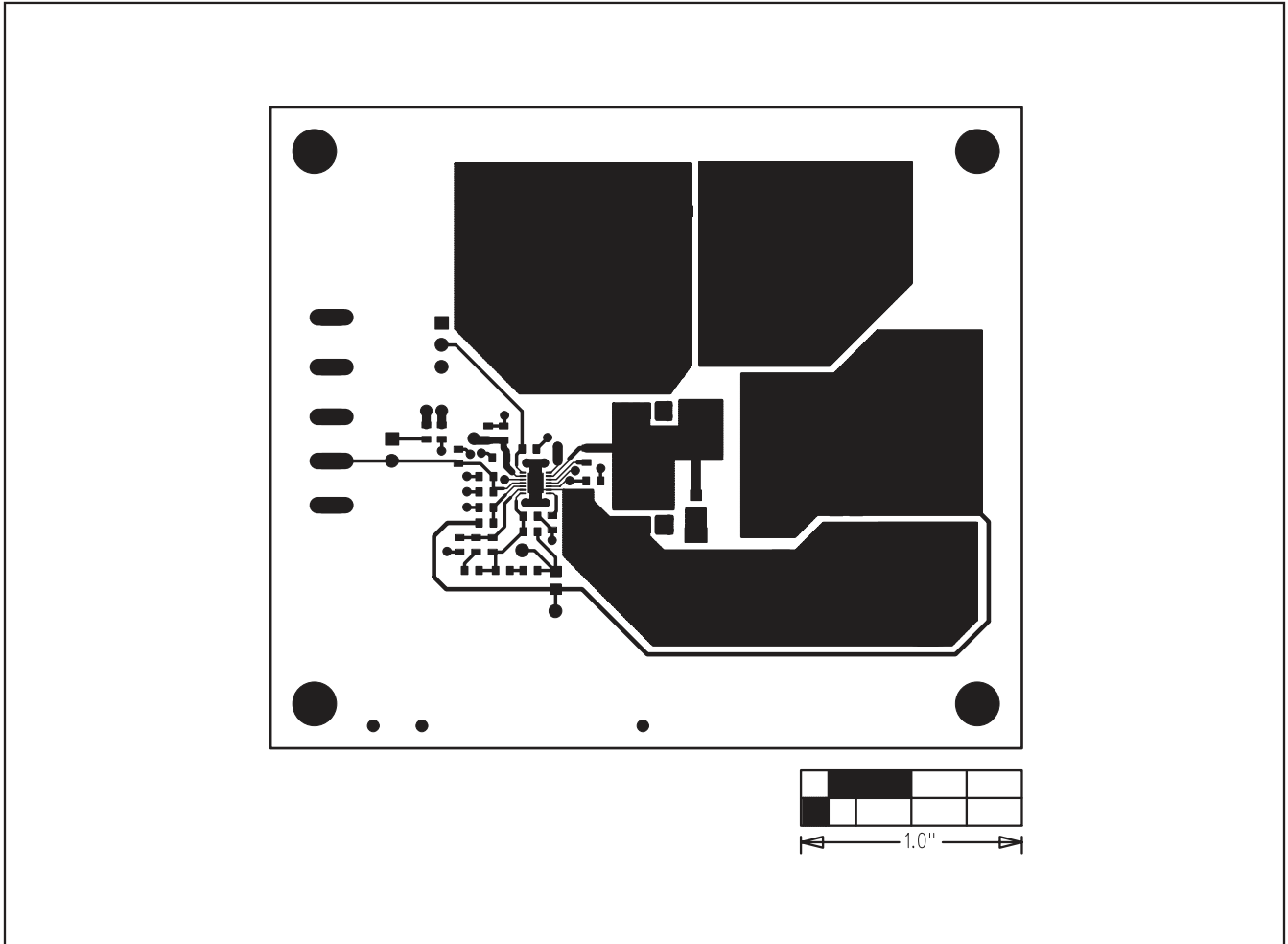

Figure 3. MAX15026B EV Kit PCB Layout—Component Side

MAX15026B Evaluation Kit

Evaluates: MAX15026B

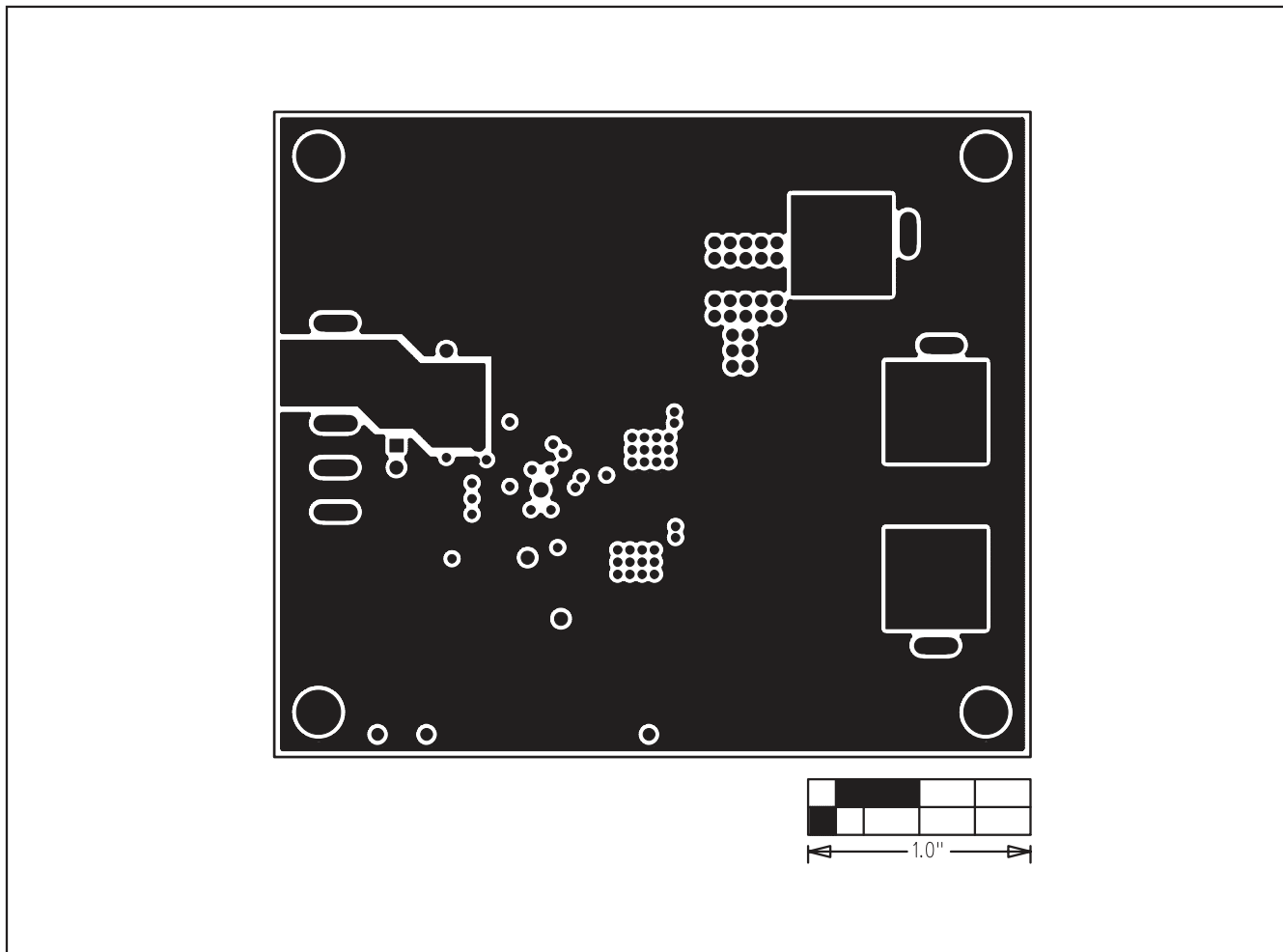

Figure 4. MAX15026B EV Kit PCB Layout—Power Layer 2

MAX15026B Evaluation Kit

Evaluates: MAX15026B

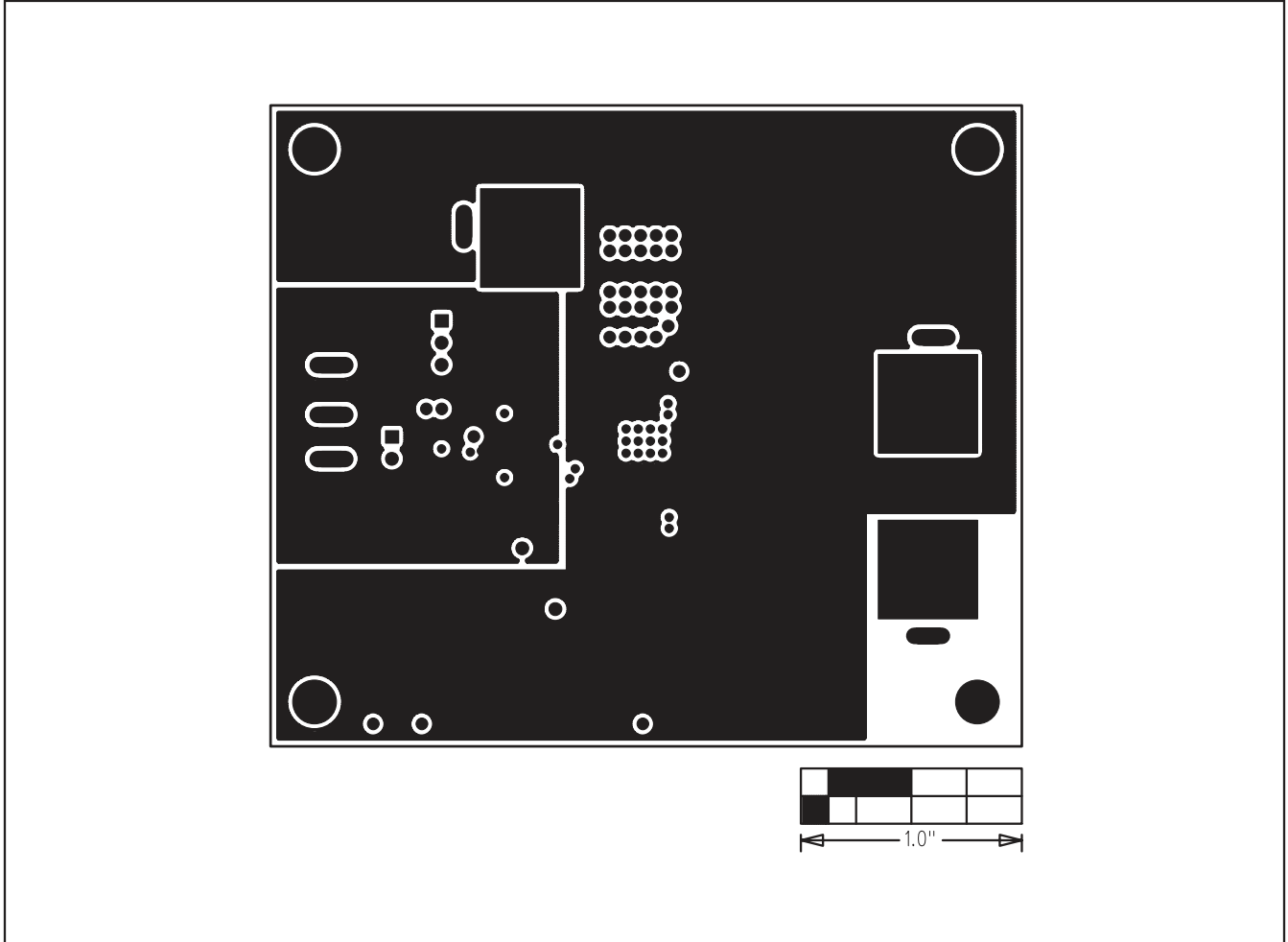

Figure 5. MAX15026B EV Kit PCB Layout—GND Layer 3

MAX15026B Evaluation Kit

Evaluates: MAX15026B

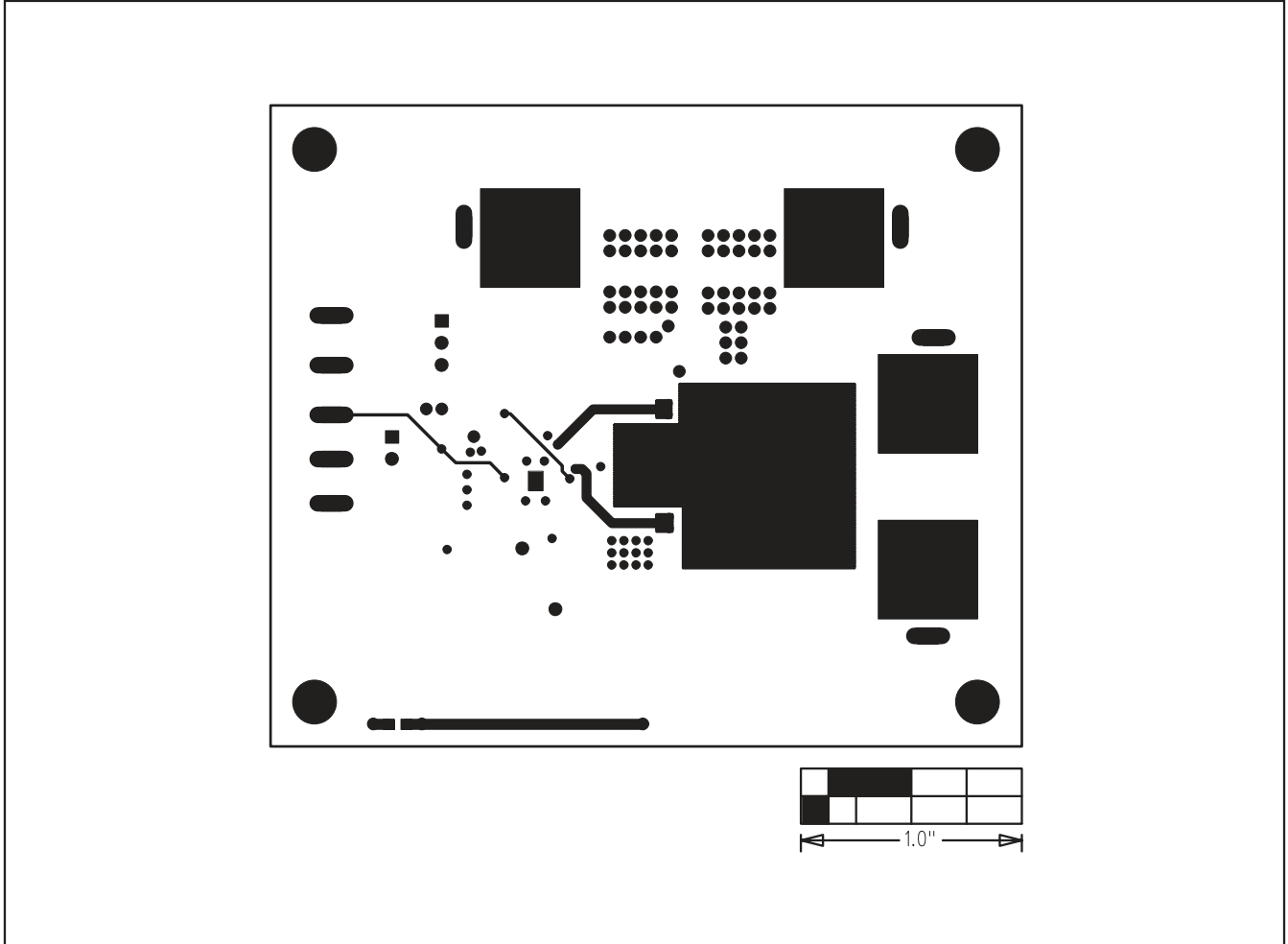

Figure 6. MAX15026B EV Kit PCB Layout—Solder Side

Maxim cannot assume responsibility for use of any circuitry other than circuitry entirely embodied in a Maxim product. No circuit patent licenses are implied. Maxim reserves the right to change the circuitry and specifications without notice at any time.

10 _____ **Maxim Integrated Products, 120 San Gabriel Drive, Sunnyvale, CA 94086 408-737-7600**

© 2008 Maxim Integrated Products

MAXIM is a registered trademark of Maxim Integrated Products, Inc.