

RECOMMENDED MOUNTING HOLE PATTERN FOR 1.60 [0.063] THICK P.C. BOARD

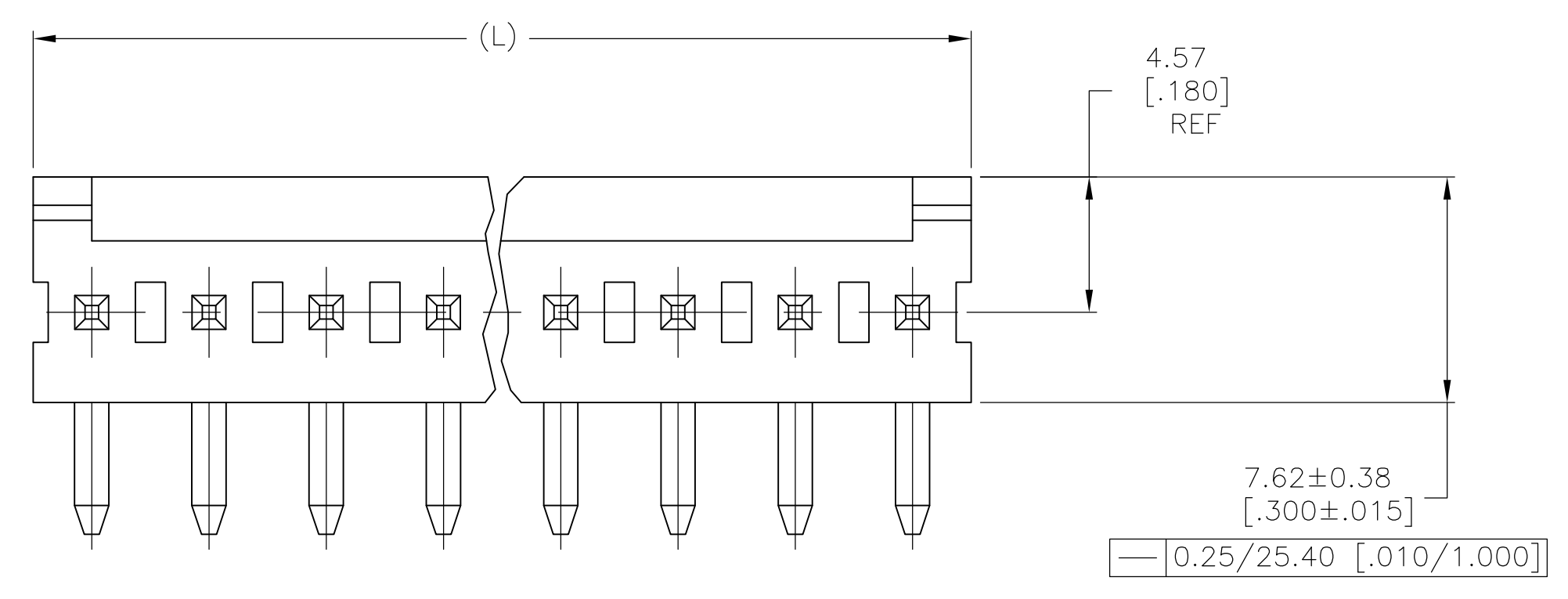

- 1 POST TO WITHSTAND 13 NEWTONS (3 LBS.) MINIMUM AXIAL FORCE IN BOTH DIRECTIONS SHOWN WITHOUT DISLODGING.
- 2 TOLERANCES APPLY TO SOLDER SIDE OF BOARD.
- 3 MEASURED AT SURFACE -A-
- 4 PLASTIC FLASH PERMITTED IN THIS AREA.
- 5 PARTS COMPLY WITH AMP SOLDERABILITY SPEC. NO. 109-11-2.
- 6 ONE HOLE MAY BE UNDERSIZED 1.65/1.52 [0.065/0.060] DIA. FOR ASSEMBLY RETENTION DURING WAVE SOLDERING.
- 7 MATERIAL: HEADER-THERMOPLASTIC POLYESTER GLASS-FILLED 94V-0 (NATURAL) POST-COPPER ALLOY (SEE NOTES 13 & 14 FOR PLATING)
- 8 COORDINATE DIMENSION APPLIES FROM CENTER OF ACTUAL FEATURE.
- 9 PLASTIC BURRS CAUSED BY CUT-OFF TOOLING ARE PERMITTED WITHIN THE MAXIMUM TOLERANCE ENVELOPE
- 10 POST TO BE MEASURED WHEN STRIP IS HELD FLAT.
- 11 POST MUST WITHSTAND TWO 90° BENDS AGAINST EXTRUSION WITHOUT BREAKING.
- 12 DIMENSION SHOULD BE 8.26-10.16 [0.325-.400] MIN WHEN MATING WITH A MTA-156 CONNECTOR ASSEMBLY OR 8.26-8.76 [0.325-.345] WHEN MATING WITH A SL-156 CONNECTOR ASSEMBLY.
- 13 PLATING: GOLD PLATE AREA, 0.00038 [0.000015] GOLD OR 0.00008 [0.000003] MIN GOLD FLASH OVER 0.00030 [0.000012] PALLADIUM NICKEL, PER CONNECTIVITY'S DISCRETION, ALL SIDES, OVER NICKEL UNDERPLATE, 0.00127 [0.000050] MIN, ALL SIDES AND ENTIRE LENGTH OF POST.
- 14 PLATING: BRIGHT TIN/LEAD (93/7) PLATE AREA, 0.00381-0.00889 [0.000150-.000350] THICK, ALL FOUR SIDES 3.18 [0.125] MINIMUM FOR -2 THRU -24. MATTE TIN PLATE AREA 0.00381-0.00889 [0.000150-.000350] THICK ALL FOUR SIDES, 3.18 [0.125] FOR -32 THRU -54.
- 15 OBSOLETE PARTS: OBSOLETE CIS STREAMLINING PER D.RENAUD/D.SINISI
- 16 OBSOLETE PART

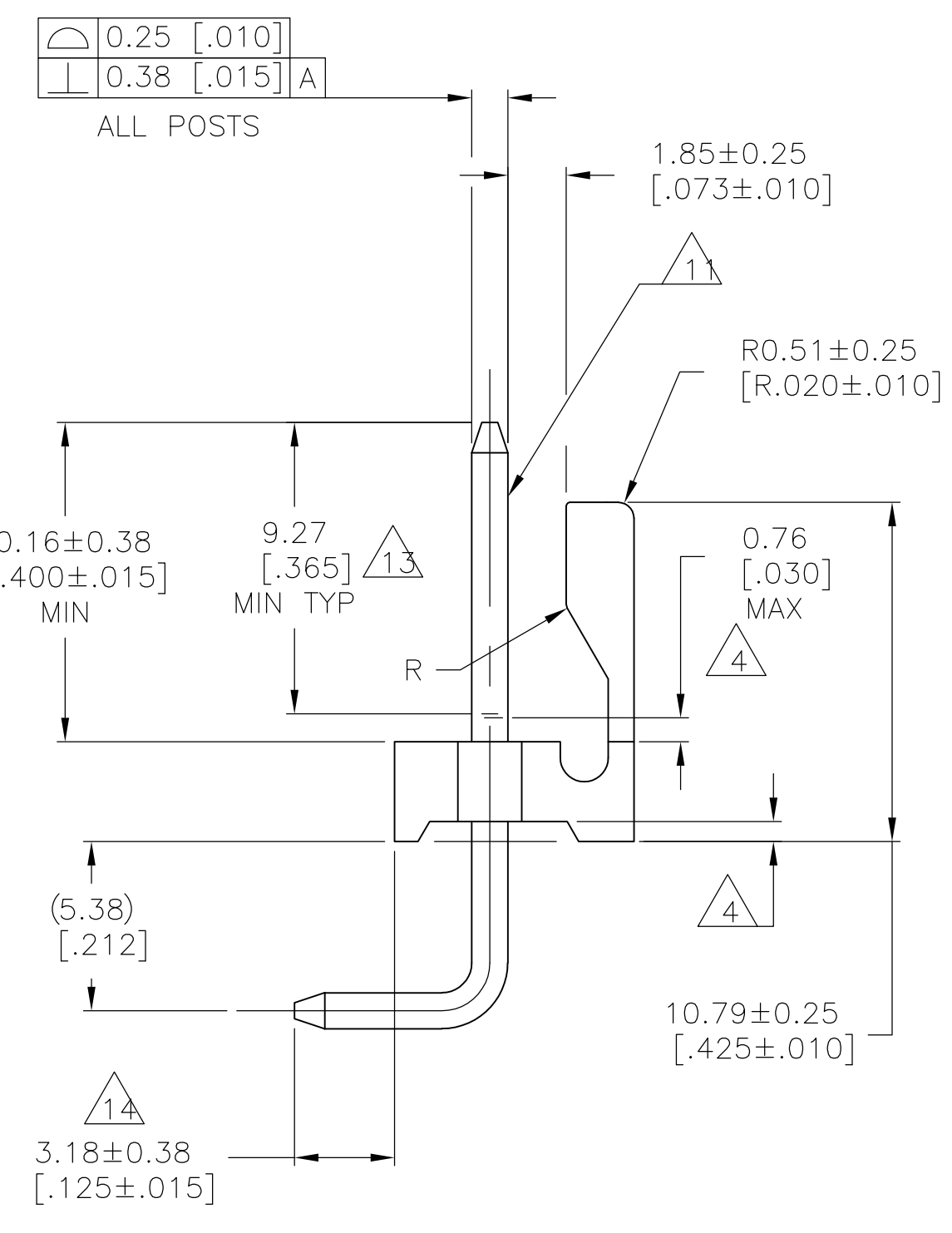
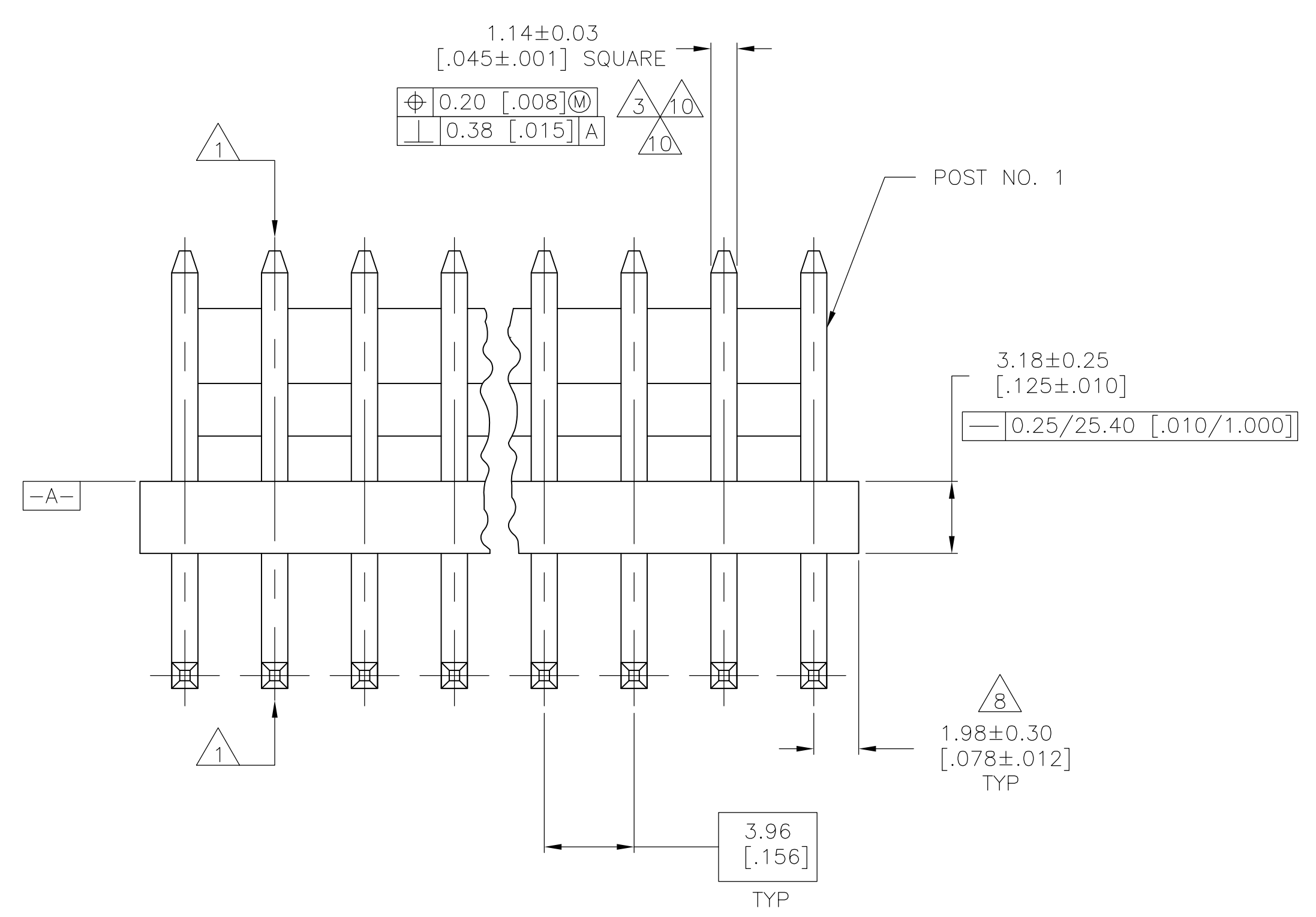

DIM (L)	NO.OF POSN	ASSEMBLY
95.10 [3.744]	24	5-641121-4
91.14 [3.588]	23	5-641121-3
87.17 [3.432]	22	5-641121-2
83.21 [3.276]	21	5-641121-1
79.25 [3.120]	20	5-641121-0
75.29 [2.964]	19	4-641121-9
71.32 [2.808]	18	4-641121-8
67.36 [2.652]	17	4-641121-7
63.40 [2.496]	16	4-641121-6
59.44 [2.340]	15	4-641121-5
55.47 [2.184]	14	4-641121-4
51.51 [2.028]	13	4-641121-3
47.55 [1.872]	12	4-641121-2
43.59 [1.716]	11	4-641121-1
39.62 [1.560]	10	4-641121-0
35.66 [1.404]	9	3-641121-9
31.70 [1.248]	8	3-641121-8
27.74 [1.092]	7	3-641121-7
23.77 [0.936]	6	3-641121-6
19.81 [0.780]	5	3-641121-5
15.85 [0.624]	4	3-641121-4
11.89 [0.468]	3	3-641121-3
7.92 [0.312]	2	3-641121-2

DIM (L)	NO.OF POSN	ASSEMBLY
95.10 [3.744]	24	2-641121-4
91.14 [3.588]	23	2-641121-3
87.17 [3.432]	22	2-641121-2
83.21 [3.276]	21	2-641121-1
79.25 [3.120]	20	2-641121-0
75.29 [2.964]	19	1-641121-9
71.32 [2.808]	18	1-641121-8
67.36 [2.652]	17	1-641121-7
63.40 [2.496]	16	1-641121-6
59.44 [2.340]	15	1-641121-5
55.47 [2.184]	14	1-641121-4
51.51 [2.028]	13	1-641121-3
47.55 [1.872]	12	1-641121-2
43.59 [1.716]	11	1-641121-1
39.62 [1.560]	10	1-641121-0
35.66 [1.404]	9	641121-9
31.70 [1.248]	8	641121-8
27.74 [1.092]	7	641121-7
23.77 [0.936]	6	641121-6
19.81 [0.780]	5	641121-5
15.85 [0.624]	4	641121-4
11.89 [0.468]	3	641121-3
7.92 [0.312]	2	641121-2

THIS DRAWING IS A CONTROLLED DOCUMENT.

DIMENSIONS: mm [INCHES]	TOLERANCES UNLESS OTHERWISE SPECIFIED:	DIN S. HOOVER 07NOV02	TE Connectivity
0 PLC ± -	1 PLC ± -	APVD D. ROSSI 07NOV02	NAME MTA-156 HEADER ASSEMBLY, FRICTION LOCK RIGHT ANGLE, FRONT BEND, .045 SQUARE POST .000015 GOLD
2 PLC ± -	3 PLC ± 0.13 [0.005]	SIZE A1	CAGE CODE DRAWING NO. 00779
4 PLC ± -	ANGLES ± -	WEIGHT -	SCALE 5:1 SHEET 1 OF 1 REV A1
MATERIAL	FINISH	CUSTOMER DRAWING	RESTRICTED TO