

## KW30 Series

# 1mm Pitch, Single Row, Center Lock, Wire-to-Board Connector (UL/C-UL Listed)



Positive-Lock



P= 1.0mm



Wide Variation



NEW

## Features

### 1. Wide Variations

- 1mm Pitch (2pos. is 2mm pitch)
- Single Row, 2-15pos.
- Center Lock Type
- Interface Types: Straight / Right Angle
- 28-32 AWG
- Gold plated

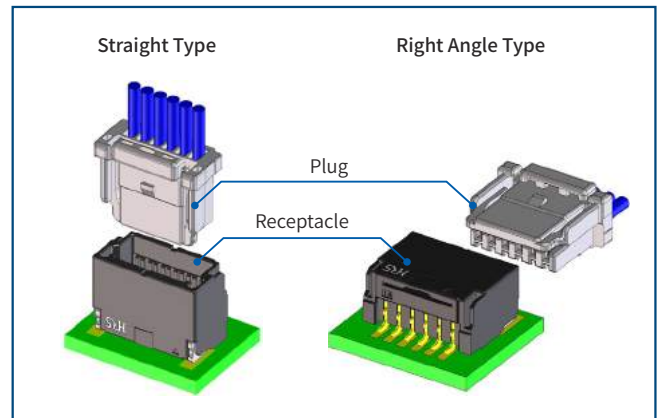

Mated Combination

### 2. High Contact Reliability

The 2-point contact and clipping design of the receptacle female contact ensures contact stability. The plug crimp contact has a box shape that does not easily get caught or deformed. In addition, the deflection prevention design of the crimp contact distributes stress from the female contact and enhance contact reliability.

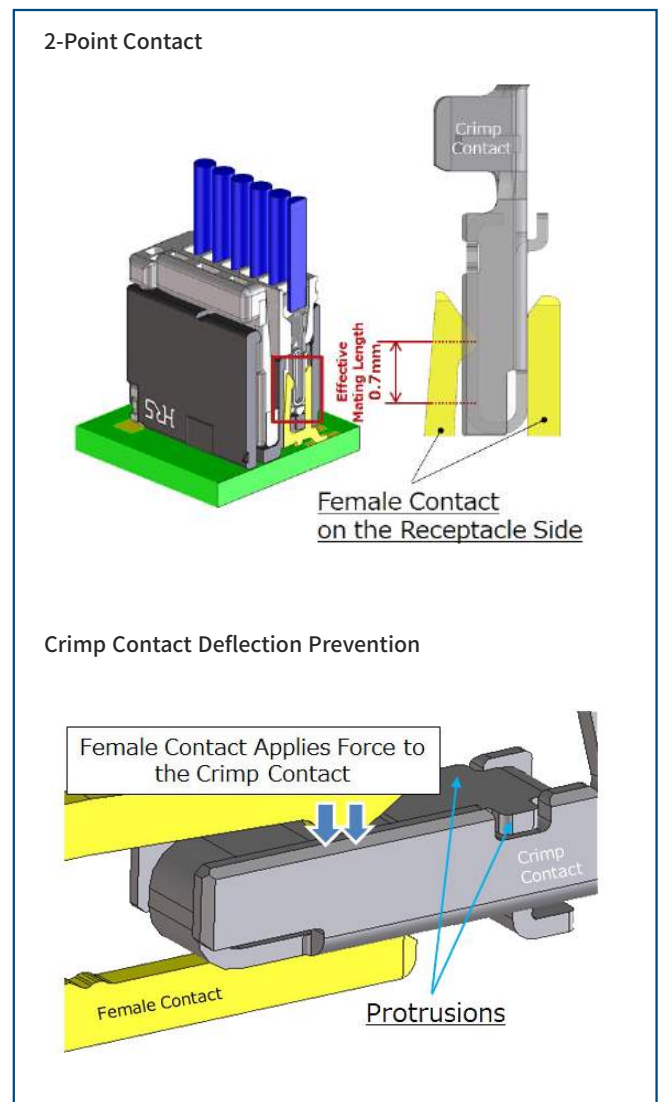

### 3. High Vibration Resistance

The rib design provides a secure fit when mating the plug and receptacle for high vibration resistance. The KW30 Series clears the 2,000Hz vibration test and is suitable for applications that require high reliability under vibration.

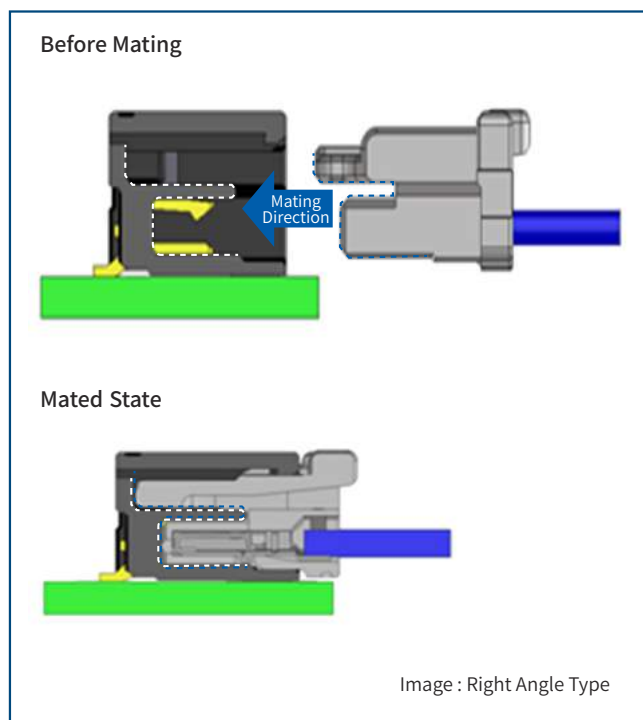

Prevents rattling between the plug and receptacle

### 4. Safety design prevents incomplete mating, mis-insertion and lock damage

### 5. Halogen-free

No chlorine or bromine exceeding the standard value is used in the connector.

\*As defined by IEC 61249-2-21

Br : 900ppm max., Cl : 900ppm max.,

Br+Cl : 1500ppm max.

### 6. UL/C-UL Compliant

## Product Specifications

Rated Current (Note 1)	No. of Pos.	28 AWG	30 AWG	32AWG	Operating Temperature (Note 2)	-55 to +105°C
	2 (2mm Pitch)	3A	1A	0.8A		
	3-15	1A			Operating Humidity Range (Note 3)	20 to 80%
Rated Voltage	100V AC/DC				Storage Temperature Range (Note 4)	-10 to +60°C
					Storage Humidity Range (Note 3) (Note 4)	40 to 70%

UL/C-UL Safety Standard Approved Specification	Rated Current (Note 1)	28 AWG	30 AWG	32AWG
		1A	1A	0.8A
	Rated Voltage	100V AC/DC		

UL/C-UL File No. and Recognition No. E132750

Items	Specifications	Conditions
Insulation Resistance	100MΩ Min.	Measured at 250V DC
Withstanding Voltage	No flashover or insulation breakdown	500V AC for 1 min.
Contact Resistance	30mΩ Max.	Measured at 10mA, 20mV AC
Mating Durability	Contact Resistance : 50mΩ Max.	30 times
Vibration Resistance	No electrical discontinuity of 1μs or more Contact Resistance : 50mΩ Max.	Frequency 10 to 55Hz, single amplitude 1.52mm, at 2 hours for 3 directions
Shock Resistance	No electrical discontinuity of 1μs or more Contact Resistance : 50mΩ Max.	Accelerated velocity : 490 m/s <sup>2</sup> for 11ms, half-sine wave in 3 directions, 3 times for each direction
Moisture Resistance (Steady State)	Contact Resistance : 50mΩ Max. Insulation Resistance : 100MΩ Min.	Left for 240 hours at temperature of 40±2°C and humidity of 90 to 95%
Temperature Cycles	Contact Resistance : 50mΩ Max. Insulation Resistance : 100MΩ Min.	Temperature : -55 → +105°C Time : 30 → 30 min. for 25 cycles
Soldering Heat Resistance	No deformation of the insulator parts affecting performance.	Reflow : See the recommended temperature profile

Note 1 : This is the maximum current rating when all pins are powered or used as all power lines.

When isolating power lines into multiple circuits, current ratings may go above the stated current ratings. Please consult Hirose for details before doing this.

Note 2 : Includes temperature rise due to current flow.

Note 3 : Use without condensation on parts.

Note 4 : Storage refers to long-term storage of unused items before they are mounted on the PCB.

Operating temperature and humidity range apply when the product is not powered after PCB mounting and when temporarily stored during transportation.

## Materials / Finish

Product	Component	Material	Color / Finish	Remarks
Receptacle	Insulator	LCP	Black	UL94V-0
	Contact	Copper Alloy	Gold Plated	-
	Retention Tab	Phosphor Bronze	Tin Plated	-
Plug	Insulator	PA66	Black	UL94V-0
Crimp Contact	Contact	Copper Alloy	Gold Plated	-

## Product Number Structure

Refer to the chart below when determining the product specifications from the product number.  
Please select from the product numbers listed in this catalog when placing orders.

### Connector

**KW30** - **6** **S** - **1** **V** **(800)**

①                      ②      ③                      ④      ⑤                      ⑥

### Crimp Contact

**KW30** - **2830** **PCF** **A** **(800)**

①                      ②                      ③                      ④                      ⑤

① Series Name	KW30	⑥ Applicable Wire Size	2830 : 28-30 AWG 3032 : 30-32 AWG
② No. of Pos.	Single Row : 2-15pos.	⑦ Packaging Method/Type	PCF : Plug Contact, Reel
③ Connector Type	P : Plug S : Receptacle	⑧ Plating Specifications	A : Gold Plated
④ Contact Pitch	1 : 1mm (3-15pos.) 2 : 2mm (2pos. Only Due to Removal of Middle Pin)	⑨ Specifications	800 : Standard
⑤ Terminal Type	H : Right Angle SMT V : Straight SMT C : Plug Socket		

## Straight Receptacle

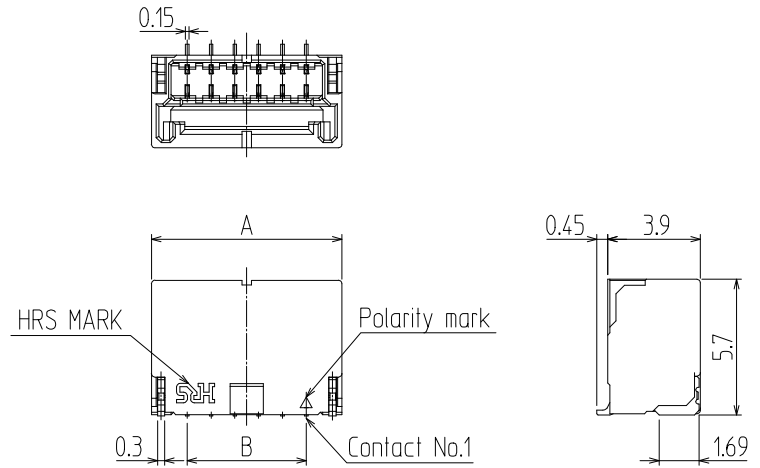

### Recommended PCB Layout (t=1.6mm)

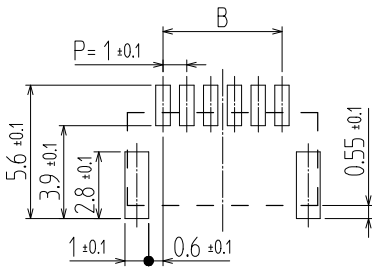

Unit : mm

Part No.	HRS No.	No. of Pos.	A	B	Purchase Unit
KW30-2S-2V(800)	CL0480-0833-0-00	2	5.0	2.0	800pcs per reel
KW30-3S-1V(800)	CL0480-0834-0-00	3	5.0	2.0	
KW30-4S-1V(800)	Under Planning (Note)	4	6.0	3.0	
KW30-5S-1V(800)	Under Planning (Note)	5	7.0	4.0	
KW30-6S-1V(800)	CL0480-0835-0-00	6	8.0	5.0	
KW30-7S-1V(800)	Under Planning (Note)	7	9.0	6.0	
KW30-8S-1V(800)	CL0480-0836-0-00	8	10.0	7.0	
KW30-9S-1V(800)	Under Planning (Note)	9	11.0	8.0	
KW30-10S-1V(800)	CL0480-0837-0-00	10	12.0	9.0	
KW30-11S-1V(800)	Under Planning (Note)	11	13.0	10.0	
KW30-12S-1V(800)	Under Planning (Note)	12	14.0	11.0	
KW30-13S-1V(800)	Under Planning (Note)	13	15.0	12.0	
KW30-14S-1V(800)	Under Planning (Note)	14	16.0	13.0	
KW30-15S-1V(800)	CL0480-0838-0-00	15	17.0	14.0	

Note : Products without HRS No. are currently being planned for development. Please contact a Hirose representative regarding questions on pin count variation development.

## Right Angle Receptacle

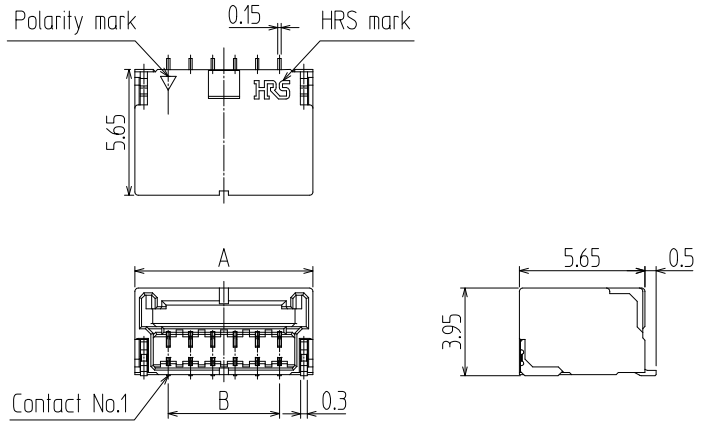

### Recommended PCB Layout (t=1.6mm)

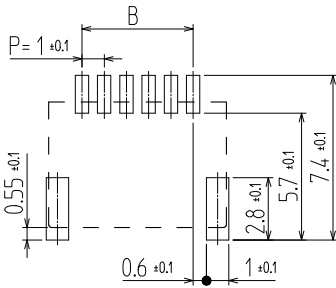

Unit : mm

Part No.	HRS No.	No. of Pos.	A	B	Purchase Unit
KW30-2S-2H(800)	CL0480-0828-0-00	2	5.0	2.0	1500pcs per reel
KW30-3S-1H(800)	CL0480-0829-0-00	3	5.0	2.0	
KW30-4S-1H(800)	Under Planning (Note)	4	6.0	3.0	
KW30-5S-1H(800)	Under Planning (Note)	5	7.0	4.0	
KW30-6S-1H(800)	CL0480-0767-0-00	6	8.0	5.0	
KW30-7S-1H(800)	Under Planning (Note)	7	9.0	6.0	
KW30-8S-1H(800)	CL0480-0830-0-00	8	10.0	7.0	
KW30-9S-1H(800)	Under Planning (Note)	9	11.0	8.0	
KW30-10S-1H(800)	CL0480-0831-0-00	10	12.0	9.0	
KW30-11S-1H(800)	Under Planning (Note)	11	13.0	10.0	
KW30-12S-1H(800)	Under Planning (Note)	12	14.0	11.0	
KW30-13S-1H(800)	Under Planning (Note)	13	15.0	12.0	
KW30-14S-1H(800)	Under Planning (Note)	14	16.0	13.0	
KW30-15S-1H(800)	CL0480-0832-0-00	15	17.0	14.0	

Note : Products without HRS No. are currently being planned for development. Please contact a Hirose representative regarding questions on pin count variation development.

## Plug



Shown with crimp contact inserted.

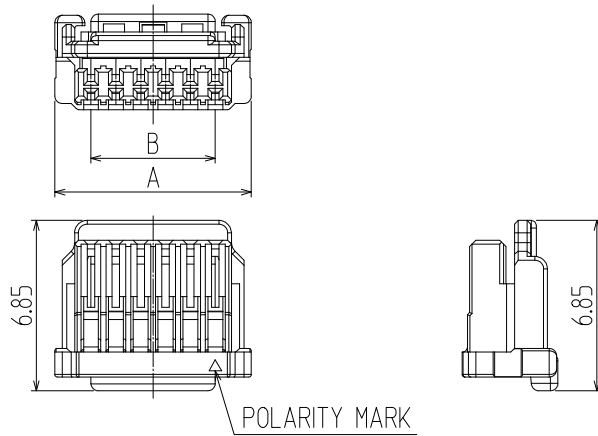

Unit : mm

Part No.	HRS No.	No. of Pos.	A	B	Purchase Unit
KW30-2P-2C(800)	CL0480-0839-0-00	2	4.9	2.0	1000pcs per bag
KW30-3P-1C(800)	CL0480-0840-0-00	3	4.9	2.0	
KW30-4P-1C(800)	Under Planning (Note)	4	5.9	3.0	
KW30-5P-1C(800)	Under Planning (Note)	5	6.9	4.0	
KW30-6P-1C(800)	CL0480-0768-0-00	6	7.9	5.0	
KW30-7P-1C(800)	Under Planning (Note)	7	8.9	6.0	
KW30-8P-1C(800)	CL0480-0841-0-00	8	9.9	7.0	
KW30-9P-1C(800)	Under Planning (Note)	9	10.9	8.0	
KW30-10P-1C(800)	CL0480-0842-0-00	10	11.9	9.0	
KW30-11P-1C(800)	Under Planning (Note)	11	12.9	10.0	
KW30-12P-1C(800)	Under Planning (Note)	12	13.9	11.0	
KW30-13P-1C(800)	Under Planning (Note)	13	14.9	12.0	
KW30-14P-1C(800)	Under Planning (Note)	14	15.9	13.0	
KW30-15P-1C(800)	CL0480-0843-0-00	15	16.9	14.0	

Note : Products without HRS No. are currently being planned for development. Please contact a Hirose representative regarding questions on pin count variation development.



## Crimp Contact

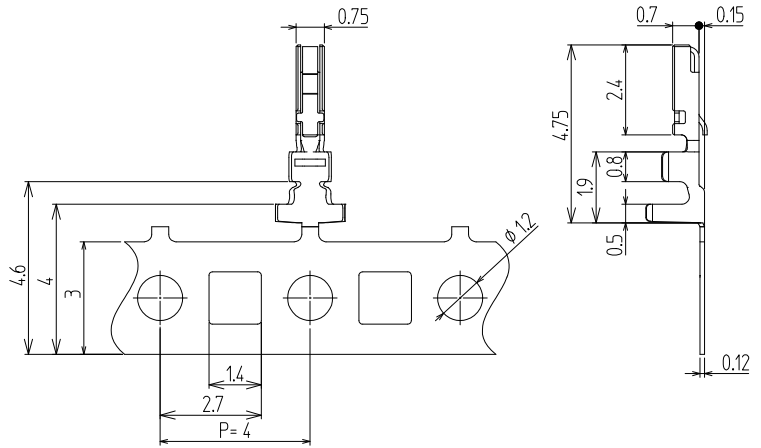
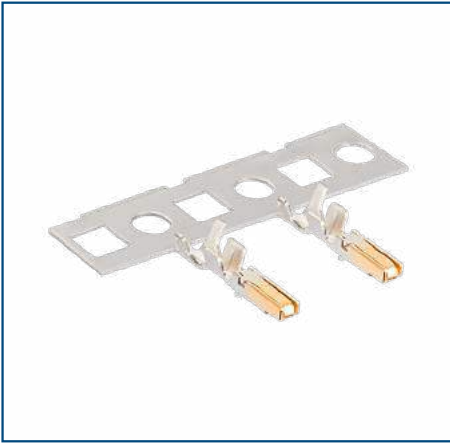

Part No.	HRS No.	Purchase Unit
KW30-2830PCFA(800)	CL0480-0844-0-00	20,000pcs per reel
KW30A-2830PCFA(800)	Under Planning (Note)	
KW30-3032PCFA(800)	CL0480-0845-0-00	

Note : Products without HRS No. are currently being planned for development. Please contact a Hirose representative regarding questions on pin count variation development.

## Applicable Wire (Tin Plated Annealed Copper Wire)

Part No.	UL	Wire Size	Stranded Wire Structure	Jacket Diameter
KW30-2830PCFA(800)	1061	28 AWG	7 / 0.127mm	Ø0.80 to 0.88mm
		30 AWG	7 / 0.102mm	
KW30A-2830PCFA(800)	1571	28 AWG	7 / 0.127mm	Ø0.56 to 0.58mm
		30 AWG	7 / 0.102mm	
KW30-3032PCFA(800)	1571	30 AWG	7 / 0.102mm	Ø0.54 to 0.56mm
		32 AWG	7 / 0.080mm	

Note : When using cables not specified by Hirose, please contact a Hirose sales representative.

## Mated Dimensions Diagram

### Straight Receptacle to Plug Connection

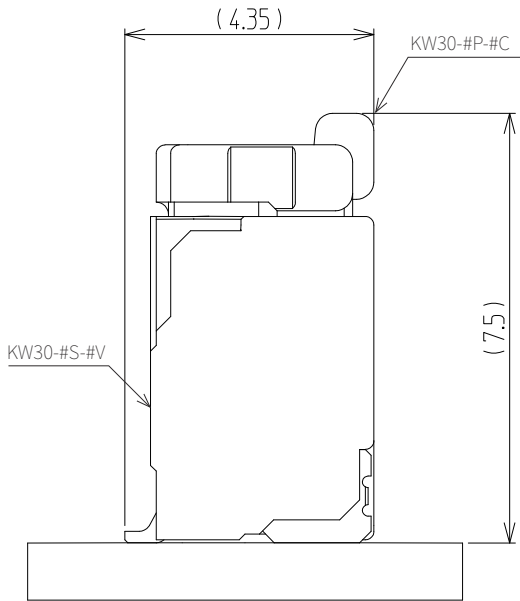

### Right Angle Receptacle to Plug Connection

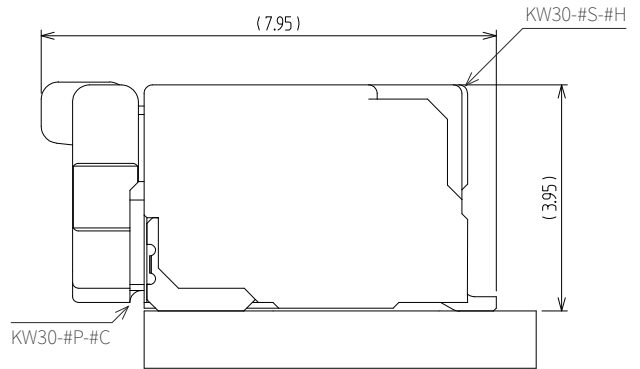

## Applicable Tools

Type	Part No.	HRS No.	Applicable Contacts
Applicator	AP105-KW30-2830P	CL0901-7002-0-00	KW30-2830PCFA(800)
	AP105-KW30A-2830PCFA	Under Planning (Note 1)	KW30A-2830PCFA(800)
	AP105-KW30-3032PCFA	Under Planning (Note 1)	KW30-3032PCFA(800)
Automatic Crimp Press	CM-105C	CL0901-0001-0-00	-
Hand Tool	HT307/KW30-2830PA (Note 4)	Under Planning (Note 1)	KW30-2830PCFA(800)
	HT307/KW30A-2830PA (Note 5)	Under Planning (Note 1)	KW30A-2830PCFA(800)
	HT307/KW30-3032PA (Note 6)	Under Planning (Note 1)	KW30-3032PCFA(800)

Note 1 : Products without HRS No. are currently being planned for development. Please contact a Hirose representative regarding questions on development.

Note 2 : Please conduct crimping work according to the Crimp Quality Standard and the Crimp Condition Table.

Note 3 : Any problems that occur from using tools other than those specified by Hirose are not covered by the warranty.

Note 4 : The compatible wires are limited to UL1061, 28-30 AWG.

Note 5 : The compatible wires are limited to UL1571, 28-30 AWG.

Note 6 : The compatible wires are limited to UL1571, 30-32 AWG.

## Crimping Precautions

### ■ Items Required Prior to Crimping

The work-related documents shown below are required before starting the cable assembly.

(The ● mark represents required documents.)

Please contact a Hirose representative if you do not have these documents.

Document Title	Description	Automatic Crimping Machine	Hand Crimping Tool	Remarks
① Main Unit of Crimping Machine Instruction Manual	Explanation for main press machine unit	●	-	Bundled with the purchase of the main press machine unit.
② Applicator Instruction Manual	Crimping work method	●	-	Bundled with the purchase of applicator.
③ Applicator Spare Parts Identification	Explanation for applicator installation	●	-	
④ Crimp Conditions	Standard values of : Crimp height Tensile strength	●	-	
⑤ Crimp Quality Standards	Various standards for crimping conditions	●	-	
⑥ Hand Tool Operating Instructions	Crimping work method	-	●	Bundled with the purchase of hand tool.
⑦ Cable Assembly Procedures	Cable assembly	●	●	Contact a Hirose representative.

### ■ Tools

- Use tools designated by Hirose when crimping.
- Crimping performed using tools other than those specified is outside the scope of warranty.
- The operating instructions are available for the crimping machine and the applicator.  
Be sure to carefully read the operating instructions manual before beginning work.

### ■ Applicable Cables

Check that the cables to be used are within the applicable range.

If you intend to use a cable other than those recommended, contact a Hirose representative.

#### 【Precautions】

- Cables applicable to crimp connectors are tin-plated, soft copper stranded wires.
- Avoid crimping solid wire, wires with polyester threads or tin coated wires.
- Avoid crimping two cables together.
- The crimp height setting values (Note) may vary depending on the difference in the core wire configuration even if the computed cross-sectional area is the same.

Note : The crimp height is an important item that determines crimping quality. We execute crimping tests for each electric wire to ensure the optimal value for the crimp height with high precision, thereby ensuring optimal setup values.

Hirose conducts crimp testing on each wire in order to set the optimum crimp height accurately.

## Operating Environment

Please contact a Hirose representative if you are designing this connector into environmental conditions where high and low temperatures are repeated.

## Usage Precautions

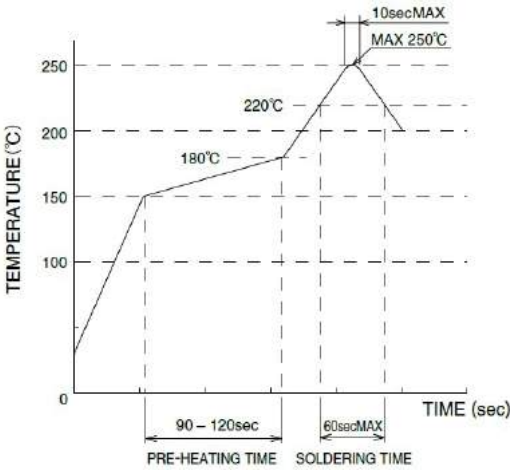
Recommended Temperature Profile	 <p>[Conditions]</p> <ol style="list-style-type: none"> <li>1. Peak temperature : 250°C Max. for 10 sec. Max.</li> <li>2. Heating : 220°C Min. for 60 sec. Max.</li> <li>3. Preheating : 150 to 180°C, 90 to 120 sec.</li> <li>4. Number of Reflow Cycles : 2 cycles Max.</li> </ol> <p>*Measurement is conducted at the contact lead part. Soldering results may change depending on conditions such as solder paste type, manufacturer, PCB size, and other soldering materials. Please determine all mounting conditions before use.</p> <p>*This temperature profile is a recommended value.</p>
Recommended Manual Soldering Conditions	Soldering iron temperature : $350 \pm 10^{\circ}\text{C}$ , Soldering time : within 5 seconds
Recommended Metal Mask Thickness and Aperture Ratio (PCB Pattern Area Ratio)	Thickness : 0.1mm, Aperture Ratio : 100%
Warpage of the Board	A maximum of 0.02mm at the center of connector, as measured from either end of the connector
Cleaning Conditions	IPA cleaning is allowed. (Cleaning is not recommended due to potential changes in mating action and other variables. Please contact Hirose if you use other cleaning agents.)
Precautions	<ol style="list-style-type: none"> <li>1. Excessive pull force during unmating may damage the connector. If it is difficult to remove, push in lightly once and then release the lock.</li> <li>2. Always make sure to turn off the power before reinserting the connector.</li> <li>3. Do not directly touch the terminal when electricity is flowing since it is extremely dangerous.</li> <li>4. Contact a Hirose representative for cable assembly procedures or handling manuals.</li> </ol>

## While Taking into Consideration

Specifications mentioned in this catalog are reference values.

When considering to order or use this product, please confirm the Drawing and Product Specifications sheets.

Use an appropriate cable when using the connector in combination with cables.

If considering usage of a non-specified cable, please contact your sales representative.

If assembly process is done by jigs & tools which are not identified by Hirose, assurance will not be given.

If considering usage for below mentioned applications, please contact your sales representative.

In cases where the application will demand a high level of reliability, such as automotive, medical instruments, public infrastructure, aerospace/ defense etc. Hirose must review before assurance of reliability can be given.