

EVAL-M1-05F310R user guide

Modular application design kit (MADK) of IRSM005-301MH

About this document

Scope and purpose

This user guide provides an overview of the evaluation board EVAL-M1-05F310R including its main features, key data, pin assignments and mechanical dimensions.

EVAL-M1-05F310R is a power evaluation board from the modular application design kit including M1 connector, which is the iMOTION™ standard interface, and three CIPOS™ Nano 100 V half-bridge modules for motor drive applications. In combination with either EVAL-M1-101T or other control boards with M1 connector compatible, it features and demonstrates Infineon's CIPOS™ Nano IPM technology for motor drives.

The evaluation board EVAL-M1-05F310R was developed to support customers during their first steps designing applications with IRSM005-301MH CIPOS™ Nano power modules.

Intended audience

This user guide is intended for all technical specialists who know motor control, middle- and low-power electronics converters. The board is intended to be used under laboratory conditions.

Evaluation Board

This board will be used during design in, for evaluation and measurement of characteristics, and proof of data sheet specifications.

Note: PCB and auxiliary circuits are NOT optimized for final customer design.

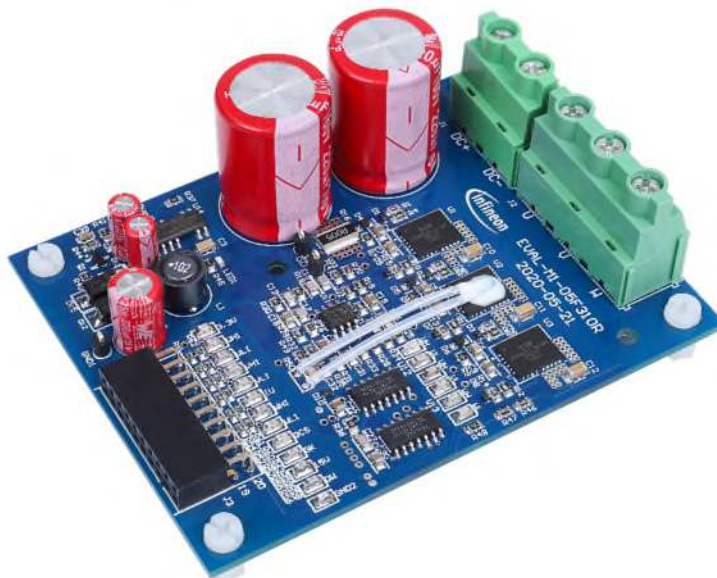

Important notice

Important notice

“Evaluation Boards and Reference Boards” shall mean products embedded on a printed circuit board (PCB) for demonstration and/or evaluation purposes, which include, without limitation, demonstration, reference and evaluation boards, kits and design (collectively referred to as “Reference Board”).

Environmental conditions have been considered in the design of the Evaluation Boards and Reference Boards provided by Infineon Technologies. The design of the Evaluation Boards and Reference Boards has been tested by Infineon Technologies only as described in this document. The design is not qualified in terms of safety requirements, manufacturing and operation over the entire operating temperature range or lifetime.

The Evaluation Boards and Reference Boards provided by Infineon Technologies are subject to functional testing only under typical load conditions. Evaluation Boards and Reference Boards are not subject to the same procedures as regular products regarding returned material analysis (RMA), process change notification (PCN) and product discontinuation (PD).

Evaluation Boards and Reference Boards are not commercialized products, and are solely intended for evaluation and testing purposes. In particular, they shall not be used for reliability testing or production. The Evaluation Boards and Reference Boards may therefore not comply with CE or similar standards (including but not limited to the EMC Directive 2004/EC/108 and the EMC Act) and may not fulfill other requirements of the country in which they are operated by the customer. The customer shall ensure that all Evaluation Boards and Reference Boards will be handled in a way which is compliant with the relevant requirements and standards of the country in which they are operated.

The Evaluation Boards and Reference Boards as well as the information provided in this document are addressed only to qualified and skilled technical staff, for laboratory usage, and shall be used and managed according to the terms and conditions set forth in this document and in other related documentation supplied with the respective Evaluation Board or Reference Board.

It is the responsibility of the customer’s technical departments to evaluate the suitability of the Evaluation Boards and Reference Boards for the intended application, and to evaluate the completeness and correctness of the information provided in this document with respect to such application.

The customer is obliged to ensure that the use of the Evaluation Boards and Reference Boards does not cause any harm to persons or third party property.

The Evaluation Boards and Reference Boards and any information in this document is provided "as is" and Infineon Technologies disclaims any warranties, express or implied, including but not limited to warranties of non-infringement of third party rights and implied warranties of fitness for any purpose, or for merchantability.

Infineon Technologies shall not be responsible for any damages resulting from the use of the Evaluation Boards and Reference Boards and/or from any information provided in this document. The customer is obliged to defend, indemnify and hold Infineon Technologies harmless from and against any claims or damages arising out of or resulting from any use thereof.

Infineon Technologies reserves the right to modify this document and/or any information provided herein at any time without further notice.

Safety precautions

Safety precautions

Note: Please note the following warnings regarding the hazards associated with development systems.

Table 1 Safety precautions

	<p>Warning: The DC link potential of this board is up to 100 V_{DC}. When measuring voltage waveforms by oscilloscope, high voltage differential probes must be used. Failure to do so may result in personal injury or death.</p>
	<p>Warning: The evaluation or reference board contains DC bus capacitors which take time to discharge after removal of the main supply. Before working on the drive system, wait five minutes for capacitors to discharge to safe voltage levels. Failure to do so may result in personal injury or death. Darkened display LEDs are not an indication that capacitors have discharged to safe voltage levels.</p>
	<p>Warning: The evaluation or reference board is connected to the grid input during testing. Hence, high-voltage differential probes must be used when measuring voltage waveforms by oscilloscope. Failure to do so may result in personal injury or death. Darkened display LEDs are not an indication that capacitors have discharged to safe voltage levels.</p>
	<p>Warning: Remove or disconnect power from the drive before you disconnect or reconnect wires, or perform maintenance work. Wait five minutes after removing power to discharge the bus capacitors. Do not attempt to service the drive until the bus capacitors have discharged to zero. Failure to do so may result in personal injury or death.</p>
	<p>Caution: The heat sink and device surfaces of the evaluation or reference board may become hot during testing. Hence, necessary precautions are required while handling the board. Failure to comply may cause injury.</p>
	<p>Caution: Only personnel familiar with the drive, power electronics and associated machinery should plan, install, commission and subsequently service the system. Failure to comply may result in personal injury and/or equipment damage.</p>
	<p>Caution: The evaluation or reference board contains parts and assemblies sensitive to electrostatic discharge (ESD). Electrostatic control precautions are required when installing, testing, servicing or repairing the assembly. Component damage may result if ESD control procedures are not followed. If you are not familiar with electrostatic control procedures, refer to the applicable ESD protection handbooks and guidelines.</p>
	<p>Caution: A drive that is incorrectly applied or installed can lead to component damage or reduction in product lifetime. Wiring or application errors such as undersizing the motor, supplying an incorrect or inadequate AC supply, or excessive ambient temperatures may result in system malfunction.</p>
	<p>Caution: The evaluation or reference board is shipped with packing materials that need to be removed prior to installation. Failure to remove all packing materials that are unnecessary for system installation may result in overheating or abnormal operating conditions.</p>

Table of contents

About this document..... 1

Important notice 2

Safety precautions..... 3

Table of contents 4

1 The board at a glance..... 5

1.1 Delivery content5

1.2 Block diagram.....5

1.3 Main features6

1.4 Board parameters and technical data6

2 System and functional description 8

2.1 Getting started with EVAL-M1-05F310R.....8

2.1.1 iMOTION™ control board8

2.1.2 iMOTION™ development tools and software9

2.1.3 MCEWizard setup overview.....9

2.1.4 MCEDesigner setup overview.....11

2.2 The current waveform form MCEDesigner13

2.3 Description of the functional blocks.....14

2.3.1 Overview of IRSM005-301MH15

2.3.2 Overview of ICE5GR4780AG16

3 System design.....18

3.1 Inverter section using CIPOS™ Nano18

3.2 DC to DC power converter.....18

3.3 DC bus voltage measurement.....19

3.4 Current sensing and amplifying.....20

3.5 Current feedback to the control board.....20

3.6 OCP, GK and IOCP setup22

3.6.1 OCP setup on EVAL-M1-05F310R22

3.6.2 PWM shutdown and GK output.....23

3.6.3 OCP setup in MCEWizard.....24

3.7 NTC thermistor characteristics and over-heating protection calculation25

3.8 Layout27

3.9 Bill of material31

3.10 Connector details31

4 System performance33

4.1 Type working waveform at DC 48 V input.....33

4.2 T_{cmaxi} vs I_{out} at different PWM frequencies34

4.3 Options35

4.3.1 Self-cooling.....35

4.3.2 Heat-sink cooling35

4.3.3 Fan cooling36

5 References and appendices37

5.1 Abbreviations and definitions.....37

5.2 References37

Revision history.....38

EVAL-M1-05F310R user guide

Modular application design kit (MADK) of IRSM005-301MH

The board at a glance

1 The board at a glance

The EVAL-M1-05F310R evaluation board is a part of the iMOTION™ MADK for motor control (iMOTION™ MADK).

The MADK platform is intended for use in various power stages with different control boards. These boards can easily be interfaced through the 20-pin iMOTION™ MADK - M1 interface connector.

This evaluation board is designed to give comprehensible solutions for the power section featuring by CIPOS™ Nano. It provides a DC input and 3-phase output for power. It contains a single shunt for current sensing and a voltage divider for DC-link voltage measurement.

The EVAL-M1-05F310R evaluation board is available from Infineon. The features of this board are described in the design feature chapter of this document (UG-2020-24), whereas the remaining paragraphs provide information to enable the customers to copy, modify and qualify the design for production according to their own specific requirements.

Environmental conditions were considered in the design of the EVAL-M1-05F310R. The design was tested as described in this document but not qualified in term of safety requirements or manufacturing and operation over the whole operating temperature range or lifetime. The boards provided by Infineon are subject to functional testing only.

1.1 Delivery content

The EVAL-M1-05F310R evaluation board is designed to provide an ease-of-use power stage based on the Infineon's CIPOS™ Nano intelligent power module (IRSM005-301MH).

The delivery includes the finished board as shown in Figure 1 and Figure 2. It provides a 3-phase AC connector, an EMI filter and soft power-up circuit, input rectifier, DC bus capacitors and 3-phase output for connecting the motor.

It also CoolSET™ based aux power supply to provide 15V and 3.3 V, a single shunt for current sensing and over-current protection, and a voltage divider for DC-link voltage measurement. The board shown here can be operated directly with the required power supply without the need for additional components.

1.2 Block diagram

The block diagram of EVAL-M1-05F310R is depicted in Figure 1.

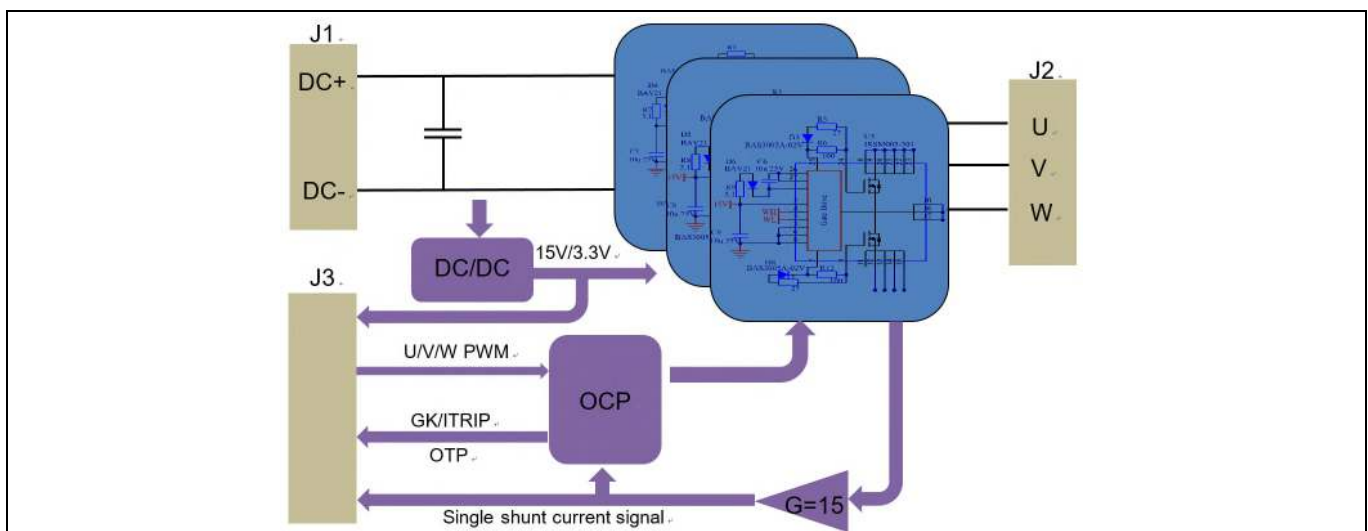

Figure 1 The block diagram of EVAL-M1-05F310R

The board at a glance

Figure 2 points out the functional groups on the top side of the EVAL-M1-05F310R design.

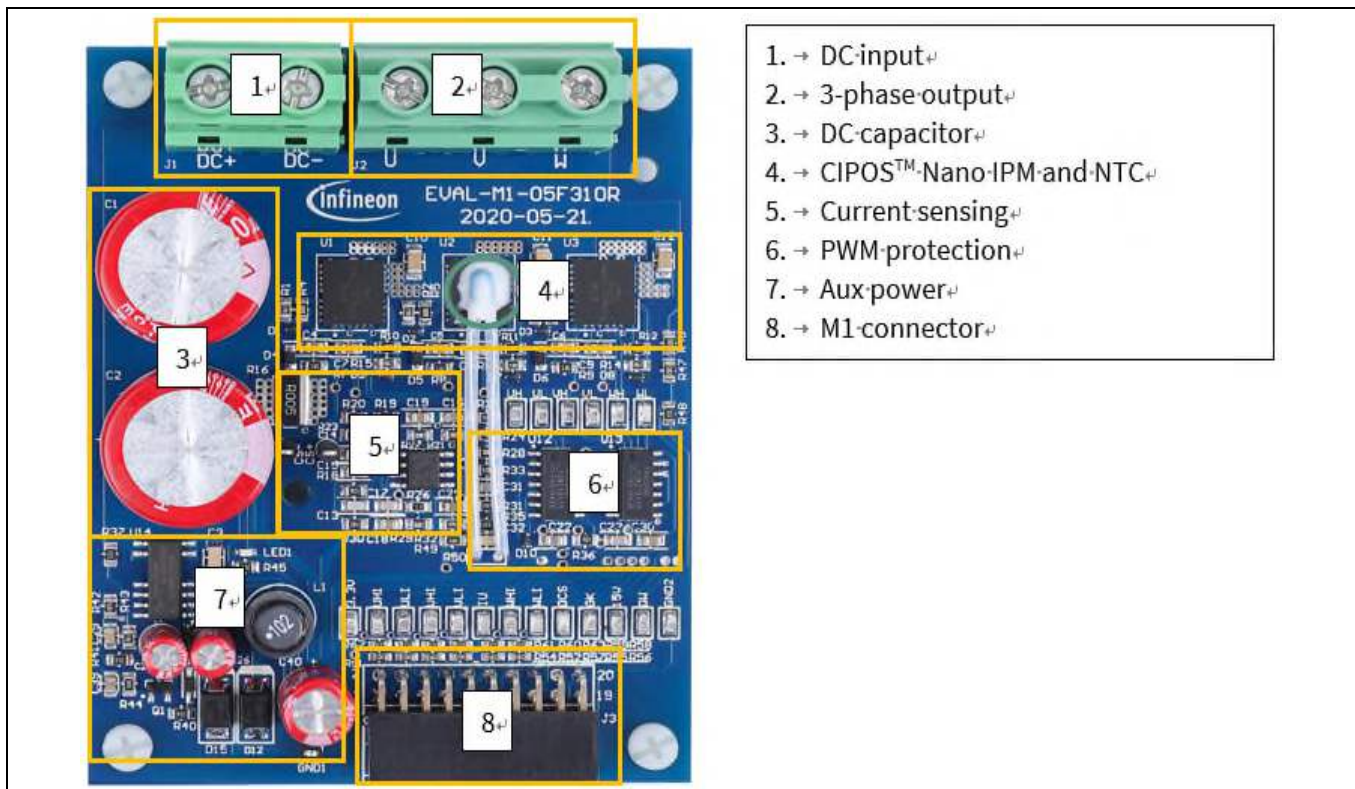

Figure 2 Functional groups of the EVAL-M1-05F310E reference design

1.3 Main features

EVAL-M1-05F310R is a complete power evaluation board including 3 half bridge IPMs for motor drive application. The kit demonstrates Infineon's IPM technology for motor drives. Main features of CIPOS™ Nano intelligent power module IRSM005-301MH include:

- MOSFET drain-to-source voltage 100 V
- Maximum DC current at 25°C case temperature $I_D = 30$ A
- Package with low thermal resistance and minimal parasitic inductance
- Independent gate driver in phase with logic input
- Gate driver supply is 15 V
- 3.3 V logic input compatible
- Undervoltage lockout protection inside the driver
- Exposed driver outputs and HEXFET gate terminals for dv/dt setting via a resistor.

1.4 Board parameters and technical data

Table 2 depicts the important specification of the evaluation board EVAL-M1-05G310R:

The board at a glance

Table 2 EVAL-M1-05F310R specifications

Parameter	Symbol	Conditions	Value	Unit
Input				
Input voltage	V_{DC}	Lower DC input, less motor power output.	30~72	V
Input current	$I_{DC(maxi)}$	Input DC48 V, output 320 W, $T_a=25^{\circ}C$.	6.7	A
Output				
Power (3-phase)	$P_{out(maxi)}$	At 48 VDC, FPWM=9 kHz, $T_a=25^{\circ}C$, $T_{case}=100^{\circ}C$ without heat sink.	320	W
Current per phase	$I_{out(maxi)}$	At 48 VDC, FPWM=9 kHz, $T_a=25^{\circ}C$, $T_{case}=100^{\circ}C$ without heat sink.	6.5	A
DC bus voltage				
Maximum DC bus voltage	$V_{DC(maxi)}$		72	V
Minimum DC bus voltage	$V_{DC(min)}$	Aux power supply's brown-in voltage.	30	V
Current feedback				
Shunt resistance	R16	Inverter current sensing resistor.	5	m Ω
Protections				
Output current trip level	I_{trip}	Level set by external comparator circuit.	27	A
Case temperature trip level	T_C	Users need to consider the temperature gap by NTC sensor, it is recommend to set at 100 $^{\circ}C$ or less.	100	$^{\circ}C$
Auxiliary power supply 15 V				
Output voltage	V_{out1}	Used for IPM.	15 \pm 5%	V
Output current	I_{out1}	Maximum output current.	100	mA
Auxiliary power supply 3.3 V				
Output voltage	V_{out2}	Used for IMC controller and protection circuits.	3.3 \pm 5%	V
Output current	I_{out2}	Maximum output current.	150	mA
PCB characteristics				
Dimension		Length \times width \times height (including PCB pillar)	91 \times 69 \times 33	mm
Material		FR4, 1.6 mm thickness, 2 oz. PCB	2 layers	
System environment				
Ambient temperature	T_a	Non-condensing, maximum RH of 75%	0~50	$^{\circ}C$

Note: For iMOTION™ IC IMCxxx, there are three types of Gatekill input source options in MCEWizard setup: Gatekill-pin, Comparator and Both. If you select “comparator” mode, the external Gatekill signal will be not used, and the signal I_Shunt will be compared by the internal comparator with the “Device over-current trigger level setting” value set in MCEWizard.

2 System and functional description

2.1 Getting started with EVAL-M1-05F310R

In order to run the motor system, a combination of the iMOTION™ MADK power board (EVAL-M1-05F310R) and the matching MADK control board (EVAL-M1-101T or other control board) are required. This chapter provides more details on setting up the system and getting started with the iMOTION™ MADK development platform.

The EVAL-M1-05F310R reference designs are tested with EVAL-M1-101T controller boards, which shipped with embedded firmware and default parameters.

Figure 3 shows the basic system connection using EVAL-M1-05F310R to run a motor with MCEDesigner.

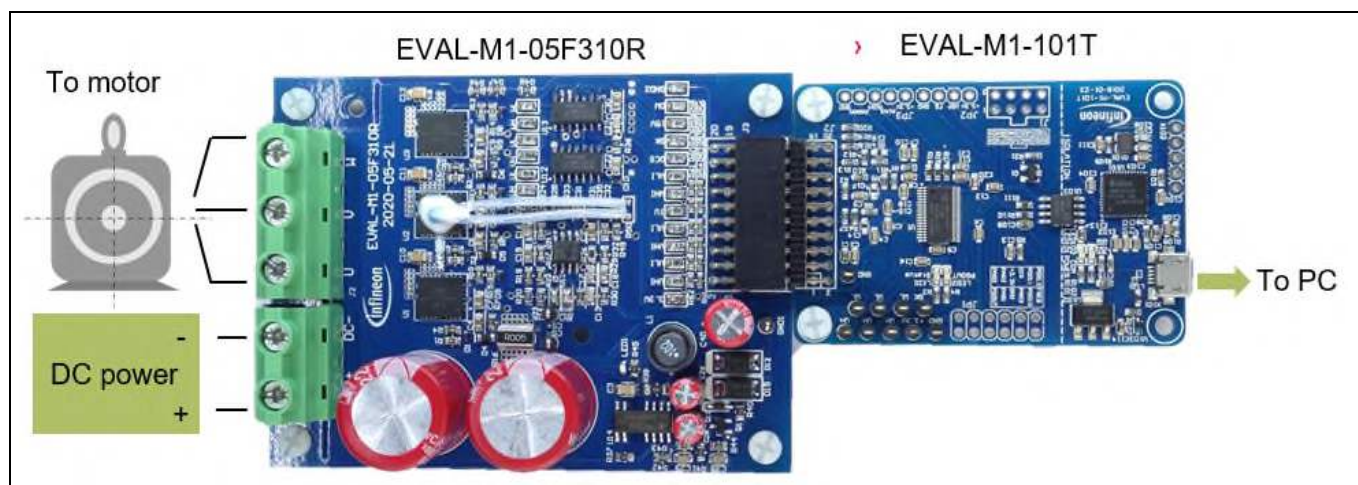

Figure 3 System connection example

2.1.1 iMOTION™ control board

1. If you want to use the Infineon control board, please go to the Infineon website, www.infineon.com/MADK, and order EVAL-M1-101T.
2. Then get the latest “IMC101T-T038 MCE Software Package” available on the website, <http://www.infineon.com/imotion-software>.
3. After you have obtained the control board and software, you are ready to connect your PC to EVAL-M1-101T via USB cable, and to program and tune the control board.
4. Connect EVAL-M1-101T’s M1 20-pin interface connector (J2) to power board (for example EVAL-M1-05F310R, see Figure 3).
5. Use MCEWizard to enter the target motor’s system and operating parameters, as well as the evaluation board’s hardware parameters, which will then be used to calculate the controller’s set digital parameters representing the complete motor drive system. First click the “Calculate” button on the “Verify & Save Page” and then save the drive parameter set into your project directory by clicking “Export to Designer file (.txt)”. The saved drive system parameter file will be later used by the MCEDesigner. Refer to Chapter 2.1.3 or MCEWizard user guide for more details.
6. Connect motor phase outputs to the motor.
7. Connect DC power to power input connector and power-on system.
8. Start MCEDesigner tool and open MCEDesigner default configuration file (.irc) for IMC101T-T038 controller (IMC101T_Vxxx.irc) by clicking “File” > “Open”. IMC101T_Vxxx.irc file is included in the “IMC101T-T038 MCE Software Package” downloaded in step 2.

System and functional description

9. MCEDesigner should automatically connect to the EVAL-M1-101T control board using default COM port (indicated by green circle next to “COMx Up” status in the bottom frame of the MCEDesigner GUI). If it cannot establish the connection, change the COM port as follows: (“System” window active) > Preferences > Connection > Connect using (select one of the other available COM ports from the drop-down menu).
10. Use the following steps to program the system parameters into the internal SRAM of iMOTION™ IC: Click “Tools” > “Programmer” and select “Program Parameters.” Browse and select the System Drive Parameters .txt file created in step 5. See Chapter 2.1.3 for more details.
11. Start the motor by clicking the green traffic light button in the control bar.
12. Stop the motor by clicking the red traffic light button in the control bar.

2.1.2 iMOTION™ development tools and software

The iMOTION™ development tool installers for MCEDesigner and MCEWizard are available for download via Infineon iMOTION™ website (<http://www.infineon.com/imotion-software>). All supported tools and software variants are listed there. Please visit this page periodically to check for tool/software updates.

The isolated on-board debugger provides the USB-to-UART bridge between the PC and the target iMOTION™ device with 1 kV DC galvanic isolation between the motor drive system (hot side) and the PC/debugger (cold) side. The on-board debugger uses the SEGGER J-Link driver for UART communication with IMC101T-T038. The J-Link driver will be installed during the MCEDesigner installation. In case the driver is not installed properly, please go to the SEGGER J-Link website to download and install the latest J-Link “Software and Documentation pack for Windows.”

2.1.3 MCEWizard setup overview

Double-click the shortcut to open the MCEWizard and configure the parameters for evaluation boards or motor. Figure 4 shows the “Welcome Page” for MCEWizard, where the MADK control board or power board can be selected from the pull-down list. Infineon continues to release new MADK controller and power boards. Therefore, it is possible that some of the latest power boards have not been pre-configured in the MCEWizard tool and cannot be selected from the pull-down menu. In that case, the user should select another power board (as similar as possible) and follow the MCEWizard setup steps by entering the parameter values that are specific to the chosen board. Make sure both “I have modified the circuit board” and “Enable advanced question” checkmarks are selected. Please refer to the Application Note of the corresponding power board for additional information.

After selecting the MADK control and the power board, start the MCEWizard system setup procedure by clicking the “Next” button in the right bottom corner as shown in Figure 4.

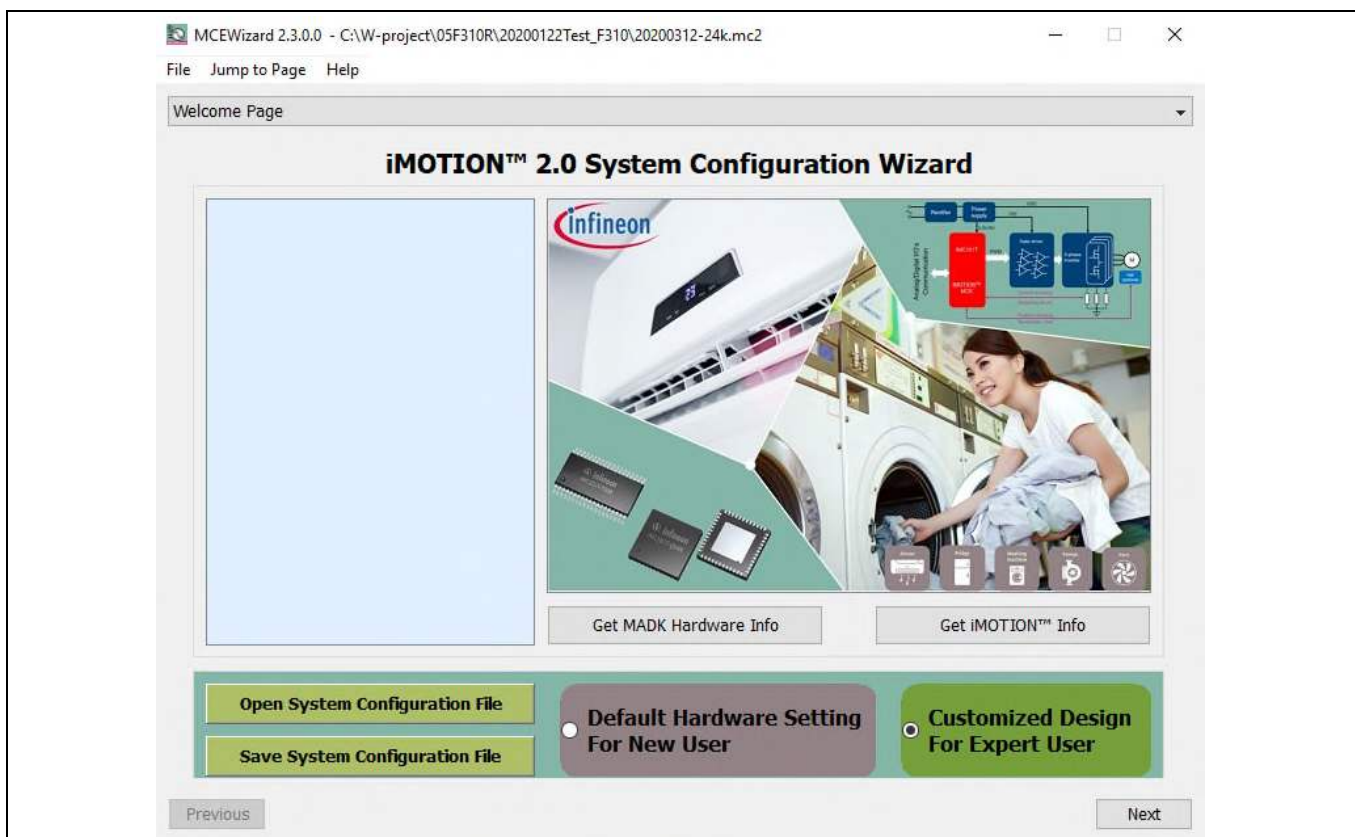

Figure 4 Welcome page of MCEWizard

The iMOTION™ MADK system enables users to easily test different combinations of control and power boards with their motors. Users should be familiar with the system level parameters that are related to the motor used. There is a very limited number of parameters which are specific to the control board or power board hardware. Table 3 provides the MCEWizard setup overview for hardware related parameters specific to EVAL-M1-05F310R power board. Similar tables will be available in each control board’s Application Note. A combination of this table and the corresponding table of the control board provides sufficient information to set up the MADK-based motor drive system rapidly.

Table 3 MCEWizard setup overview table

Parameter	Value
Control board selecting	EVAL-M1-101T for example
Power board selecting	EVAL-M1-05F310R
Motor 1 shunt configuration	Single shunt
Controller supply voltage	+3.3 V
Max DC bus voltage	80 V
DC bus sensing high resistor	1020 kΩ
DC bus sensing low side resistor	Refer to the control board user manual
NTC temperature shutdown value	Refer to the control board user manual
Gate sense low-side devices	High is true
Gate sense high-side devices	High is true
Motor 1 current input	Calculated in the corresponding section in control board user manual

After all the MCEWizard questions are answered, the “Verify & Save Page” will be shown as in Figure 5.

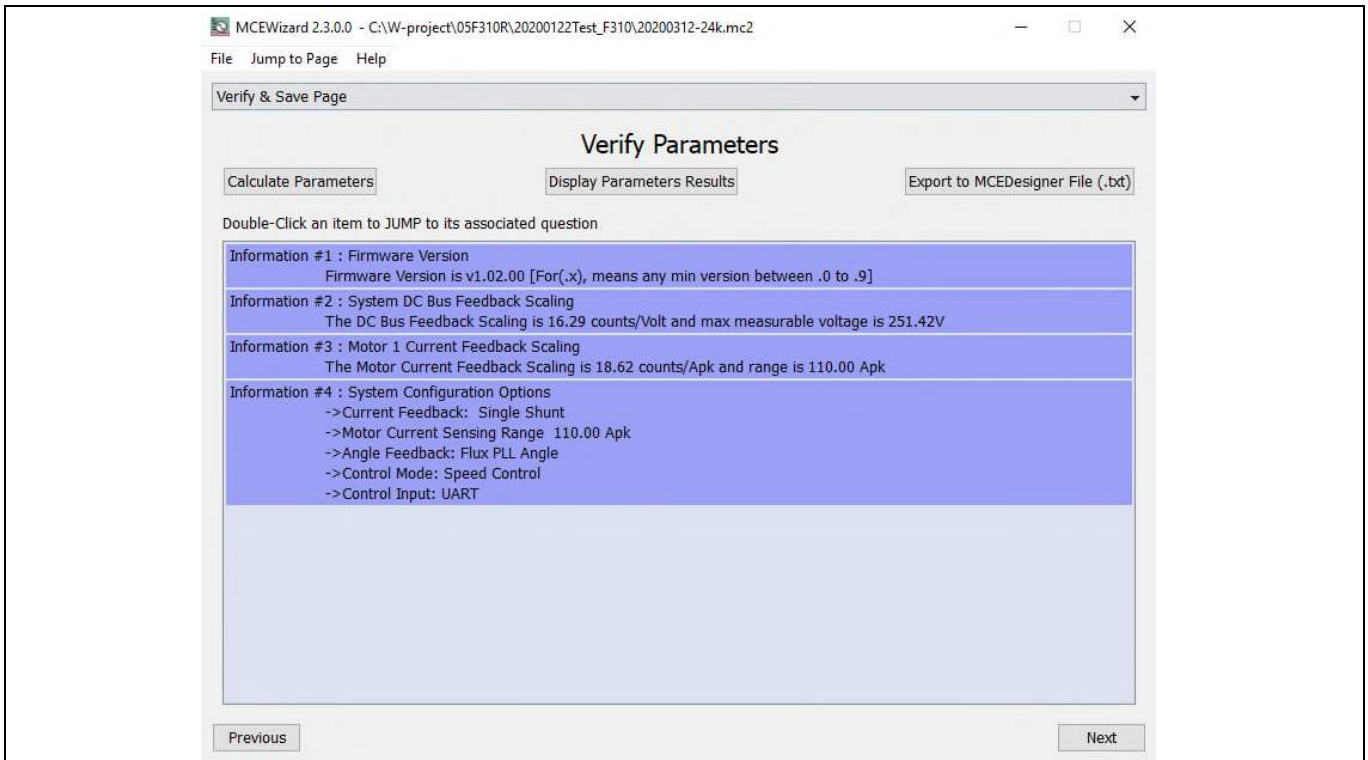

Figure 5 Verify and save page of the MCEWizard

Click “Calculate Parameters” button and “Export to Designer File (.txt)” button to save the parameter file which will be used by the MCEDesigner in the next steps.

2.1.4 MCEDesigner setup overview

After installing MCEDesigner, there is a shortcut for the MCEDesigner on Windows desktop. Double-click the shortcut to open MCEDesigner and then open “IMC101T_xx.irc” file as shown in Figure 6.

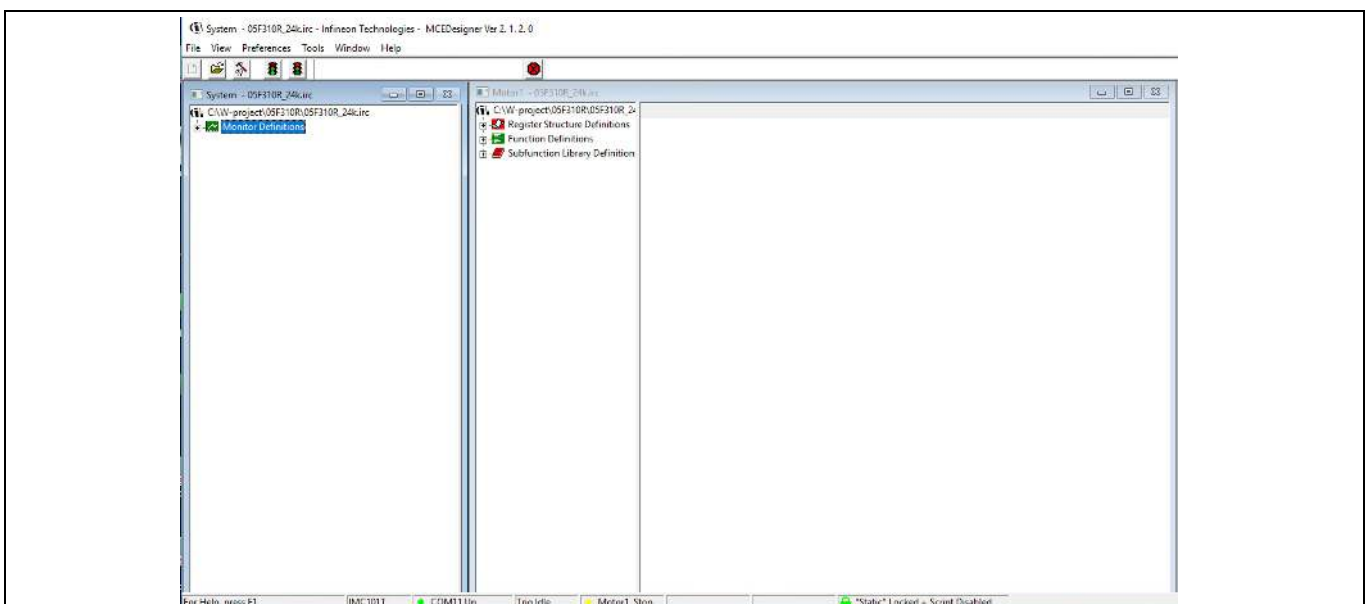

Figure 6 MCEDesigner’s main display for EVAL-M1-101T

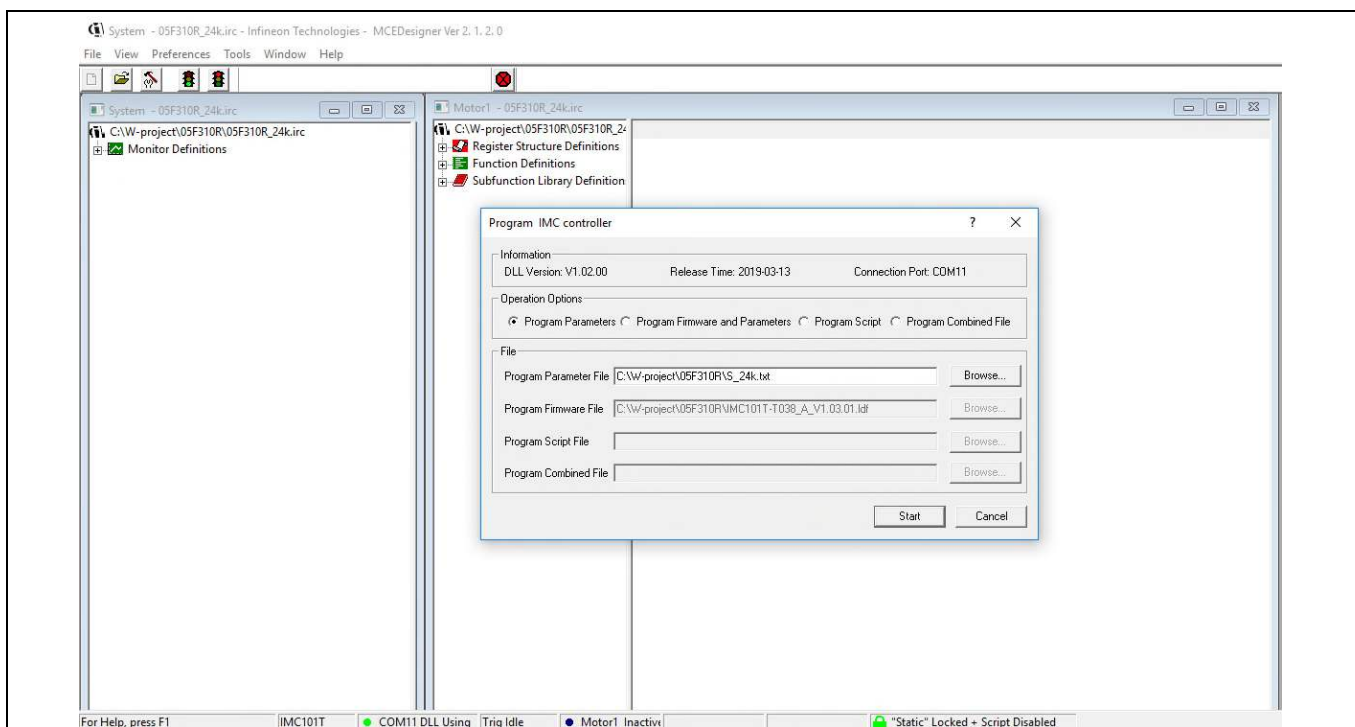

Figure 7 “Program IMC controller” pop-up window

After the drive system parameter file has been programmed into the IMC101 controller, and the motor drive system is powered, the MCEDesigner can be used to start/stop the motor, display motor current traces, change the motor speed, modify drive parameters and many other functions. Please refer to the MCEDesigner documentation for more details.

Note: The on-board debugger section of the EVAL-M1-101T has galvanic isolation from the controller section and the attached power board. In order to program the parameters or firmware to the IMC101T-T038 controller, the 3.3 V DC voltage needs to be supplied to the controller section of the EVAL-M1-101T. This voltage can either be supplied by the power board (MADK power boards are designed to supply the 3.3 V to the control board via M1 or M3 connector) or by feeding the 3.3 V voltage to the control board via some of the available 3.3 V access/test points if the power board is not attached to the EVAL-M1-101T control board.

To program new firmware and the drive system parameters into IMC101T-T038, please click the “Tools” menu and select “Programmer” in the pull-down list. The pop-up window “Program IMC controller” will show up as in Figure 8. Click on the “Program Firmware and Parameter” radio button, and select the “Drive System Parameter” file created using MCEWizard by clicking on the “Browse” button on the row of “Program Parameter File”, and then select the firmware file by clicking on the “Browse” button in the row of “Program Firmware File”. Finally, click on the “Start” button to program the parameter file into the IMC101T-T038 IC.

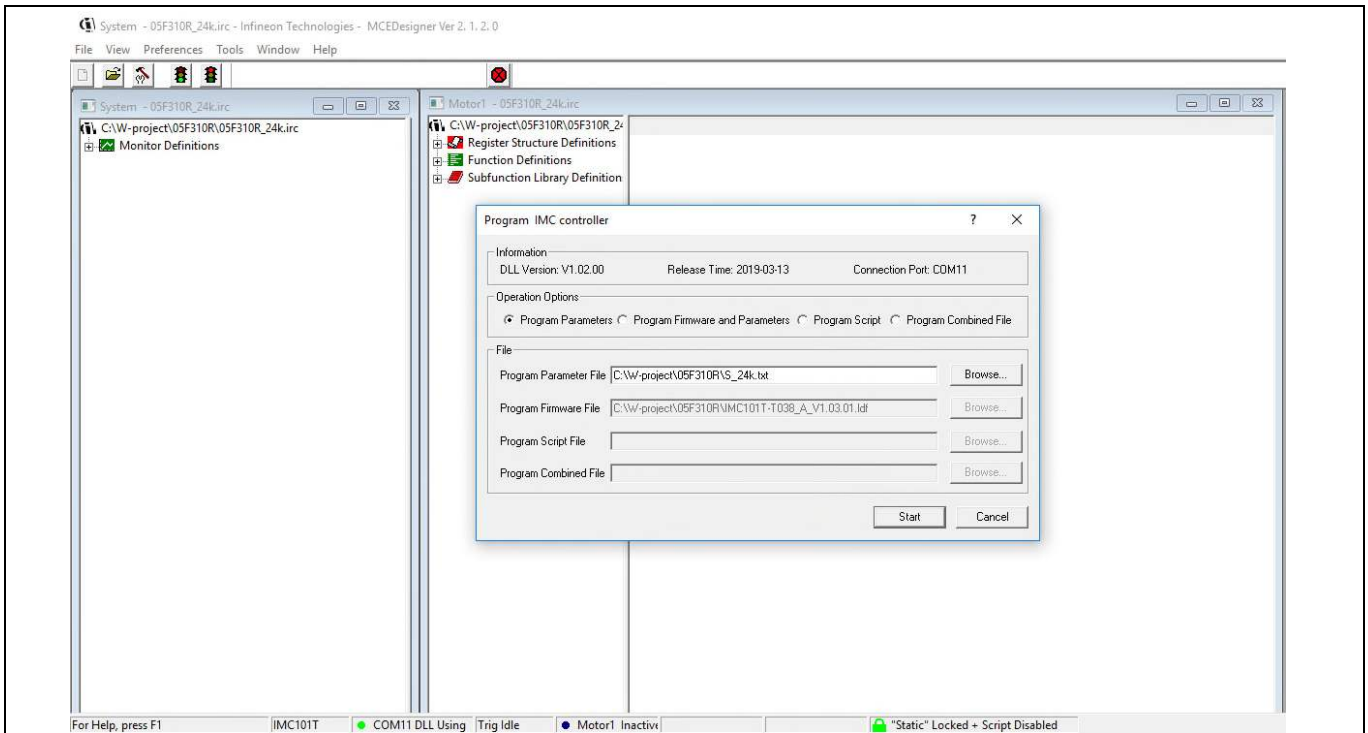

Figure 8 Program firmware and parameter in “Program IMC controller” pop-up window

2.2 The current waveform form MCEdesigner

MCEdesigner has a parameter trace function for debugging and checking the PCB layout/parameter settings in the “.irc” window.

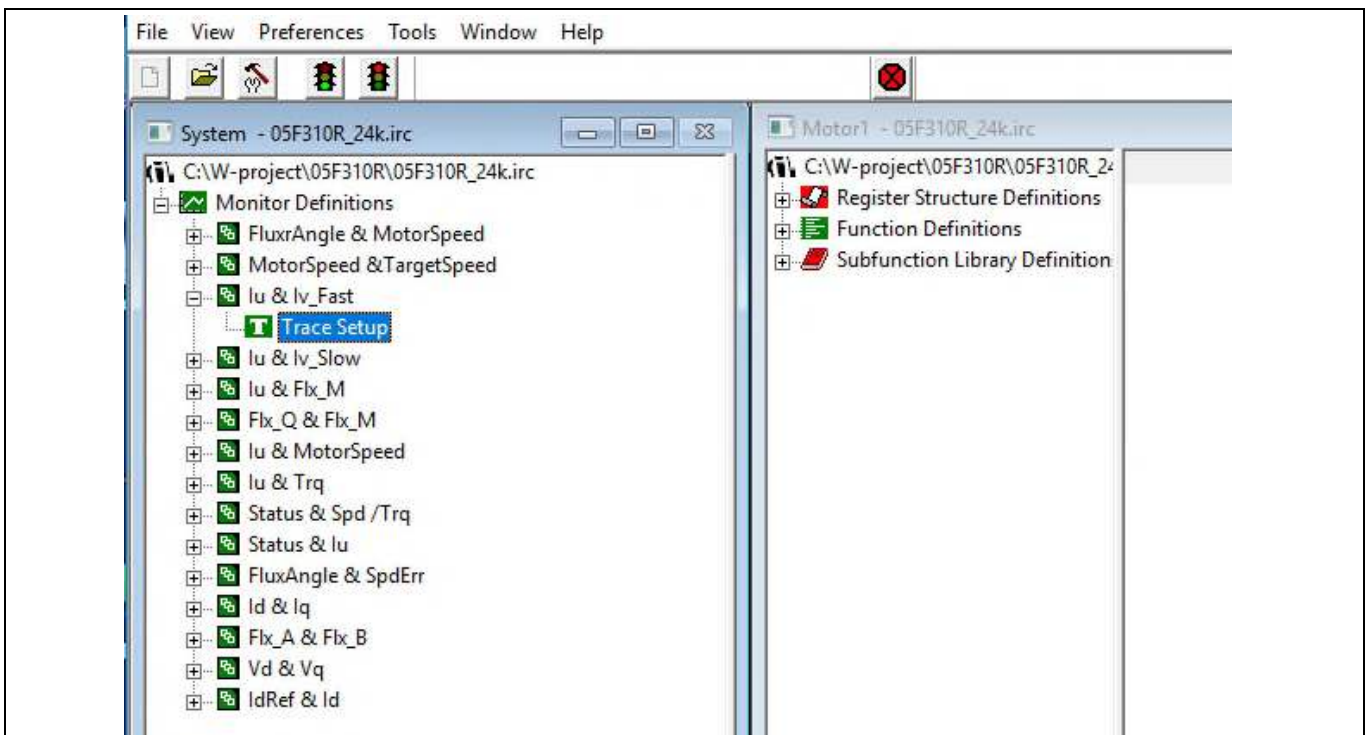

Figure 9 Trace function in MCEdesigner window

System and functional description

The trace function shows what the MCE 'saw'. The figures below are the motor current waveform at stop and running status.

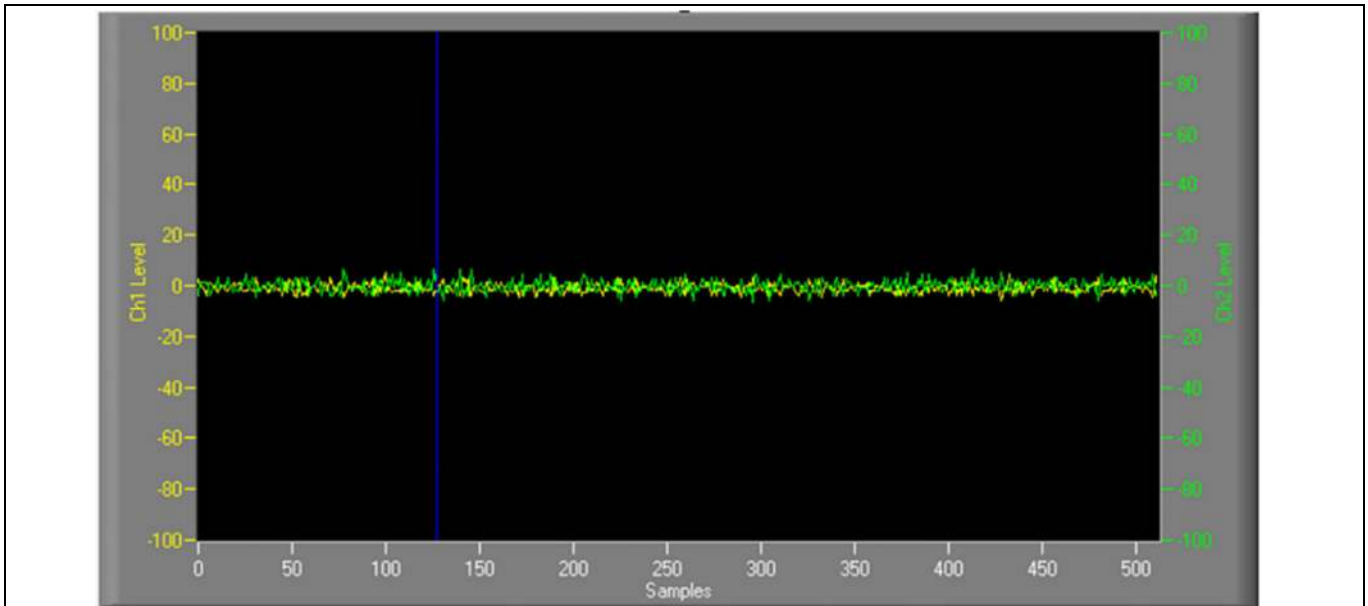

Figure 10 Iu and Iv static noise waveform from MCEDesigner

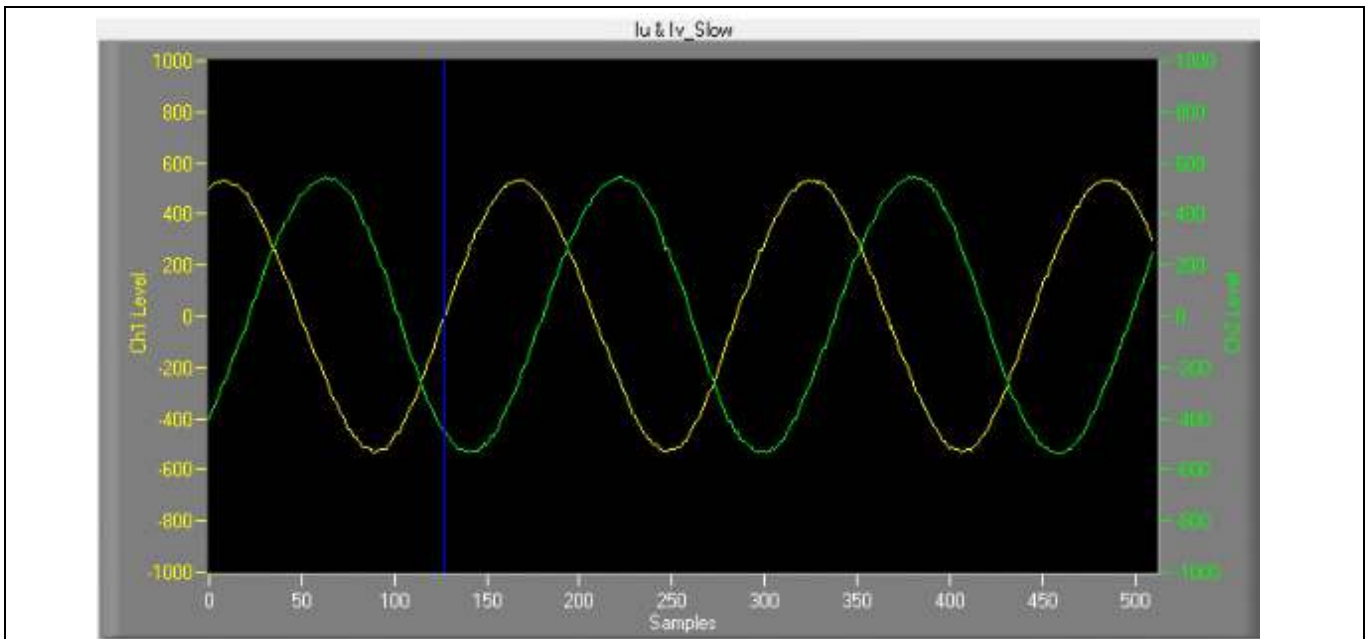

Figure 11 Iu and Iv waveform from MCEDesigner @ Iu and Iv @ Io=5.7 A, 48 VDC , 24 kHz

This is typical current waveform of a sinusoidal brushless motor driven by the EVAL-M1-05F310R and EVAL-M1-101T with iMOTION™ software.

2.3 Description of the functional blocks

The motor inverter of EVAL-M1-05F310R evaluation design is implemented by the IRSM005-301MH module, and the auxiliary power supply is based on the CoolSET™: ICE5GR4780AG.

System and functional description

2.3.1 Overview of IRSM005-301MH

Figure 12 provides the overview of the IRSM005-301MH internal electrical schematics. For further information regarding these CIPOS™ Nano such as static and dynamic electrical behavior, as well as thermal and mechanical characteristics, please refer to the datasheet of the IRSM005-301MH.

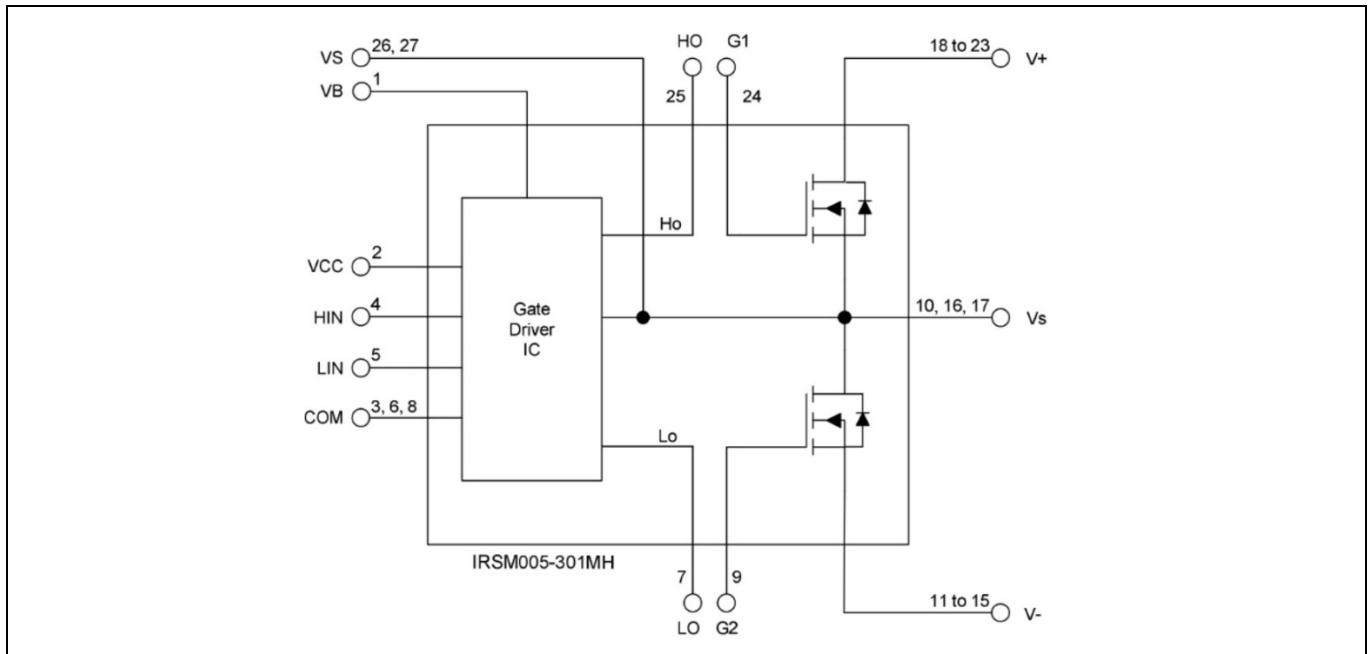

Figure 12 IRSM005-301MH internal electrical schematic

The main features of the CIPOS™ Nano IPM IRSM005-301MH include:

- MOSFET drain-to-source voltage 100 V
- Maximum DC current at 25°C case temperature $I_D = 30$ A
- Package with low thermal resistance and minimal parasitic inductance
- Independent gate driver in phase with logic input
- Gate drive supply is 15 V
- 3.3 V logic input compatible
- Undervoltage lockout protection inside the driver
- Exposed driver outputs and HEXFET gate terminals for dv/dt setting via a resistor

Table 4 Absolute maximum ratings of IRSM005-301MH

Symbol	Description	Min	Max	Unit
V_{DS}	MOSFET drain-to-source voltage	--	100	V
I_D	Maximum DC current per MOSFET @ $T_c = 25^\circ\text{C}$.	--	30	A
P_d	Maximum power dissipation per MOSFET @ $T_c = 100^\circ\text{C}$.	--	13.5	W
T_J (MOSFET & IC)	Operating junction temperature.	--	150	$^\circ\text{C}$
T_s	Storage temperature range.	-40	150	$^\circ\text{C}$
V_B	High side floating supply voltage.	-0.3	$V_s + 20$	V

System and functional description

V_S	High side floating supply offset voltage.	V_B-20	$V_B+0.3$	V
V_{CC}	Low side fixed supply voltage.	-0.3	20	V
V_{IN}	Low input voltage of LIN, HIN.	-0.3	$V_{CC}+0.3$ V	V

2.3.2 Overview of ICE5GR4780AG

The ICE5GR4780AG is single power chip that is Infineon's CoolSET™, offers high performance, high efficiency and easy to use with DC 30~600 V super wide voltage range industrial auxiliary power supply for super buck with DC 36 ~ 540 V standard industrial aided design.

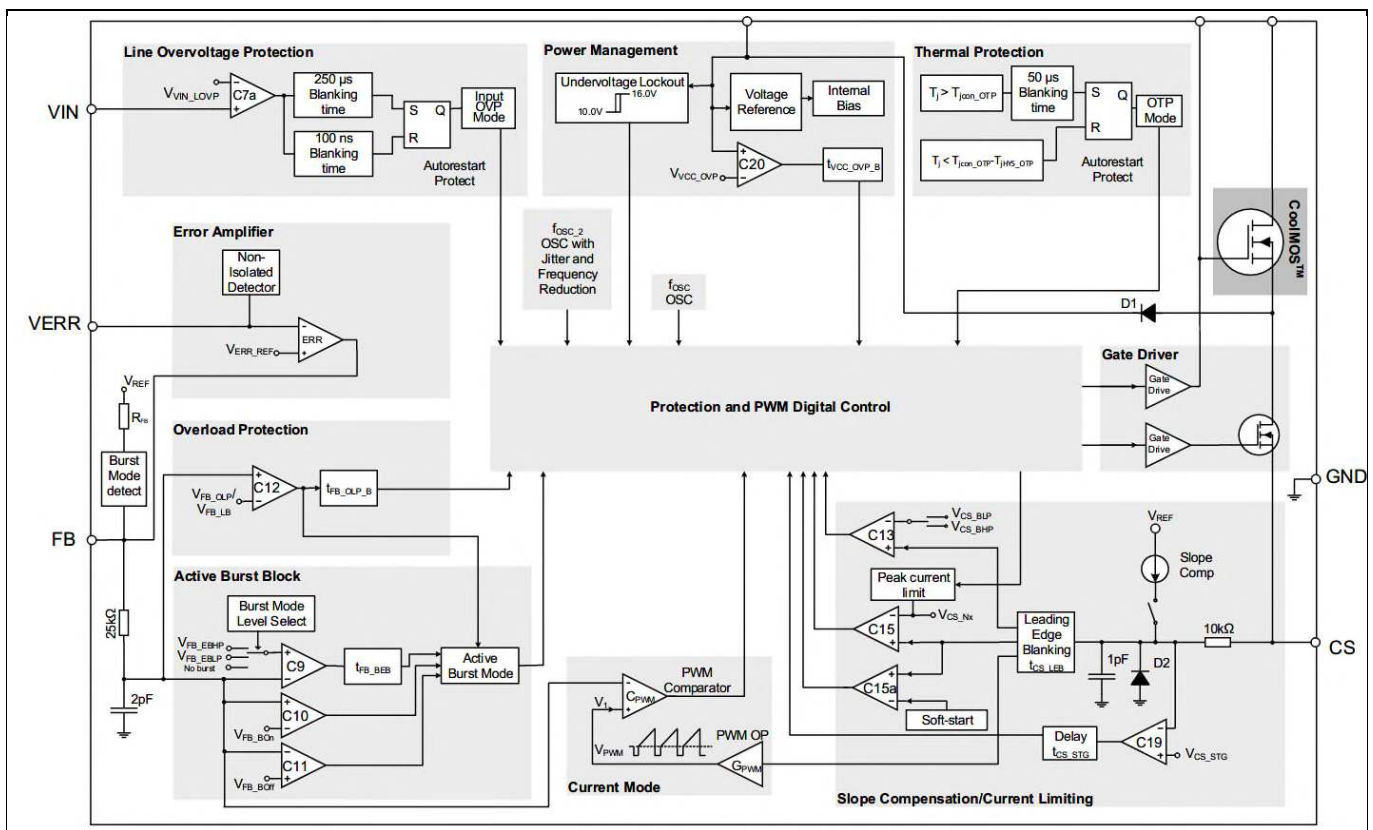

Figure 13 ICE5GR4780AG internal electrical schematic

Features

- Integrated 800 V avalanche rugged CoolMOST™
- Enhanced Active Burst Mode with selectable entry and exit standby power to reach the lowest standby power <100 mW
- Digital frequency reduction for better overall system efficiency
- Fast startup achieved with cascode configuration
- DCM and CCM operation with slope compensation
- Frequency jitter and soft gate driving for low EMI
- Built-in digital soft start
- Integrated error amplifier to support direct feedback in non-isolated flyback
- Comprehensive protection with input line over voltage protection, V_{CC} over voltage, V_{CC} under voltage, overload/open loop, over temperature

System and functional description

- All protections are in auto restart mode
- Limited charging current for V_{CC} short to GND



EVAL-M1-05F310R user guide

Modular application design kit (MADK) of IRSM005-301MH

System design

3 System design

The EVAL-M1-05F310R board is an optimized design for DC30~72V major home and industry appliances. To meet individual customer's requirements and to make the EVAL-M1-05F310R evaluation design a basis for development or modification, all board design data such as schematics, Gerber and Altium design data can be found on the Infineon homepage and log in your account to download them.

3.1 Inverter section using CIPOS™ Nano

Three CIPOS™ Nanos are used to build up the inverter section as shown in Figure 14. Three half-bridge modules are used as the 3-phase inverter bridge section. Every half-bridge module includes two power MOSFETs and one half-bridge gate driver. The shunt resistor section is also given. The three capacitors C4, C5 and C6 are used as bootstrap capacitors to provide the necessary floating supply voltages VBU, VBV and VBW respectively.

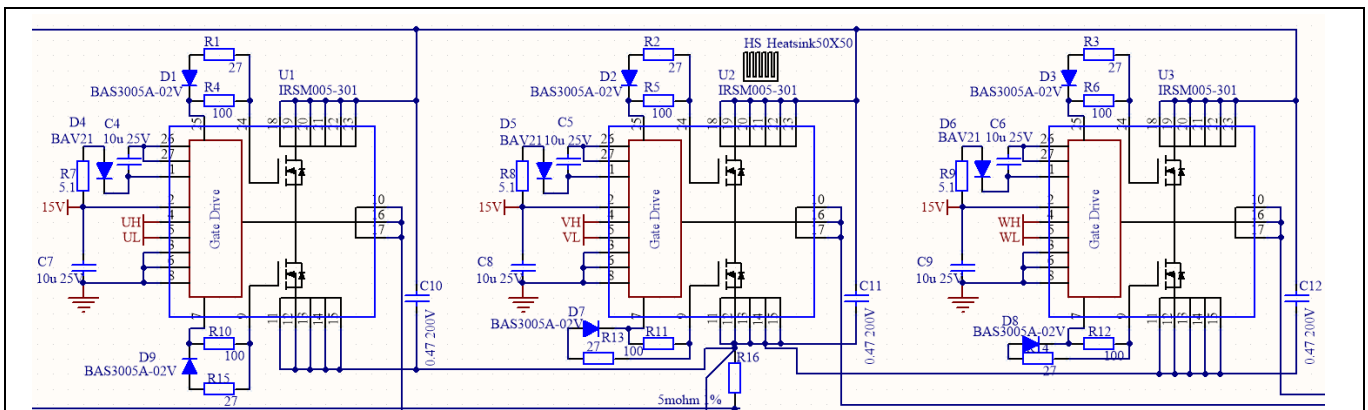

Figure 14 Schematic of the inverter section

3.2 DC to DC power converter

Figure 15 depicts the schematic of the super buck for auxiliary power supply available on the EVAL-M1-05F310R board. The circuit includes ICE5GR4780AG that is used to generate 15 V (VCC) directly from the DC bus. VCC is connect to the gate drivers inside the CIPOS™ Nano. The linear regulator TPS56043XF generates 3.3 V from VCC. The 3.3 V power supply is used in the overcurrent comparator circuit. Red LED1 is used to signal whether the board is powered or not. Both, VCC and 3.3 V are also present on the 20-pin interface connector J3 to power circuitry on the controller board.

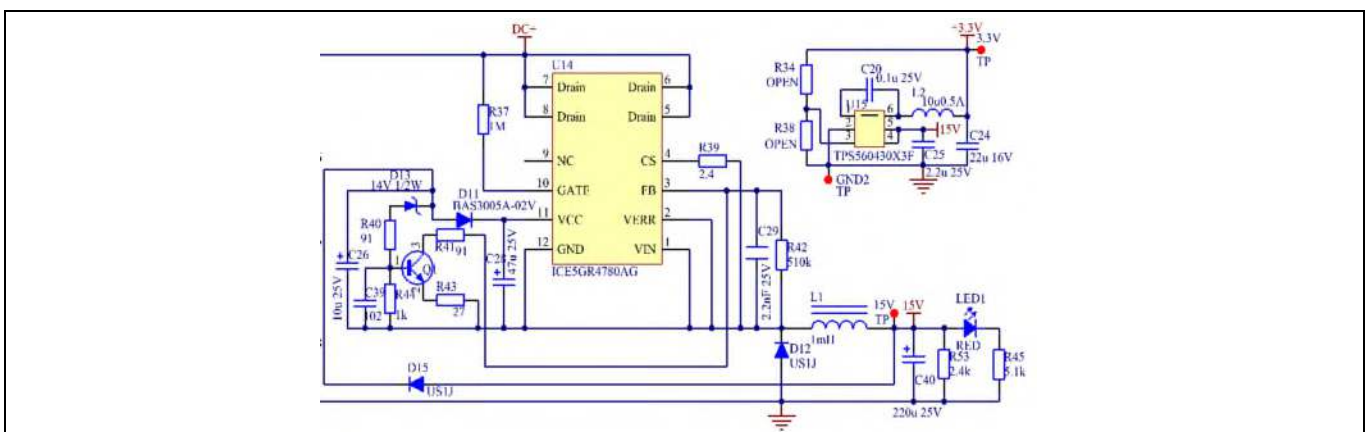

Figure 15 Power supply section

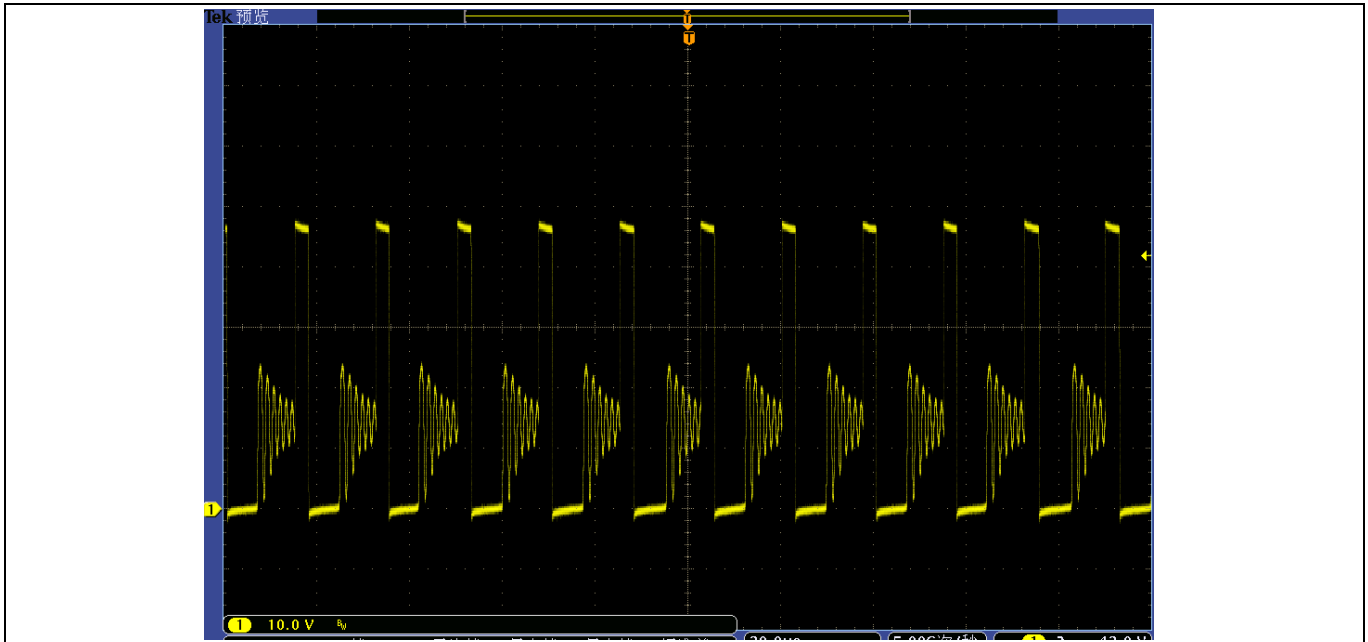

Figure 16 U14 (Pin12) output type waveform at 48 V DC input

3.3 DC bus voltage measurement

Pin 14 of connector J3 provides access to the DC bus voltage. Three possible feedback cases are associated with this pin.

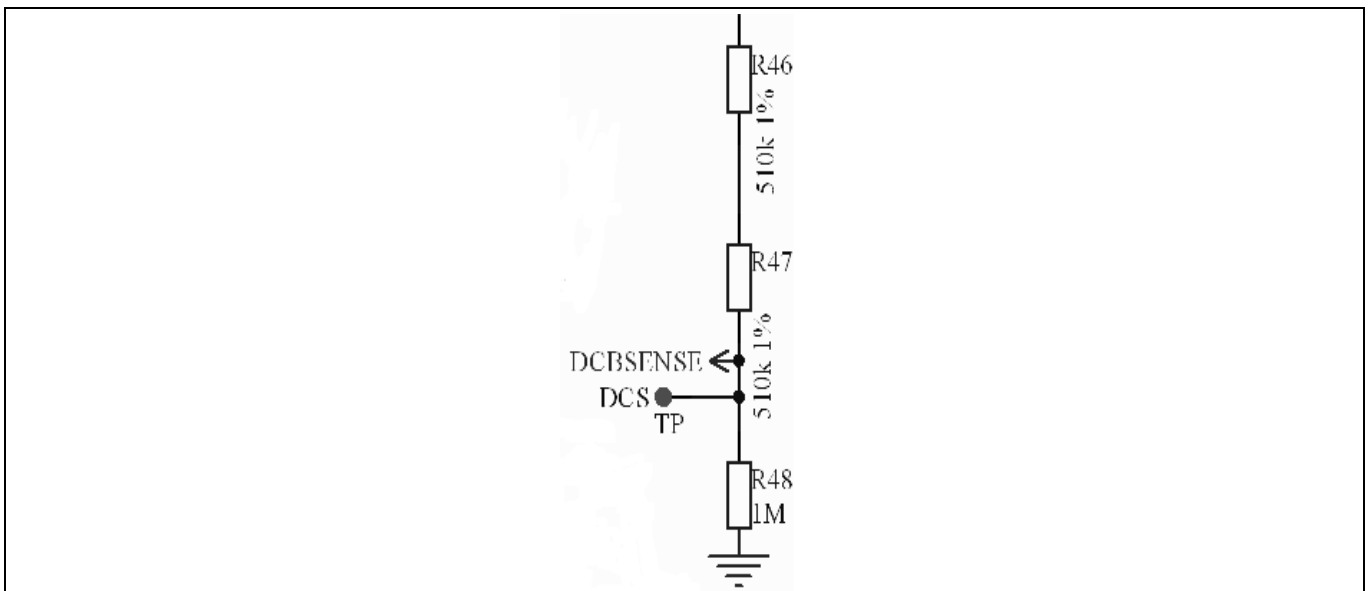

Figure 17 DC bus sensing

R48 is the safety resistance on the connection port when the connector is open. The DC bus sensing low side resistance is $R_{48} // R_1$ (R_1 is the pull-down resistor on EVAL-M1-101T). It is:

$$\sum R_{\text{low side}} = \frac{1 \text{ M}\Omega \times 13.3 \text{ k}\Omega}{1 \text{ M}\Omega + 13.3 \text{ k}\Omega} = 13.13 \text{ k}\Omega$$

System design

3.4 Current sensing and amplifying

The current feedback of EVAL-M1-05F310R is single-shunt sensing by R16. It is 5 mΩ. The current output IU+ and IU- goes to J3.

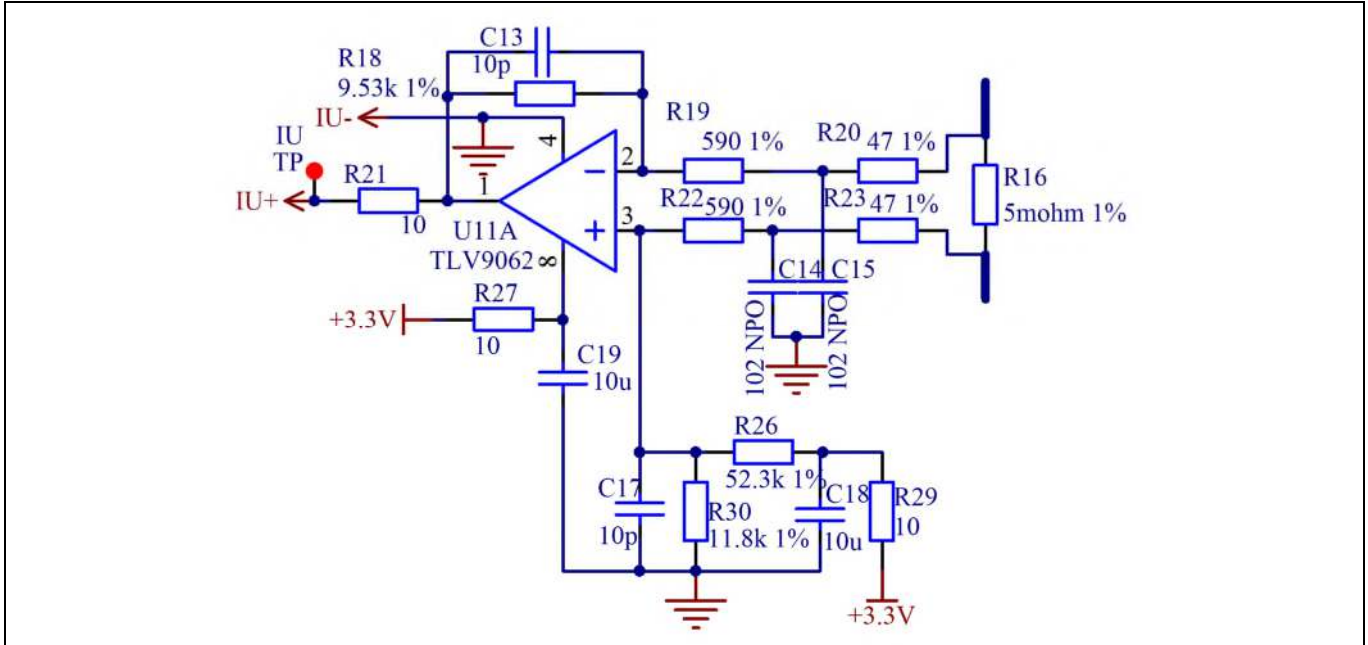

Figure 18 Current sense and signal amplification

An LPF consists of R20/R23/C14/C15 to remove EMC noise from R16. The current amplifier consists of R18/R19/R20/R22/R23/C13 U1A for lower noise and proportional amplifier.

The gain of the amplifier is:

$$G = \frac{R18 + R19 + R20}{R19 + R20} = 15.96$$

The current scaling is:

$$V_{shunt} = R16 \times G = 79.8 \text{ mV/A}$$

Static status:

$$V_o = \frac{R30 \times 3.3 \text{ V}}{R26 + R29 + R30} = 0.607 \text{ V}$$

The response time:

$$T_0 = \frac{1}{\frac{GBWP_{U11a}}{A - 1}} = 1.5 \mu\text{s}$$

R21 matches the resistance with U11A output. The GBWP is gain bandwidth of U11.

3.5 Current feedback to the control board

The circuit below shows the feedback current signal to the control board. The offset circuit consists of R6 and 3.3V.

System design

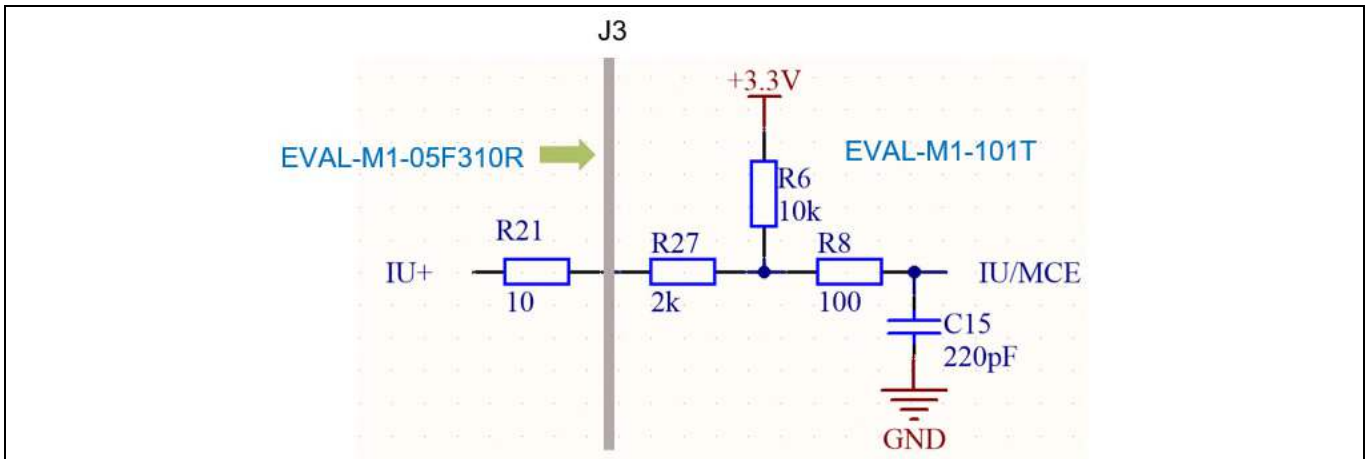

Figure 19 Current signal transmission of EVAL-M1-05F310R+EVAL-M1-101T

The attenuation of the current signal from IU+ to IU:

$$\alpha = \frac{R6}{R6 + R21 + R27} = 0.833$$

Total gain to IU input:

$$\sum G = \alpha \times G = 13.29$$

Total current scaling to IU input:

$$V_{shunt2} = R16 \times \sum G = 66.4 \text{ mV/A}$$

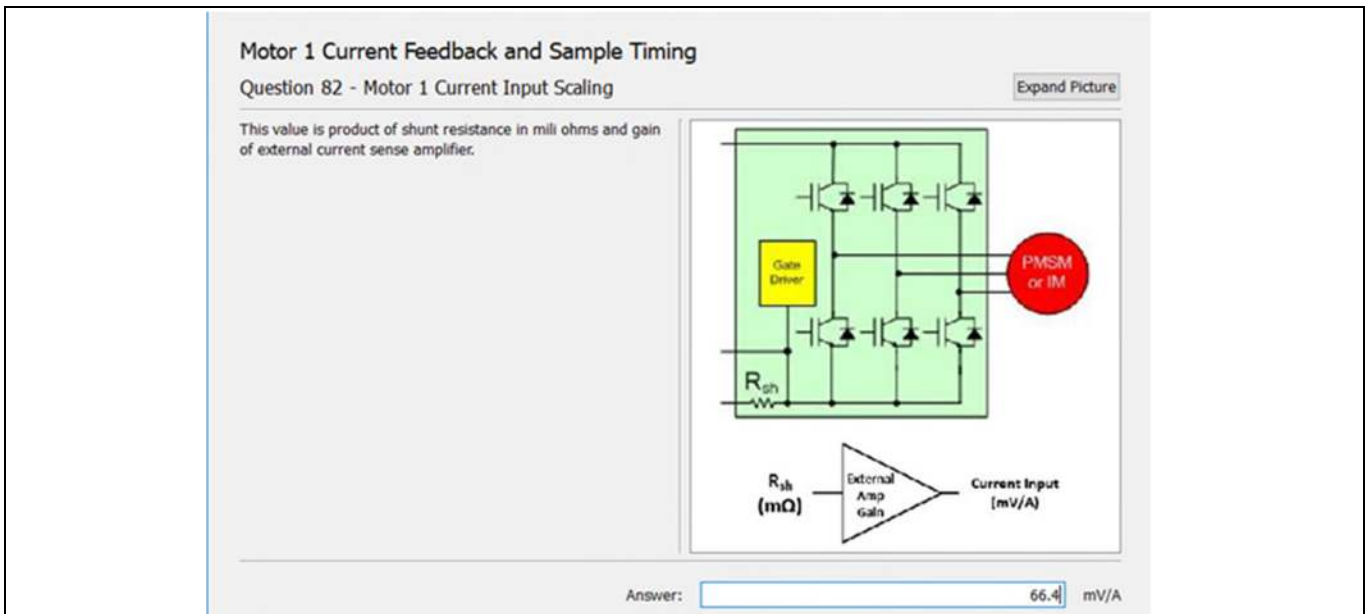

Figure 20 Current input scaling setup in MCEWizard

The current offset to IU input:

$$V_{offset} = (3.3 \text{ V} - 0.6 \text{ V}) \times \frac{R21 + R27}{R6 + R21 + R27} + 0.6 \text{ V} = 1.06 \text{ V}$$

EVAL-M1-05F310R user guide

Modular application design kit (MADK) of IRSM005-301MH

System design

Since the control board of the ADC range is 3.3 V, we have to select the internal gain of control board to “1”.

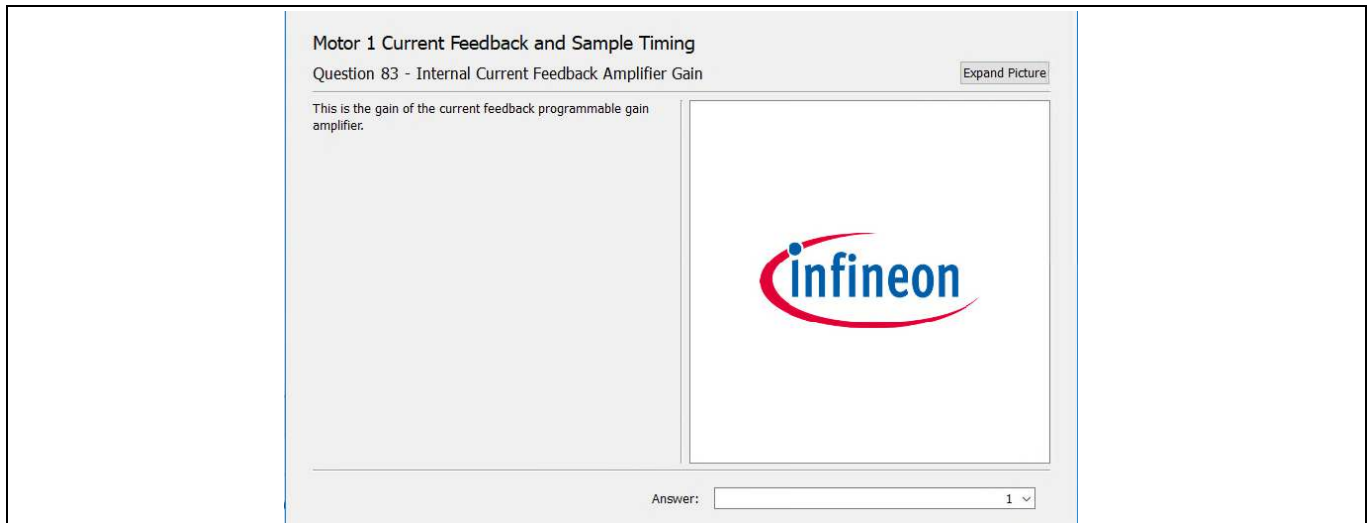

Figure 21 Setup current signal gain to “1”

3.6 OCP, GK and IOCP setup

Figure 22 is the overcurrent protection (OC) and gate kill (GK) circuit. The PWMUH, PWMUL, PWMVH, PWMVL, PWMWH, PWMWL are three-phase 3.3 V level PWM from J3 (from EVAL-M1-101T). UH, UL, VH, VL, WH, WL is 3.3 V level PWM to U1, U2, U3 (IPM). The following: R51, R52, R54, R55, R56, R57 are input resistors for damping noise from connections. R58, R59, R60, R61, R62, R63 are pull-down resistors for preventing noise from input open (J3).

3.6.1 OCP setup on EVAL-M1-05F310R

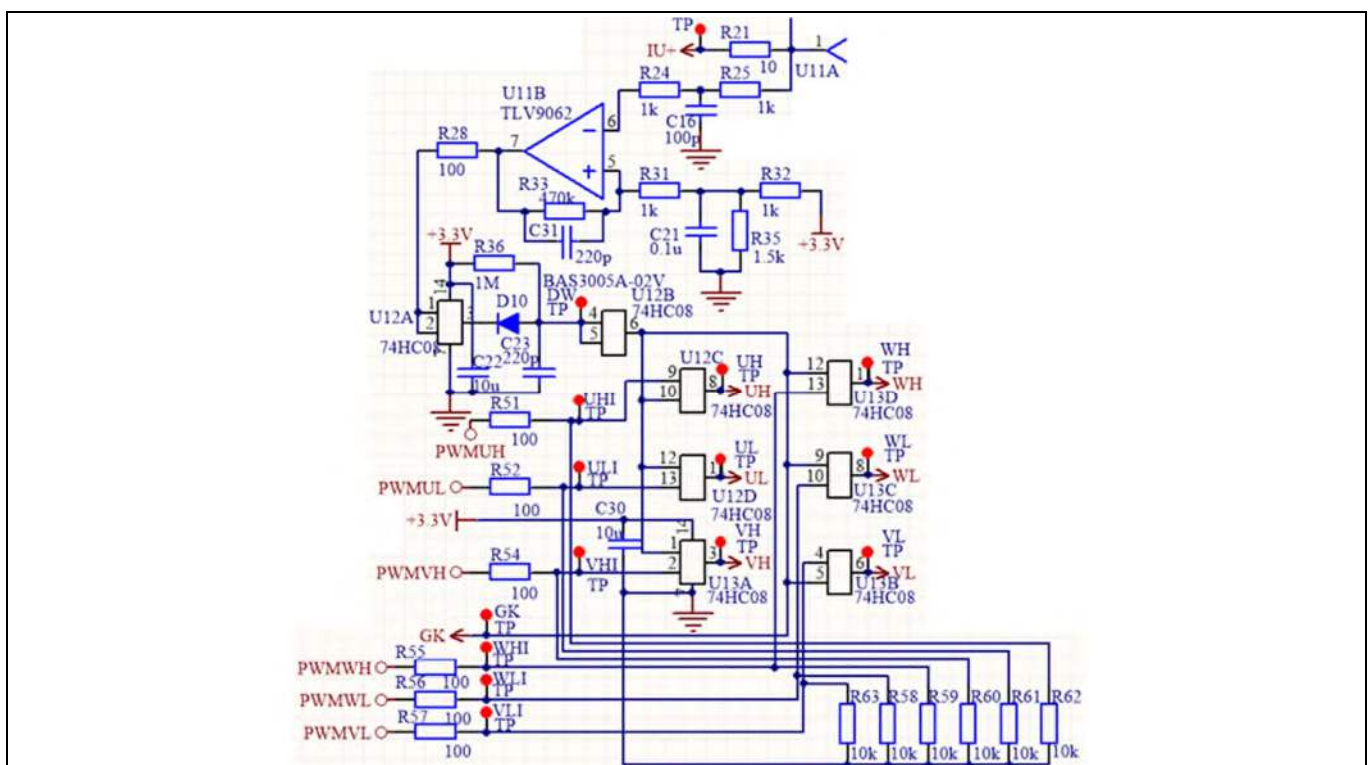

Figure 22 Overcurrent and GK/PWM shutdown

System design

The threshold voltage of the schmid trigger (U11B) is set to:

$$V_{\text{TriphTH}} = \frac{R35}{R32 + R35} \times 3.3 \text{ V} = 1.98 \text{ V}$$

The reflected overcurrent threshold:

$$I_{\text{TriphTH}} = \frac{V_{\text{TriphTH}} - V_o}{V_{\text{shunt1}}} = 17.2 \text{ A}$$

The response time:

$$T_D = R25 \times C16 = 100 \text{ ns}$$

When shunt current is over 17.2 A, U11B pin 7 outputs “0”.

3.6.2 PWM shutdown and GK output

U12A is a buffer circuit for the comparator. When overcurrent occurs, U11B pin 7 outputs “0”, C23 will be fast. A logic “0” signal appears on the output of U12B. This is a shutdown signal for all PWM inputs. This is also a gate-kill signal to J3 to inform the control board to stop PWM output. The total delay time of the shutdown is:

$$\sum T_D = T_O + T_D = 1.5 \mu\text{s} + 0.1 \mu\text{s} = 1.6 \mu\text{s}$$

When the over current is removed. U11B will go logic “1”. C23 will be charged by R36. The charge time constant is:

$$T_{\text{up}} = R36 \times C23 = 220 \mu\text{s}$$

For each overcurrent, U12B will output about 220 μs “0” for shutdown PWM and branch control system through J3.

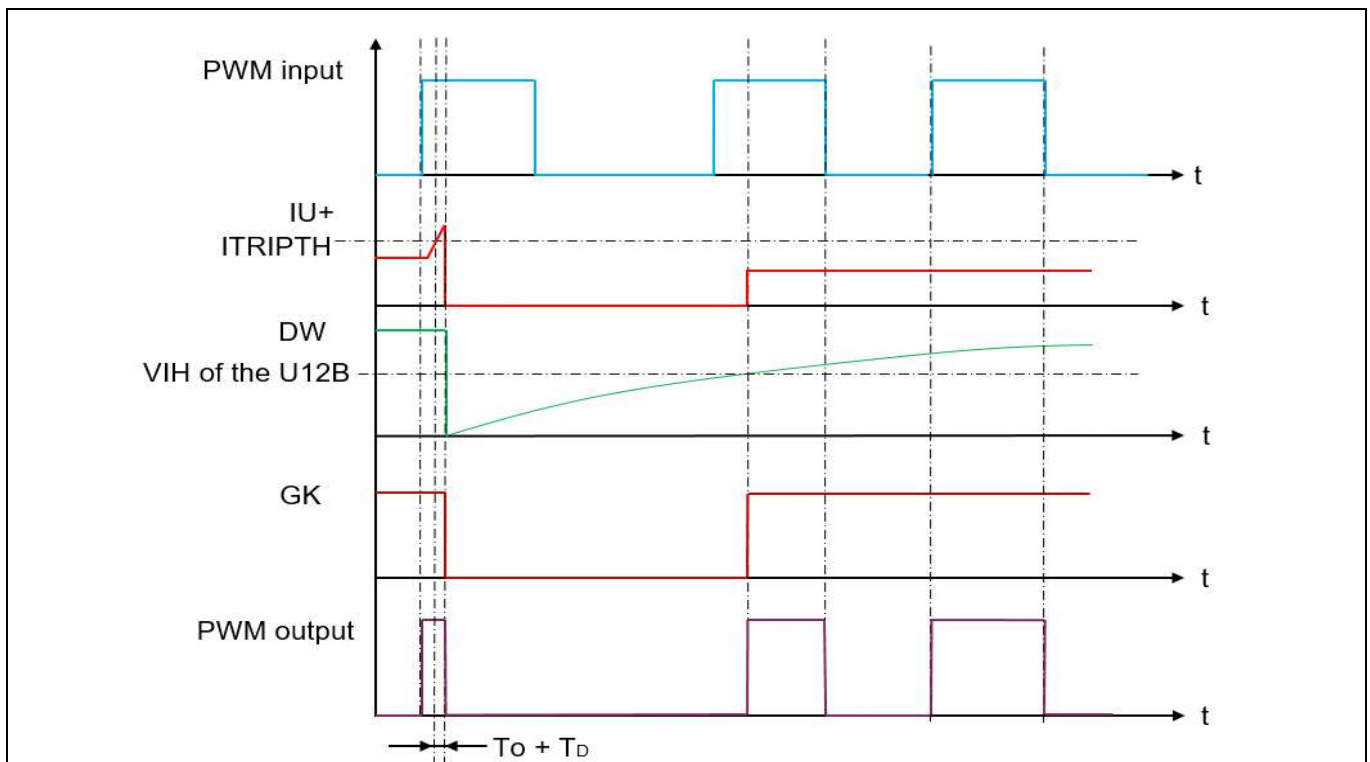

Figure 23 Logic of PWM input/output and DW/GK

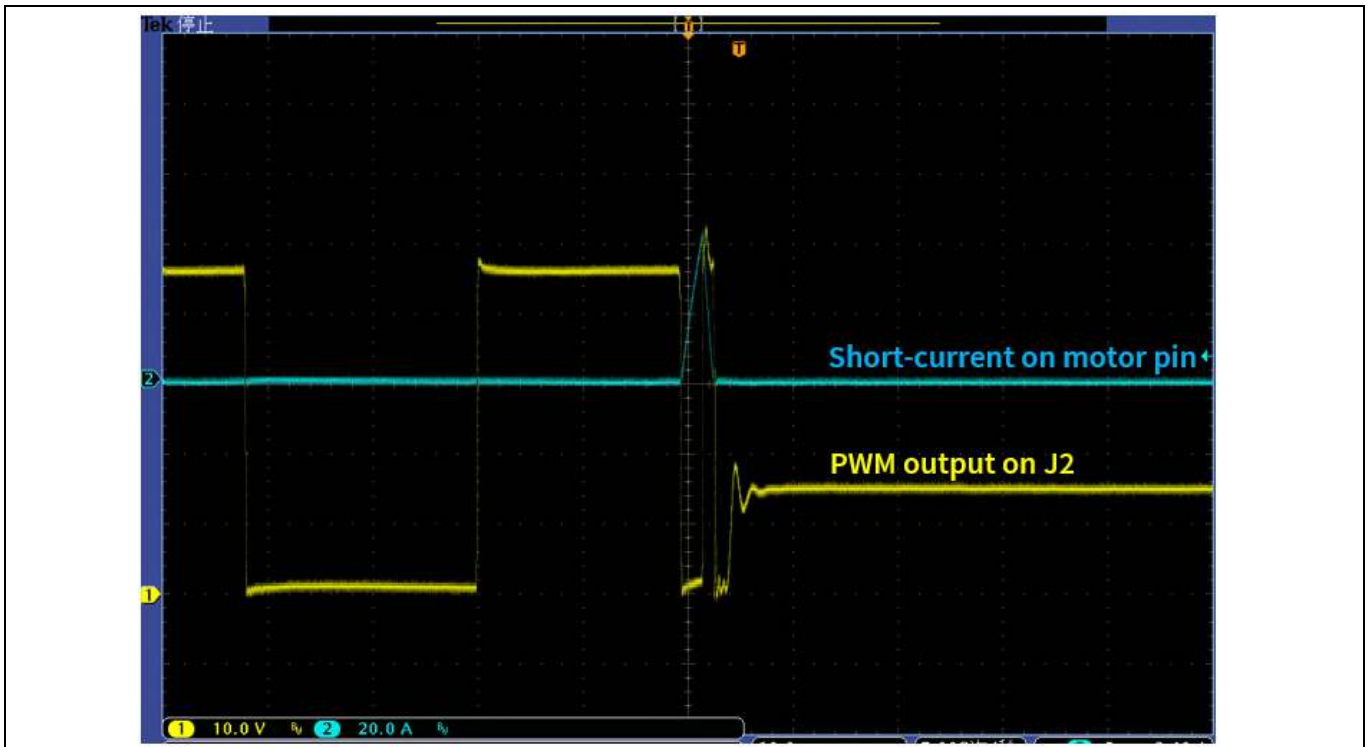

Figure 24 Waveform of overcurrent and PWM shutdown

3.6.3 OCP setup in MCEWizard

EVAL-M1-101T has an internal comparator. The default value of the threshold is 1.8 V (corresponding 17 A).

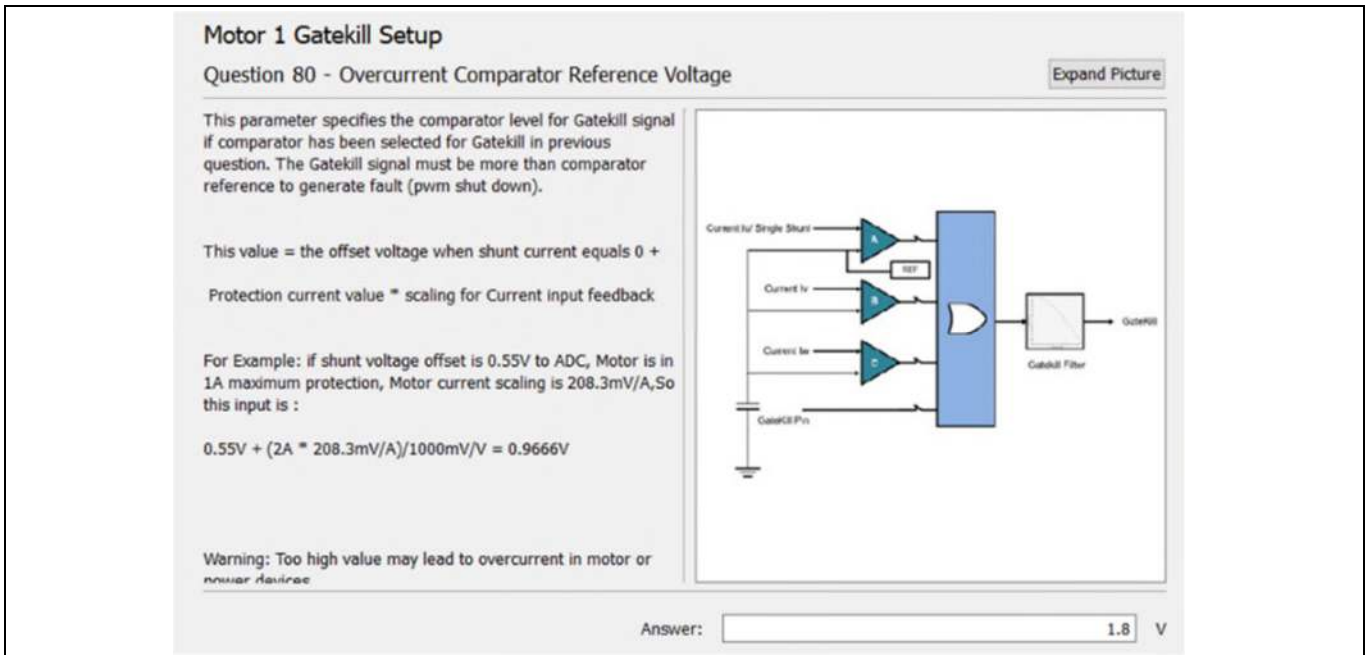

Figure 25 Overcurrent setup in MCEWizard

To calculate overcurrent protection threshold for MCEWizard based on EVAL-M1-05F310R board, use the formula below to calculate the voltage threshold value based on your selected overcurrent (IOCP).

EVAL-M1-05F310R user guide

Modular application design kit (MADK) of IRSM005-301MH

System design

$$V_{ref} = V_{offset} + V_{shunt2} \times I_{OCP}$$

$$= 1.06 \text{ V} + \frac{66.4 \text{ mV/A} \times I_{OCP}}{1000}$$

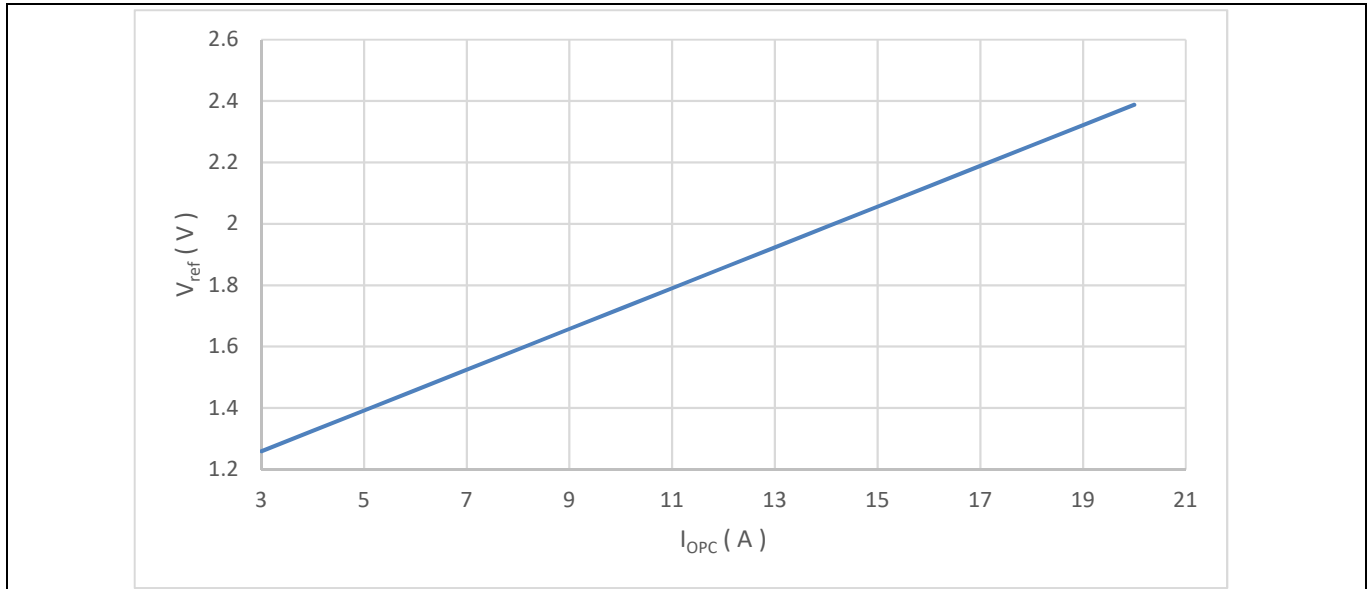

Figure 26 V_{ref} vs overcurrent (I_{opc})

3.7 NTC thermistor characteristics and over-heating protection calculation

EVAL-M1-05F310R has an NTC (R46) to measure T_c for over-temperature protection on top of U2. This temperature value is sent to EVAL-M1-101T. The part number is NTC is NXRT 15WF 104FA1B.

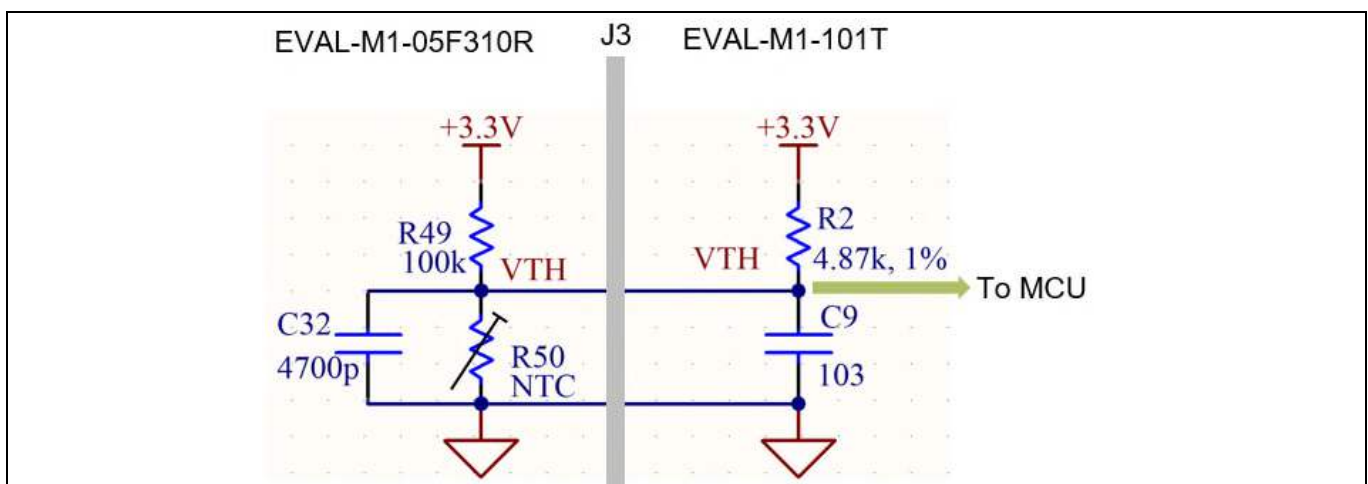

Figure 27 NTC(R50) on EVAL-M1-05F310R and connection to EVAL-M1-101T via J3

VTH output value vs temperature is shown in Figure 28. MCEWizard type setup is shown in Figure 29.

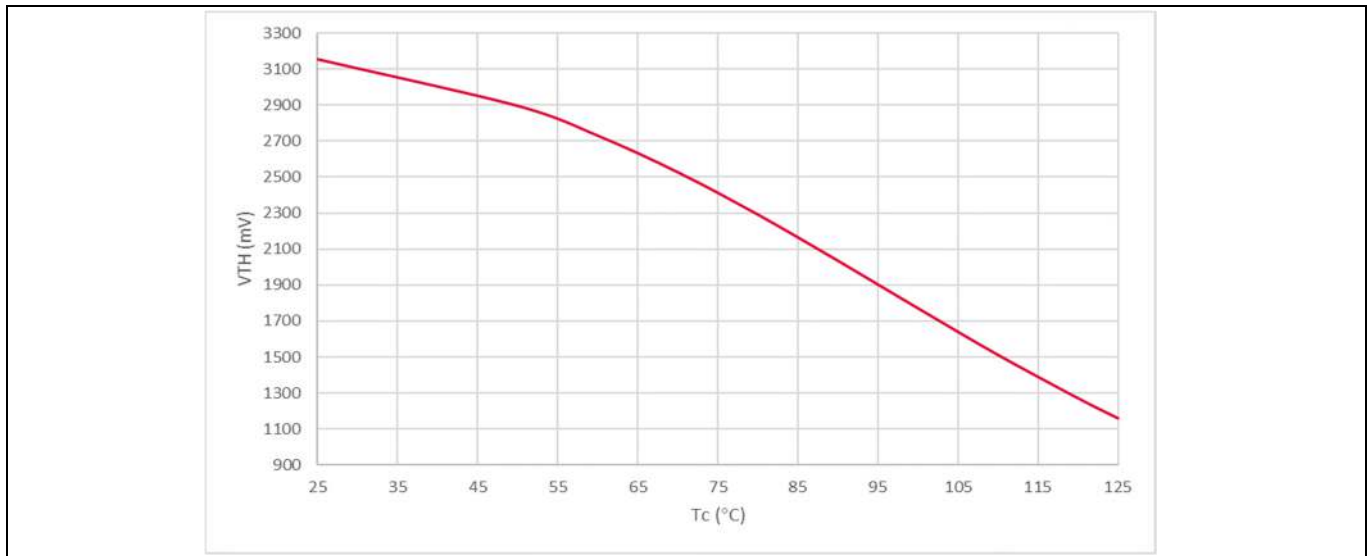

Figure 28 VTH output to EVAL-M1-101T

Motor 1 Fault Conditions

Question 67 - NTC Temperature Shutdown Value Expand Picture

Set voltage value for NTC Temperature Shutdown if Over Temperature Shutdown is enabled.

If Over Temperature Shutdown is enabled and voltage at AIN pin for NTC is below this value, motor will stop and enter fault state

Answer: V

Figure 29 NTC temperature shutdown on MCEWizard

3.8 Layout

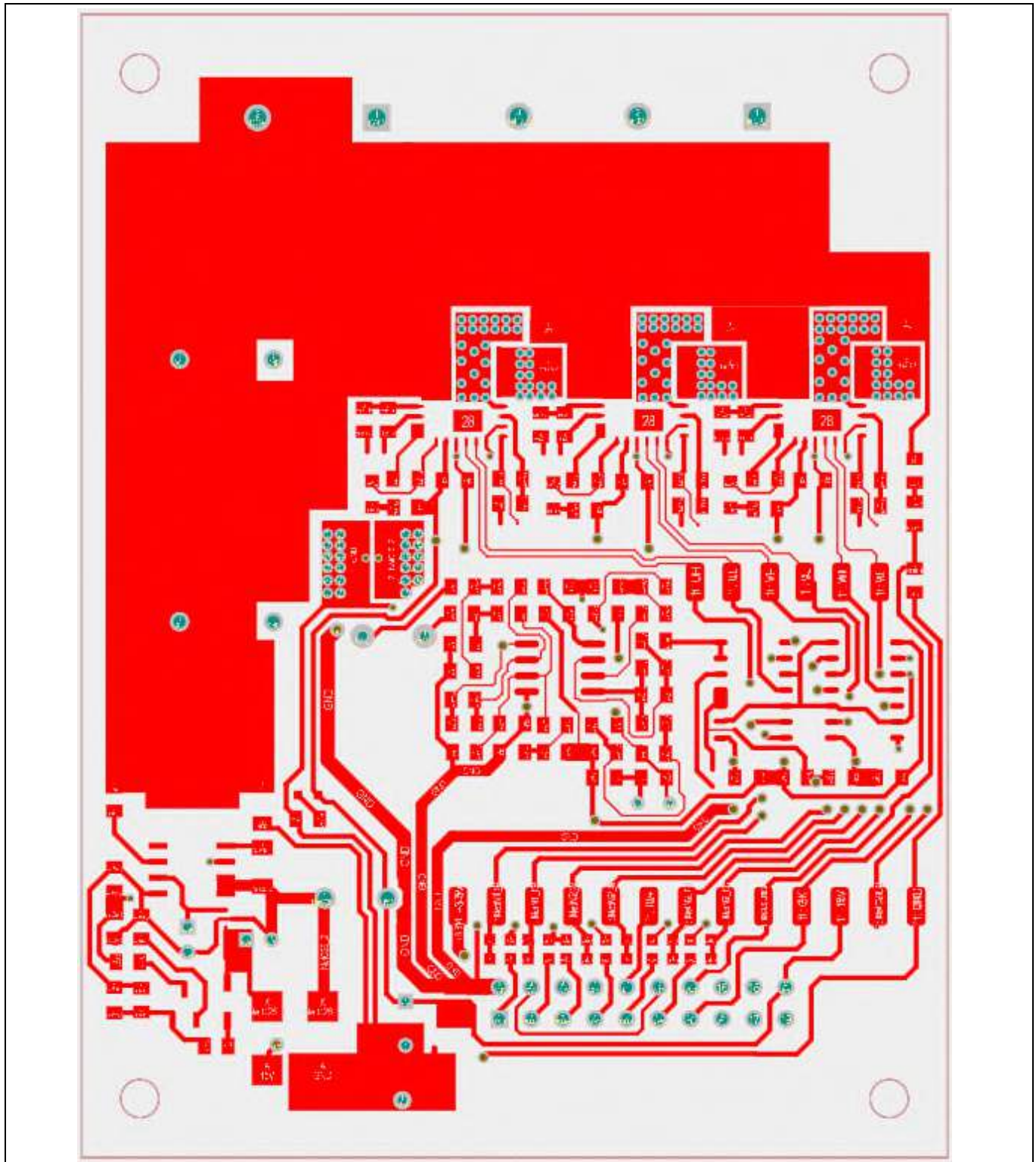

Figure 30 Top layer

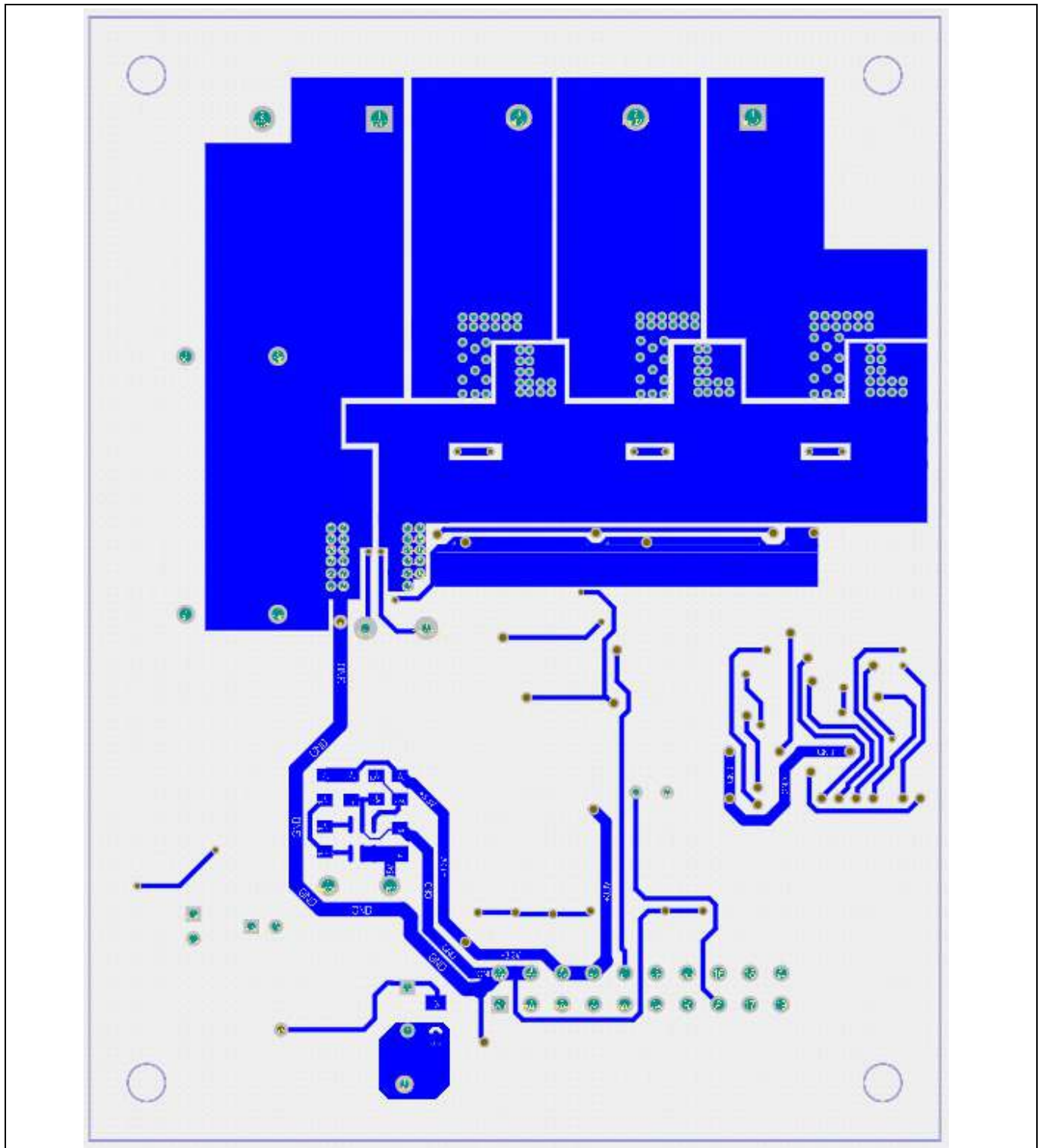

Figure 31 Bottom layer

System design

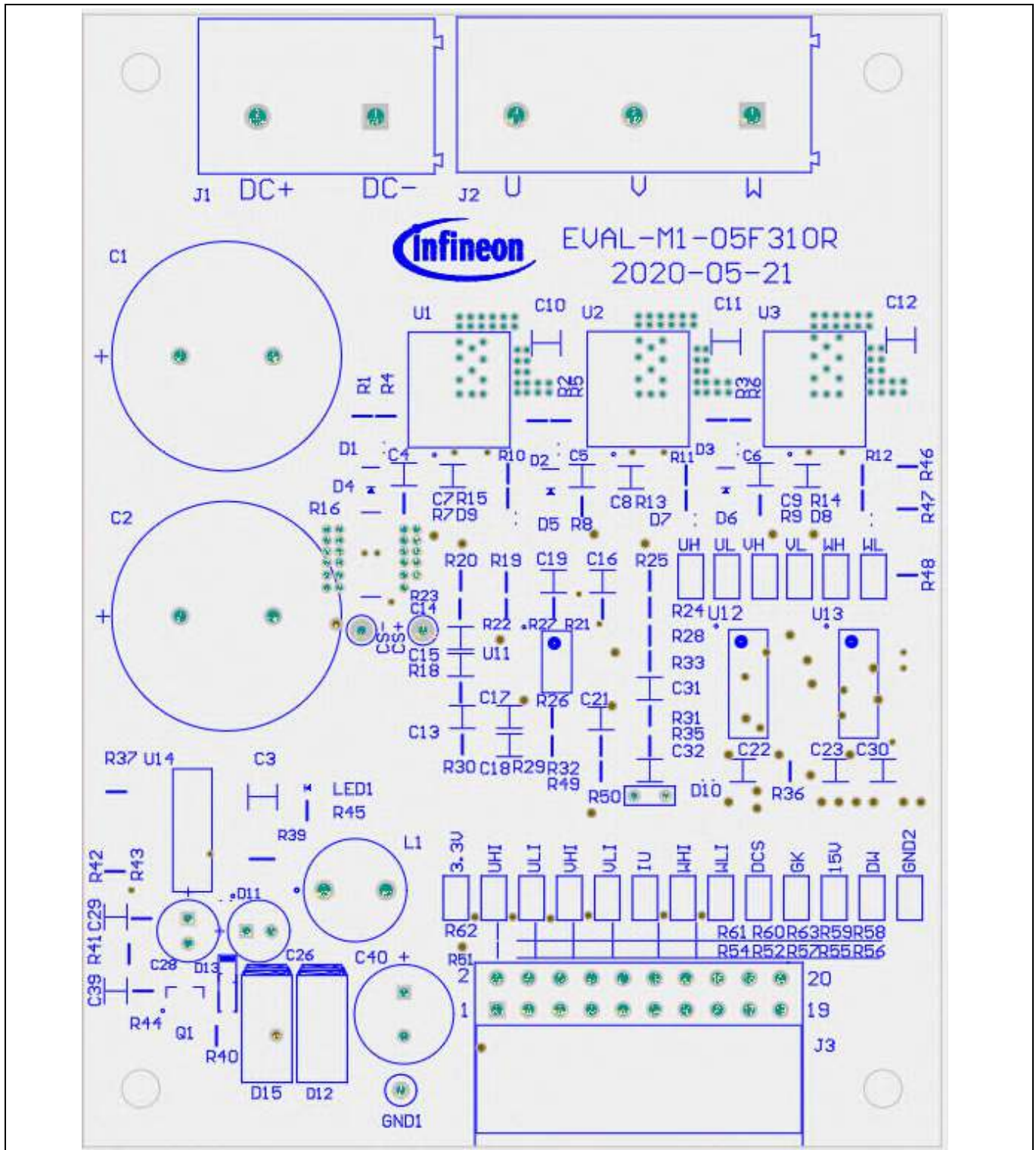

Figure 32 Top over layer

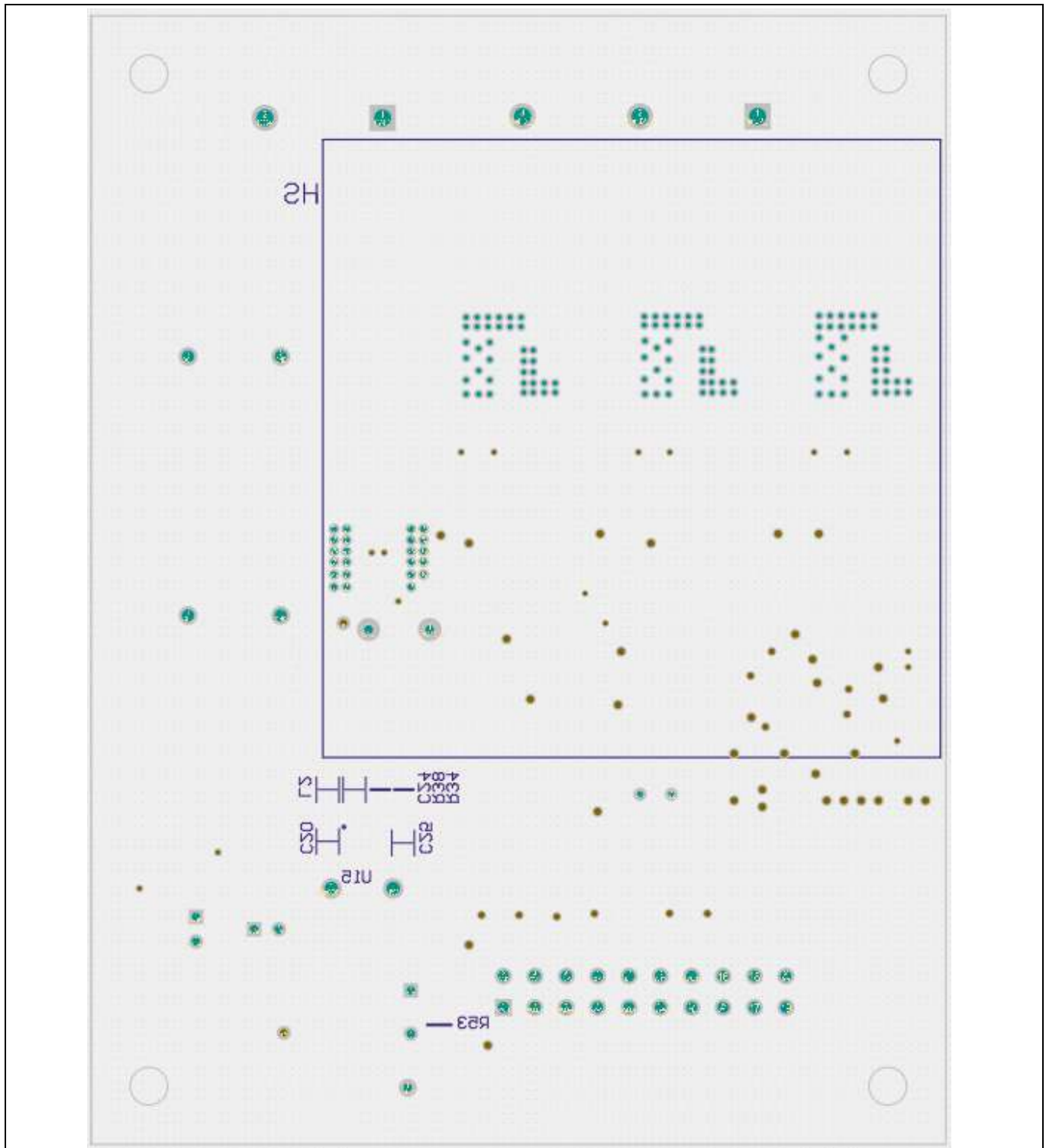

Figure 33 Bottom over layer

3.9 Bill of material

The complete bill of material is available on the download section of the Infineon homepage. A log-in is required to download this material. Table 5 is key components for this board.

Table 5 BOM of the most important/critical parts of EVAL-M1-05F310R

S. No.	Ref Designator	Description	Manufacturer	Manufacturer P/N
1	U1, U2, U3	CIPOS™ Nano	Infineon	IRSM005-301MH
2	U14	CoolSET™	Infineon	ICE5GR4780AG
3	D1, D2, D3, D7, D8, D9, D10, D11	Diode	Infineon	BAS3005A-02V
4	C1, C2	Electrolytic capacitor	Würth Elektronik	860240981008
5	L1	Magnetic-core inductor	Würth Elektronik	744731102
6	L2	Magnetic-core inductor	Würth Elektronik	74479777310A
7	R16	Shunt resistance		5 mΩ
8	R50	NPT		NXRT-5WF-100k 1%

3.10 Connector details

General information about the connectors of the EVAL-M1-05F310R evaluation board is provided in the tables below. Table 6 includes details of the DC input connector J1. Table 7 provides details of the motor side connector J2. Table 8 provides the pin assignments of the iMOTION™ MADK-M1 20-pin interface connector J3. This connector is the interface to the control board.

Table 6 J1 – DC input connector

Pin	Name	Details
1	DC+	DC+ connection
2	DC-	DC- connection

Table 7 J2- Motor side connector

Pin	Name	Details
1	U	Connect to motor phase U
2	V	Connect to motor phase V
3	W	Connect to motor phase W

Table 8 J3- iMOTION™ MADK-M1 20-pin interface connector to the control board

Pin	Name	Description
1	PWMUH	3.3 V compatible logic input for high side gate driver-phase U
2	GND	Ground
3	PWMUL	3.3 V compatible logic input for low side gate driver-phase U
4	GND	Ground
5	PWMVH	3.3 V compatible logic input for high side gate driver-phase V

System design

Pin	Name	Description
6	+3.3V	3.3 V power supply
7	PWMVL	3.3 V compatible logic input for low side gate driver-phase V
8	+3.3V	3.3 V power supply
9	PWMWH	3.3 V compatible logic input for high side gate driver-phase W
10	IU+	Shunt voltage+
11	PWMWL	3.3 V compatible logic input for low side gate driver-phase W
12	IU-	Ground
13	GK	Gatekill
14	DCBSENSE	Input, DC bus voltage to AIN1 after 2Mohm registers
15	VTH	Input, voltage input of power module's temperature sense
16	IV+	OPEN
17	IV-	OPEN
18	IW+	OPEN
19	IW-	OPEN
20	VCC	Defined for 15 V power supply

4 System performance

4.1 Type working waveform at DC 48 V input

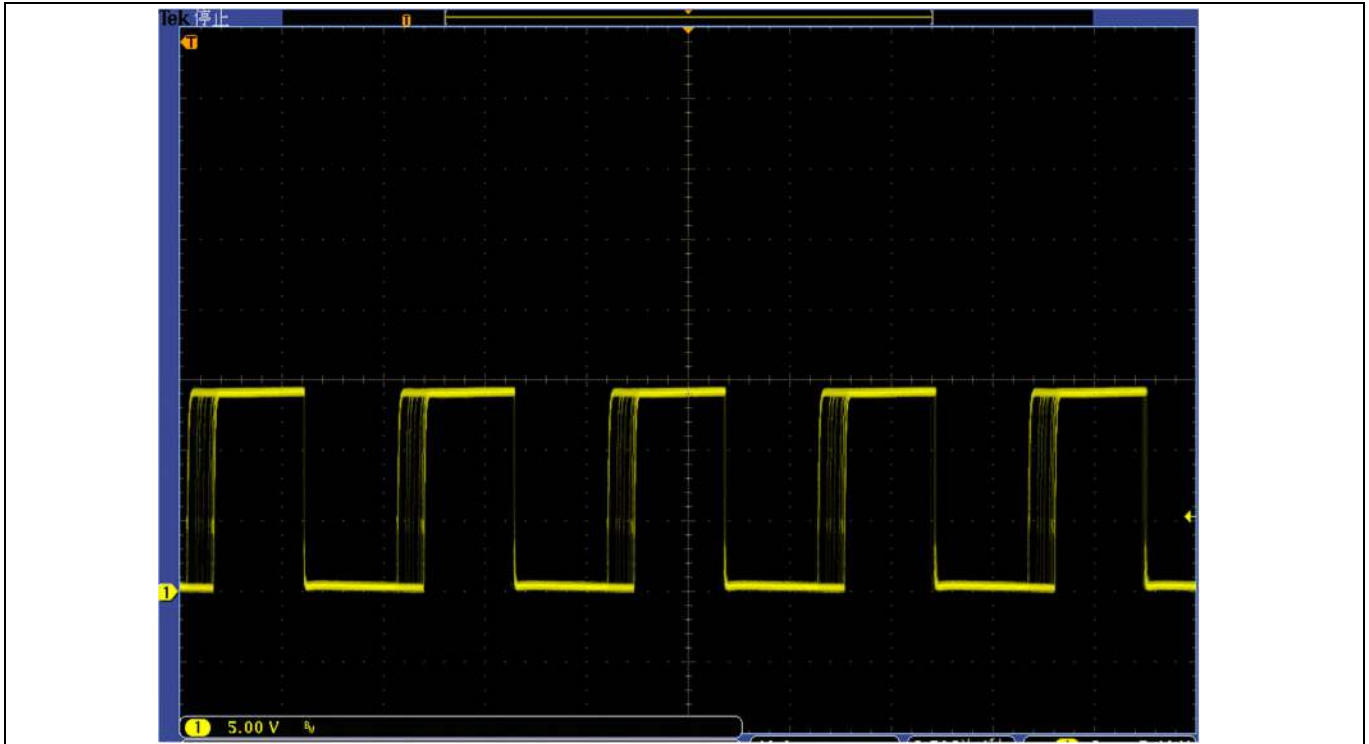

Figure 34 IRSM005-301MH gate drive

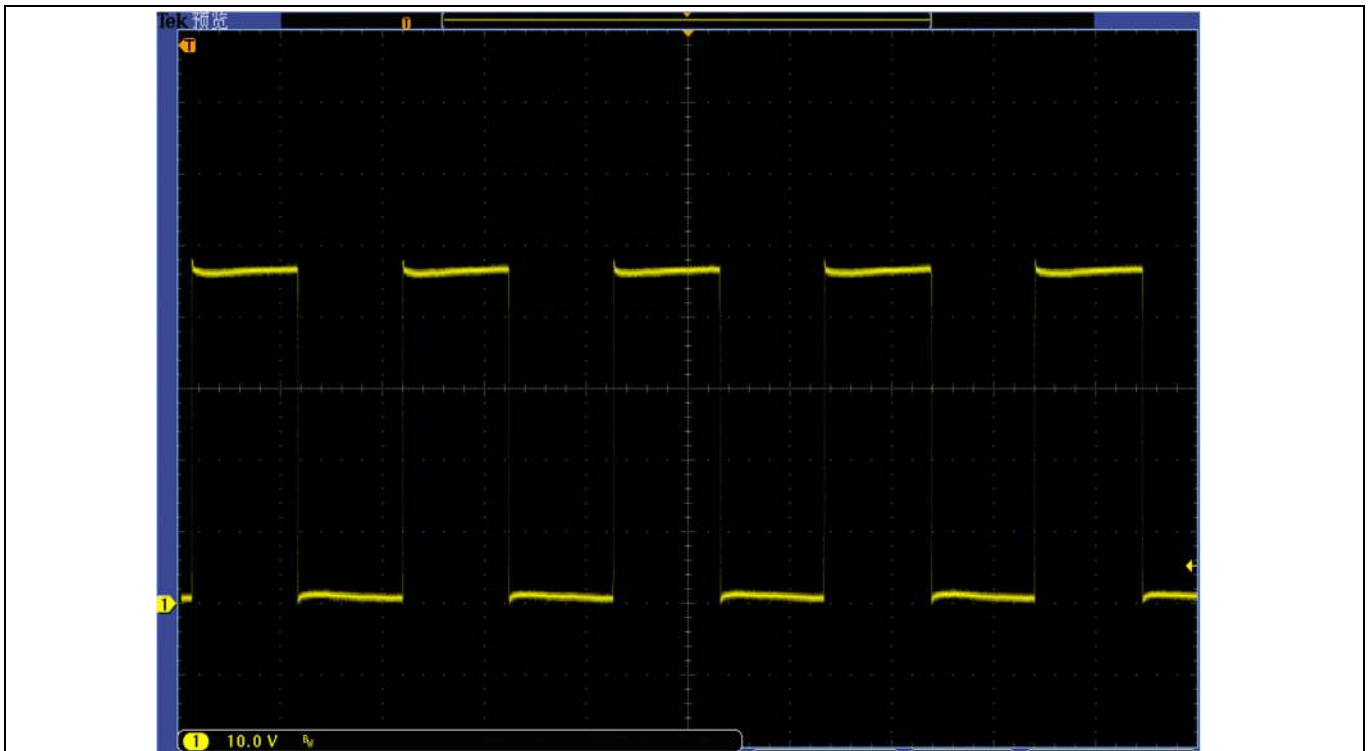

Figure 35 IRSM005-301MH PWM power output

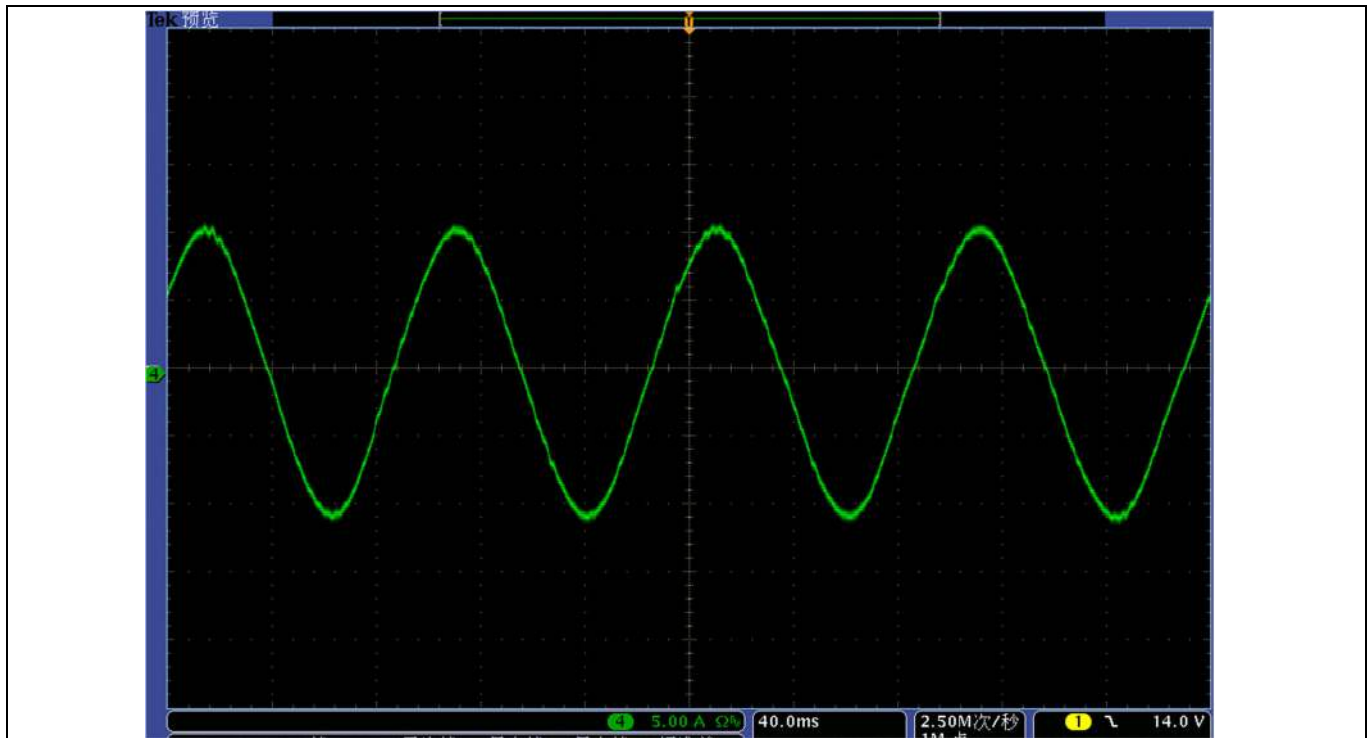

Figure 36 I_o output current @ DC 48 V, FPWM = 12 kHz

This is a typical sinusoidal current waveform of a brushless motor from the EVAL-M1-05F310R + EVAL-M1-101T with iMOTION™ software.

4.2 T_{cmaxi} vs I_{out} at different PWM frequencies

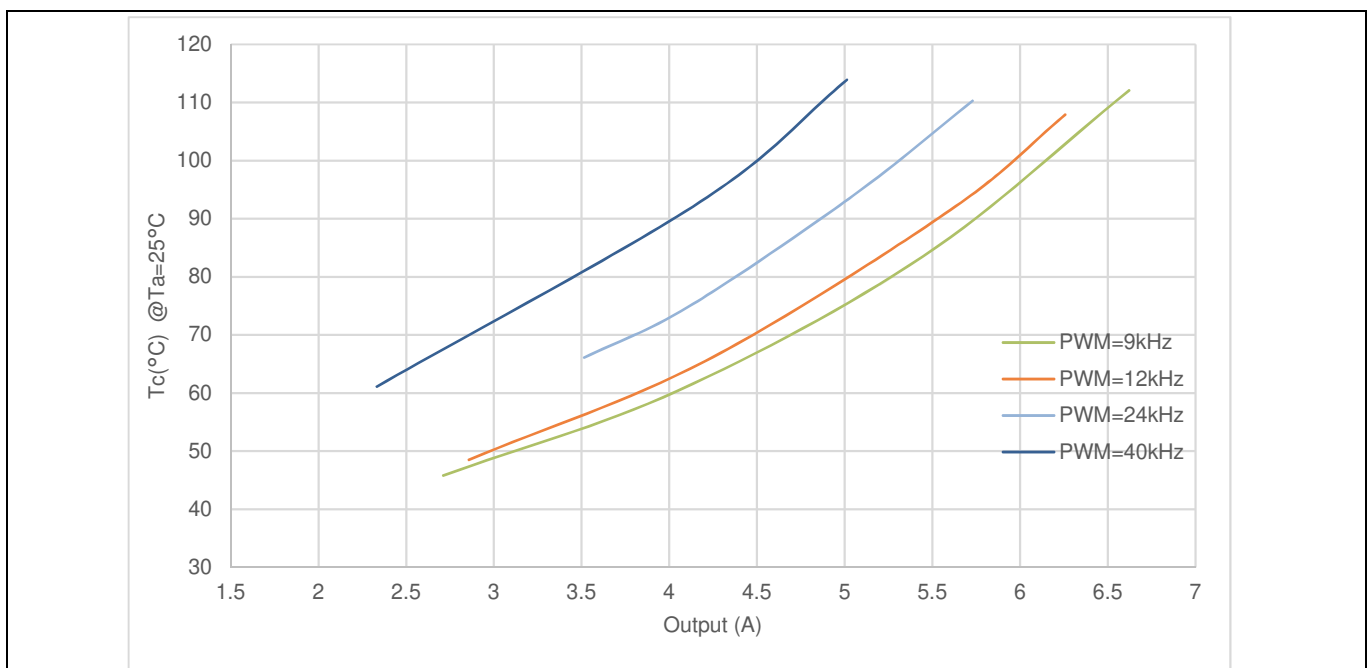

Figure 37 IRSM005F301MH case temperature vs output current with different PWM frequency (at 48 VDC, $T_a=25^\circ\text{C}$)

System performance

4.3 Options for cooling

EVAL-M1-05F310R has three cooling options for easy configuration and extending to higher power applications.

1. Self-cooling (default)
2. Heat-sink cooling
3. Fan cooling

4.3.1 Self-cooling

IRSM005-301MH is the double-sided cooling on the PCB done by copper and vias. For 0~6.2 A loading (input: DC 48 V, $f_{PWM}=9$ kHz, $T_a=25^\circ\text{C}$, $T_c \leq 100^\circ\text{C}$), the EVAL-M1-05F310R can operate well with PCB copper heat dissipation, and does not need an additional heat sink.

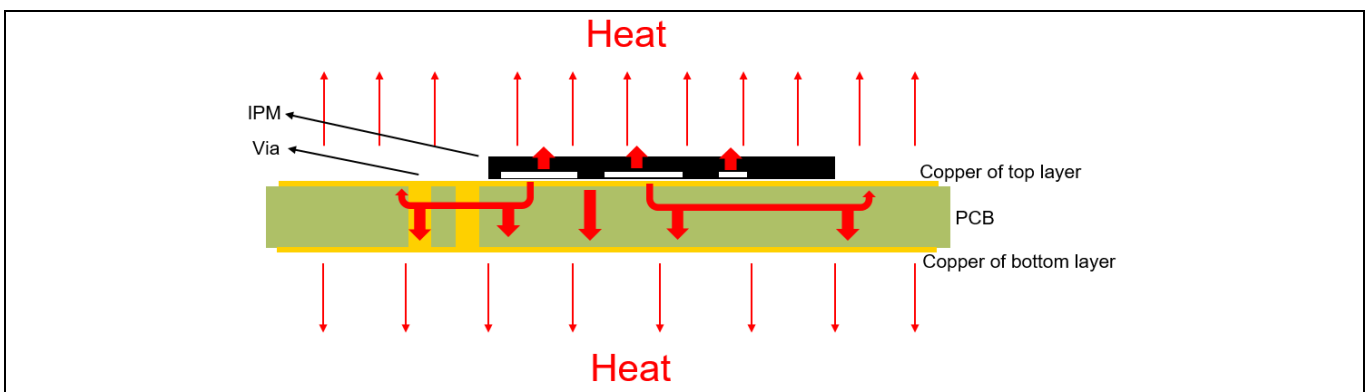

Figure 38 IRSM005-301MH heat conduction and cooling by two layers PCB copper

4.3.2 Heat-sink cooling

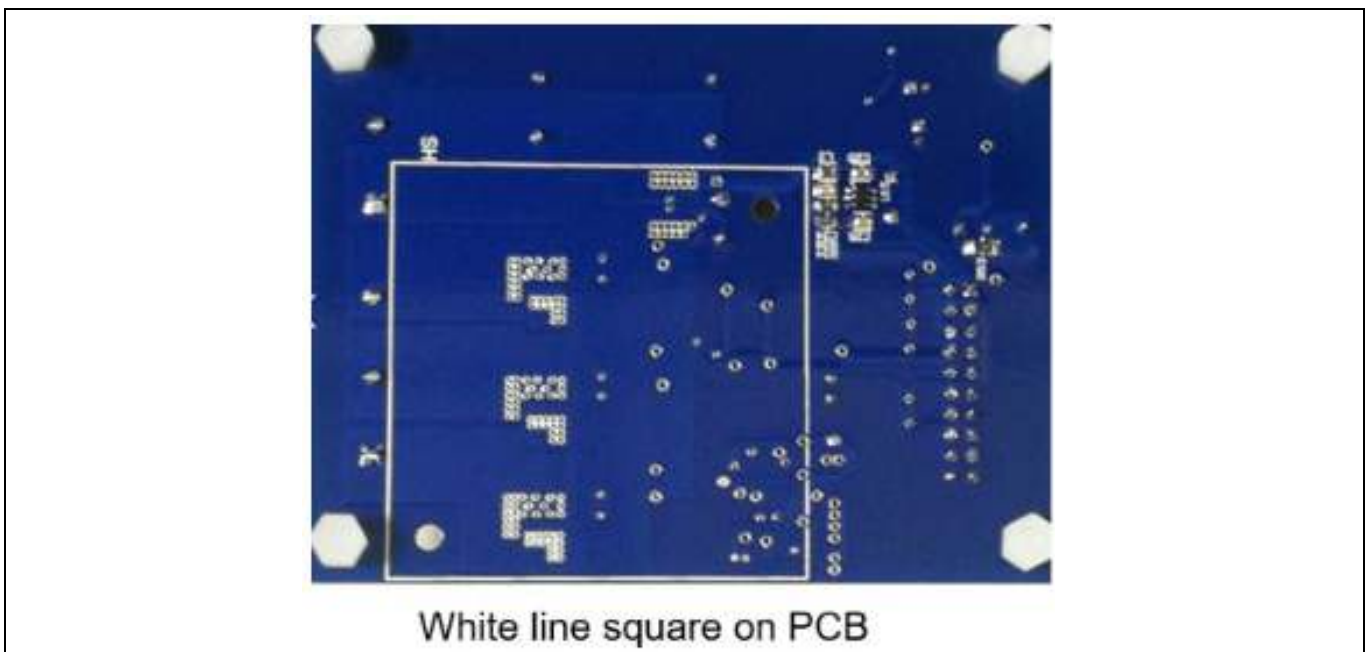

Figure 39 White lined square of installed heat sink

EVAL-M1-05F310R user guide

Modular application design kit (MADK) of IRSM005-301MH

System performance

This evaluation board reserves space for mounting an additional heat sink to extend output power. Figure 16 shows how to mount the heat sink. Please note the isolation thermal pad is required to isolate the PCB circuit to heat sink.

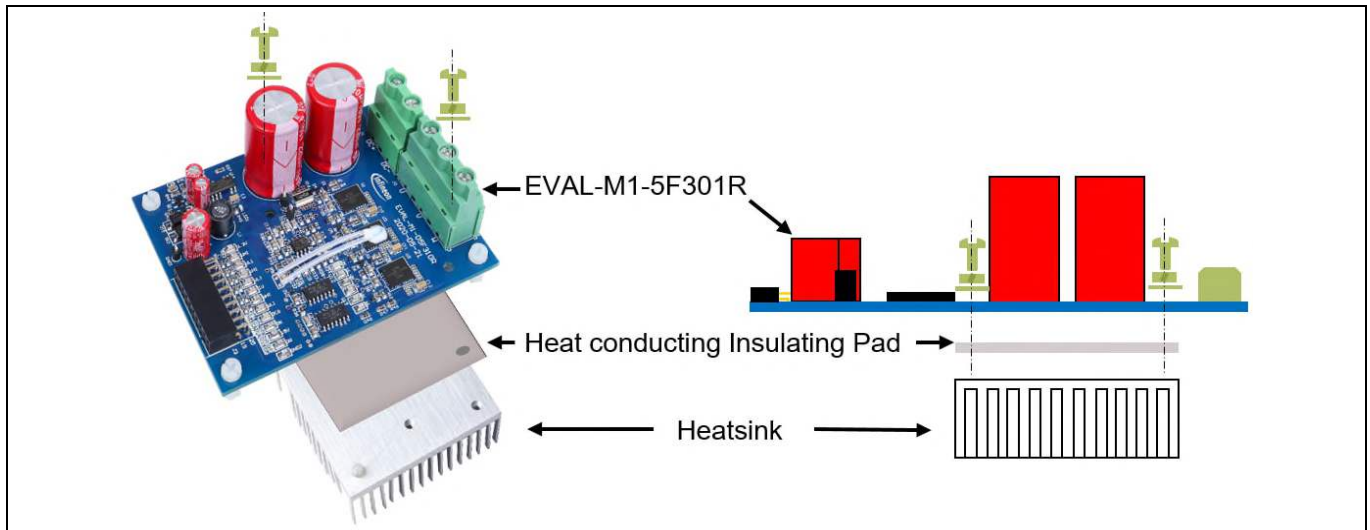

Figure 40 Instruction for heat sink installation

Note:

1. Heat sink size: $\leq 50 \text{ mm}(L) \times 50 \text{ mm}(W)$
2. Insulating thermal pad: $\geq 50 \text{ mm} \times 50 \text{ mm} \times 0.5 \text{ mm}$
3. Remove test point: CS+, CS-
4. Screw: M3 \times 10

4.3.3 Fan cooling

Whether in self-cooling or heat sink mode, EVAL-M1-05F310R supports additional fan cooling.

In the fan cooling mode, please set up Tc limited lower than 85°C so as not to overheat the MOSFET.

5 References and appendices

5.1 Abbreviations and definitions

Table 9 Abbreviations

Abbreviation	Meaning
MADK	Modular application design kit
OPA	Operational amplifier
LPF	Low-pass filter
SPWM	Sinusoidal pulse width modulation
CE	Conformité Européenne
EMI	Electromagnetic interference
UL	Underwriters Laboratories

5.2 References

- [1] Infineon Technologies AG. Datasheet of Infineon IPM IRSM005-301MH Datasheet (2020), V2.3 www.infineon.com
- [2] Infineon Technologies AG. Datasheet of Infineon IMC101T Datasheet (2020). V1.6 www.infineon.com.

5.3 Additional information

The power board is now available for customers in small order quantities. In order to initiate the testing, customers are advised to order the following items:

Table 10 Ordering information

Part number	Symbol	Package	Quantity
EVAL-M1-05F310R		Boxed	1
IRSM005-301MH	U1, U2, U3	IFX-PQFN-7x8	3
ICE5GR4780AG	U14	PG-DSO-12	1
BAS3005A-02V	D1, D2, D3, D7, D8, D9, D10, D11	INF-SC79_V	8



Revision history

Document version	Date of release	Description of changes
1.0	2020-11-10	First release

Trademarks

All referenced product or service names and trademarks are the property of their respective owners.

Edition 2020-11-10

Published by

Infineon Technologies AG

81726 Munich, Germany

© 2020 Infineon Technologies AG.

All Rights Reserved.

Do you have a question about this document?

Email: erratum@infineon.com

Document reference

UG-2020-24

For further information on the product, technology, delivery terms and conditions and prices please contact your nearest Infineon Technologies office (www.infineon.com).

WARNINGS

Due to technical requirements products may contain dangerous substances. For information on the types in question please contact your nearest Infineon Technologies office.

Except as otherwise explicitly approved by Infineon Technologies in a written document signed by authorized representatives of Infineon Technologies, Infineon Technologies' products may not be used in any applications where a failure of the product or any consequences of the use thereof can reasonably be expected to result in personal injury.