

NOTES:

1. MATERIALS AND FINISHES:  
 BODY - BRASS, GOLD PLATING  
 CONTACT - BeCu, GOLD PLATING  
 INSULATOR - PTFE, NATURAL
2. ELECTRICAL:  
 A. IMPEDANCE: 50 OHM  
 B. FREQUENCY RANGE: DC-6 GHz  
 C. VSWR(RETURN LOSS): 1.05 + 0.015 x F(GHz) MAX.  
 D. DIELECTRIC WITHSTANDING VOLTAGE: 1000 VRMS, MIN.
3. MECHANICAL:  
 A. DURABILITY: 500 CYCLES MIN.  
 B. TEMPERATURE RANGE: -55°C TO +155°C
4. PACKAGING:  
 A. QUANTITY: TRAY PACK  
 B. MARKING: PACKAGING TO BE MARKED  
 "AMPHENOL RF, 919-431J-51S, DATE CODE"

REVISIONS				
REV	DESCRIPTION	DATE	ECN	APPR
A	RELEASE TO MFG.	29-MAY-20	15189	S.HSIEH

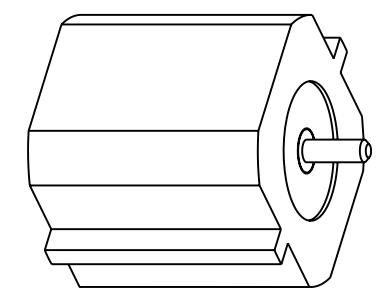

SCALE 6.000

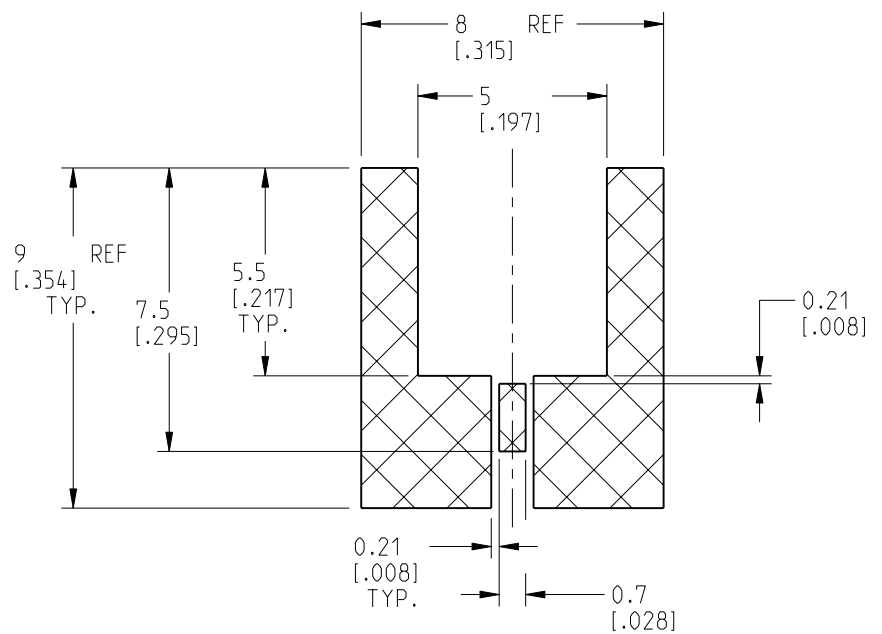

**RECOMMENDED PCB LAYOUT**  
 SOLDER FOOTPRINT ONLY.  
 PERFORMANCE WILL VARY  
 BASED ON BOARD LAYOUT

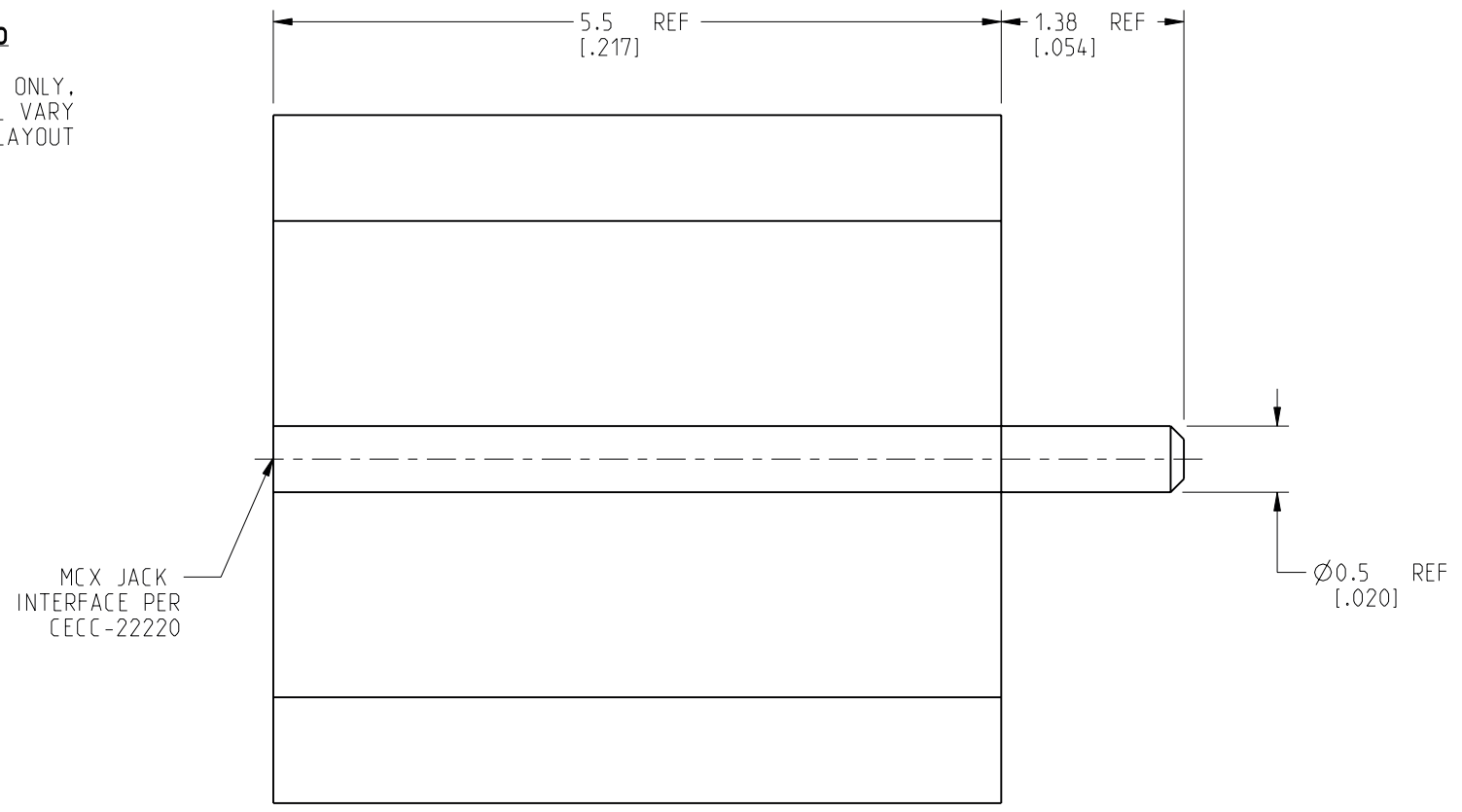
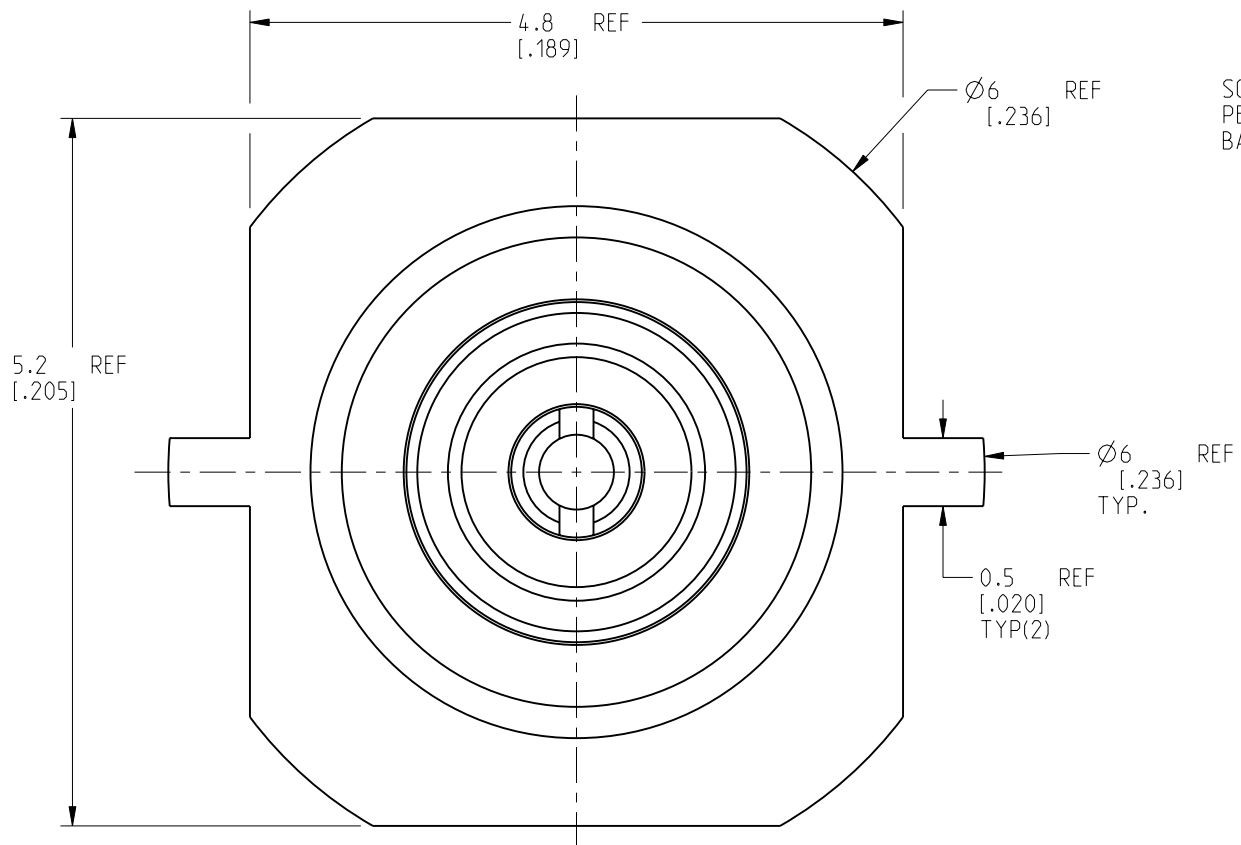

**CUSTOMER OUTLINE DRAWING**  
 ALL OTHER SHEETS ARE FOR INTERNAL USE ONLY

NOTICE: These drawings, specifications, or other data (1) are, and remain the property of Amphenol corp. (2) must be returned upon request; and (3) are confidential and not to be disclosed to any person other than those to whom they are given by Amphenol Corp. The furnishing of these drawings, specifications, or other data by Amphenol Corp., or to any other person to anyone for any purpose is not to be regarded by implication or otherwise in any manner licensing, granting rights to permitting such holder or any other person to manufacture, use or sell any product, process or design, patented or otherwise, that may in any way be related to or disclosed by said drawings, specifications, or other data.

UNLESS OTHERWISE SPECIFIED  
 DIMENSIONS ARE METRIC (INCHES) AND TOLERANCES ARE:  
 <0.5mm = ±0.05mm [ $<0.020 = \pm 0.002$ ]  
 >0.5 - 6mm = ±0.1mm [ $>0.020 - 0.236 = \pm 0.004$ ]  
 >6.00 - 30mm = ±0.2mm [ $>0.236 - 1.181 = \pm 0.008$ ]  
 >30.00 - 120mm = ±0.3mm [ $>1.181 - 4.725 = \pm 0.012$ ]  
 ANGLES = ±1°

MATERIAL  
 SEE NOTES

ENGINEER  
 E.W.U

DATE  
 22-MAY-20

TITLE  
 MCX EDGECARD PCB  
 MOUNT JACK

SHEET NO. 2 OF 2

SCALE: 18.0:1.0

**Amphenol RF**

SIZE	DRAWING NO. 919-431J-51S	REV
	ITEM NO. 919-431J-51S	A
	PART NO. 919-431J-51S	