

# NCP1230A

## Low-Standby Power Soft Skip Mode Controller

The NCP1230A represents a major leap towards achieving low standby power in medium-to-high power Switched-Mode Power Supplies such as notebook adapters, off-line battery chargers and consumer electronics equipment. Housed in a compact 8-pin package (SO-8 or PDIP-7), the NCP1230A contains all needed control functionality to build a rugged and efficient power supply. The NCP1230A is a current mode controller with internal ramp compensation. Among the unique features offered by the NCP1230A is an event management scheme that can disable the front-end PFC circuit during standby, thus reducing the no load power consumption. The NCP1230A itself goes into soft skipping at light loads while limiting peak current (to 25% of nominal peak) so that no acoustic noise is generated. The NCP1230A has a high-voltage startup circuit that eliminates external components and reduces power consumption.

The NCP1230A also features an internal latching function that can be used for OVP protection. This latch is triggered by pulling the CS pin above 3.0 V and can only be reset by pulling  $V_{CC}$  to ground. True overload protection, internal 2.5 ms soft-start, internal leading edge blanking, internal frequency dithering for low EMI are some of the other important features offered by the NCP1230A.

### Features

- Current-Mode Operation with Internal Ramp Compensation
- Internal High-Voltage Startup Current Source for Loss-Less Startup
- Extremely Low No-Load Standby Power
- Soft Skip Mode at Low Peak Currents (Skip-Cycle)
- Direct Connection to PFC Controller for Improved No-Load Standby Power
- Internal 2.5 ms Soft-Start
- Internal Leading Edge Blanking
- Short-Circuit Protection Independent of Auxiliary Level
- Internal Frequency Dithering for Improved EMI Signature
- +500 mA/-800 mA Peak Current Drive Capability
- Available in Three Frequency Options: 65 kHz, 100 kHz, and 133 kHz
- Direct Optocoupler Connection
- SPICE Models Available for TRANSient and AC Analysis
- Pb-Free Packages are Available

### Typical Applications

- High Power AC-DC Adapters for Notebooks, etc.
- Offline Battery Chargers
- Set-Top Boxes Power Supplies, TV, Monitors, etc.



ON Semiconductor®

<http://onsemi.com>

### MARKING DIAGRAMS



SO-8 VHVIC  
D SUFFIX  
CASE 751

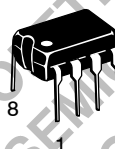
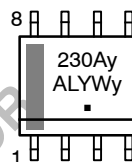

PDIP-7 VHVIC  
P SUFFIX  
CASE 626B

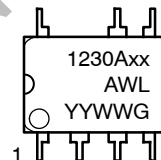

xx = Device Code: 65, 100, 133  
yy = Device Code: 65, 100, 133  
A = Assembly Location  
W, WW = Work Week  
L = Wafer Lot  
Y, YY = Year  
■ = Pb-Free Package  
G = Pb-Free Package

### PIN CONNECTIONS

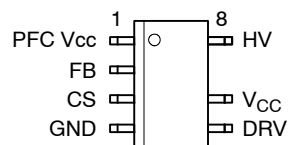

### ORDERING INFORMATION

See detailed ordering and shipping information in the package dimensions section on page 4 of this data sheet.

# NCP1230A

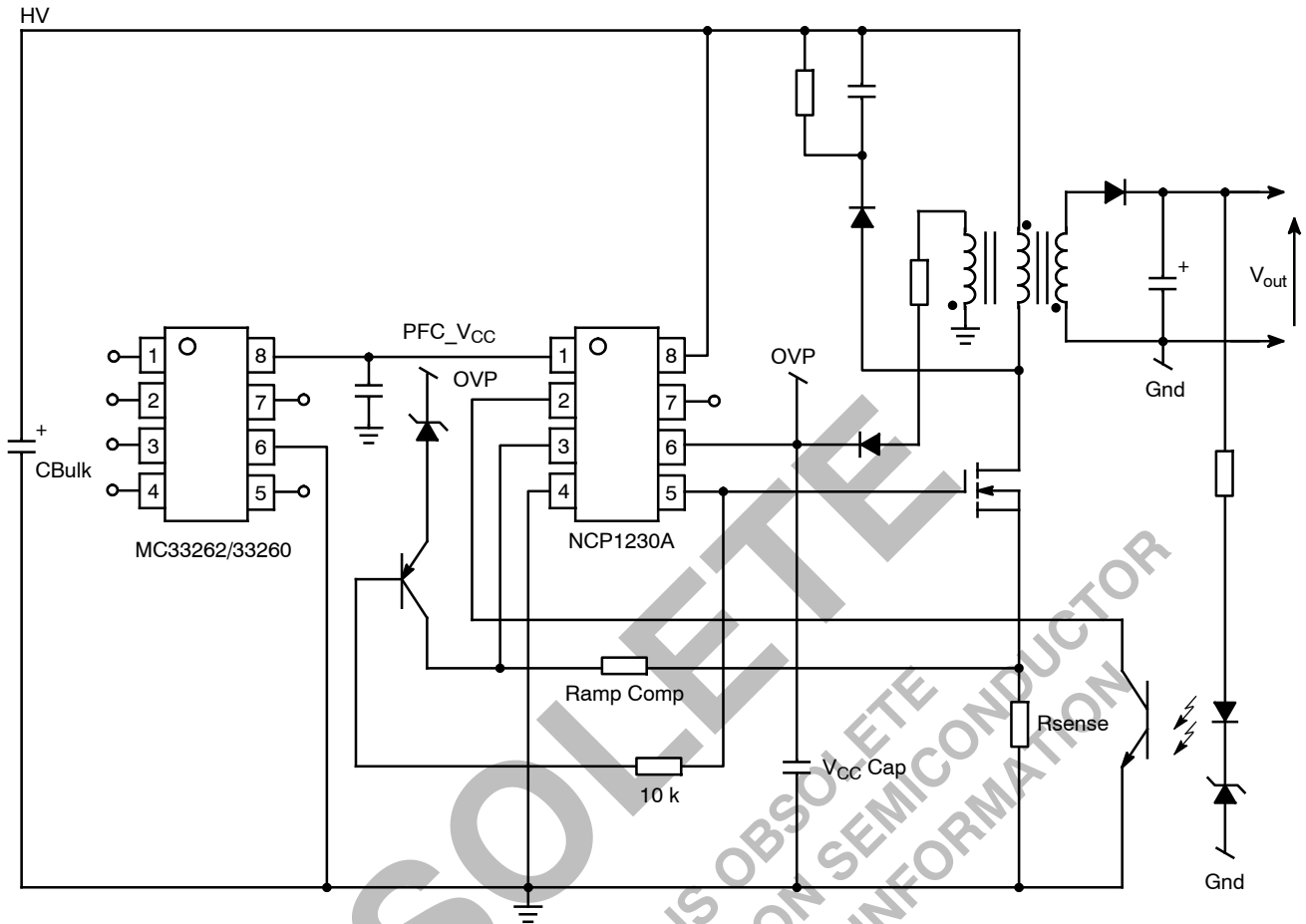

Figure 1. Typical Application Example

## PIN FUNCTION DESCRIPTION

Pin No.	Pin Name	Function	Pin Description
1	PFC V <sub>CC</sub>	This pin provides the bias voltage to the PFC controller.	This pin is a direct connection to the V <sub>CC</sub> pin (Pin 6) via a low impedance switch. In standby and during the startup sequence, the switch is open and the PFC V <sub>CC</sub> is shut down. As soon as the aux. winding is stabilized, Pin 1 connects to the V <sub>CC</sub> pin and provides bias to the PFC controller. It goes down in standby and fault conditions.
2	FB	Feedback Signal	An optocoupler collector pulls this pin low to regulate. When the current setpoint reaches 25% of the maximum peak, the controller skips cycles.
3	CS/OVP	Current Sense	This pin incorporates three different functions: the current sense function, an internal ramp compensation signal and a 3.0 V latch-off level which latches the output off until V <sub>CC</sub> is recycled.
4	GND	IC Ground	-
5	DRV	Driver Output	With a drive capability of +500 mA / -800 mA, the NCP1230A can drive large Qg MOSFETs.
6	V <sub>CC</sub>	V <sub>CC</sub> Input	The controller accepts voltages up to 18 V and features a UVLO turn-off threshold of 7.7 V typical.
7	NC	-	-
8	HV	High-Voltage	This pin connects to the bulk voltage and offers a lossless startup sequence. The charging current is high enough to support the bias needs of a PWM controller through Pin 1.

# NCP1230A

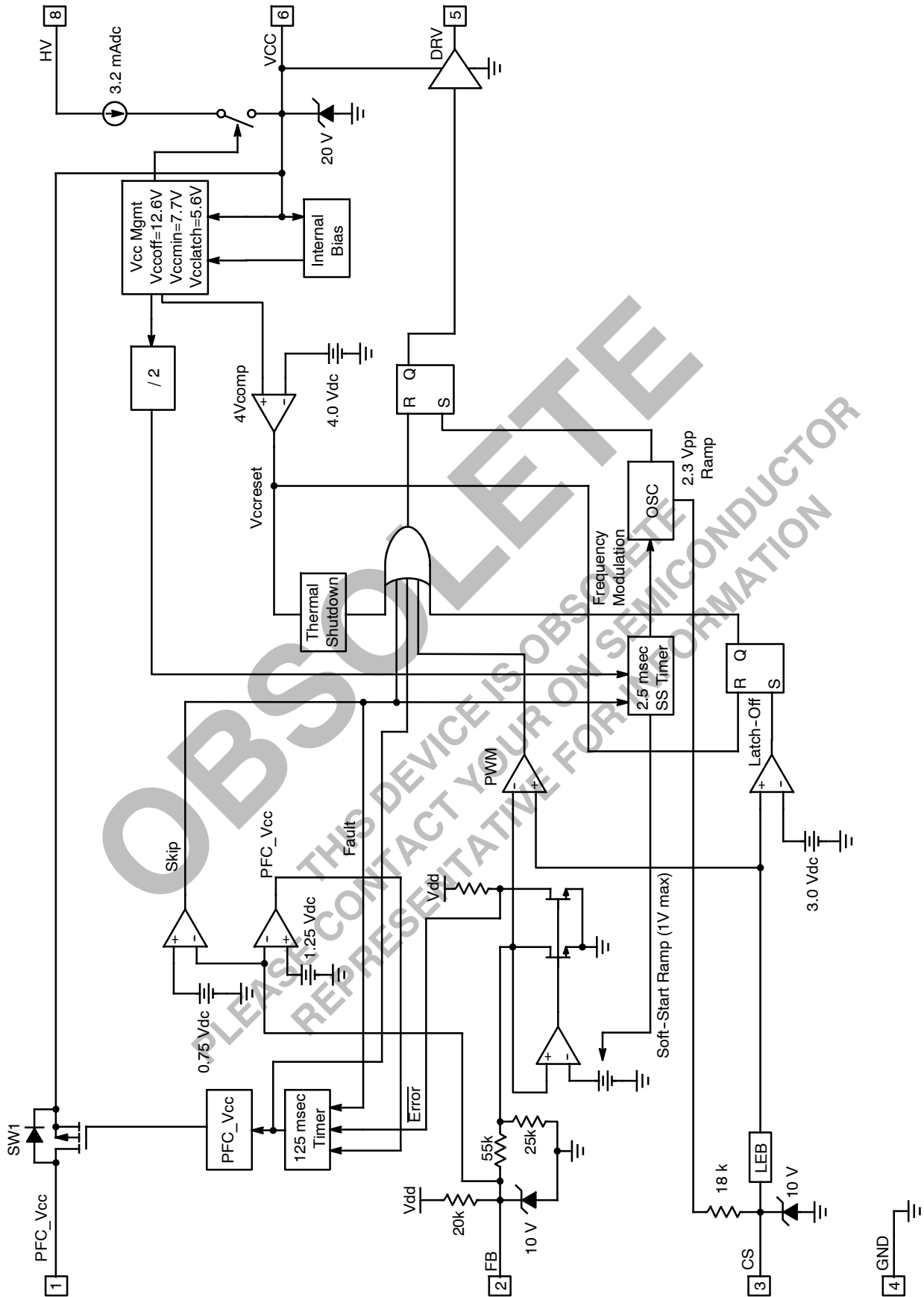

Figure 2. Internal Circuit Architecture

# NCP1230A

## MAXIMUM RATINGS (Notes 1 and 2)

Rating	Symbol	Value	Unit
Maximum Voltage on Pin 8 Maximum Current	$V_{DS}$ $I_{C2}$	-0.3 to 500 100	V mA
Power Supply Voltage, Pin 6 Current	$V_{CC}$ $I_{CC2}$	-0.3 to 18 100	V mA
Drive Output Voltage, Pin 5 Drive Current	$V_{DV}$ $I_o$	18 1.0	V A
Voltage Current Sense Pin, Pin 3 Current	$V_{cs}$ $I_{cs}$	10 100	V mA
Voltage Feedback, Pin 2 Current	$V_{fb}$ $I_{fb}$	10 100	V mA
Voltage, Pin 1 Maximum Continuous Current Flowing from Pin 1	$V_{PFC}$ $I_{PFC}$	18 35	V mA
Thermal Resistance, Junction-to-Air, PDIP Version	$R_{\theta JA}$	100	°C/W
Thermal Resistance, Junction-to-Air, SOIC Version	$R_{\theta JA}$	178	°C/W
Maximum Power Dissipation @ $T_A = 25^\circ\text{C}$	PDIP SOIC $P_{max}$	1.25 0.702	W
Maximum Junction Temperature	$T_J$	150	°C
Storage Temperature Range	$T_{stg}$	-60 to +150	°C

Stresses exceeding Maximum Ratings may damage the device. Maximum Ratings are stress ratings only. Functional operation above the Recommended Operating Conditions is not implied. Extended exposure to stresses above the Recommended Operating Conditions may affect device reliability.

- This device series contains ESD protection and exceeds the following tests:  
 Pin 1-6: Human Body Model 2000 V per Mil-Std-883, Method 3015.  
 Machine Model Method 200 V  
 Pin 8 is the HV startup of the device and is rated to the maximum rating of the part, or 500 V.
- This device contains latchup protection and exceeds 100 mA per JEDEC Standard JESD78.

## ORDERING INFORMATION

Device Order Number	Package Type	Tape and Reel Size†
NCP1230AD65R2	SO-8	2500 / Tape & Reel
NCP1230AD65R2G	SO-8 (Pb-Free)	2500 / Tape & Reel
NCP1230AD100R2	SO-8	2500 / Tape & Reel
NCP1230AD100R2G	SO-8 (Pb-Free)	2500 / Tape & Reel
NCP1230AD133R2	SO-8	2500 / Tape & Reel
NCP1230AD133R2G	SO-8 (Pb-Free)	2500 / Tape & Reel
NCP1230AP65	PDIP-7	50 Units / Rail
NCP1230AP65G	PDIP-7 (Pb-Free)	50 Units / Rail
NCP1230AP100	PDIP-7	50 Units / Rail
NCP1230AP100G	PDIP-7 (Pb-Free)	50 Units / Rail
NCP1230AP133	PDIP-7	50 Units / Rail
NCP1230AP133G	PDIP-7 (Pb-Free)	50 Units / Rail

†For information on tape and reel specifications, including part orientation and tape sizes, please refer to our Tape and Reel Packaging Specifications Brochure, BRD8011/D.

# NCP1230A

**ELECTRICAL CHARACTERISTICS** (For typical values  $T_J = 25^\circ\text{C}$ , for min/max values  $T_J = -40^\circ\text{C}$  to  $+125^\circ\text{C}$ , Max  $T_J = 150^\circ\text{C}$ ,  $V_{CC} = 13\text{ V}$ ,  $V_{PIN8} = 30\text{ V}$  unless otherwise noted.)

Characteristic	Symbol	Pin	Min	Typ	Max	Unit
----------------	--------	-----	-----	-----	-----	------

## Supply Section (All frequency versions, otherwise noted)

Turn-On Threshold Level, $V_{CC}$ Going Up ( $V_{fb} = 2.0\text{ V}$ )	$V_{CCOFF}$	6	11.6	12.6	13.6	V
Minimum Operating Voltage after Turn-On	$V_{CC(min)}$	6	7.0	7.7	8.4	V
$V_{CC}$ Decreasing Level at which the Latch-Off Phase Ends ( $V_{fb} = 3.5\text{ V}$ )	$V_{CClatch}$	6	5.0	5.6	6.2	V
$V_{CC}$ Level at which the Internal Logic gets Reset	$V_{CCreset}$	6	-	4.0	-	V
Internal IC Consumption, No Output Load on Pin 6 ( $V_{fb} = 2.5\text{ V}$ )	$I_{CC1}$	6	0.6	1.1	1.8	mA
Internal IC Consumption, 1.0 nF Output Load on Pin 6, $F_{SW} = 65\text{ kHz}$ ( $V_{fb} = 2.5\text{ V}$ )	$I_{CC2}$	6	1.3	1.8	2.5	mA
Internal IC Consumption, 1.0 nF Output Load on Pin 6, $F_{SW} = 100\text{ kHz}$	$I_{CC2}$	6	1.3	2.2	3.0	mA
Internal IC Consumption, 1.0 nF Output Load on Pin 6, $F_{SW} = 133\text{ kHz}$	$I_{CC2}$	6	1.3	2.8	3.3	mA
Internal IC Consumption, Latch-Off Phase	$I_{CC3}$	6	400	680	1000	$\mu\text{A}$

## Internal Startup Current Source

High-Voltage Current Source, 1.0 nF Load ( $V_{CCOFF} = -0.2\text{ V}$ , $V_{fb} = 2.5\text{ V}$ , $V_{PIN8} = 30\text{ V}$ )	$I_{C1}$	8	1.8	3.2	4.2	mA
High-Voltage Current Source ( $V_{CC} = 0\text{ V}$ )	$I_{C2}$	8	1.8	4.4	5.6	mA
Minimum Startup Voltage ( $I_C = 0.5\text{ mA}$ , $V_{CCOFF} = -0.2\text{ V}$ , $V_{fb} = 2.5\text{ V}$ )	$V_{HVmin}$	8	-	20	23	V
Startup Leakage	$I_{HVLeak}$	8	10	30	80	$\mu\text{A}$

## Drive Output

Output Voltage Rise-Time @ $C_L = 1.0\text{ nF}$ , 10-90% of Output Signal	$T_r$	5	-	40	-	ns
Output Voltage Fall-Time @ $C_L = 1.0\text{ nF}$ , 10-90% of Output Signal	$T_f$	5	-	15	-	ns
Source Resistance, $R_{Load} = 300\ \Omega$ ( $V_{fb} = 2.5\text{ V}$ )	$R_{OH}$	5	6.0	12.3	25	$\Omega$
Sink Resistance, at 1.0 V on Pin 5 ( $V_{fb} = 3.5\text{ V}$ )	$R_{OL}$	5	3.0	7.5	18	$\Omega$
Pin 1 Output Impedance (or $R_{dson}$ between Pin 1 and Pin 6 when SW1 is closed) $R_{load}$ on Pin 1 = $680\ \Omega$	RPFC	1	6.0	11.7	23	$\Omega$

## Current Comparator and Thermal Shutdown

Input Bias Current @ 1.0 V Input Level on Pin 3	$I_{IB}$	3	-	0.02	-	$\mu\text{A}$
Maximum Internal Current Setpoint $T_J = 25^\circ\text{C}$ $T_J = -40^\circ\text{C}$ to $+125^\circ\text{C}$	$I_{Limit}$	3	1.010 0.979	1.063 -	1.116 1.127	V
Default Internal Setpoint for Skip Cycle Operation and Standby Detection	$V_{skip}$	3	600	750	900	mV
Default Internal Setpoint to Leave Standby	$V_{stby-out}$	-	1.0	1.25	1.5	V
Propagation Delay from CS Detected to Gate Turned Off ( $V_{Gate} = 10\text{ V}$ ) (Pin 5 Loaded by 1.0 nF)	$T_{DEL\ CS}$	3	-	90	180	ns
Leading Edge Blanking Duration	$T_{LEB}$	3	100	200	350	ns
Soft-Start Period / Soft Skip Period (Note 3)	SS	-	-	2.5	-	ms
Temperature Shutdown, Maximum Value (Note 3)	$T_{SD}$	-	150	165	-	$^\circ\text{C}$
Hysteresis while in Temperature Shutdown (Note 3)	$T_{SD\ hyste}$	-	-	25	-	$^\circ\text{C}$

3. Verified by Design.

# NCP1230A

**ELECTRICAL CHARACTERISTICS** (For typical values  $T_J = 25^\circ\text{C}$ , for min/max values  $T_J = -40^\circ\text{C}$  to  $+125^\circ\text{C}$ , Max  $T_J = 150^\circ\text{C}$ ,  $V_{CC} = 13\text{ V}$ ,  $V_{PIN8} = 30\text{ V}$  unless otherwise noted.)

Characteristic	Symbol	Pin	Min	Typ	Max	Unit
<b>Internal Oscillator</b>						
Oscillation Frequency, 65 kHz Version ( $V_{fb} = 2.5\text{ V}$ ) $T_J = 25^\circ\text{C}$ $T_J = 0^\circ\text{C}$ to $+125^\circ\text{C}$ $T_J = -40^\circ\text{C}$ to $+125^\circ\text{C}$	$f_{osc}$	-	60 58 55	65 - -	70 72 72	kHz
Oscillation Frequency, 100 kHz Version $T_J = 25^\circ\text{C}$ $T_J = 0^\circ\text{C}$ to $+125^\circ\text{C}$ $T_J = -40^\circ\text{C}$ to $+125^\circ\text{C}$	$f_{osc}$	-	93 90 85	100 - -	107 110 110	kHz
Oscillation Frequency, 133 kHz Version $T_J = 25^\circ\text{C}$ $T_J = 0^\circ\text{C}$ to $+125^\circ\text{C}$ $T_J = -40^\circ\text{C}$ to $+125^\circ\text{C}$	$f_{osc}$	-	123 120 113	133 - -	143 146 146	kHz
Internal Modulation Swing, in Percentage of $F_{sw}$ ( $V_{fb} = 2.5\text{ V}$ ) (Note 4)	-	-	-	$\pm 6.4$	-	%
Internal Swing Period (Note 4)	-	-	-	5.0	-	ms
Maximum Duty-Cycle ( $CS = 0$ , $V_{fb} = 2.5\text{ V}$ )	$D_{max}$	-	75	80	85	%
<b>Internal Ramp Compensation</b>						
Internal Resistor (Note 4)	$R_{up}$	3	9.0	18	36	$k\Omega$
Ramp Compensation Sawtooth Amplitude	-	3	-	2.3	-	V <sub>pp</sub>
<b>Feedback Section</b>						
Opto Current Source ( $V_{fb} = 0.75\text{ V}$ )	-	2	200	235	270	$\mu\text{A}$
Pin 3 to Current Setpoint Division Ratio (Note 4)	$I_{ratio}$	-	-	2.8	-	-
<b>Protection</b>						
Timeout before Validating Short-Circuit or PFC $V_{CC}$ (Note 4)	$T_{delay}$	-	-	125	-	ms
Latch-Off Level	$V_{latch}$	3	2.7	3.0	3.3	V

4. Verified by Design.

TYPICAL PERFORMANCE CHARACTERISTICS

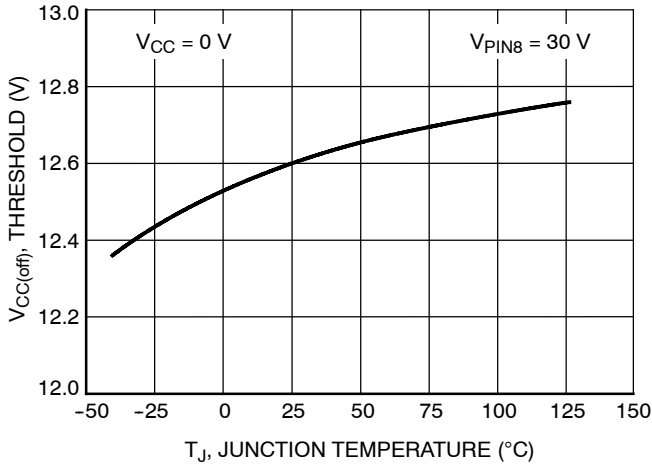

Figure 3. V<sub>CC(OFF)</sub> Threshold vs. Temperature

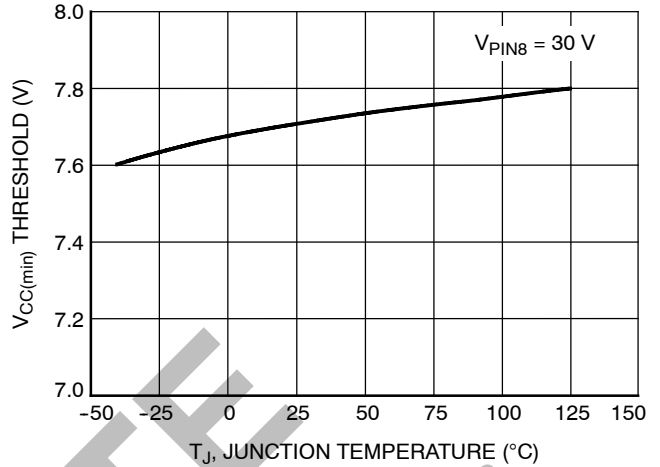

Figure 4. V<sub>CC(min)</sub> Threshold vs. Temperature

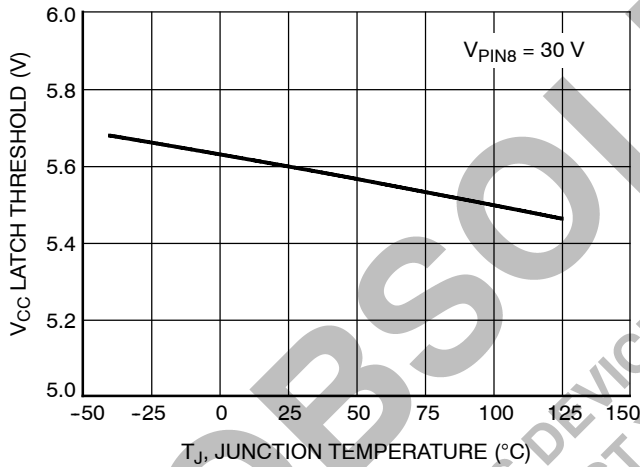

Figure 5. V<sub>CC</sub> Latch Threshold vs. Temperature

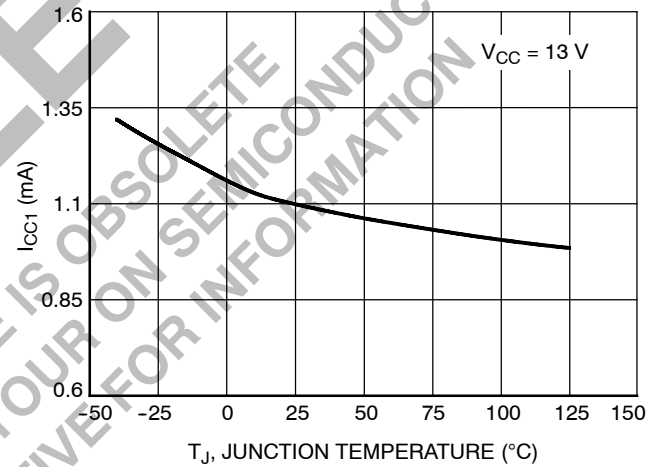

Figure 6. I<sub>CC1</sub> Internal Current Consumption, No Load vs. Temperature

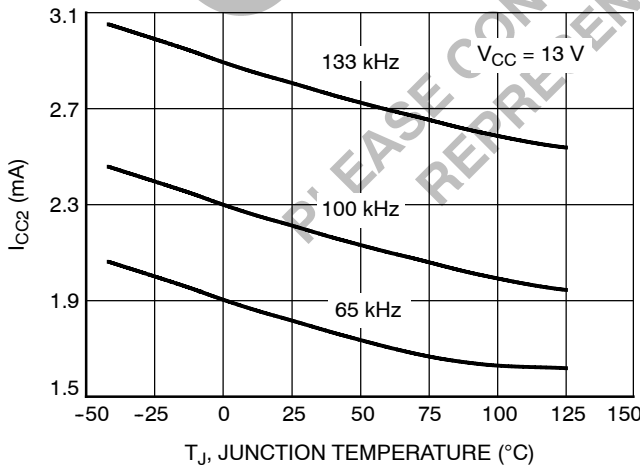

Figure 7. I<sub>CC2</sub> Internal Current Consumption, 1.0 nF Load vs. Temperature

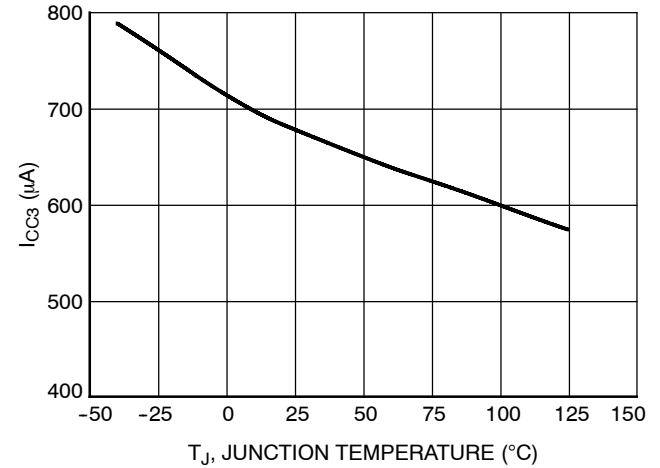

Figure 8. I<sub>CC3</sub> Internal Consumption, Latch-Off Phase vs. Temperature

# NCP1230A

## TYPICAL PERFORMANCE CHARACTERISTICS

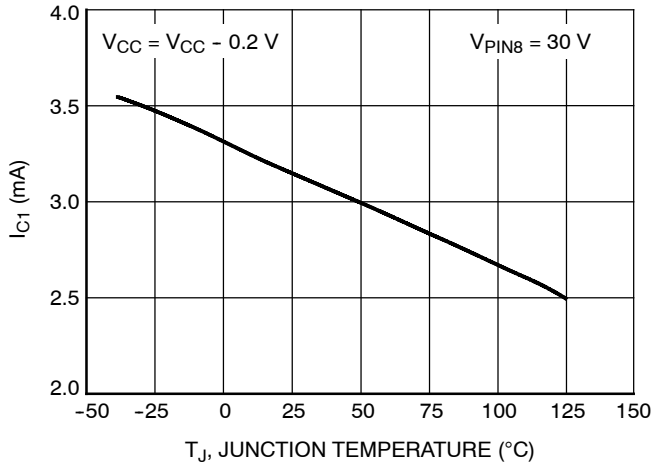

Figure 9. I<sub>C1</sub> Startup Current vs. Temperature

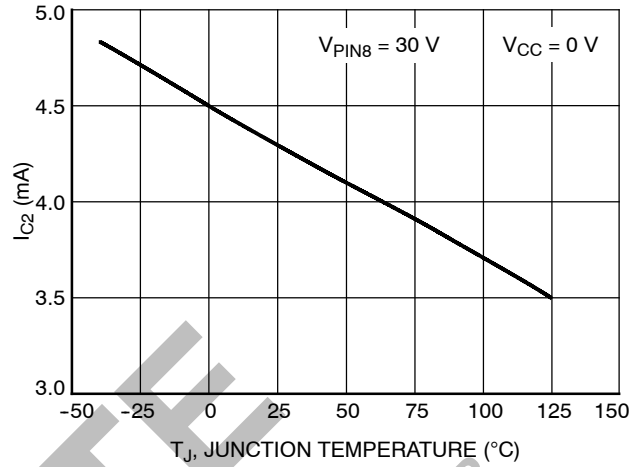

Figure 10. I<sub>C2</sub> Startup Current vs. Temperature

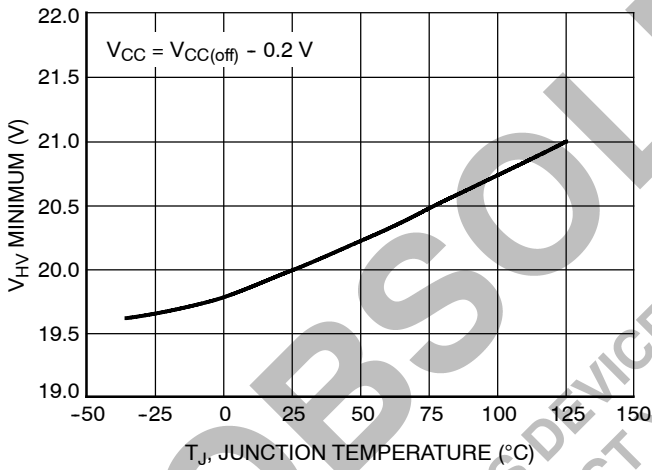

Figure 11. Minimum Startup Voltage vs. Temperature

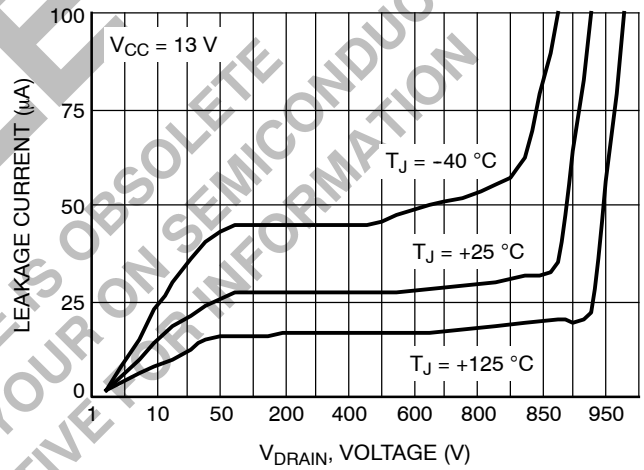

Figure 12. Leakage Current vs. Temperature

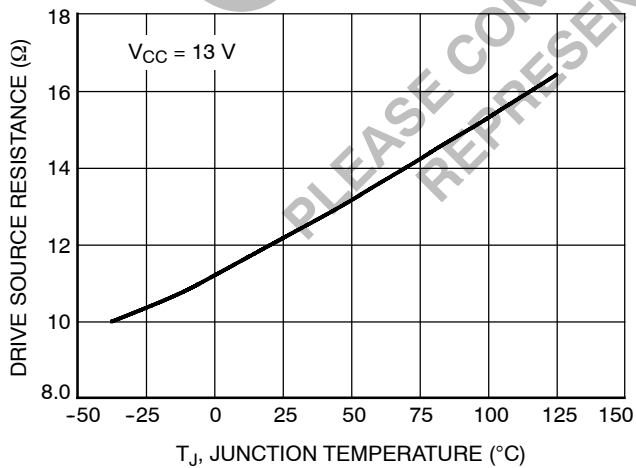

Figure 13. Drive Source Resistance vs. Temperature

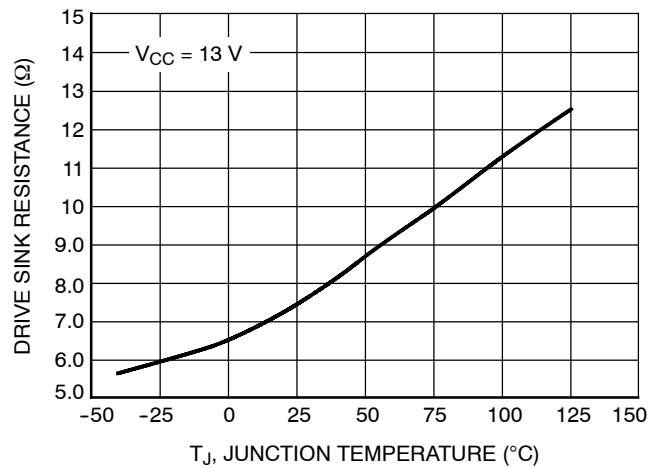

Figure 14. Drive Sink Resistance vs. Temperature



# NCP1230A

## TYPICAL PERFORMANCE CHARACTERISTICS

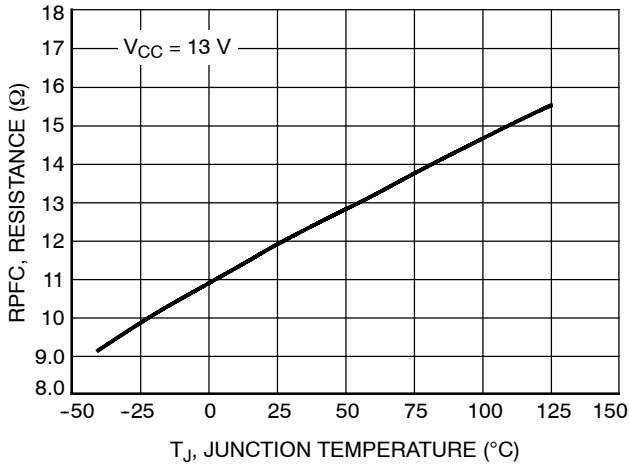

Figure 15. RPFC vs. Temperature

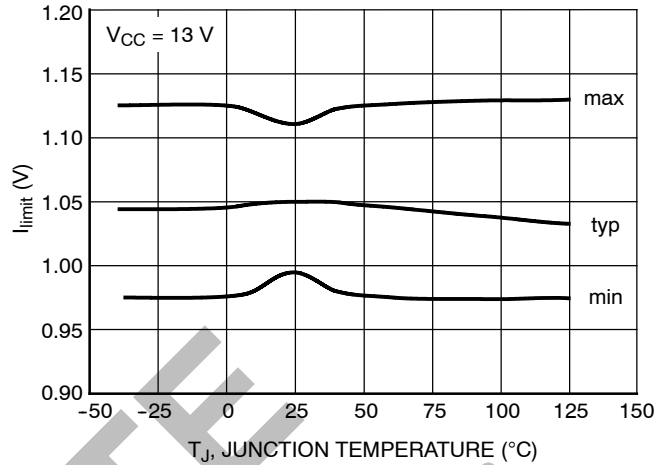

Figure 16. ILimit vs. Temperature

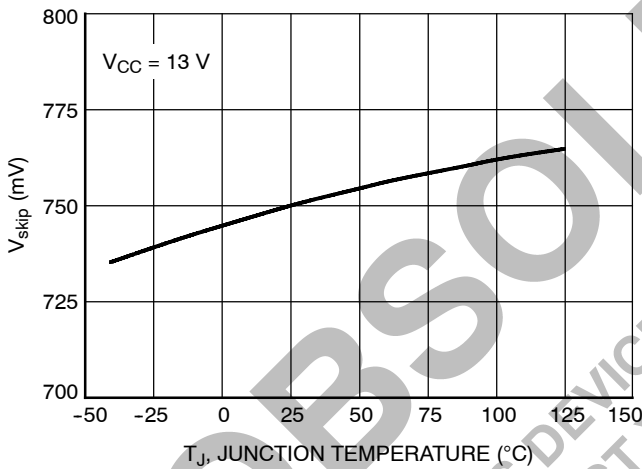

Figure 17. VSkip vs. Temperature

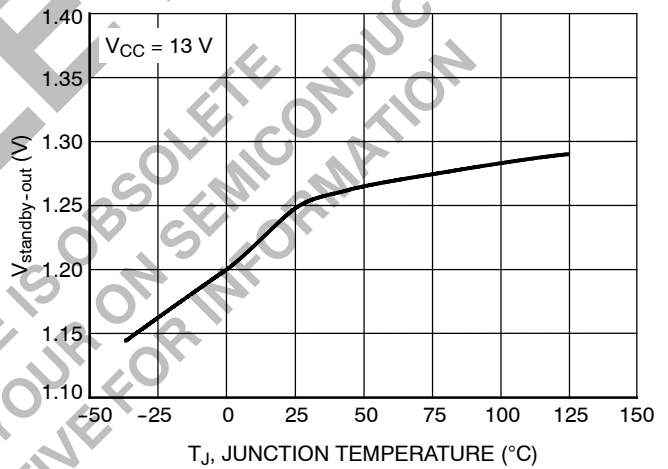

Figure 18. Vstby-out vs. Temperature

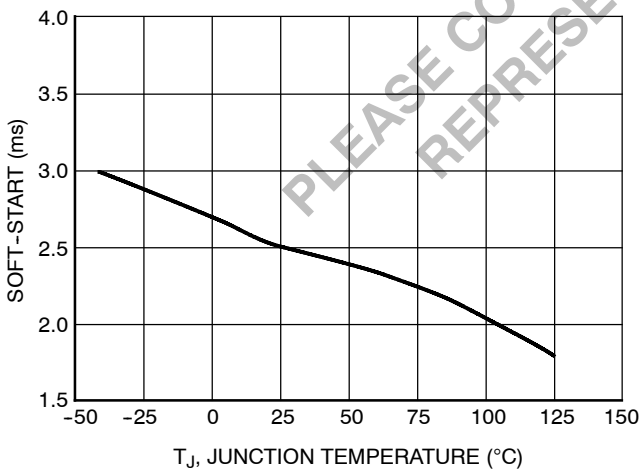

Figure 19. Soft-Start vs. Temperature

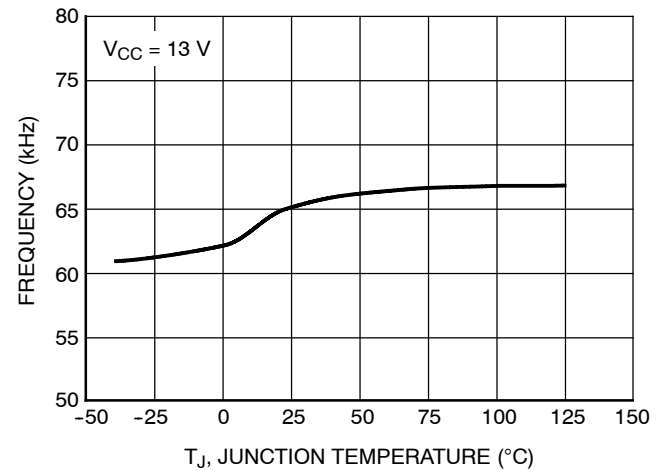

Figure 20. Frequency (65 kHz) vs. Temperature

TYPICAL PERFORMANCE CHARACTERISTICS

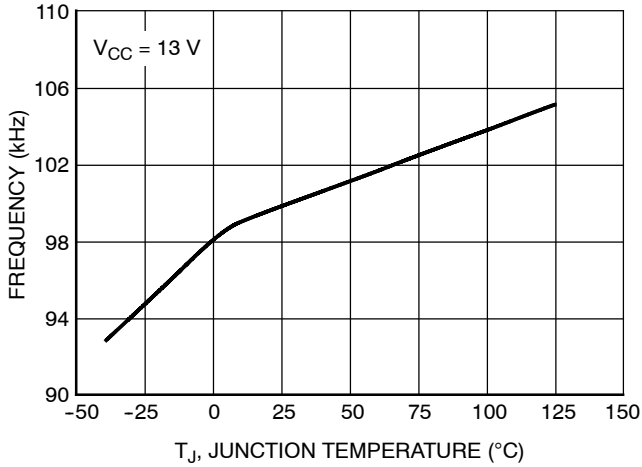

Figure 21. Frequency (100 kHz) vs. Temperature

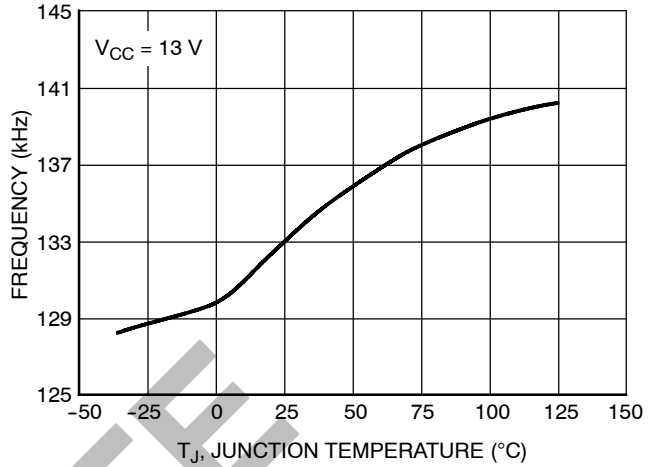

Figure 22. Frequency (133 kHz) vs. Temperature

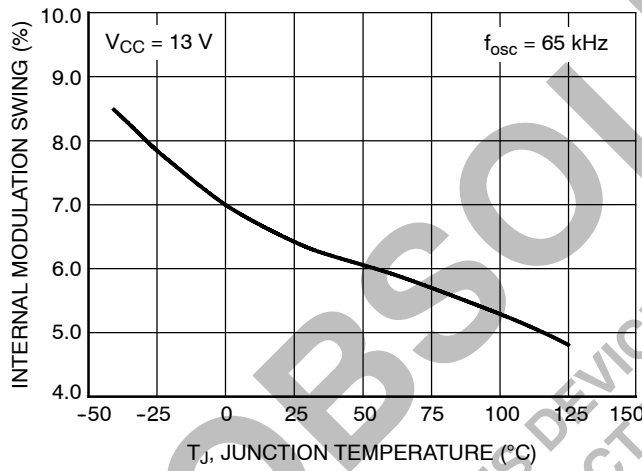

Figure 23. Internal Modulation Swing vs. Temperature

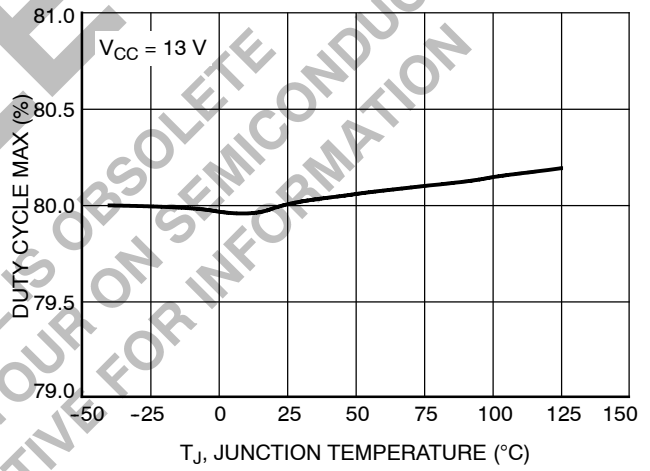

Figure 24. Maximum Duty Cycle vs. Temperature

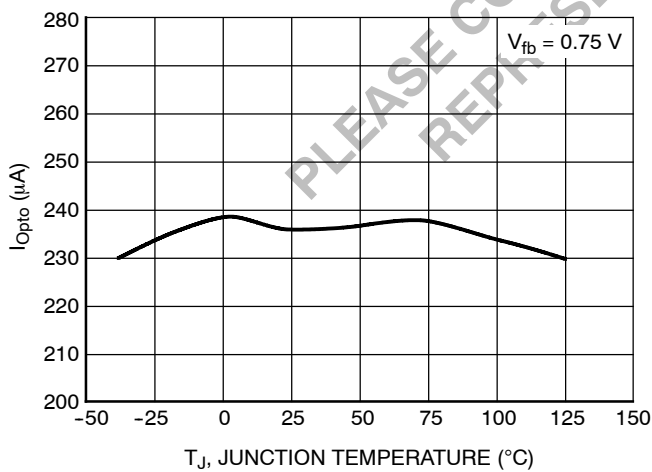

Figure 25. I<sub>opto</sub> vs. Temperature

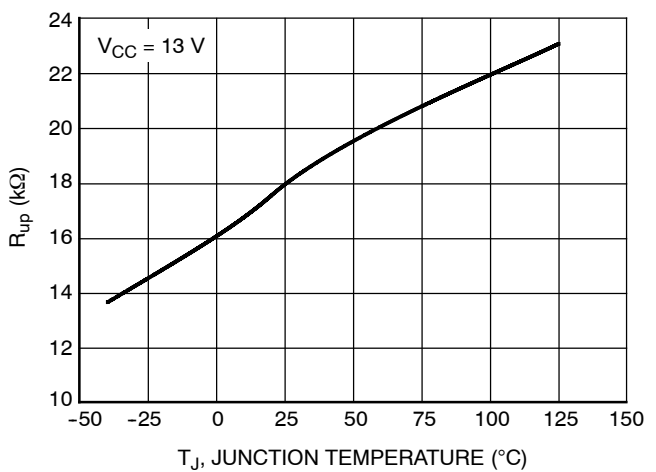

Figure 26. Internal Ramp Compensation Resistor vs. Temperature

# NCP1230A

## TYPICAL PERFORMANCE CHARACTERISTICS

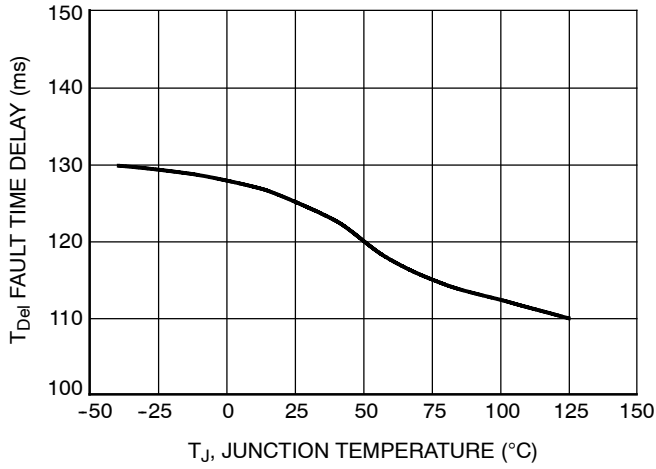

Figure 27. Fault Time Delay vs. Temperature

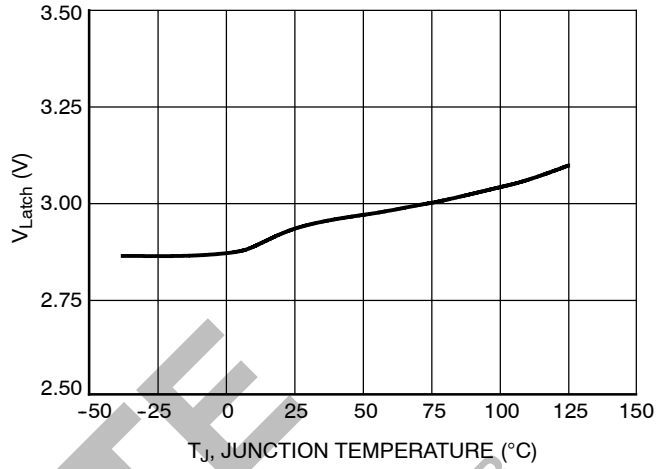

Figure 28.  $V_{Latch}$  vs. Temperature

**OBSOLETE**  
THIS DEVICE IS OBSOLETE  
PLEASE CONTACT YOUR ON SEMICONDUCTOR  
REPRESENTATIVE FOR INFORMATION

# NCP1230A

## OPERATING DESCRIPTION

### Introduction

The NCP1230A is a current mode controller which provides a high level of integration by providing all the required control logic, protection, and a PWM Drive Output into a single chip which is ideal for low cost, medium to high power off-line application, such as notebook adapters, battery chargers, set-boxes, TV, and computer monitors.

The NCP1230A can be connected directly to a high voltage source providing lossless startup, and eliminating external startup circuitry. In addition, the NCP1230A has a PFC\_V<sub>CC</sub> output pin which provides the bias supply power for a Power Factor Correction controller, or other logic. The NCP1230A has an event management scheme which

disables the PFC\_V<sub>CC</sub> output during standby, and overload conditions.

### PFC\_V<sub>CC</sub>

As shown on the internal NCP1230A diagram, an internal low impedance switch SW1 routes Pin 6 (V<sub>CC</sub>) to Pin 1 when the power supply is operating under nominal load conditions. The PFC\_V<sub>CC</sub> signal is capable of delivering up to 35 mA of continuous current for a PFC Controller, or other logic.

Connecting the NCP1230A PFC\_V<sub>CC</sub> output to a PFC Controller chip is very straight forward, refer to the “Typical Application Example” all that is generally required is a small decoupling capacitor (0.1 μF).

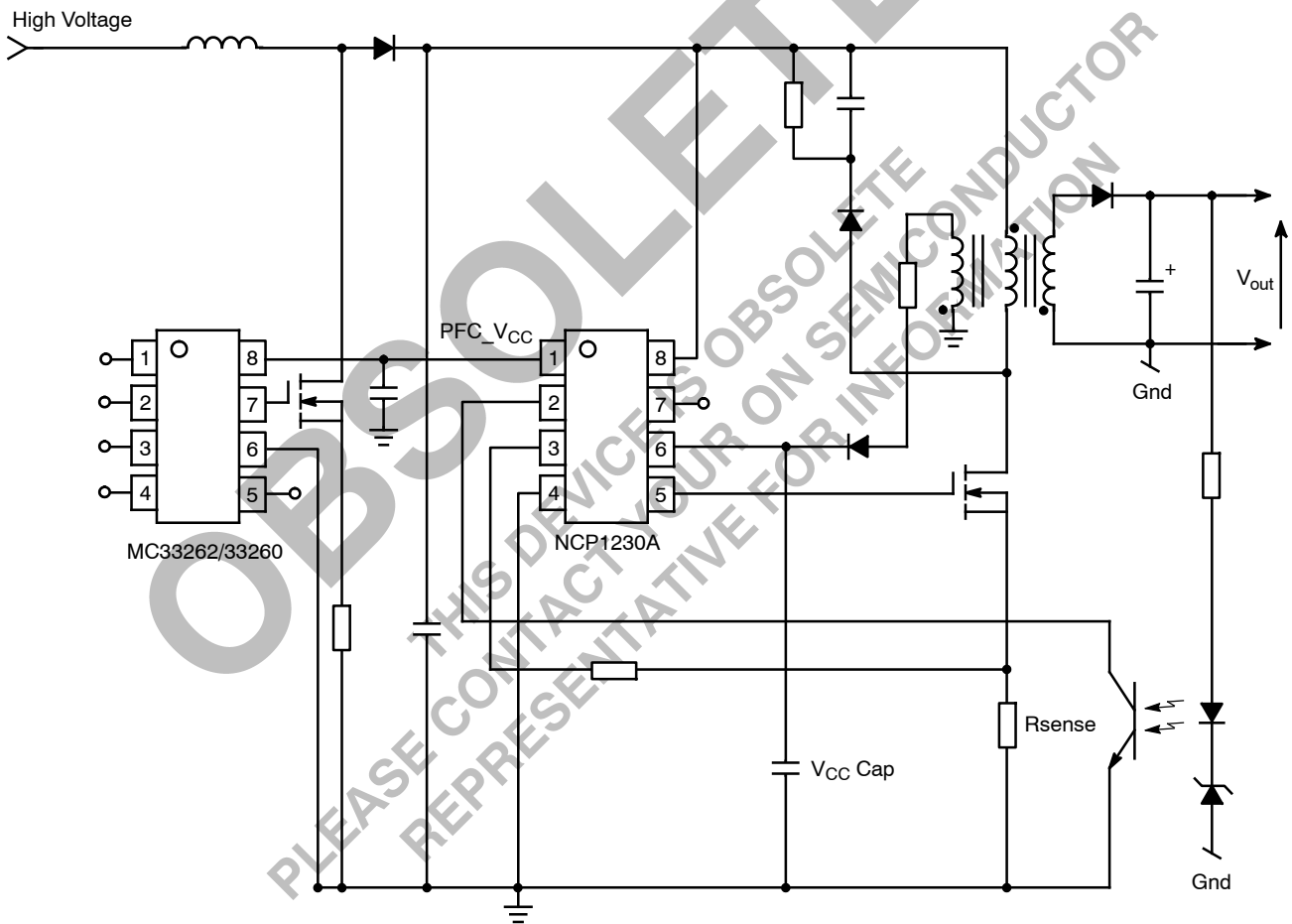
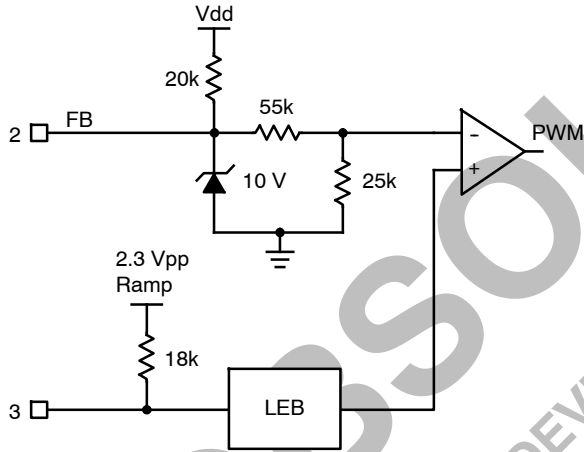

Figure 29. Typical Application Example

**Feedback**

The feedback pin has been designed to be connected directly to the open-collector output of an optocoupler. The pin is pulled-up through a 20 kΩ resistor to the internal V<sub>dd</sub> supply (6.5 volts nominal). The feedback input signal is divided down, by a factor of three, and connected to the negative (-) input of the PWM comparator. The positive (+) input to the PWM comparator is the current sense signal (Figure 30).

The NCP1230A is a peak current mode controller, where the feedback signal is proportional to the output power. At the beginning of the cycle, the power switch is turns-on and the current begins to increase in the primary of the transformer, when the peak current crosses the feedback voltage level, the PWM comparators switches from a logic level low, to a logic level high, resetting the PWM latching Flip-Flop, turning off the power switch until the next oscillator clock cycle begins.



**Figure 30.**

The feedback pin input is clamped to a nominal 10 volt for ESD protection.

**Soft Skip Mode**

The feedback input is connected in parallel with the skip cycle logic (Figure 32). When the feedback voltage drops below 25% of the maximum peak current (1.0 V/R<sub>sense</sub>) the IC prevents the current from decreasing any further and starts to blank the output pulses. This is called the soft skip mode. While the controller is in the soft skip mode the power transfer now depends upon the duty cycle of the pulse burst width which reduces the average input power demand.

When the controller determines that more energy is required to meet the output power demands, the NCP1230A goes through a soft-start cycle ramping up the current to the output. (Refer to Figure 31)

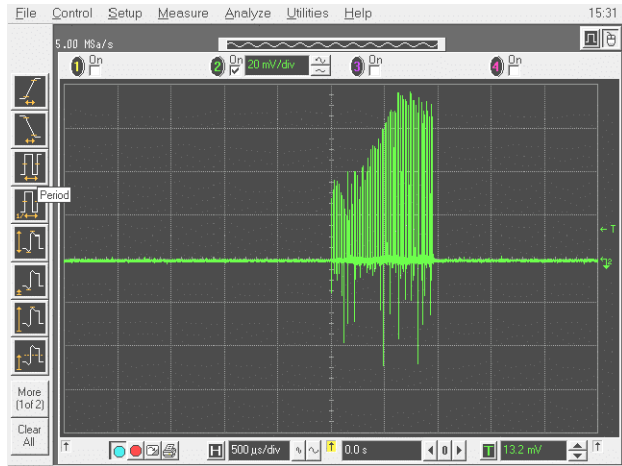

**Figure 31.**

When the feedback signal determines that the desired output power has been reached, the NCP1230A immediately turns off the skip mode (it does not ramp down the output current). This Soft Skip Mode is ideal for applications where a low standby power is required and a minimization of any audible noise that may be associated with magnetics and snubber components is needed.

$$V_c = I_{pk} \cdot R_s \cdot 3$$

where:

- V<sub>c</sub> = control voltage (Feedback pin input),
- I<sub>pk</sub> = Peak primary current,
- R<sub>s</sub> = Current sense resistor,
- 3 = Feedback divider ratio.

$$\text{SkipLevel} = 3V \cdot 25\% = 0.75V$$

$$I_{pk} = \frac{0.75}{R_s \cdot 3}$$

where:

$$I_{pk} \cdot R_s = 1V$$

$$I_{pk} = \sqrt{\frac{2 \cdot P_{in}}{L_p \cdot f}}$$

where:

P<sub>in</sub> = is the power level where the NCP1230A will go into the skip mode

L<sub>p</sub> = Primary inductance

f = NCP1230A controller frequency

$$P_{in} = \frac{L_p \cdot f \cdot I_{pk}^2}{2}$$

$$P_{in} = \frac{P_{out}}{Eff}$$

where:

Eff = the power supply efficiency

$$R_{out} = \frac{E_{out}^2}{P_{out}}$$

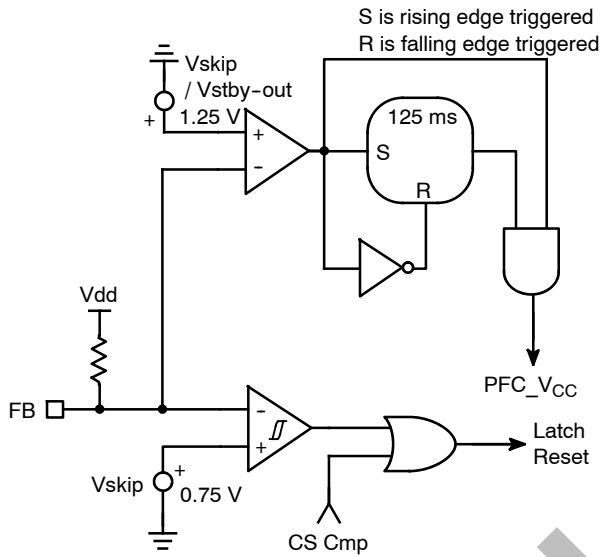

Figure 32.

During the soft skip mode the PFC\_Vcc signal (pin 1) is asserted into a high impedance state when a light load condition is detected and confirmed, Figure 33 shows typical waveforms. The first section of the waveform shows a normal startup condition, where the output voltage is low, as a result the feedback signal will be high asking the controller to provide the maximum power to the output. The second phase is under normal loading, and the output is in regulation. The third phase is when the output power drops below the 25% threshold (the feedback voltage drops to 0.75 volts). When this occurs, the 125 msec timer starts, and if the conditions is still present after the time output period, the NCP1230A confirms that the low output power condition is present, and the internal SW1 opens, and the PFC\_Vcc signal output is shuts down. While the NCP1230A is in the skip mode the FB pin will move around the 750 mV threshold level, with approximately 100 mVp-p of hysteresis on the skip comparator, at a period which depends upon the (light) loading of the power supply and its various time constants. Since this ripple amplitude superimposed over the FB pin is lower than the second threshold (1.25 volt), the PFC\_Vcc comparator output stays high (PFC\_Vcc output Pin 1 is low).

In Phase four, the output power demands have increases and the feedback voltage rises above the 1.25 volts threshold, the NCP1230A exits the skip mode, and returns to normal operation.

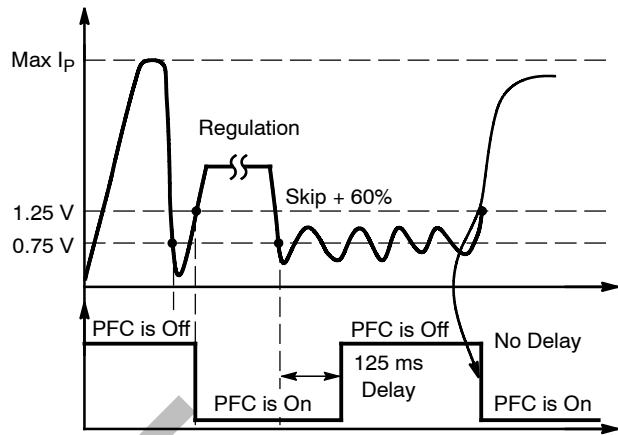

Figure 33.

### Leaving standby (Soft Skip Mode)

When the feedback voltage rises above the 1.25 volts reference (leaving standby) the skip cycle activity stops and SW1 immediately closes and restarts the PFC, there is no delay in turning on SW1 under these conditions, refer to Figure 33.

### Current Sense

The NCP1230A is a peak current mode controller, where the current sense input is internally clamped to 1.0 V, so the sense resistor is determined by  $R_{sense} = 1.0 \text{ V} / I_{pk}$  maximum.

There is a 18k resistor connected to the CS pin, the other end of the 18k resistor is connect to the output of the internal oscillator for ramp compensation (refer to Figure 34).

### Ramp Compensation

In Switch Mode Power Supplies operating in Continuous Conduction Mode (CCM) with a duty-cycle greater than 50%, oscillation will take place at half the switching frequency. To eliminate this condition, Ramp Compensation can be added to the current sense signal to cure sub harmonic oscillations. To lower the current loop gain one typically injects between 50 and 100% of the inductor down slope.

The NCP1230A provides an internal 2.3 Vpp ramp which is summed internally through a 18 kΩ resistor to the current sense pin. To implement ramp compensation a resistor needs to be connected from the current sense resistor, to the current sense pin 3.

Example:

If we assume we are using the 65 kHz version of the NCP1230A, at 65 kHz the dv/dt of the ramp is 130 mV/μs. Assuming we are designing a FLYBACK converter which has a primary inductance, Lp, of 350 μH, and the SMPS has

a +12 V output with a Np:Ns ratio of 1:0.1. The OFF time primary current slope is given by:

$$\frac{(V_{out} + V_f) \cdot \frac{N_s}{N_p}}{L_p} = 371 \text{ mA}/\mu\text{s} \text{ or } 37 \text{ mV}/\mu\text{s}$$

when imposed on a current sense resistor (Rsense) of 0.1 Ω. If we select 75% of the inductor current downslope as our required amount of ramp compensation, then we shall inject 27 mV/μs.

With our internal compensation being of 130 mV, the divider ratio (*divratio*) between Rcomp and the 18 kΩ is 0.207. Therefore:

$$R_{comp} = \frac{18k \cdot \text{divratio}}{(1 - \text{divratio})} = 4.69 \text{ k}\Omega$$

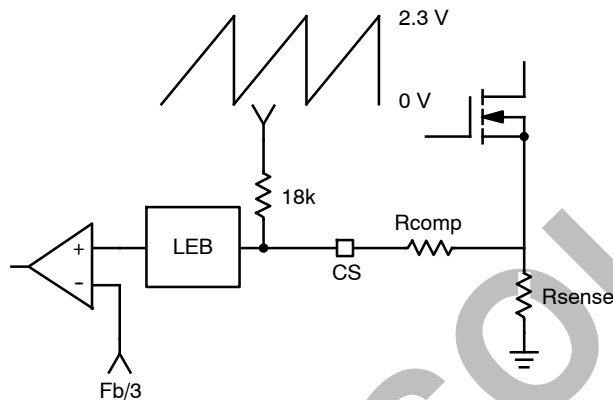

Figure 34.

**Leading Edge Blanking**

In Switch Mode Power Supplies (SMPS) there can be a large current spike at the beginning of the current ramp due to the Power Switch gate to source capacitance, transformer interwinding capacitance, and output rectifier recovery time. To prevent prematurely turning off the PWM drive output, a Leading Edges Blanking (LEB) (Figure 35) circuit is placed in series with the current sense input, and PWM comparator. The LEB circuit masks the first 250 ns of the current sense signal.

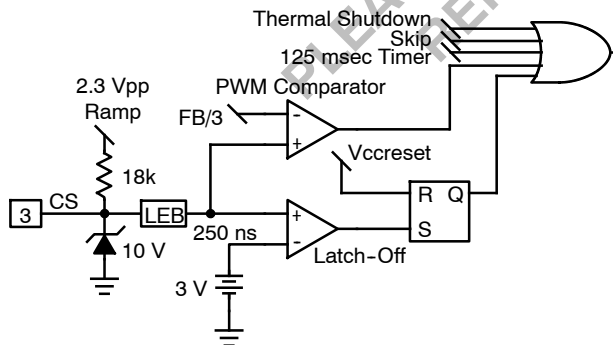

Figure 35.

**Short-Circuit Condition**

The NCP1230A is different from other controllers which use an auxiliary windings to detect events on the isolated secondary output. There maybe some conditions (for example when the leakage inductance is high) where it can be extremely difficult to implement short-circuit and overload protection. This occurs because when the power switch opens, the leakage inductance superimposes a large spike on the switch drain voltage. This spike is seen on the isolated secondary output and on the auxiliary winding. Because the auxiliary winding and diode form a peak rectifier, the auxiliary Vcc capacitor voltage can be charged up to the peak value rather than the true plateau which is proportional to the output level.

To resolve these issues the NCP1230A monitors the 1.0 V error flag. As soon as the internal 1.0 V error flag is asserted high, a 125 ms timer starts. If at the end of the 125 ms timeout period, the error flag is still asserted then the controller determines that there is a true fault condition and stops the PWM drive output, refer to Figure 36. When this occurs, Vcc starts to decrease because the power supply is locked out. When Vcc drops below UVLOlow (7.7 V typical), it enters a latch-off phase where the internal consumption is reduced down to 680 μA (typical). The voltage on the Vcc capacitor continues to drop, but at a lower rate. When Vcc reaches the latch-off level (5.6 V), the current source is turned on and pulls Vcc above UVLOhigh. To limit the fault output power, a divide-by-two circuit is connected to the Vcc pin that requires two startup sequences before attempting to restart the power supply. If the fault has gone and the error flag is low, the controller resumes normal operations.

Under transient load conditions, if the error flag is asserted, the error flag will normally drop prior to the 125 ms time out period and the controller continues to operate normally.

If the 125 msec timer expires while the NCP1230A is in the Skip Mode, SW1 opens and the PFC\_Vcc output will shut down and will not be activated until the fault goes away and the power supply resumes normal operations.

While in the Skip Mode, to avoid any thermal runaway it is desirable for the soft skip duty cycle to be kept below 20%(the soft skip duty-cycle is defined as Tpulse / Tfault).

# NCP1230A

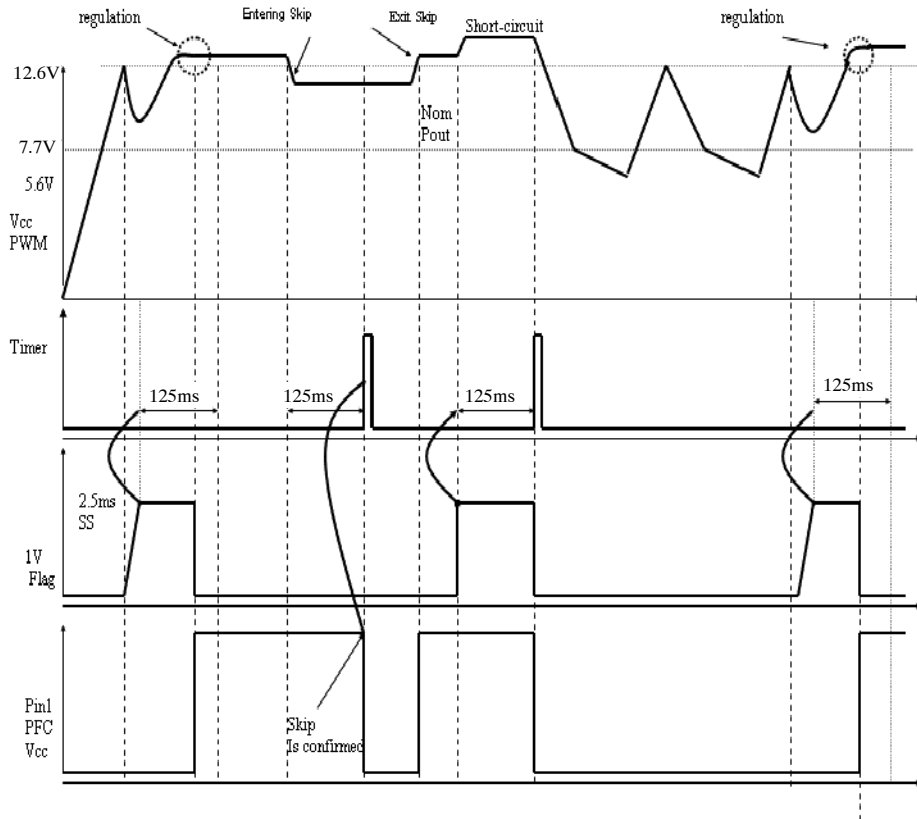

**Figure 36.**

The latch-off phase can also be initiated, more classically, when V<sub>cc</sub> drops below UVLO (7.7 V typical). During this fault detection method, the controller will not wait for the

125 ms time-out, or the error flag before it goes into the latch-off phase, operating in the skip mode under these conditions, refer to Figure 37.

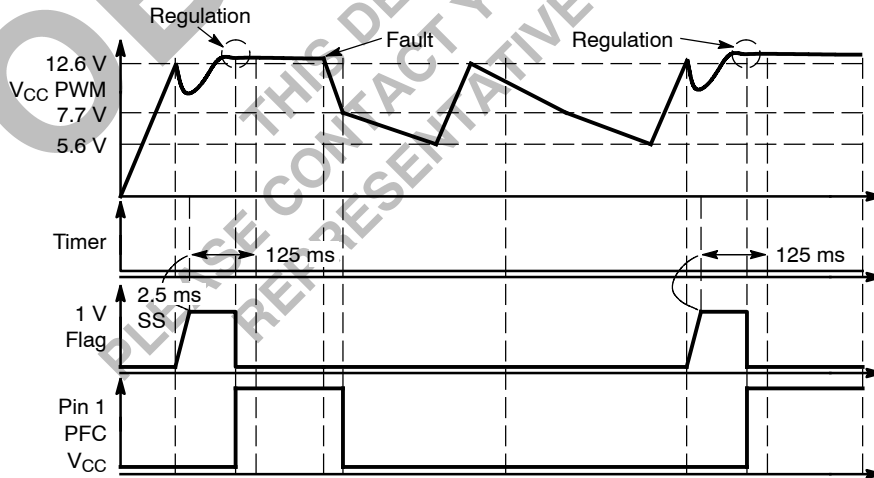

**Figure 37.**



**Current Sense Input Pin Latch-Off**

The NCP1230A features a fast comparator (Figure 35) that monitors the current sense pin during the controller off time. If for any reason the voltage on pin 3 increases above 3.0 V, the NCP1230A immediately stops the PWM drive pulses and permanently stays latched off until the bias supply to the NCP1230A is cycled down ( $V_{cc}$  must drop below 4.0 V, e.g. when the user unplugs the converter from the mains). This offers the designer the flexibility to implement an externally shutdown circuit (for example for over voltage or over temperature conditions). When the controller is latched off through pin 3 (current sense), SW1 opens and shuts off PFC\_  $V_{cc}$  output.

Figure 38 shows how to implement the external latch via a Zener diode and a simple PNP transistor. The PNP actually samples the Zener voltage during the OFF time only, hence leaving the CS information un-altered during the ON time. Various component arrangements can be made, e.g. adding a NTC device for the Over Temperature Protection (OTP).

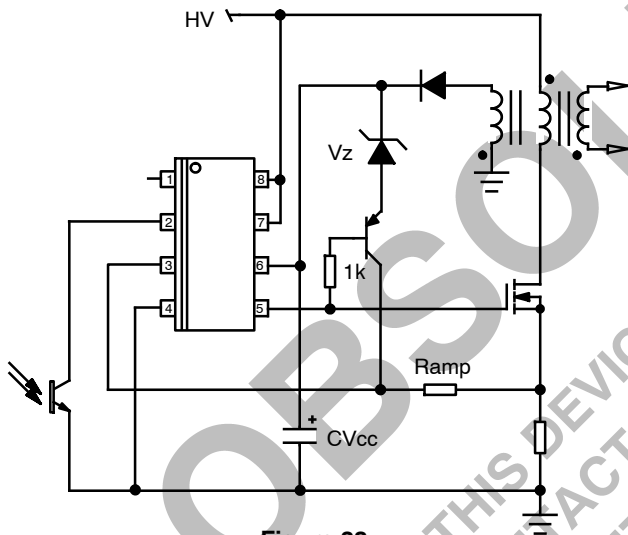

**Figure 38.**

Connecting the PNP to the drive only activates the offset generation during Toff. Here is a solution monitoring the auxiliary  $V_{cc}$  rail.

**Drive Output**

The NCP1230A provides a Drive Output which can be connected through a current limiting resistor to the gate of a MOSFET. The Driver output is capable of delivering drive pulses with a rise time of 40 ns, and a fall time of 15 ns through its internal source and sink resistance of 12.3 ohms (typical), measured with a 1.0 nf capacitive load.

**Startup Sequence**

The NCP1230A has an internal High Voltage Startup Circuit (Pin 8) which is connected to the high voltage DC bus (Refer to Figure 37). When power is applied to the bus, the NCP1230A internal current source (typically 3.2 mA) is biased and charges up the external  $V_{cc}$  capacitor on pin 6, refer to Figure 39. When the voltage on pin 6 ( $V_{cc}$ ) reaches

$V_{ccoff}$  (12.6 V typically), the current source is turned off reducing the amount of power being dissipated in the chip. The NCP1230A then turns on the drive output to the external MOSFET in an attempt to increase the output voltage and charge up the  $V_{cc}$  capacitor through the  $V_{aux}$  winding in the transformer.

During the startup sequence, the controller pushes for the maximum peak current, which is reached after the 2.5 ms soft-start period. As soon as the maximum peak set point is reached, the internal 1.0 V Zener diode actively limits the current amplitude to 1.0 V/ $R_{sense}$  and asserts an error flag indicating that a maximum current condition is being observed. In this mode, the controller must determine if it is a normal startup period (or transient load) or is the controller is facing a fault condition. To determine the difference between a normal startup sequence, and a fault condition, the error flag is asserted, and the 125 ms timer starts to count down. If the error flag drops prior to the 125 msec time-out period, the controller resets the timer and determines that it was a normal startup sequence and enables the low impedance switch (SW1), enabling the PFC\_  $V_{cc}$  output.

If at the end of the 125 ms period the error flag is still asserted, then the controller assumes that it is a fault condition and the PWM controller enters the skip mode and does not enable the PFC\_  $V_{cc}$  output.

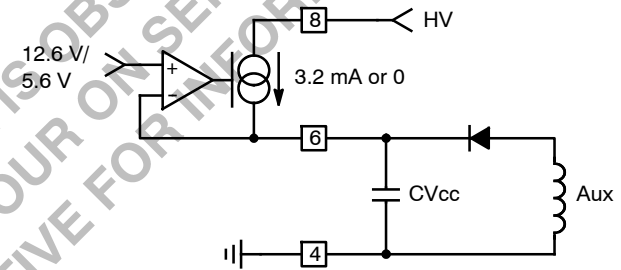

**Figure 39.**

ON Semiconductor recommends that the  $V_{cc}$  capacitor be at least 47  $\mu$ F to be sure that the  $V_{cc}$  supply voltage does not drop below  $V_{ccmin}$  (7.7 V typical) during standby power mode and unusual fault conditions.

**Soft-Start**

The NCP1230A features an internal 2.5 ms soft-start circuit. As soon as  $V_{cc}$  reaches a nominal 12.6 V, the soft-start circuit is activated. The soft-start circuit output controls a reference on the minus (-) input to an amplifier (refer to Figure 40), the positive (+) input to the amplifier is the feedback input (divided by 3). The output of the amplifier drives a FET which clamps the feedback signal. As the soft-start circuit output ramps up, it allow the feedback pin input to the PWM comparator to gradually increased from near zero up to the maximum clamping level of 1.0 V/ $R_{sense}$ . This occurs over the entire 2.5 ms soft-start period until the supply enters regulation. The soft-start is also activated every time a restart is attempted. Figure 41 shows a typical soft-start up sequence.

# NCP1230A

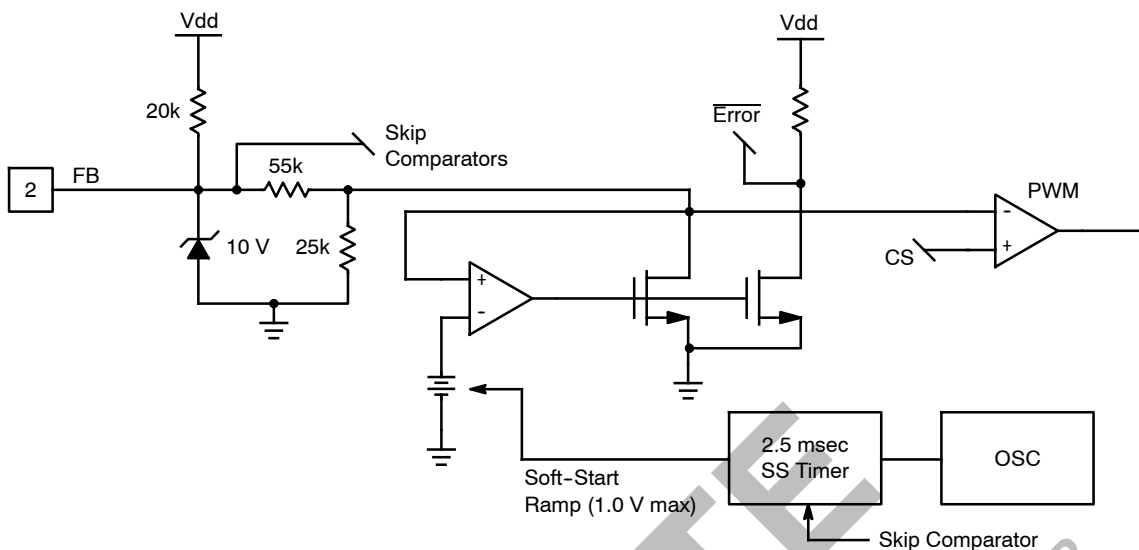

Figure 40.

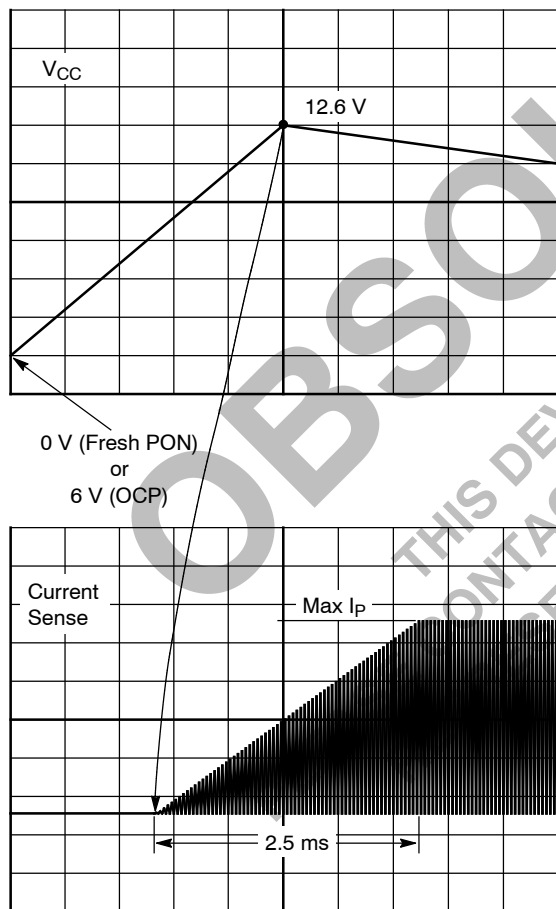

Figure 41. Soft-Start is Activated during a Startup Sequence, an OCP Condition, or in Skip Mode

## NCP1230A

### Frequency Jittering

Frequency jittering is a method used to soften the EMI signature by spreading out the average switching energy around the controller operating switching frequency. The NCP1230A offers a nominal  $\pm 6.4\%$  deviation of the

nominal switching frequency. The sweep sawtooth is internally generated and modulates the clock up and down with a 5 ms period. Figure 42 illustrates the NCP1230A behavior:

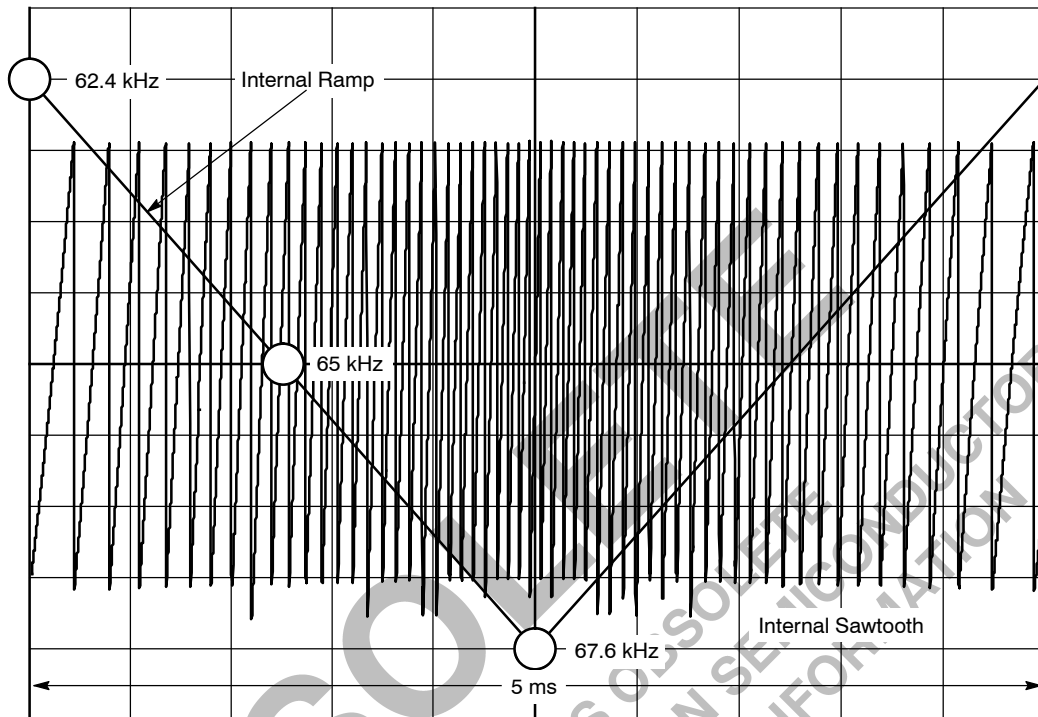

Figure 42. An Internal Ramp is used to Introduce Frequency Jittering on the Oscillator Saw Tooth

### Thermal Protection

An internal Thermal Shutdown is provided to protect the integrated circuit in the event that the maximum junction temperature is exceeded. When activated (165 °C typically) the controller turns off the PWM Drive Output. When this occurs,  $V_{cc}$  will drop (the rate is dependent on the NCP1230A loading and the size of the  $V_{cc}$  capacitor) because the controller is no longer delivering drive pulses to the auxiliary winding charging up the  $V_{cc}$  capacitor. When

$V_{cc}$  drops below 4.0 volts and the  $V_{cc}$ reset circuit is activated, the controller will restart. If the user is using a fixed bias supply (the bias supply is provided from a source other than from an auxiliary winding, refer to the typical application ) and  $V_{cc}$  is not allow to drop below 4.0 volts under a thermal shutdown condition, the NCP1230A will not restart. This feature is provided to prevent catastrophic failure from accidentally overheating the device.

# NCP1230A

## PACKAGE DIMENSIONS

SOIC-8 NB  
CASE 751-07  
ISSUE AJ

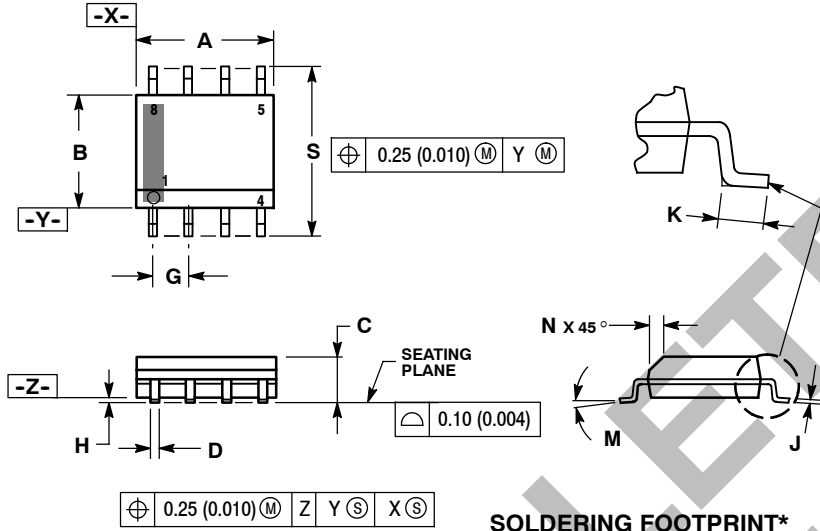

### NOTES:

1. DIMENSIONING AND TOLERANCING PER ANSI Y14.5M, 1982.
2. CONTROLLING DIMENSION: MILLIMETER.
3. DIMENSION A AND B DO NOT INCLUDE MOLD PROTRUSION.
4. MAXIMUM MOLD PROTRUSION 0.15 (0.006) PER SIDE.
5. DIMENSION D DOES NOT INCLUDE DAMBAR PROTRUSION. ALLOWABLE DAMBAR PROTRUSION SHALL BE 0.127 (0.005) TOTAL IN EXCESS OF THE D DIMENSION AT MAXIMUM MATERIAL CONDITION.
6. 751-01 THRU 751-06 ARE OBSOLETE. NEW STANDARD IS 751-07.

DIM	MILLIMETERS		INCHES	
	MIN	MAX	MIN	MAX
A	4.80	5.00	0.189	0.197
B	3.80	4.00	0.150	0.157
C	1.35	1.75	0.053	0.069
D	0.33	0.51	0.013	0.020
G	1.27 BSC		0.050 BSC	
H	0.10	0.25	0.004	0.010
J	0.19	0.25	0.007	0.010
K	0.40	1.27	0.016	0.050
M	0°	8°	0°	8°
N	0.25	0.50	0.010	0.020
S	5.80	6.20	0.228	0.244

### SOLDERING FOOTPRINT\*

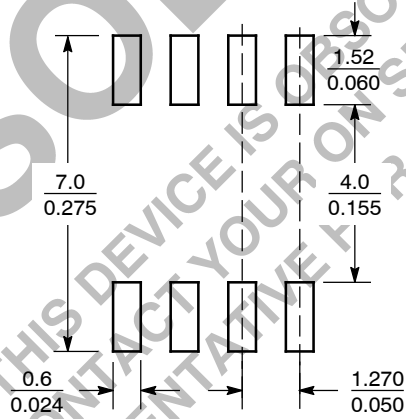

SCALE 6:1  $\left(\frac{\text{mm}}{\text{inches}}\right)$

\*For additional information on our Pb-Free strategy and soldering details, please download the ON Semiconductor Soldering and Mounting Techniques Reference Manual, SOLDERRM/D.

# NCP1230A

## PACKAGE DIMENSIONS

7-LEAD PDIP  
P SUFFIX  
CASE 626B-01  
ISSUE A

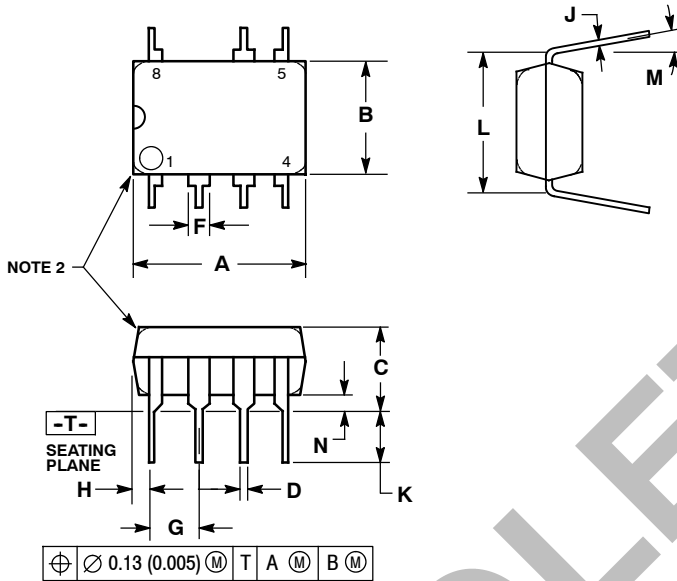

### NOTES:

1. DIMENSIONS AND TOLERANCING PER ASME Y14.5M, 1994.
2. DIMENSIONS IN MILLIMETERS.
3. DIMENSION L TO CENTER OF LEAD WHEN FORMED PARALLEL.
4. PACKAGE CONTOUR OPTIONAL (ROUND OR SQUARE CORNERS).
5. DIMENSIONS A AND B ARE DATUMS.

MILLIMETERS	
DIM	MIN MAX
A	9.40 10.16
B	6.10 6.60
C	3.94 4.45
D	0.38 0.51
F	1.02 1.78
G	2.54 BSC
H	0.76 1.27
J	0.20 0.30
K	2.92 3.43
L	7.62 BSC
M	10 °
N	0.76 1.01

**ON Semiconductor** and **ON** are registered trademarks of Semiconductor Components Industries, LLC (SCILLC). SCILLC reserves the right to make changes without further notice to any products herein. SCILLC makes no warranty, representation or guarantee regarding the suitability of its products for any particular purpose, nor does SCILLC assume any liability arising out of the application or use of any product or circuit, and specifically disclaims any and all liability, including without limitation special, consequential or incidental damages. "Typical" parameters which may be provided in SCILLC data sheets and/or specifications can and do vary in different applications and actual performance may vary over time. All operating parameters, including "Typicals" must be validated for each customer application by customer's technical experts. SCILLC does not convey any license under its patent rights nor the rights of others. SCILLC products are not designed, intended, or authorized for use as components in systems intended for surgical implant into the body, or other applications intended to support or sustain life, or for any other application in which the failure of the SCILLC product could create a situation where personal injury or death may occur. Should Buyer purchase or use SCILLC products for any such unintended or unauthorized application, Buyer shall indemnify and hold SCILLC and its officers, employees, subsidiaries, affiliates, and distributors harmless against all claims, costs, damages, and expenses, and reasonable attorney fees arising out of, directly or indirectly, any claim of personal injury or death associated with such unintended or unauthorized use, even if such claim alleges that SCILLC was negligent regarding the design or manufacture of the part. SCILLC is an Equal Opportunity/Affirmative Action Employer. This literature is subject to all applicable copyright laws and is not for resale in any manner.

### PUBLICATION ORDERING INFORMATION

**LITERATURE FULFILLMENT:**  
Literature Distribution Center for ON Semiconductor  
P.O. Box 5163, Denver, Colorado 80217 USA  
**Phone:** 303-675-2175 or 800-344-3860 Toll Free USA/Canada  
**Fax:** 303-675-2176 or 800-344-3867 Toll Free USA/Canada  
**Email:** orderlit@onsemi.com

**N. American Technical Support:** 800-282-9855 Toll Free  
USA/Canada  
**Europe, Middle East and Africa Technical Support:**  
Phone: 421 33 790 2910  
**Japan Customer Focus Center**  
Phone: 81-3-5773-3850

**ON Semiconductor Website:** [www.onsemi.com](http://www.onsemi.com)  
**Order Literature:** <http://www.onsemi.com/orderlit>

For additional information, please contact your local Sales Representative