

4-Kbit serial I²C bus EEPROM with write control of the top half of memory

Datasheet – production data

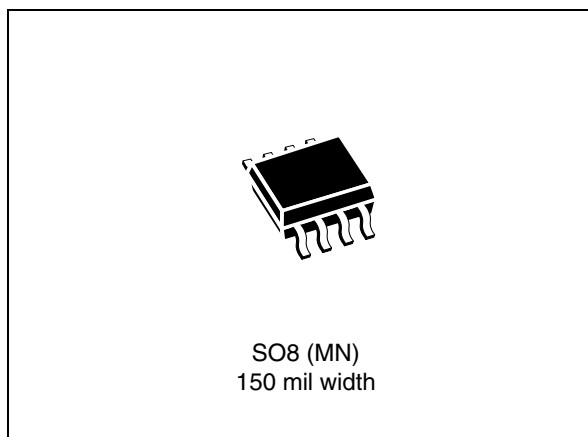

Features

- Two-wire I²C serial interface supports
- 400 kHz protocol
- Single supply voltage
 - 2.5 to 5.5 V
- Write control of the top half of memory (addresses 100h to 1FFh)
- Byte and Page Write (up to 16 Bytes)
- Random and Sequential Read modes
- Self-timed programming cycle
- Automatic address incrementing
- Enhanced ESD/latch-up behavior
- More than 1 million erase/write cycles
- More than 40 year data retention
- Package
 - SO8 ECOPACK[®]2

Contents

- 1 Description 6**
- 2 Signal description 8**
 - 2.1 Serial clock (SCL) 8
 - 2.2 Serial data (SDA) 8
 - 2.3 Chip enable (E1, E2) 8
 - 2.4 Write control (WC) 8
 - 2.5 Supply voltage (V_{CC}) 9
 - 2.5.1 Operating supply voltage V_{CC} 9
 - 2.5.2 Internal device reset 9
 - 2.5.3 Power-down 9
- 3 Device operation 10**
 - 3.1 Start condition 10
 - 3.2 Stop condition 10
 - 3.3 Acknowledge bit (ACK) 10
 - 3.4 Data input 10
 - 3.5 Memory addressing 11
 - 3.6 Write operations 12
 - 3.7 Byte write 12
 - 3.8 Page write 13
 - 3.9 Minimizing system delays by polling on ACK 14
 - 3.10 Read operations 15
 - 3.11 Random address read 15
 - 3.12 Current address read 16
 - 3.13 Sequential read 16
 - 3.14 Acknowledge in read mode 16
- 4 Initial delivery state 17**
- 5 Maximum ratings 18**
- 6 DC and AC parameters 19**

7	Package mechanical data	22
	7.1 SO8N package information	22
8	Part numbering	24
9	Revision history	25

List of tables

Table 1.	Signal names	6
Table 2.	Device select code	11
Table 3.	Operating modes	11
Table 4.	Absolute maximum ratings	18
Table 5.	Operating conditions	19
Table 6.	AC measurement conditions	19
Table 7.	Input parameters	19
Table 8.	DC characteristics	20
Table 9.	AC characteristics	20
Table 10.	SO8N – 8-lead plastic small outline, 150 mils body width, package mechanical data	22
Table 11.	Ordering information scheme	24
Table 12.	Document revision history	25

List of figures

Figure 1.	Logic diagram	6
Figure 2.	SO connections	7
Figure 3.	I2C bus protocol	9
Figure 4.	Write mode sequences, to addresses in the top half, with WC=1 (data write inhibited) . . .	12
Figure 5.	Write mode sequences with WC=0 (data write enabled)	13
Figure 6.	Write cycle polling flowchart using ACK	14
Figure 7.	Read mode sequences	15
Figure 8.	AC measurement I/O waveform	19
Figure 9.	AC waveforms	21
Figure 10.	Maximum RL value versus bus capacitance (CBUS) for an I2C bus	21
Figure 11.	SO8N – 8-lead plastic small outline, 150 mils body width, package outline	22
Figure 12.	SO8N – 8-lead plastic small outline, 150 mils body width, package recommended footprint	23

1 Description

The M34F04 is an electrically erasable programmable memory (EEPROM), organized as 512 x 8. The upper half (1FFh to 100h) of the memory array can be protected from inadvertent write operations by driving High the \overline{WC} pin.

Figure 1. Logic diagram

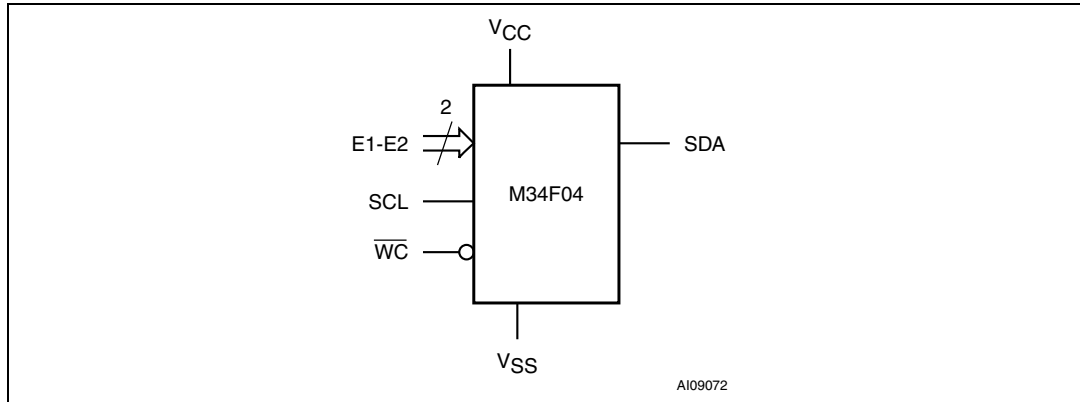

These devices are compatible with the I²C memory protocol. This is a two wire serial interface that uses a bi-directional data bus and serial clock. The devices carry a built-in 4-bit Device Type Identifier code (1010) in accordance with the I²C bus definition.

The device behaves as a slave in the I²C protocol, with all memory operations synchronized by the serial clock. Read and Write operations are initiated by a Start condition, generated by the bus master. The Start condition is followed by a Device Select Code and RW bit (as described in [Table 2](#)), terminated by an acknowledge bit.

When writing data to the memory, the device inserts an acknowledge bit during the 9th bit time, following the bus master's 8-bit transmission. When data is read by the bus master, the bus master acknowledges the receipt of the data byte in the same way. Data transfers are terminated by a Stop condition after an Ack for Write, and after a NoAck for Read.

Table 1. Signal names

Name	Definition
E1, E2	Chip Enable
SDA	Serial Data
SCL	Serial Clock
WC	Write Control
V _{CC}	Supply Voltage
V _{SS}	Ground

Figure 2. SO connections

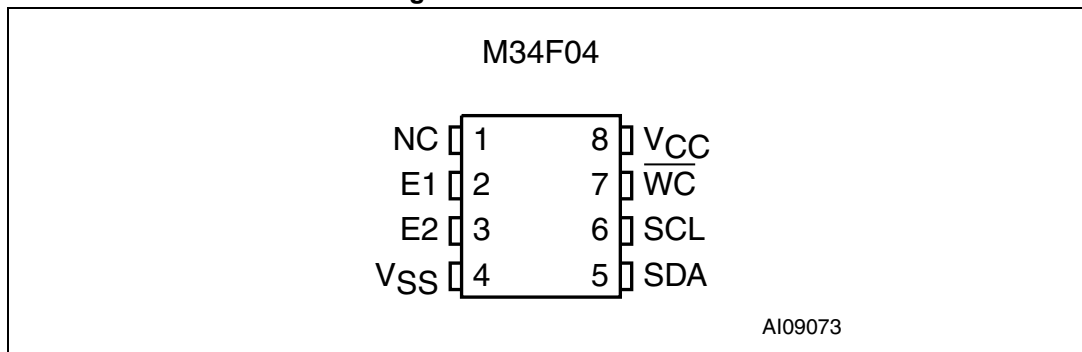

NC = Not Connected

See [Section 7: Package mechanical data](#) for package dimensions, and how to identify pin-1.

2 Signal description

2.1 Serial clock (SCL)

This input signal is used to strobe all data in and out of the device. In applications where this signal is used by slave devices to synchronize the bus to a slower clock, the bus master must have an open drain output, and a pull-up resistor can be connected from Serial Clock (SCL) to V_{CC} . (Figure 10 indicates how the value of the pull-up resistor can be calculated). In most applications, though, this method of synchronization is not employed, and so the pull-up resistor is not necessary, provided that the bus master has a push-pull (rather than open drain) output.

2.2 Serial data (SDA)

This bi-directional signal is used to transfer data in or out of the device. It is an open drain output that may be wire-OR'ed with other open drain or open collector signals on the bus. A pull up resistor must be connected from Serial Data (SDA) to V_{CC} . (Figure 10 indicates how the value of the pull-up resistor can be calculated).

2.3 Chip enable (E1, E2)

These input signals are used to set the value that is to be looked for on the three least significant bits (b3, b2) of the 7-bit Device Select Code. These inputs must be tied to V_{CC} or V_{SS} , to establish the Device Select Code.

2.4 Write control (\overline{WC})

This input signal is useful for protecting half of the memory from inadvertent write operations. Write operations are disabled to the upper half (1FFh to 100h) of the memory array when Write Control (\overline{WC}) is driven High. When unconnected, the signal is internally read as V_{IL} , and Write operations are allowed.

When attempting to write in the upper half of the memory, while Write Control (\overline{WC}) is being driven High, Device Select and Address bytes are acknowledged, Data bytes are not acknowledged.

2.5 Supply voltage (V_{CC})

2.5.1 Operating supply voltage V_{CC}

Prior to selecting the memory and issuing instructions to it, a valid and stable V_{CC} voltage must be applied: this voltage must be a DC voltage within the specified [$V_{CC}(\min)$, $V_{CC}(\max)$] range as defined in [Table 5](#). This voltage must remain stable and valid until the end of the transmission of the instruction and, for a Write instruction, until the completion of the internal write cycle (t_W).

2.5.2 Internal device reset

In order to prevent inadvertent Write operations during Power-up, a Power On Reset (POR) circuit is included. At Power-up (continuous rise of V_{CC}), the device will not respond to any instruction until V_{CC} has reached the Power On Reset threshold voltage (this threshold is lower than the minimum V_{CC} operating voltage defined in [Section 6: DC and AC parameters](#)).

When V_{CC} has passed the POR threshold voltage, the device is reset and in the Standby Power mode.

2.5.3 Power-down

At power-down (where V_{CC} decreases continuously), as soon as V_{CC} drops from the normal operating voltage to below the Power On Reset threshold voltage, the device stops responding to any instruction sent to it.

Figure 3. I²C bus protocol

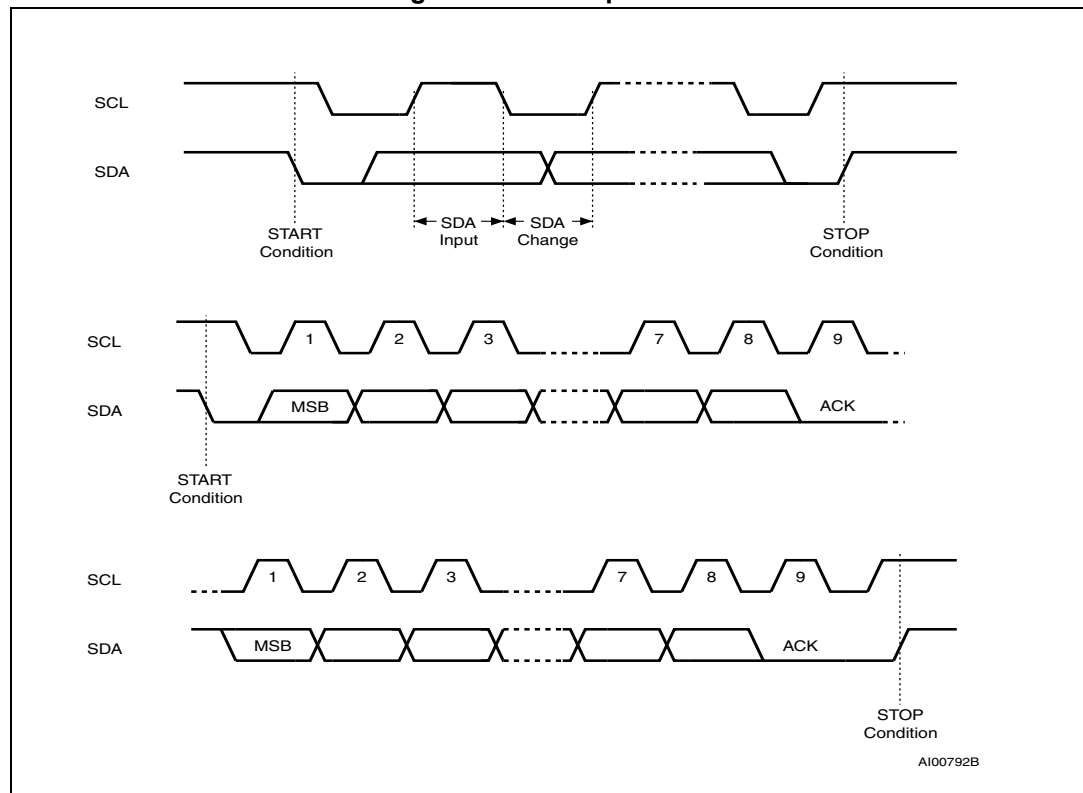

3 Device operation

The device supports the I²C protocol. This is summarized in [Figure 3](#). Any device that sends data on to the bus is defined to be a transmitter, and any device that reads the data to be a receiver. The device that controls the data transfer is known as the bus master, and the other as the slave device. A data transfer can only be initiated by the bus master, which will also provide the serial clock for synchronization. The M24Cxx device is always a slave in all communication.

3.1 Start condition

Start is identified by a falling edge of Serial Data (SDA) while Serial Clock (SCL) is stable in the High state. A Start condition must precede any data transfer command. The device continuously monitors (except during a Write cycle) Serial Data (SDA) and Serial Clock (SCL) for a Start condition, and will not respond unless one is given.

3.2 Stop condition

Stop is identified by a rising edge of Serial Data (SDA) while Serial Clock (SCL) is stable and driven High. A Stop condition terminates communication between the device and the bus master. A Read command that is followed by NoAck can be followed by a Stop condition to force the device into the Stand-by mode. A Stop condition at the end of a Write command triggers the internal EEPROM Write cycle.

3.3 Acknowledge bit (ACK)

The acknowledge bit is used to indicate a successful byte transfer. The bus transmitter, whether it be bus master or slave device, releases Serial Data (SDA) after sending eight bits of data. During the 9th clock pulse period, the receiver pulls Serial Data (SDA) Low to acknowledge the receipt of the eight data bits.

3.4 Data input

During data input, the device samples Serial Data (SDA) on the rising edge of Serial Clock (SCL). For correct device operation, Serial Data (SDA) must be stable during the rising edge of Serial Clock (SCL), and the Serial Data (SDA) signal must change *only* when Serial Clock (SCL) is driven Low.

3.5 Memory addressing

To start communication between the bus master and the slave device, the bus master must initiate a Start condition. Following this, the bus master sends the Device Select Code, shown in [Table 2](#) (on Serial Data (SDA), most significant bit first).

The Device Select Code consists of a 4-bit Device Type Identifier, and a 2-bit Chip Enable "Address" (E2, E1). To address the memory array, the 4-bit Device Type Identifier is 1010b.

Table 2. Device select code

	Device Type Identifier ⁽¹⁾				Chip Enable ⁽²⁾⁽³⁾			\overline{RW}
	b7	b6	b5	b4	b3	b2	b1	b0
Device Select Code	1	0	1	0	E2	E1	A8	\overline{RW}

1. The most significant bit, b7, is sent first.
2. E1 and E2 are compared against the respective external pins on the memory device.
3. A8 represents most significant bits of the address.

When the Device Select Code is received on Serial Data (SDA), the device only responds if the Chip Enable Address is the same as the value on the Chip Enable (E1, E2) inputs.

The 8th bit is the Read/Write bit (\overline{RW}). This bit is set to 1 for Read and 0 for Write operations.

If a match occurs on the Device Select code, the corresponding device gives an acknowledgment on Serial Data (SDA) during the 9th bit time. If the device does not match the Device Select code, it deselects itself from the bus, and goes into Stand-by mode.

Using the E1 and E2 inputs pins, up to four M34F04 devices can be connected to one I²C bus.

Table 3. Operating modes

Mode	\overline{RW} bit	\overline{WC} ⁽¹⁾	Bytes	Initial Sequence
Current Address Read	1	X	1	START, Device Select, $\overline{RW} = 1$
Random Address Read	0	X	1	START, Device Select, $\overline{RW} = 0$, Address
	1	X		reSTART, Device Select, $\overline{RW} = 1$
Sequential Read	1	X	≥ 1	Similar to Current or Random Address Read
Byte Write (upper addresses)	0	V _{IL} or Z	1	START, Device Select, $\overline{RW} = 0$
Byte Write (lower addresses)	0	X	1	START, Device Select, $\overline{RW} = 0$
Page Write (upper addresses)	0	V _{IL} or Z	≤16	START, Device Select, $\overline{RW} = 0$
Page Write (lower addresses)	0	X	≤16	START, Device Select, $\overline{RW} = 0$

1. Z = unconnected and floating
X = VIH or VIL or unconnected and floating.

Figure 4. Write mode sequences, to addresses in the top half, with $\overline{WC}=1$ (data write inhibited)

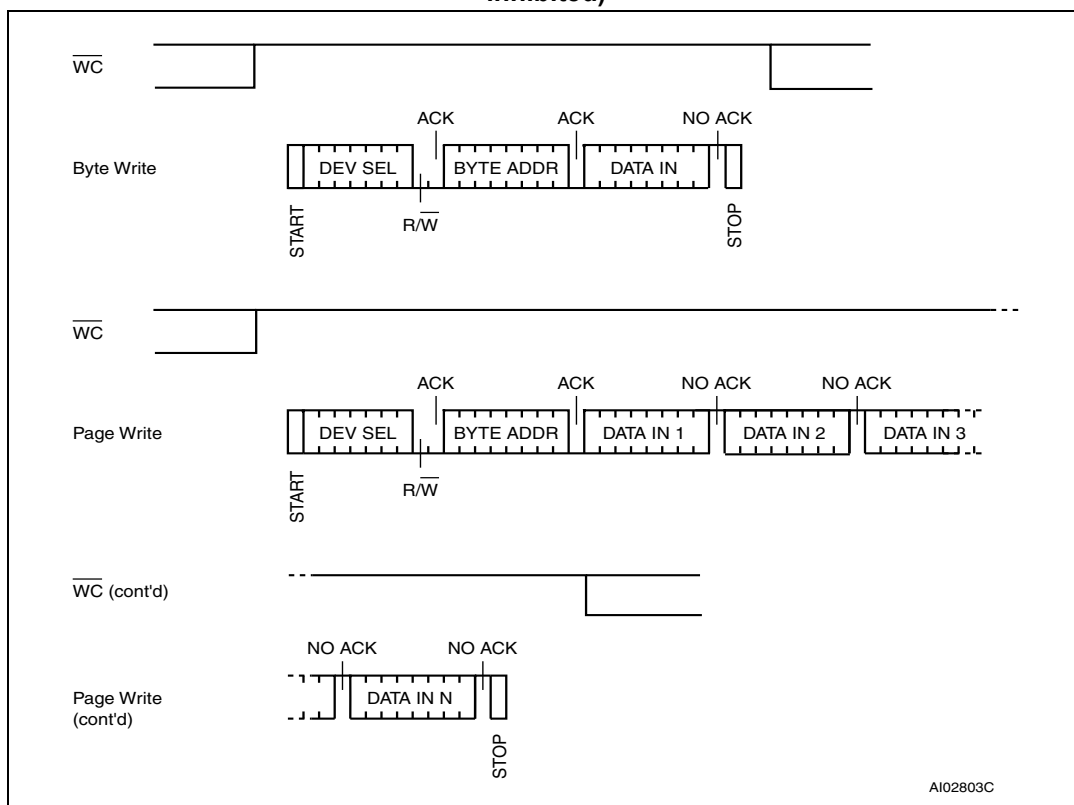

3.6 Write operations

Following a Start condition the bus master sends a Device Select Code with the $\overline{R/W}$ bit reset to 0. The device acknowledges this, as shown in Figure 5, and waits for an address byte. The device responds to the address byte with an acknowledge bit, and then waits for the data byte.

When the bus master generates a Stop condition immediately after the Ack bit (in the “10th bit” time slot), either at the end of a Byte Write or a Page Write, the internal memory Write cycle is triggered. A Stop condition at any other time slot does not trigger the internal Write cycle.

During the internal Write cycle, Serial Data (SDA) and Serial Clock (SCL) are ignored, and the device does not respond to any requests.

3.7 Byte write

After the Device Select code and the address byte, the bus master sends one data byte. If the addressed location is Write-protected, by Write Control (\overline{WC}) being driven High (during the period from the Start condition until the end of the address byte), the device replies to the data byte with NoAck, as shown in Figure 4, and the location is not modified. If, instead, the addressed location is not Write-protected, the device replies with Ack. The bus master terminates the transfer by generating a Stop condition, as shown in Figure 5.

3.8 Page write

The Page Write mode allows up to 16 bytes to be written in a single Write cycle, provided that they are all located in the same page in the memory: that is, the most significant memory address bits are the same. If more bytes are sent than will fit up to the end of the page, a condition known as 'roll-over' occurs. This should be avoided, as data starts to become overwritten in an implementation dependent way.

The bus master sends from 1 to 16 bytes of data, each of which is acknowledged by the device if Write Control (\overline{WC}) is Low. If the addressed location is Write-protected, by Write Control (\overline{WC}) being driven High (during the period from the Start condition until the end of the address byte), the device replies to the data bytes with NoAck, as shown in [Figure 4](#), and the locations are not modified. After each byte is transferred, the internal byte address counter (the 4 least significant address bits only) is incremented. The transfer is terminated by the bus master generating a Stop condition.

Figure 5. Write mode sequences with $\overline{WC}=0$ (data write enabled)

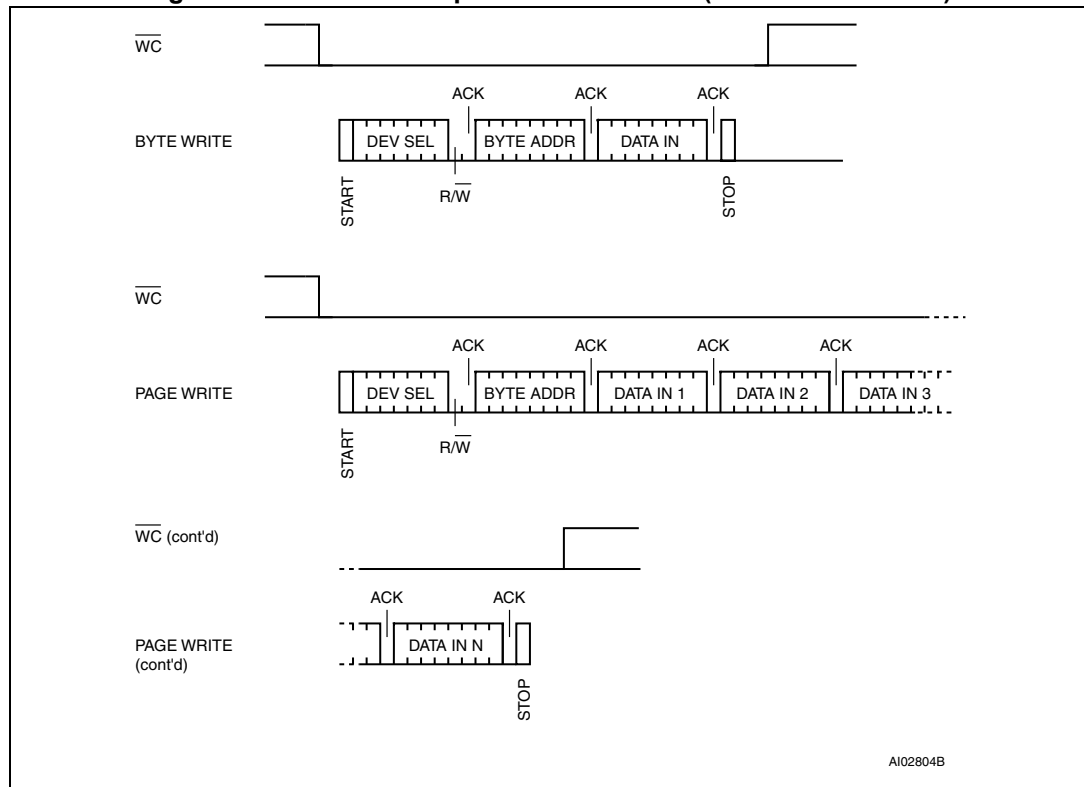
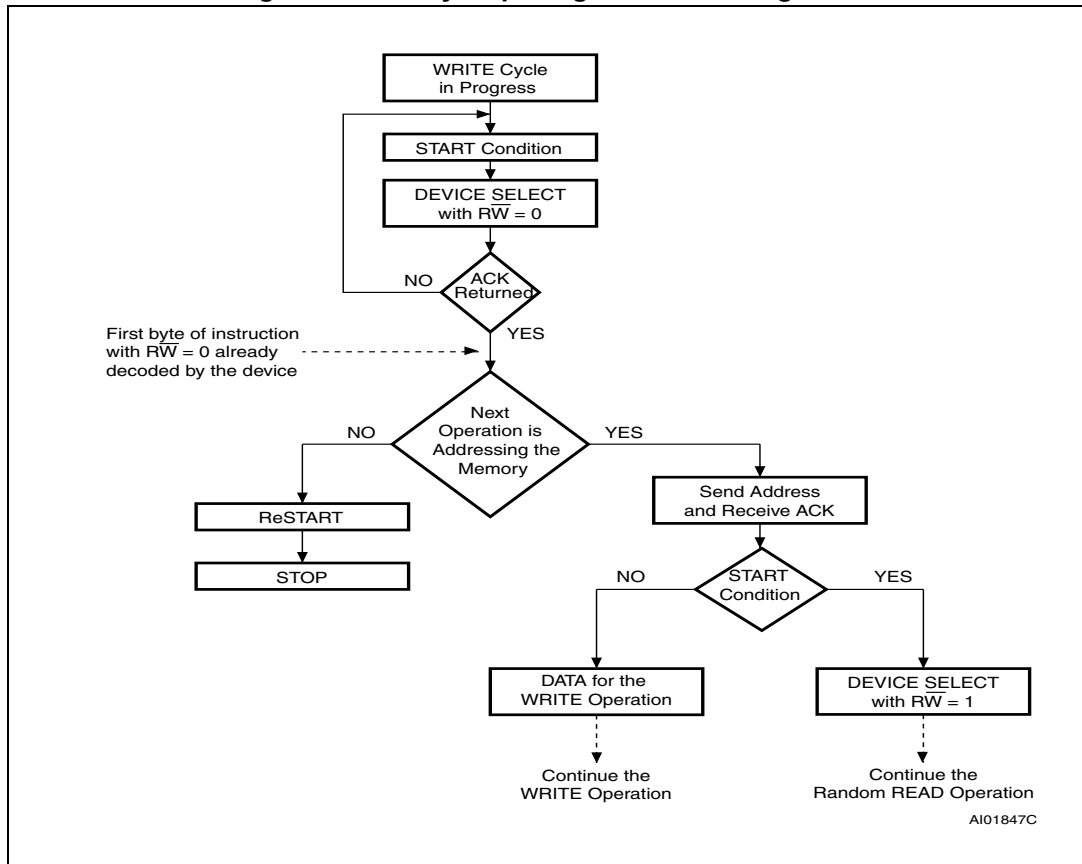

Figure 6. Write cycle polling flowchart using ACK



3.9 Minimizing system delays by polling on ACK

During the internal Write cycle, the device disconnects itself from the bus, and writes a copy of the data from its internal latches to the memory cells. The maximum Write time (t_w) is shown in [Table 9](#), but the typical time is shorter. To make use of this, a polling sequence can be used by the bus master.

The sequence, as shown in [Figure 6](#), is:

- Initial condition: a Write cycle is in progress.
- Step 1: the bus master issues a Start condition followed by a Device Select Code (the first byte of the new instruction).
- Step 2: if the device is busy with the internal Write cycle, no Ack will be returned and the bus master goes back to Step 1. If the device has terminated the internal Write cycle, it responds with an Ack, indicating that the device is ready to receive the second part of the instruction (the first byte of this instruction having been sent during Step 1).

Figure 7. Read mode sequences

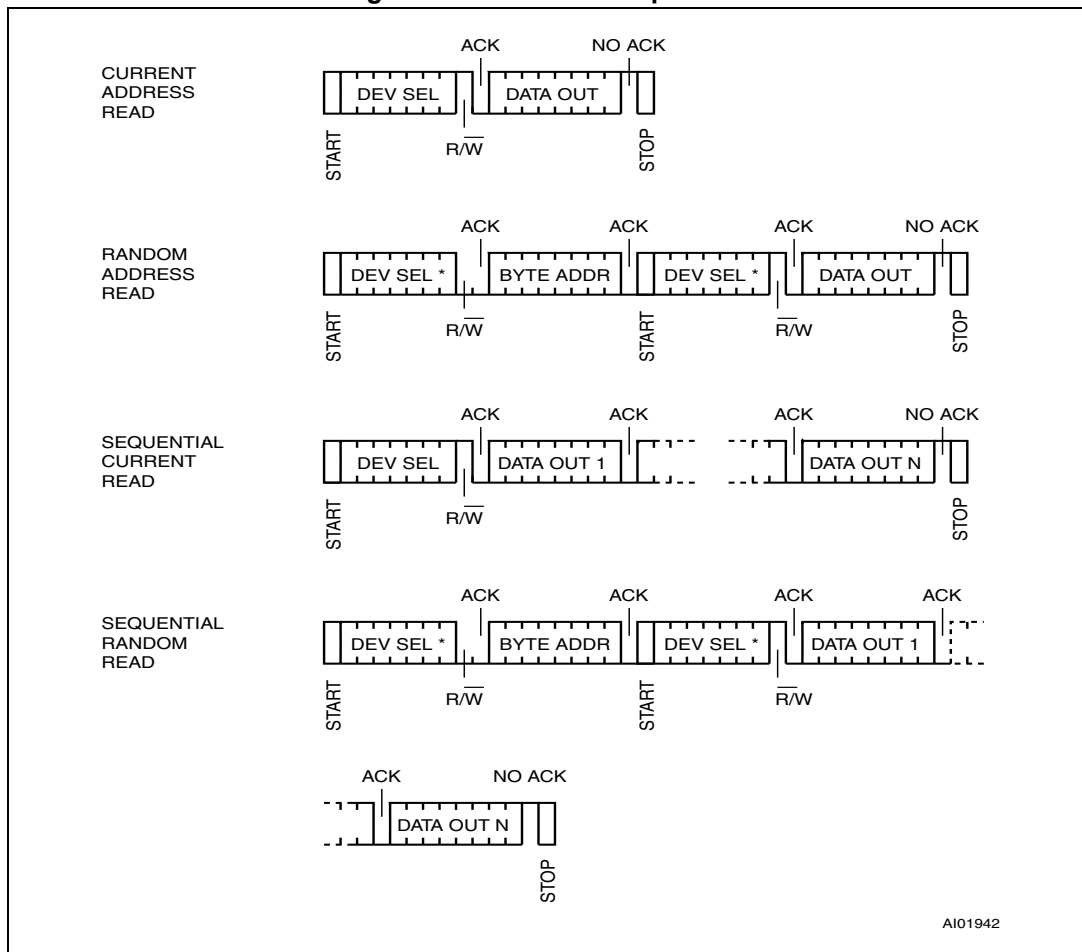

Note: The seven most significant bits of the Device Select Code of a Random Read (in the 1st and 3rd bytes) must be identical.

3.10 Read operations

Read operations are performed independently of the state of the Write Control (\overline{WC}) signal.

3.11 Random address read

A dummy Write is performed to load the address into the address counter (as shown in [Figure 7](#)) but *without* sending a Stop condition. Then, the bus master sends another Start condition, and repeats the Device Select Code, with the \overline{RW} bit set to 1. The device acknowledges this, and outputs the contents of the addressed byte. The bus master must *not* acknowledge the byte, and terminates the transfer with a Stop condition.

3.12 Current address read

The device has an internal address counter which is incremented each time a byte is read. For the Current Address Read operation, following a Start condition, the bus master only sends a Device Select Code with the RW bit set to 1. The device acknowledges this, and outputs the byte addressed by the internal address counter. The counter is then incremented. The bus master terminates the transfer with a Stop condition, as shown in [Figure 7](#), without acknowledging the byte.

3.13 Sequential read

This operation can be used after a Current Address Read or a Random Address Read. The bus master *does* acknowledge the data byte output, and sends additional clock pulses so that the device continues to output the next byte in sequence. To terminate the stream of bytes, the bus master must *not* acknowledge the last byte, and *must* generate a Stop condition, as shown in [Figure 7](#).

The output data comes from consecutive addresses, with the internal address counter automatically incremented after each byte output. After the last memory address, the address counter 'rolls-over', and the device continues to output data from memory address 00h.

3.14 Acknowledge in read mode

For all Read commands, the device waits, after each byte read, for an acknowledgment during the 9th bit time. If the bus master does not drive Serial Data (SDA) Low during this time, the device terminates the data transfer and switches to its Stand-by mode.

4 Initial delivery state

The device is delivered with all bits in the memory array set to 1 (each Byte contains FFh).

5 Maximum ratings

Stressing the device above the rating listed in the “Absolute maximum ratings” table may cause permanent damage to the device. These are stress ratings only and operation of the device at these or any other conditions above those indicated in the Operating sections of this specification is not implied. Exposure to Absolute Maximum Rating conditions for extended periods may affect device reliability.

Table 4. Absolute maximum ratings

Symbol	Parameter	Min.	Max.	Unit
T _A	Ambient Operating Temperature	-40	125	°C
T _{STG}	Storage Temperature	-65	150	°C
T _{LEAD}	Lead temperature during soldering	see note ⁽¹⁾		°C
V _{IO}	Input or Output range	-0.50	6.5	V
V _{CC}	Supply Voltage	-0.50	6.5	V
V _{ESD}	Electrostatic Discharge Voltage (Human Body model) ⁽²⁾	-3000	3000 ⁽³⁾	V

1. Compliant with JEDEC standard J-STD-020D (for small-body, Sn-Pb or Pb assembly), the ST ECOPACK[®] 7191395 specification, and the European directive on Restrictions on Hazardous Substances (RoHS directive 2011/65/EU of July 2011).

2. AEC-Q100-002 (compliant with JEDEC Std JESD22-A114A, C1=100pF, R1=1500Ω, R2=500Ω)

3. 4000 V for products identified with process letter S or G

6 DC and AC parameters

This section summarizes the operating and measurement conditions, and the DC and AC characteristics of the device. The parameters in the DC and AC Characteristic tables that follow are derived from tests performed under the Measurement Conditions summarized in the relevant tables. Designers should check that the operating conditions in their circuit match the measurement conditions when relying on the quoted parameters.

Table 5. Operating conditions

Symbol	Parameter	Min.	Max.	Unit
V_{CC}	Supply Voltage	2.5	5.5	V
T_A	Ambient Operating Temperature	-40	85	°C

Table 6. AC measurement conditions

Symbol	Parameter	Min.	Max.	Unit
C_L	Load Capacitance	100		pF
	Input Rise and Fall Times		50	ns
	Input Levels	0.2V _{CC} to 0.8V _{CC}		V
	Input and Output Timing Reference Levels	0.3V _{CC} to 0.7V _{CC}		V

Figure 8. AC measurement I/O waveform

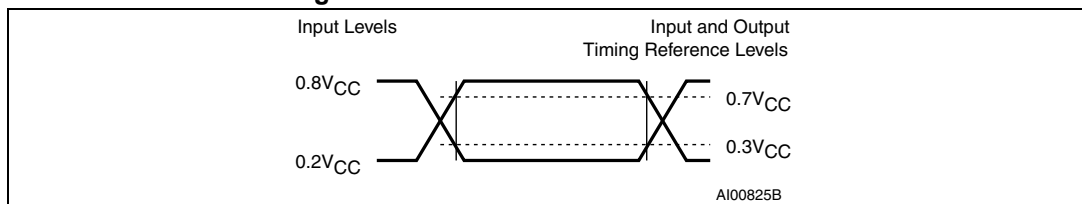

Table 7. Input parameters

Symbol	Parameter ⁽¹⁾⁽²⁾	Test condition	Min.	Max.	Unit
C_{IN}	Input Capacitance (SDA)			8	pF
C_{IN}	Input Capacitance (other pins)			6	pF
Z_{WCL}	\overline{WC} Input Impedance	$V_{IN} < 0.3V_{CC}$	5	70	k Ω
Z_{WCH}	\overline{WC} Input Impedance	$V_{IN} > 0.7V_{CCs}$	500		k Ω
t_{NS}	Pulse width ignored (Input Filter on SCL and SDA)	Single glitch		100	ns

1. $T_A = 25\text{ }^\circ\text{C}$, $f = 400\text{ kHz}$
2. Sampled only, not 100% tested.

Table 8. DC characteristics

Symbol	Parameter	Test condition (in addition to those in Table 5)	Min.	Max.	Unit
I_{LI}	Input Leakage Current (SCL, SDA)	$V_{IN} = V_{SS}$ or V_{CC}		± 2	μA
I_{LO}	Output Leakage Current	$V_{OUT} = V_{SS}$ or V_{CC} , SDA in Hi-Z		± 2	μA
I_{CC}	Supply Current	$V_{CC} = 2.5V$, $f_c = 400kHz$ (rise/fall time < 30ns)		1	mA
I_{CC1}	Stand-by Supply Current	$V_{IN} = V_{SS}$ or V_{CC} , $V_{CC} = 2.5 V$		2 ⁽¹⁾	μA
V_{IL}	Input Low Voltage (E2, E1, SCL, SDA)		-0.3	$0.3V_{CC}$	V
V_{IH}	Input High Voltage (E2, E1, SCL, SDA, \overline{WC})		$0.7V_{CC}$	$V_{CC} + 1$	V
V_{OL}	Output Low Voltage	$I_{OL} = 2.1 mA$, $V_{CC} = 2.5 V$		0.4	V

1. 0.5 μA for products identified with process letters S or G

Table 9. AC characteristics

Test conditions specified in Table 5 and Table 6					
Symbol	Alt.	Parameter	Min.	Max.	Unit
f_C	f_{SCL}	Clock Frequency		400	kHz
t_{CHCL}	t_{HIGH}	Clock Pulse Width High	600		ns
t_{CLCH}	t_{LOW}	Clock Pulse Width Low	1300		ns
$t_{DL1DL2}^{(1)}$	t_F	SDA Fall Time	20	300	ns
t_{DXCX}	$t_{SU:DAT}$	Data In Set Up Time	100		ns
t_{CLDX}	$t_{HD:DAT}$	Data In Hold Time	0		ns
t_{CLQX}	t_{DH}	Data Out Hold Time	100		ns
$t_{CLQV}^{(2)}$	t_{AA}	Clock Low to Next Data Valid (Access Time)		900	ns
$t_{CHDX}^{(3)}$	$t_{SU:STA}$	Start Condition Set Up Time	600		ns
t_{DLCL}	$t_{HD:STA}$	Start Condition Hold Time	600		ns
t_{CHDH}	$t_{SU:STO}$	Stop Condition Set Up Time	600		ns
t_{DHDL}	t_{BUF}	Time between Stop Condition and Next Start Condition	1300		ns
t_W	t_{WR}	Write Time		5	ms

1. Sampled only, not 100% tested.
2. To avoid spurious START and STOP conditions, a minimum delay is placed between SCL=1 and the falling or rising edge of SDA.
3. For a reSTART condition, or following a Write cycle.

Figure 9. AC waveforms

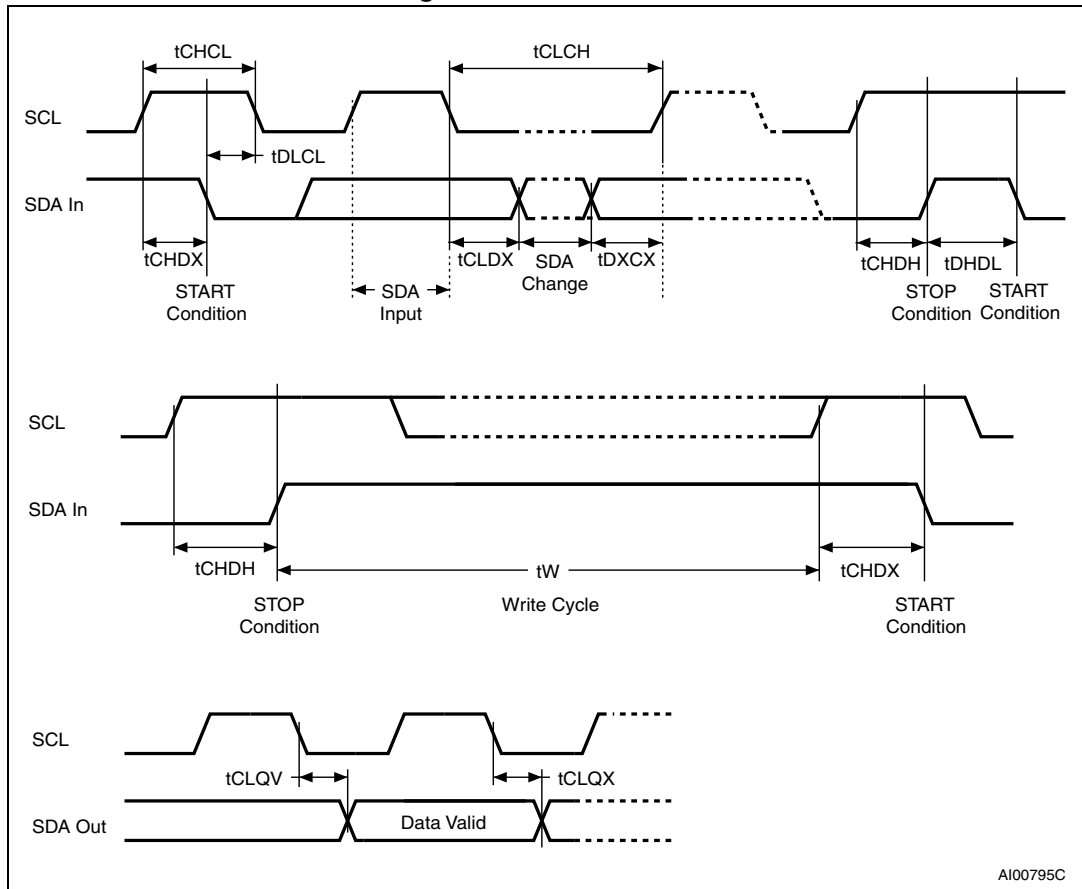

AI00795C

Figure 10. Maximum R_L value versus bus capacitance (C_{BUS}) for an I²C bus

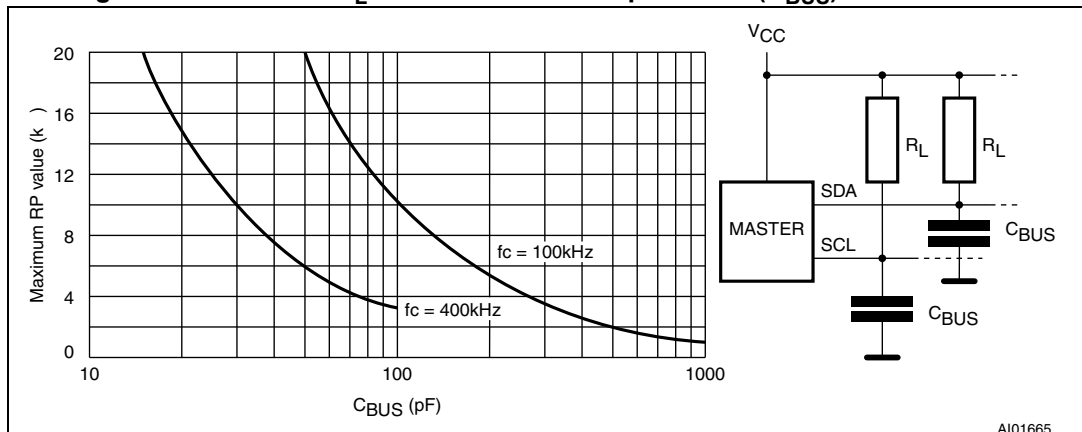

AI01665

7 Package mechanical data

In order to meet environmental requirements, ST offers these devices in different grades of ECOPACK® packages, depending on their level of environmental compliance. ECOPACK® specifications, grade definitions and product status are available at: www.st.com. ECOPACK® is an ST trademark.

7.1 SO8N package information

Figure 11. SO8N – 8-lead plastic small outline, 150 mils body width, package outline

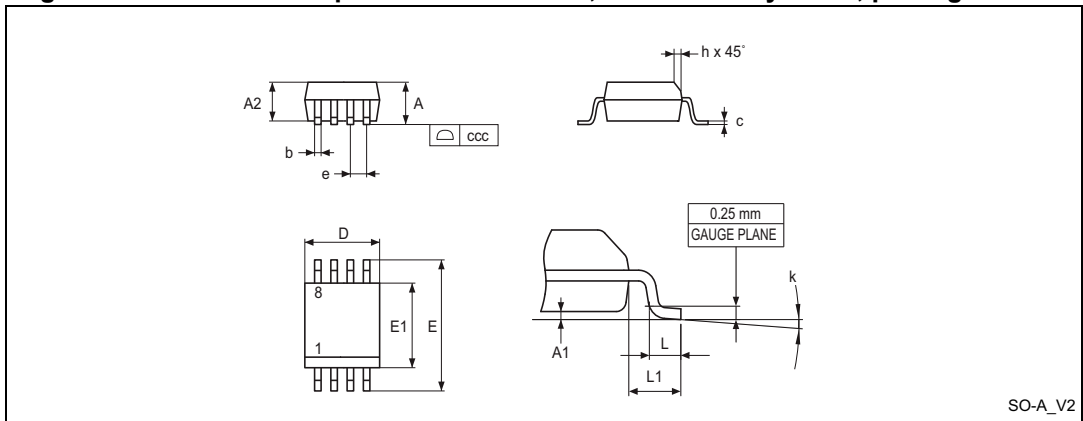

1. Drawing is not to scale.

Table 10. SO8N – 8-lead plastic small outline, 150 mils body width, package mechanical data

Symbol	millimeters			inches ⁽¹⁾		
	Min.	Typ.	Max.	Min.	Typ.	Max.
A	-	-	1.750	-	-	0.0689
A1	0.100	-	0.250	0.0039	-	0.0098
A2	1.250	-	-	0.0492	-	-
b	0.280	-	0.480	0.0110	-	0.0189
c	0.170	-	0.230	0.0067	-	0.0091
D	4.800	4.900	5.000	0.1890	0.1929	0.1969
E	5.800	6.000	6.200	0.2283	0.2362	0.2441
E1	3.800	3.900	4.000	0.1496	0.1535	0.1575
e	-	1.270	-	-	0.0500	-
h	0.250	-	0.500	0.0098	-	0.0197
k	0°	-	8°	0°	-	8°
L	0.400	-	1.270	0.0157	-	0.0500

Table 10. SO8N – 8-lead plastic small outline, 150 mils body width, package mechanical data (continued)

Symbol	millimeters			inches ⁽¹⁾		
	Min.	Typ.	Max.	Min.	Typ.	Max.
L1	-	1.040	-	-	0.0409	-
ccc	-	-	0.100	-	-	0.0039

1. Values in inches are converted from mm and rounded to four decimal digits.

Figure 12. SO8N – 8-lead plastic small outline, 150 mils body width, package recommended footprint

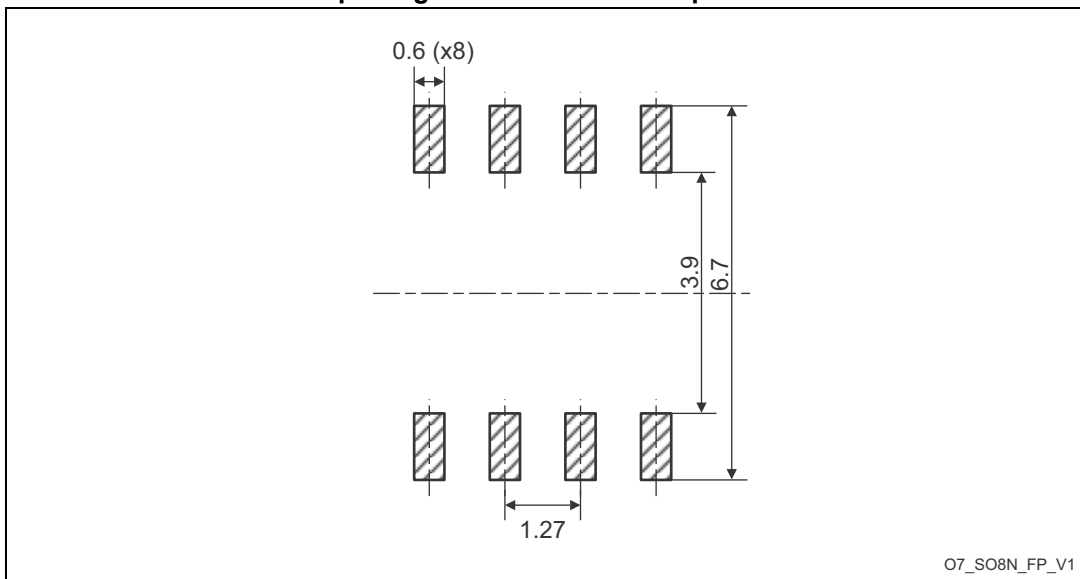

1. Dimensions are expressed in millimeters.

8 Part numbering

Table 11. Ordering information scheme

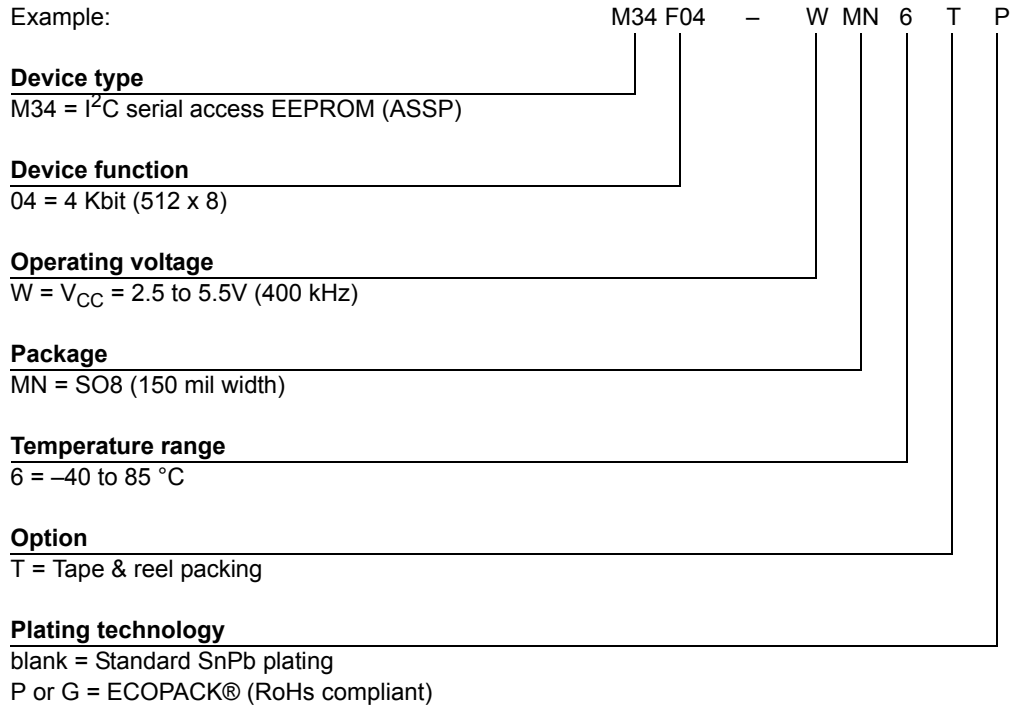

9 Revision history

Table 12. Document revision history

Date	Version	Description
23-Jan-2004	1.0	Document written
24-Jan-2006	2	Document status promoted from Preliminary data to full Datasheet. SO8 package specifications updated (see Table 10 . and Figure 12.). SO8 package is compliant with ST ECOPACK® specifications. "Power On Reset" paragraph removed from below SUMMARY DESCRIPTION . Supply voltage (VCC) paragraph added to SIGNAL DESCRIPTION section. Table 4: Absolute maximum ratings updated.
14-Feb-2013	3	Document reformatted. Updated the title and features list on cover page. Added the sentence "The upper half... \overline{WC} pin" in Section 1: Description . Moved Table 2: Device select code to Section 3.5: Memory addressing . Updated the V_{ESD} minimum/maximum values and added a note in Table 4: Absolute maximum ratings . Updated the I_{CC1} maximum value and added a note in Table 8: DC characteristics . Updated the t_{CLQX} and t_{CLQV} minimum values in Table 9: AC characteristics . Moved Figure 10: Maximum RL value versus bus capacitance (CBUS) for an I2C bus to Section 6: DC and AC parameters . Updated Figure 11: SO8N – 8-lead plastic small outline, 150 mils body width, package outline and Table 10: SO8N – 8-lead plastic small outline, 150 mils body width, package data . Moved ECOPACK mention to Section 8 . Removed notes below Table 11: Ordering information scheme .
14-May-2015	4	Updated: – Features ; – Disclaimer : Removed military warning; – Section 7: Package mechanical data ; – Figure 11: SO8N – 8-lead plastic small outline, 150 mils body width, package outline ; – Table 10: SO8N – 8-lead plastic small outline, 150 mils body width, package mechanical data Added: – T_{LEAD} inside Table 4: Absolute maximum ratings ; – Table 12: SO8N – 8-lead plastic small outline, 150 mils body width, package recommended footprint .

IMPORTANT NOTICE – PLEASE READ CAREFULLY

STMicroelectronics NV and its subsidiaries ("ST") reserve the right to make changes, corrections, enhancements, modifications, and improvements to ST products and/or to this document at any time without notice. Purchasers should obtain the latest relevant information on ST products before placing orders. ST products are sold pursuant to ST's terms and conditions of sale in place at the time of order acknowledgement.

Purchasers are solely responsible for the choice, selection, and use of ST products and ST assumes no liability for application assistance or the design of Purchasers' products.

No license, express or implied, to any intellectual property right is granted by ST herein.

Resale of ST products with provisions different from the information set forth herein shall void any warranty granted by ST for such product.

ST and the ST logo are trademarks of ST. All other product or service names are the property of their respective owners.

Information in this document supersedes and replaces information previously supplied in any prior versions of this document.

© 2015 STMicroelectronics – All rights reserved