

FACE VIEW - MALE INSERT

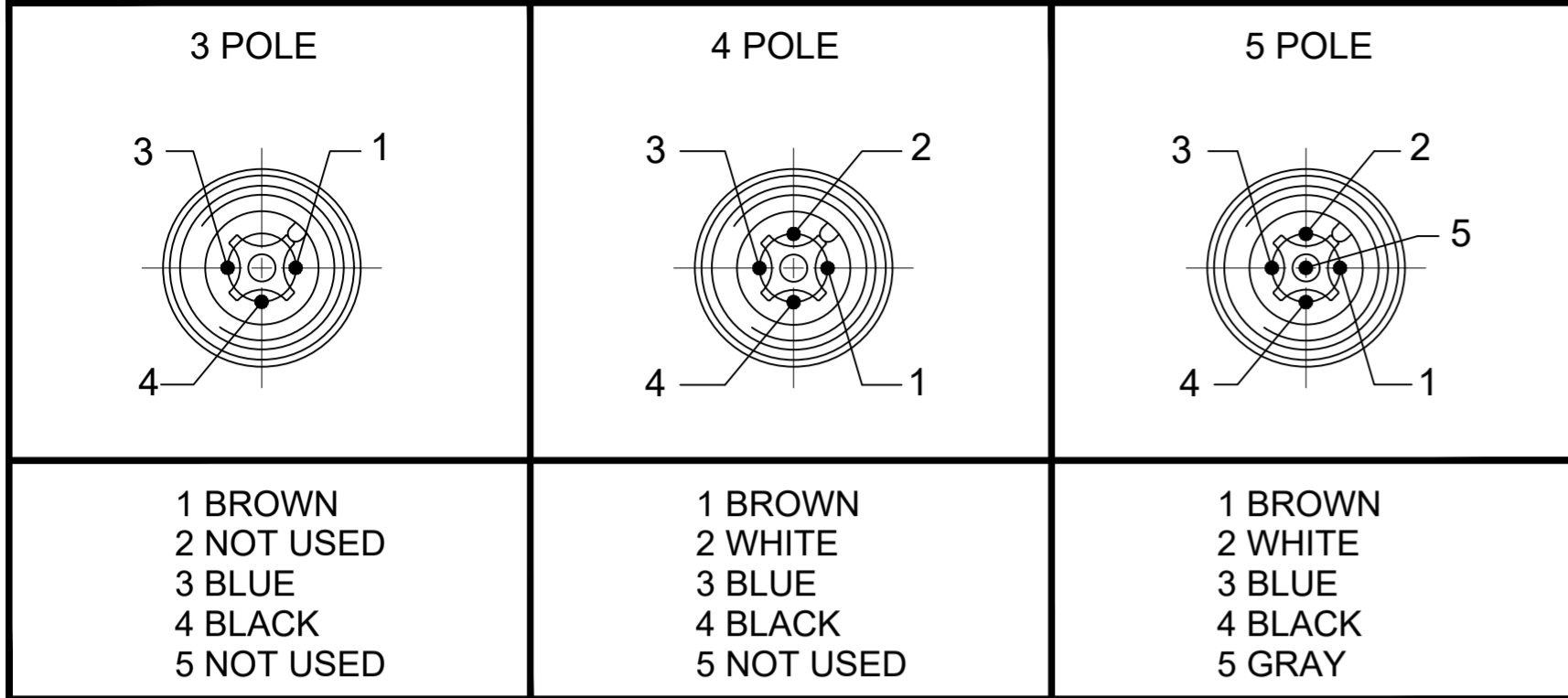

NOTES:

- MATERIAL: AS NOTED
- FINISH: AS NOTED
- ELECTRICAL:  
VOLTAGE: 250V  
CURRENT: 4A
- TEMP RATING: -20° TO +105°C (B)
- PROTECTION: IP67 (WHEN MATED)
- COUPLING THREAD: M12X1
- UL RECOGNIZED FILE: E152210  
CSA CERTIFIED FILE: LR6837
- ALL DIMENSIONS ARE FOR REFERENCE  
UNLESS TOLERANCED OR NOTED OTHERWISE

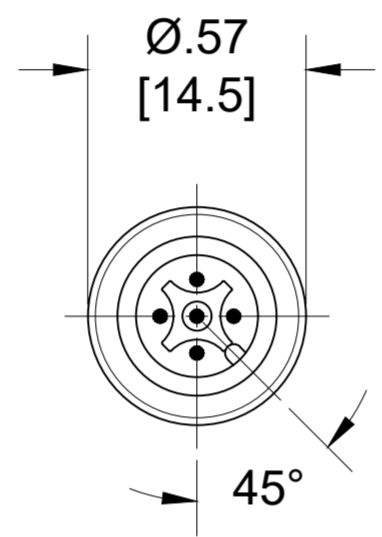

PART NO	ENGINEERING NO.	FINISHED LENGTH	POLES	CABLE DIA.
1200651113	803006K05M006	0.6M [2FT]	3	.20 [5.1]
1200652049	804006K05M150	15M [49FT 2 IN]	4	.21 [5.3]
1200652470	805006K05M300	30M [98FT 5 IN]	5	.23 [5.8]

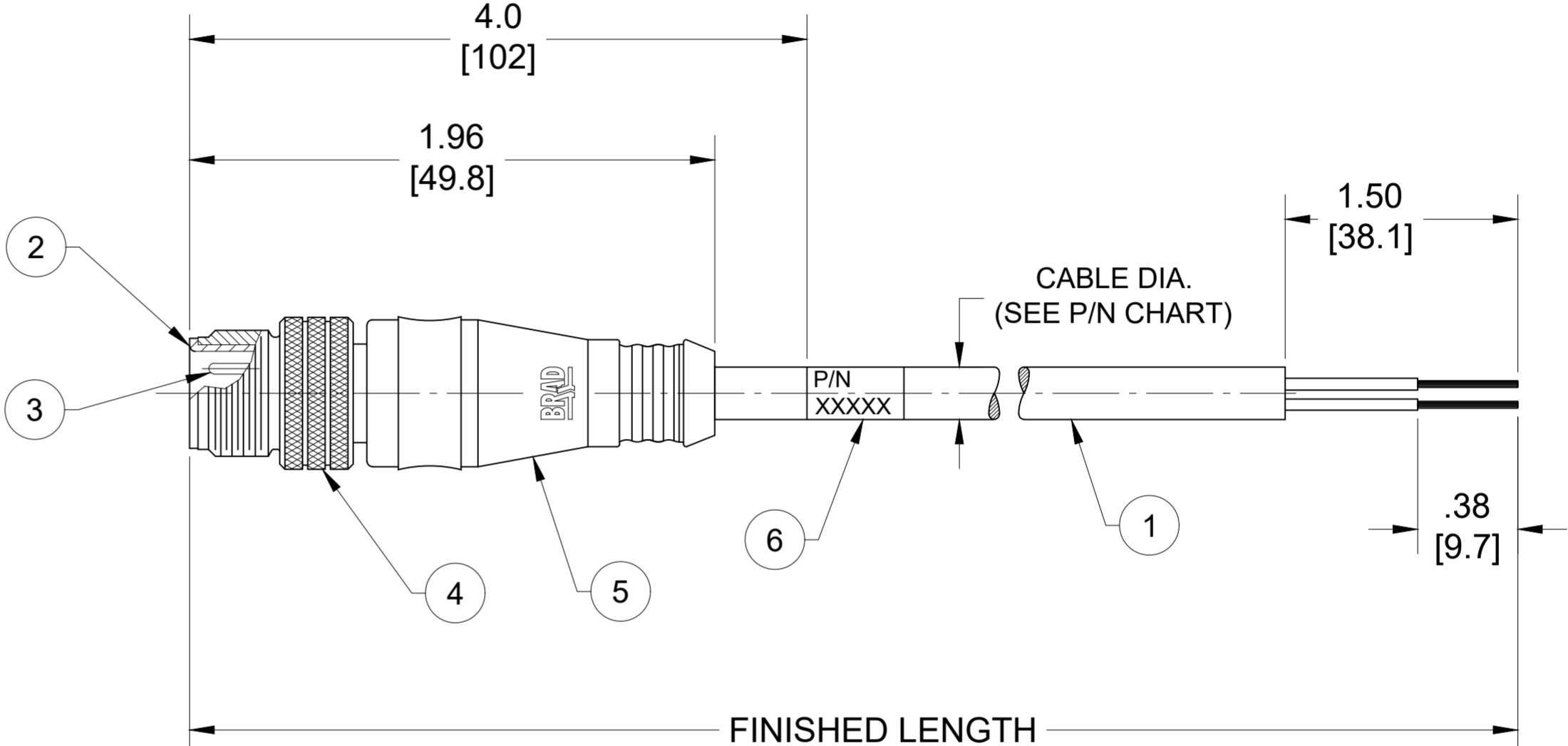

CABLE FLEX CHARACTERISTICS

TORSIONAL FLEX TEST	10 MILLION CYCLES PER MIL-C-13777G
BEND FLEX TEST	10 MILLION CYCLES PER MIL-C-13777G
WELD SLAG RESISTANCE	WOODHEAD STANDARD S-300

PART NO. MATRIX  
803006K05M006

POLES (3, 4 & 5)  
FINISHED LENGTH  
M005 = 0.5 METER  
M010 = 1 METER  
M100 = 10 METER

CABLE LENGTH TOLERANCES

<.3M [1FT]:	+19mm-0 [+ .75in-0]
.3 - .9M [1 - 3FT]:	+44.5mm-0 [+1.75in-0]
.9 - 1.8M [3 - 6FT]:	+55.6mm-0 [+2.19in-0]
1.8 - 3.7M [6 - 12FT]:	+88.9mm-0 [+3.50in-0]
3.7 - 7.3M [12 - 24FT]:	+165.1mm-0 [+6.50in-0]
7.3-14.6M [24 - 48FT]:	+317.5mm-0 [+12.50in-0]
14.6 - 30.5M [48-100FT]:	+622.3mm-0 [+24.50in-0]
OVER 30M [100FT]	+2% OF FINISHED LENGTH

ITEM	DESCRIPTION	MATERIAL	FINISH
6	WRAP LABEL	VINYL	BLACK/YELLOW
5	OVERMOLD	TPC	YELLOW
4	COUPLING NUT	BRASS	NICKEL PLATED
3	CONTACT PIN	COPPER ALLOY	GOLD OVER NICKEL
2	MALE INSERT	PUR	BLACK
1	#22 AWG CABLE	TPE JACKET	YELLOW

THIS DRAWING CONTAINS INFORMATION THAT IS PROPRIETARY TO MOLEX ELECTRONIC TECHNOLOGIES, LLC AND SHOULD NOT BE USED WITHOUT WRITTEN PERMISSION

FUNCTIONAL SYMBOLS	DIMENSION UNITS	SCALE	CURRENT REV DESC: ITEM #6 WAS TPE. MODIFIED TEMP RATING & PN CHART
FA=0	INCH/MM	NTS	
FC=0	GENERAL TOLERANCES (UNLESS SPECIFIED)		
FP=0			
DIVISIONAL SYMBOLS	mm	INCH	EC NO: 671333
	4 PLACES ±----	±----	DRWN: ABENJAMINLW 2021/04/30
	3 PLACES ±----	±----	CHK'D: RSTONE 2021/07/23
	2 PLACES ±----	±----	APPR: BWOODMAN 2021/07/28
	1 PLACE ±----	±----	INITIAL REVISION:
	0 PLACES ±----	±----	DRWN: RSTONE 2018/11/01
	ANGULAR TOL ± ---- °		APPR: BWOODMAN 2018/11/30
	DRAFT WHERE APPLICABLE MUST REMAIN WITHIN DIMENSIONS	THIRD ANGLE PROJECTION	DRAWING C-SIZE
			SERIES 120065
			MATERIAL NUMBER SEE CHART
			CUSTOMER GENERAL MARKET
			SHEET NUMBER 1 OF 1

**molex**

MICRO-CHANGE CORDSET, M12, 3-5 POLE, MALE, STRAIGHT, SINGLE KEY, #22 AWG TPE HI-FLEX

PRODUCT CUSTOMER DRAWING

DOCUMENT NUMBER: SD-120065-114  
DOC TYPE/DOC PART/REVISION: PSD 001 B