

PART NO.	BASE TYPE	DESIGN VOLTS	DESIGN WATTS	DESIGN AMPS	MSCP	FILAMENT TYPE	AVERAGE LIFE HOURS
XPR16	S.C. MINIATURE FLANGED P13.5s	15.6	10.9	0.70 ±10%	14.3 ±15%	C-2R	150

REVISIONS			
REV	DESCRIPTION	DATE	APPROVED
1	ISSUED	04/14/2003	A.S.
2	REVISED LIFE HR. MSCP & MOL, GDIA DIMENSIONS	07/11/2012	D.C.

RoHS COMPLIANT  
LEAD FREE

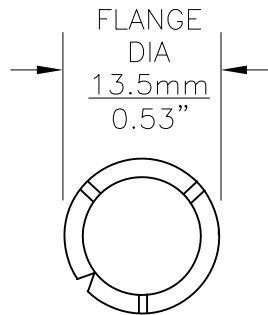

TOP VIEW

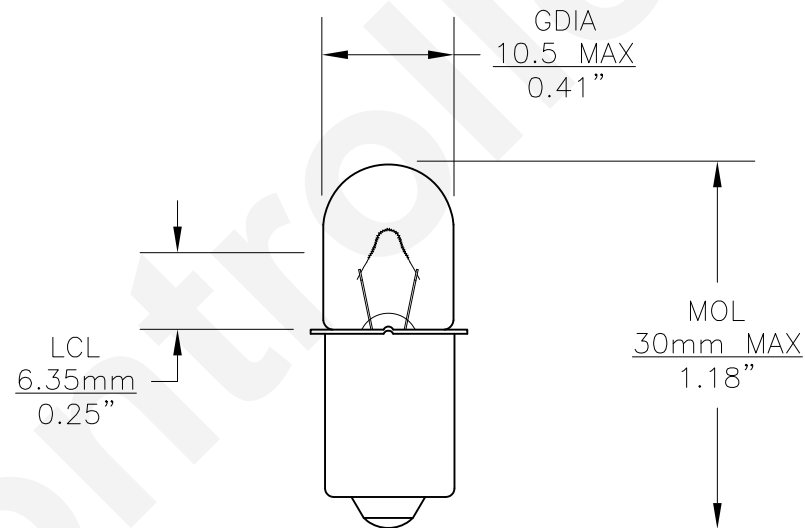

UNLESS OTHERWISE SPECIFIED: DIMENSIONS ARE IN INCHES TOLERANCES		CEC INDUSTRIES LTD			
DECIMALS .XX ± .05		599 BOND STREET		LINCOLNSHIRE, IL 60069	
ANGULAR .XXX ± .010		TITLE			
FRACTIONAL ±1/64		LIGHT BULB NO. XPR16, XENON			
DRAWN Anna Soloveychik	DATE 04/14/2003	SIZE A	FSCM NO.	DWG NO. XPR16	REV 2
CHECKED		SCALE	PLOT SCALE	SHEET 1 OF 1	
DESIGN		FILE XPR16.dwg	DO NOT SCALE DRAWING		