

Evaluating the ADL5335 Digital Variable Gain Amplifier (DGA)

FEATURES

- Full featured evaluation board for the [ADL5335](#)
- Easy connection to test equipment and other circuits
- PC control via a separately purchased system development platform [EVAL-SDP-CS1Z \(SDP-S\)](#)
- PC based evaluation software with simple graphical user interface

GENERAL DESCRIPTION

The [ADL5335](#) is a DGA that has a differential input impedance of $50\ \Omega$ and a single-ended output impedance of $50\ \Omega$. This document describes how to use the EV-ADL5335SD1Z to verify the operation of the [ADL5335](#).

The EV-ADL5335SD1Z is a fully populated, 4-layer, FR4-based evaluation board that is designed to allow the user to easily evaluate the features and performance of the [ADL5335](#). Figure 1 shows the primary side of the evaluation board.

Complete specifications for the [ADL5335](#) are available in the [ADL5335](#) data sheet from Analog Devices, Inc., and should be consulted in conjunction with this user guide when using the evaluation board.

EVALUATION BOARD PHOTOGRAPH

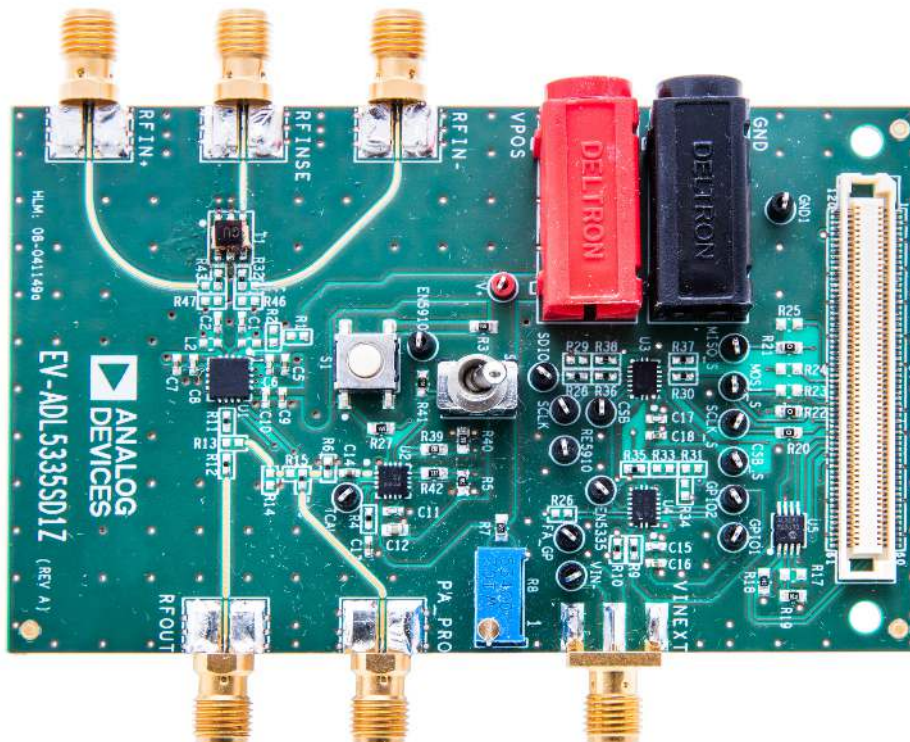

Figure 1.

16329-001

TABLE OF CONTENTS

Features	1	Fast Attack (FA) Interface	3
Test Equipment	6	Evaluation Board Software	4
General Description	1	ADL5335 Control Software INstallation.....	4
Evaluation Board Photograph.....	1	Control Software User Interface.....	4
Revision History	2	Evaluation Board Test Procedure	6
Evaluation Board Hardware	3	Test Setup.....	6
Overview.....	3	Test Procedure	6
Power Supply interface	3	Evaluation Board Schematics and Artwork.....	7
Radio Frequency (RF) Input Interface	3	Ordering information	12
RF Output Interface	3	Bill of Materials.....	12

REVISION HISTORY

11/2017—Revision 0: Initial Version

EVALUATION BOARD HARDWARE

OVERVIEW

The EV-ADL5335SD1Z supports the full functionality of the [ADL5335](#). The gain of the [ADL5335](#) is set through a USB/SDP interface and a PC-based software program. To connect the evaluation board to a PC, the [SDP-S](#) board is required and must be ordered separately.

POWER SUPPLY INTERFACE

A single 5 V supply is applied through the V+ and GND1 banana connectors to power the EV-ADL5335SD1Z. The nominal supply decoupling consists of a 0.1 μ F and 100 pF capacitor pair placed close to each device supply pin.

RADIO FREQUENCY (RF) INPUT INTERFACE

The evaluation board is configured, by default, for single-ended RF input operation, where a 50 Ω single-ended RF signal is applied to the RFIINSE SMA connector. A 1:1 impedance balun (Mini-Circuits® TCMI-63AX+) is used to match the external 50 Ω single-ended input to the 50 Ω differential input of the [ADL5335](#). This balun is specified to have a typical insertion loss of 1.3 dB.

The evaluation board can also be reconfigured for differential RF input operation by removing the R32 and R43 components and installing 37.5 Ω resistors on the R44, R45, R46, and R47 components, which are used to match the external 100 Ω differential input to the 50 Ω differential input of the [ADL5335](#). In this configuration, a 100 Ω differential RF signal input is applied through the RFIN+ and RFIN– SMA connectors.

The differential input pins of the [ADL5335](#) are ac-coupled by using 100 pF capacitors on the C1 and C2 components. The bias levels on the input pins of the [ADL5335](#) can be changed by installing inductors and resistors on the L1, L2, R1, and R2 components.

RF OUTPUT INTERFACE

The 50 Ω single-ended output of the [ADL5335](#) is available on the RFOUT SMA connector of the evaluation board. The [ADL5335](#) evaluation board also includes the [ADL5910](#) RF threshold detector, which can sense the peak envelope of power of the output of the [ADL5335](#). In the default configuration for the evaluation board, an external coupler must be used to couple the signal from the [ADL5335](#) output (RFOUT SMA connector) to the [ADL5910](#) input (PA_PRO SMA connector). An asymmetrical power splitter/coupler can be constructed on board by using the resistors on components R11 through R15 and removing R16.

FAST ATTACK (FA) INTERFACE

The threshold detector (Q) output of the [ADL5910](#) drives the FA input of the [ADL5335](#) through R42 and R5 resistors which are used for voltage level translation. When the [ADL5910](#) RF input power (and a portion of the [ADL5335](#) RF output power) exceeds the threshold level, the Q output of the [ADL5910](#) goes high and enables the FA feature of the [ADL5335](#), which allows the gain to reduce from its present setting by a pre-determined step size. The R42 resistor on the evaluation board can be removed to break the connection from the Q output of the [ADL5910](#) to the FA input of the [ADL5335](#).

The [ADL5910](#) is enabled by asserting the S2 switch on the evaluation board or applying 5 V to the EN5910 test point of the evaluation board. The [ADL5910](#) outputs can be reset by pressing the S1 push down switch. The threshold level of the [ADL5910](#) can be set by an on-board mechanical potentiometer (R8), or by applying an external threshold voltage to the VINEXT SMA connector or to the VIN– yellow test point. The TCAL yellow test point is used to determine the correct threshold voltage. Refer to the [ADL5910](#) data sheet for more information.

EVALUATION BOARD SOFTWARE

ADL5335 CONTROL SOFTWARE INSTALLATION

The ADL5335 evaluation board software is built around the Analog Devices SDP-S USB hardware and software. To install the SDP-S drivers, take the following steps.

1. Download and install the ADL5335 control software. The ADL5335 evaluation board software is available on the EV-ADL5335SD1Z webpage.
2. Within the download folder, run the SDPSDriverse.exe file. (The SDP-S board is recognized when plugged into the PC using the USB cable.)
3. Click **Next**> in the SPD drivers installation to continue the SPD drivers installation (see Figure 2).



Figure 2. SDP Drivers Setup

4. Within the SDP drivers setup wizard, choose install location, and then click **Install** (see Figure 3).

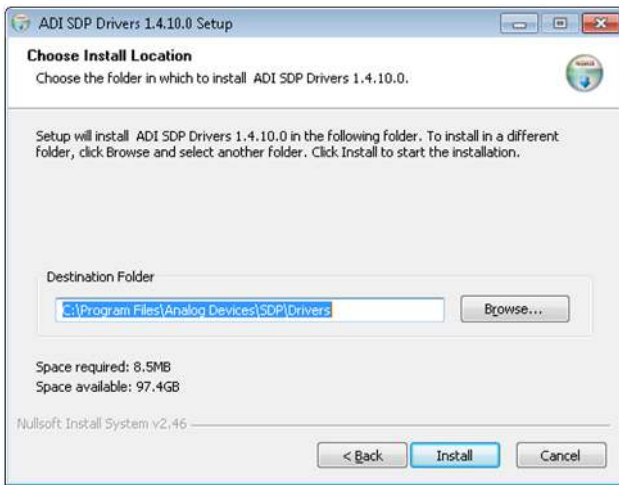

Figure 3. SDP Drivers Setup Install

5. Click **Finish** to install the SDP drivers on the PC (see Figure 4).

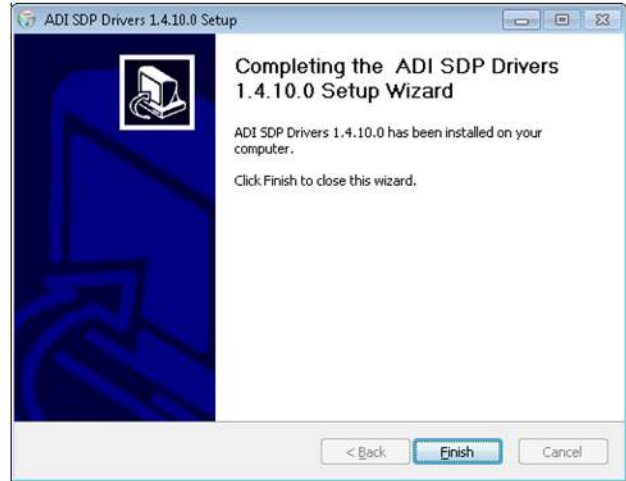

Figure 4. Finish Installation

CONTROL SOFTWARE USER INTERFACE

Run the ADL5335 Evaluation Software.exe file found in the software folder (see Figure 5). The ADL5335 control software graphic user interface (GUI) will then open (see Figure 6).

Name	Type
ADI_SDP_Writer.application	ClickOnce Applica...
ADI_SDP_Writer.exe.manifest	MANIFEST File
ADI_SDP_Writer.pdb	Program Debug D...
ADL5335 Evaluation Software.exe	Application
ADI_SDP_Writer.vshost.exe	Application
SDP_Blackfin_Base.ldr	LDR File
sdpApi1.dll	Application extens...
ADI_SDP_Writer.vshost.exe.manifest	MANIFEST File
app.publish	File folder

Figure 5. Open Evaluation Software

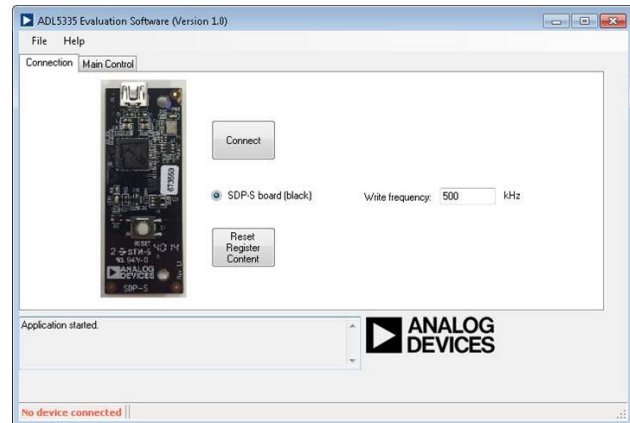

Figure 6. Evaluation Software Connection

Before using the control software, ensure that the evaluation board is connected to the controlling PC using the **SDP-S** board via a USB cable and that a 5 V power and ground are applied from a power supply unit (PSU).

After running the **ADL5335 Evaluation Software.exe** file, the graphical user interface (GUI) appears as shown in Figure 7. To establish the connection to the device, click **Connect**. The following message then appears at the bottom of the GUI: **SDP board connected. Using connector A**. This message confirms that the connection is successfully established.

To access the control register interface, select the **Main Control** tab as shown in Figure 7. The gain and fast attack levels of the DGA can be selected from the **Gain (dB)** and **Fast Attack Attenuation (dB)** drop down lists. The selected settings are programmed to the device after the **Write** button is clicked.

By default, the **ADL5335** evaluation board is configured to control fast attack mode using the control software. The **Fast Attack On/Off** button toggles the fast attack mode of the device on or off. When **Fast Attack On/Off** is first clicked, fast attack mode is activated and the RF output level is attenuated by the fast attack level already programmed to the device. Clicking **Fast Attack On/Off** once more will toggle fast attack off.

Note: Fast attack must be off when changing the fast attack attenuation level. Turning fast attack on will then attenuate the signal by the level programmed.

Register content can read by writing the hexadecimal value of the register to be read in the **Register** field and clicking the **Read** button. The current content of that register will then appear in the **Content** field.

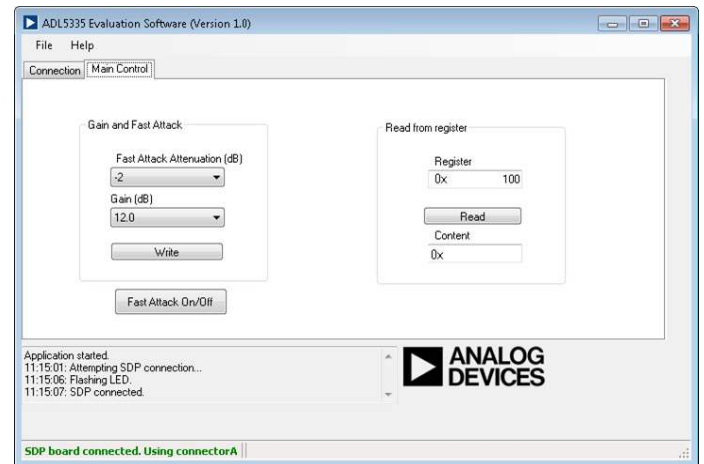

Figure 7. Evaluation Software Main Control Window

EVALUATION BOARD TEST PROCEDURE

TEST EQUIPMENT

Power supply cable of 200 mA at 5 V

RF signal generator capable of 0 dBm output at 2 GHz

Spectrum analyzer

PC with ADL5335 evaluation board software installed

EVAL-SDP-CS1Z (SDP-S) USB hardware

TEST SETUP

The ADL5335 test setup diagram is shown in Figure 8.

Use the following steps to complete the test setup:

1. Connect the power supply to V+ and GND1 banana connectors.
2. Connect the signal generator to the RFINSE SMA connector.
3. Connect the spectrum analyzer to the RFOUT SMA connector.
4. Connect the SDP-S board to the ADL5335 evaluation board and the SDP-S USB cable to the PC.

TEST PROCEDURE

Perform the following steps to complete the verification of the operation of the ADL5335.

1. Turn on the power supply to +5 V. The measured current needs to be around 125 mA.
2. Select 0 from the **Gain (dB)** drop down menu and click the **Write** button on the ADL5335 control software GUI.
3. Turn on the RF signal generator set to 0 dBm at 2 GHz.
4. On the spectrum analyzer select Center Frequency = 2 GHz, Span = 1 MHz, Attenuation = 20 dB, Reference Level = 10 dBm, and Resolution Bandwidth (RBW) = 30 kHz.
5. The RF signal can now be seen at 2 GHz. Measure the signal power level for Gain = 0 dB, using the marker function of the spectrum analyzer. The measured power must be within the range of -3 dBm to +2 dBm.
6. Select +12 from the **Gain (dB)** drop down menu and click **Write**. The difference in gain measured here and in step 5 must be +12 dB (+/- 1 dB).
7. Select +5 from the **Gain (dB)** drop down menu and click **Write**. The difference in gain measured here and in step 5 must be +5 dB (+/- 1 dB).
8. Select -2 from the **Fast Attack Attenuation (dB)** drop down menu and click the **Fast Attack On/Off** button. Verify that the gain is reduced by 2 dB from the previous value in step 7.
9. If the requirements in steps 5 through 8 are met, the device under test (DUT) has passed the test and this procedure is complete.

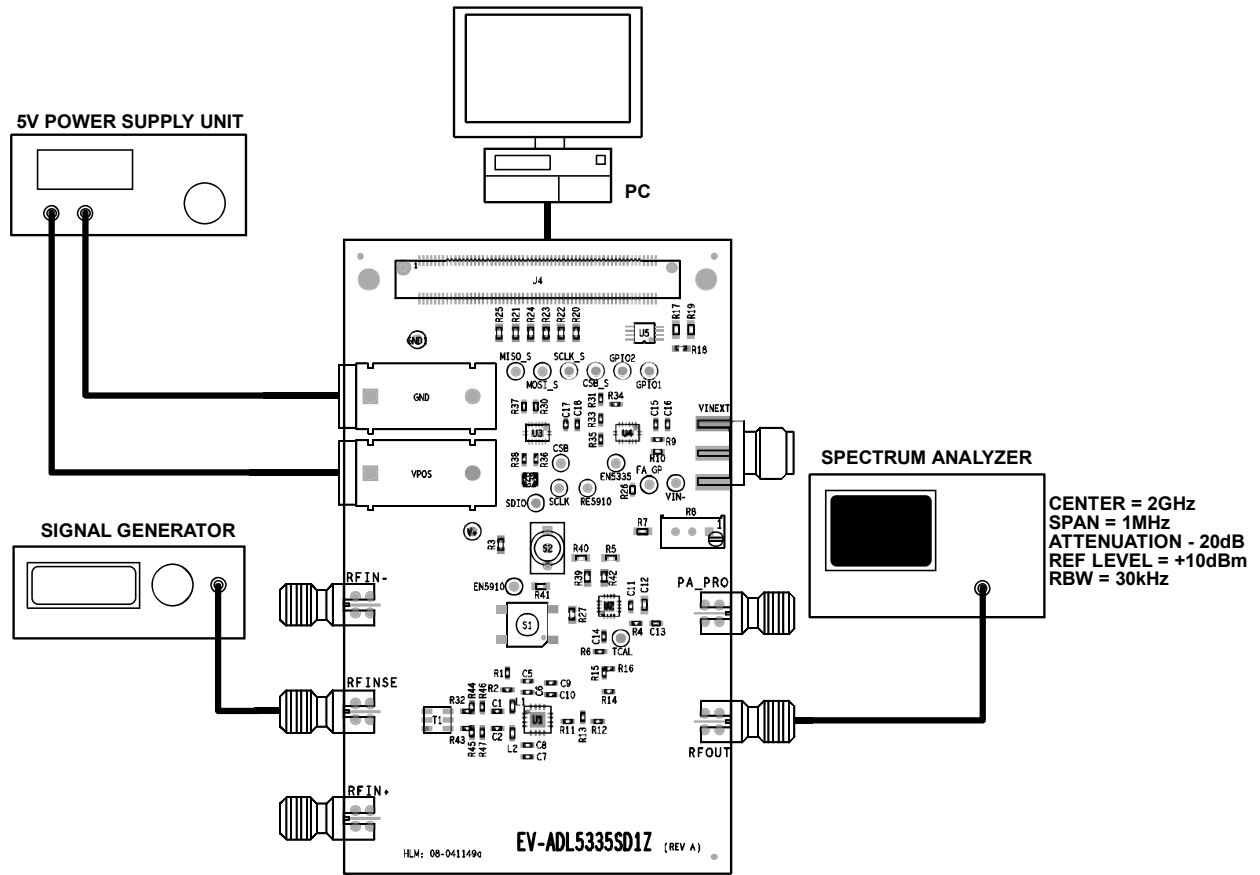

Figure 8. ADL5335 Test Setup

16329-008

EVALUATION BOARD SCHEMATICS AND ARTWORK

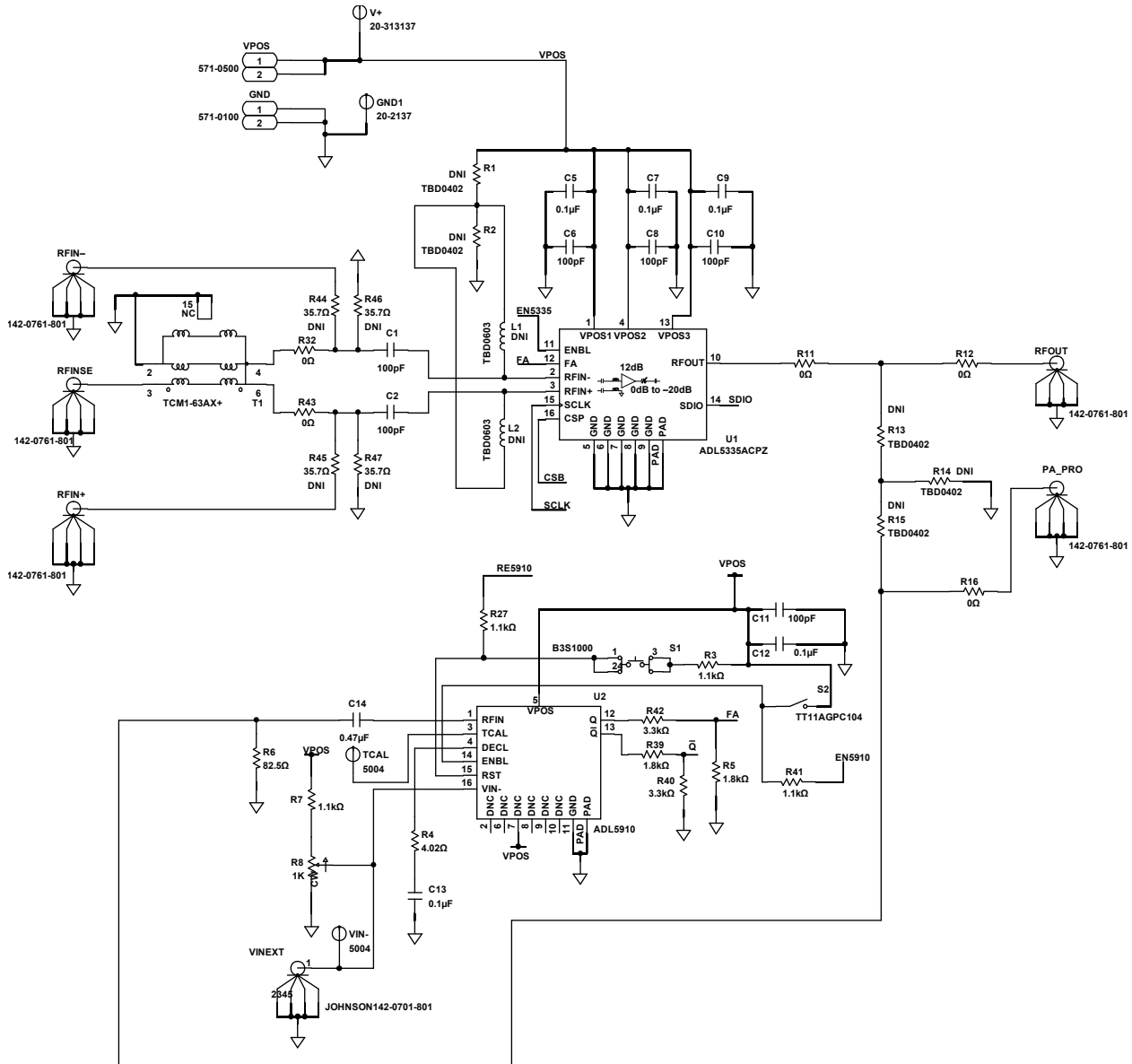

Figure 9. Evaluation Board Schematic (Main Circuit)

16329-010

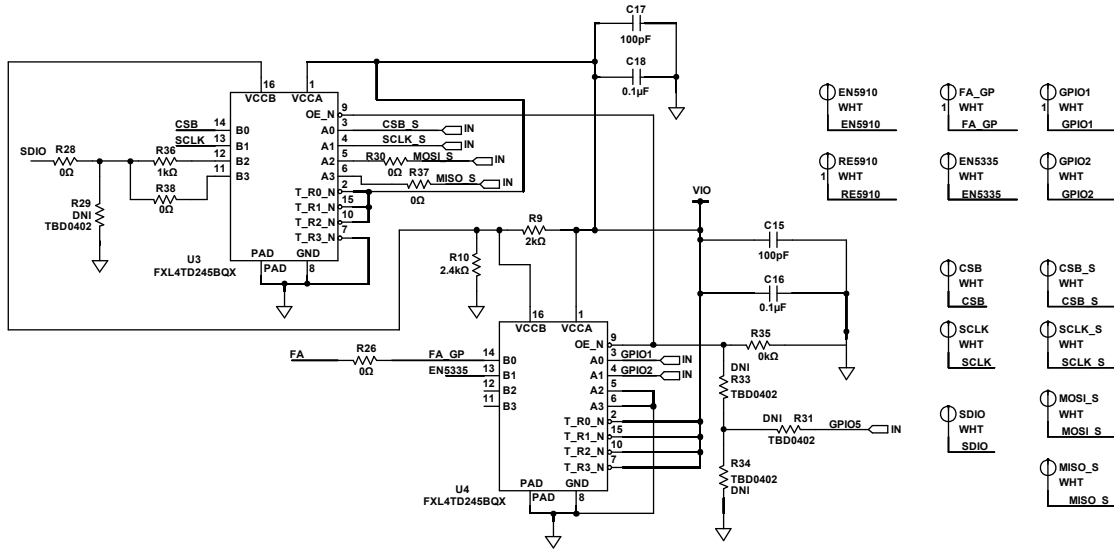

Figure 10. Evaluation Board Schematic (Main Circuit)

16329-009

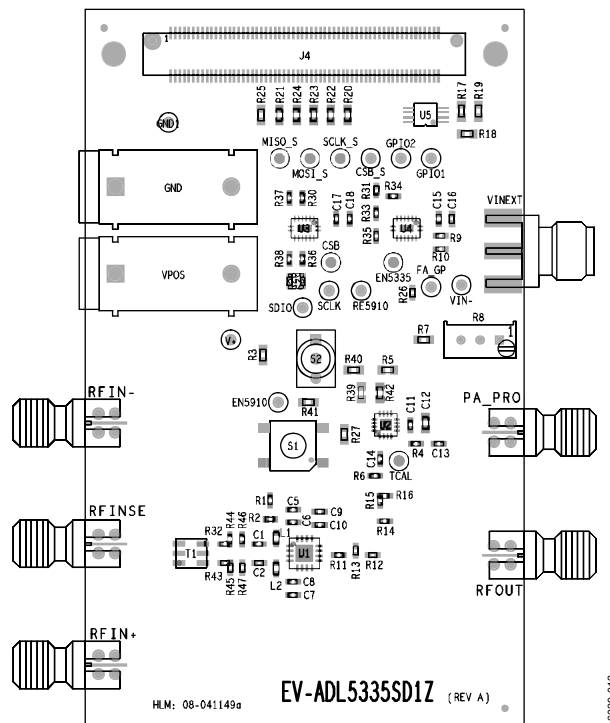

Figure 12. Evaluation Board Silk Screen

ORDERING INFORMATION

BILL OF MATERIALS

Table 1.

Qty.	Description	Reference Designator	Manufacturer	Part Number
1	Printed Circuit Board (PCB)	Not applicable	Analog Devices, Inc.	08_041149A
1	Test socket, PCB mounted, insulated socket, single, white	GND	Deltron	571-0100
1	Test socket, PCB mounted, insulated socket, single, red	VPOS	Deltron	571-0500
1	Connector, PCB test point, black	CSB, SCLK, SDIO, CSB_S, FA_GP, GPIO1, GPIO2, EN5335, EN5910, MISO_S, MOSI_S, RE5910, SCLK_S	Keystone Electronics Corp.	5001
13	Connector, PCB test point, white	CSB, SCLK, SDIO, CSB_S, FA_GP, GPIO1, GPIO2, EN5335, EN5910, MISO_S, MOSI_S, RE5910, SCLK_S	Keystone Electronics Corp.	5002
1	Connector, PCB test point, red	V+	Keystone Electronics Corp.	5000
2	Connector, PCB test point, yellow	TCAL, VIN-	Keystone Electronics Corp.	5004
1	Connector, stacking board receptacle	J4	HRS Global	FX8-120S-SV(21)
5	Connector, PCB coaxial SMA end launch	RFIN+, RFIN-, RFOUT, PA_PRO, RFINSE	Johnson Electric	142-0761-801
1	Connector, PCB coaxial SMA end launch	VINEXT	Johnson Electric	142-0701-801
8	Capacitor, SMD ceramic, C0G, 0402, 100 pF, ±5%, 50 V	C1, C2, C6, C8, C10, C11, C15, C17	Murata	GRM1555C1H101JA01D
1	Capacitor, SMD ceramic, X7R, 0603, 0.1 µF, ±10%, 50 V	C12	AVX Corp.	06035C104KAT2A
6	Capacitor, SMD ceramic, X7R, 0402, 0.1 µF ±10%, 16 V	C5, C7, C9, C13, C16, C18	Murata	GRM155R71C104KA88D
1	Capacitor, SMD ceramic, X5R, 0402, 0.47 µF ±10%, 35 V	C14	TDK Corp.	C1005X5R1V474K050BC
1	Resistor, SMD thin film chip, 0402, 2.4 kΩ, 0.1%, 1/16 W	R10	Susumu	RG1005P-242-B-T5
11	Resistor, SMD thick film chip, 0402, 0 Ω jumper, 1/10 W	R11, R12, R16, R26, R28, R30, R32, R35, R37, R38, R43	Panasonic	ERJ-2GE0R00X
2	Resistor, SMD thick film chip, 0603, 100 kΩ, 0.1%, 1/16 W	R18, R19	Multicomp	MC0063W0603110K
3	Resistor, SMD thick film chip, 0603, 0 Ω jumper, 1/16 W	R20, R21, R22	Multicomp	MC0603WG00000T5E-TC
4	Resistor, SMD thick film chip, 0603, 1.1 kΩ, 1%, 1/10 W	R3, R7, R27, R41	Bourns, Inc.	CR0603-FX-1101ELF
1	Resistor, SMD thick film chip, 0402, 1 kΩ, 1%, 1/10 W	R36	Panasonic	ERJ-2KRF1001X
2	Resistor, SMD thick film chip, 0603, 1.8 kΩ, 1%, 1/10 W	R5, R39	Yageo	RC0603FR-071K8L
1	Resistor, SMD thick film chip, 0402, 4.02 Ω, 1%, 1/16 W	R4	Vishay	CRCW04024R02FKED
2	Resistor, SMD thick film chip, 0603, 3.3 kΩ, 1%, 1/16 W	R40, R42	Multicomp	MC0063E060313K3
1	Resistor, SMD thick film chip, 0402, 82.5 Ω, 1%, 1/10 W	R6	Panasonic	ERJ-2RKF82R5X
1	Resistor, SMD thick film chip, 0402, 2 kΩ, 1%, 1/10 W	R9	Panasonic	ERJ-2RKF2001X
1	Trimmer potentiometer, 1 kΩ	R8	Bourns, Inc.	3296W-1-102LF

Qty.	Description	Reference Designator	Manufacturer	Part Number
1	Tactile switch	S1	OMRON	B3S1000
1	Toggle switch	S2	TE Connectivity, Inc.	TT11AGPC104
1	RF transformer, 50 Ω, 10 to 6000 MHz	T1	Mini-Circuits	TCMI-63AX+
1	IC, DGA, 700 MHz to 4.2 GHz	U1	Analog Devices, Inc.	ADL5335ACPZ
1	IC, envelope threshold detector/trigger, dc to 6 GHz	U2	Analog Devices, Inc.	ADL5910ACPZN-R7
2	IC, dual, 4-bit, voltage level translator	U3, U4	ON Semiconductor/ Fairchild	FXL4TD245BQZ
1	IC, 32 Kbit serial EEPROM	U5	Microchip Technology	24LC32A-I/MS



ESD Caution

ESD (electrostatic discharge) sensitive device. Charged devices and circuit boards can discharge without detection. Although this product features patented or proprietary protection circuitry, damage may occur on devices subjected to high energy ESD. Therefore, proper ESD precautions should be taken to avoid performance degradation or loss of functionality.

Legal Terms and Conditions

By using the evaluation board discussed herein (together with any tools, components documentation or support materials, the "Evaluation Board"), you are agreeing to be bound by the terms and conditions set forth below ("Agreement") unless you have purchased the Evaluation Board, in which case the Analog Devices Standard Terms and Conditions of Sale shall govern. Do not use the Evaluation Board until you have read and agreed to the Agreement. Your use of the Evaluation Board shall signify your acceptance of the Agreement. This Agreement is made by and between you ("Customer") and Analog Devices, Inc. ("ADI"), with its principal place of business at One Technology Way, Norwood, MA 02062, USA. Subject to the terms and conditions of the Agreement, ADI hereby grants to Customer a free, limited, personal, temporary, non-exclusive, non-sublicensable, non-transferable license to use the Evaluation Board FOR EVALUATION PURPOSES ONLY. Customer understands and agrees that the Evaluation Board is provided for the sole and exclusive purpose referenced above, and agrees not to use the Evaluation Board for any other purpose. Furthermore, the license granted is expressly made subject to the following additional limitations: Customer shall not (i) rent, lease, display, sell, transfer, assign, sublicense, or distribute the Evaluation Board; and (ii) permit any Third Party to access the Evaluation Board. As used herein, the term "Third Party" includes any entity other than ADI, Customer, their employees, affiliates and in-house consultants. The Evaluation Board is NOT sold to Customer; all rights not expressly granted herein, including ownership of the Evaluation Board, are reserved by ADI. CONFIDENTIALITY. This Agreement and the Evaluation Board shall all be considered the confidential and proprietary information of ADI. Customer may not disclose or transfer any portion of the Evaluation Board to any other party for any reason. Upon discontinuation of use of the Evaluation Board or termination of this Agreement, Customer agrees to promptly return the Evaluation Board to ADI. ADDITIONAL RESTRICTIONS. Customer may not disassemble, decompile or reverse engineer chips on the Evaluation Board. Customer shall inform ADI of any occurred damages or any modifications or alterations it makes to the Evaluation Board, including but not limited to soldering or any other activity that affects the material content of the Evaluation Board. Modifications to the Evaluation Board must comply with applicable law, including but not limited to the RoHS Directive. TERMINATION. ADI may terminate this Agreement at any time upon giving written notice to Customer. Customer agrees to return to ADI the Evaluation Board at that time. LIMITATION OF LIABILITY. THE EVALUATION BOARD PROVIDED HEREUNDER IS PROVIDED "AS IS" AND ADI MAKES NO WARRANTIES OR REPRESENTATIONS OF ANY KIND WITH RESPECT TO IT. ADI SPECIFICALLY DISCLAIMS ANY REPRESENTATIONS, ENDORSEMENTS, GUARANTEES, OR WARRANTIES, EXPRESS OR IMPLIED, RELATED TO THE EVALUATION BOARD INCLUDING, BUT NOT LIMITED TO, THE IMPLIED WARRANTY OF MERCHANTABILITY, TITLE, FITNESS FOR A PARTICULAR PURPOSE OR NON-INFRINGEMENT OF INTELLECTUAL PROPERTY RIGHTS. IN NO EVENT WILL ADI AND ITS LICENSORS BE LIABLE FOR ANY INCIDENTAL, SPECIAL, INDIRECT, OR CONSEQUENTIAL DAMAGES RESULTING FROM CUSTOMER'S POSSESSION OR USE OF THE EVALUATION BOARD, INCLUDING BUT NOT LIMITED TO LOST PROFITS, DELAY COSTS, LABOR COSTS OR LOSS OF GOODWILL. ADI'S TOTAL LIABILITY FROM ANY AND ALL CAUSES SHALL BE LIMITED TO THE AMOUNT OF ONE HUNDRED US DOLLARS (\$100,000). EXPORT. Customer agrees that it will not directly or indirectly export the Evaluation Board to another country, and that it will comply with all applicable United States federal laws and regulations relating to exports. GOVERNING LAW. This Agreement shall be governed by and construed in accordance with the substantive laws of the Commonwealth of Massachusetts (excluding conflict of law rules). Any legal action regarding this Agreement will be heard in the state or federal courts having jurisdiction in Suffolk County, Massachusetts, and Customer hereby submits to the personal jurisdiction and venue of such courts. The United Nations Convention on Contracts for the International Sale of Goods shall not apply to this Agreement and is expressly disclaimed.

©2017 Analog Devices, Inc. All rights reserved. Trademarks and registered trademarks are the property of their respective owners.
UG16329-0-11/17(0)



www.analog.com