

FEATURES

- Adjustable Pushbutton Debounce and Delay Timers
- Low Supply Current: 6 μ A
- Wide Operating Voltage Range: 2.7V to 26.4V
- EN Output (LTC2951-1) Allows DC/DC Converter Control
- $\overline{\text{EN}}$ Output (LTC2951-2) Allows Circuit Breaker Control
- Simple Interface Allows Graceful μ P Shutdown
- High Input Voltage PB Pin with Internal Pull-Up Resistor
- ± 10 kV ESD HBM on $\overline{\text{PB}}$ Input
- Accurate 0.6V Threshold on KILL Comparator Input
- 8-Pin 3mm \times 2mm DFN and ThinSOT™ Packages

APPLICATIONS

- Portable Instrumentation Meters
- Blade Servers
- Portable Customer Service PDA
- Desktop and Notebook Computers

DESCRIPTION

The LTC[®]2951 is a micropower, wide input voltage range pushbutton ON/OFF controller. The part contains a pushbutton input which controls the toggling of an open-drain enable output. The pushbutton turn OFF debounce time is externally programmable, while the turn ON debounce time is fixed at 128ms. A simple microprocessor interface allows for proper system housekeeping prior to power-down. Under system fault conditions, an adjustable KILL timeout delay ensures proper power-down.

The LTC2951 operates over a 2.7V to 26.4V input voltage range to accommodate a variety of input power supplies. Very low quiescent current (6 μ A typical) makes the LTC2951 ideally suited for battery powered applications. Two versions of the part are available to accommodate either positive or negative enable polarities. The parts are available in 8-pin 3mm \times 2mm DFN and ThinSOT packages.

LT, LT, LTC, LTM, Linear Technology and the Linear logo are registered trademarks and ThinSOT and PowerPath are trademarks of Linear Technology Corporation. All other trademarks are the property of their respective owners.

TYPICAL APPLICATION

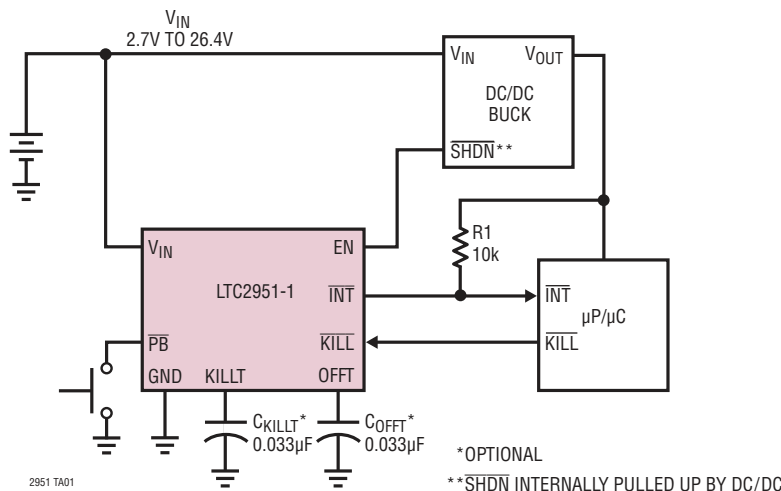

Turn-On Debounce

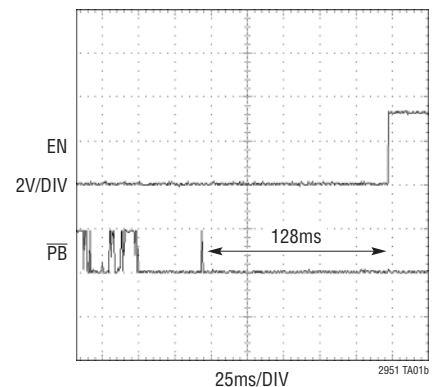

LTC2951-1/LTC2951-2

ABSOLUTE MAXIMUM RATINGS (Note 1)

Supply Voltage (V_{IN})	-0.3V to 33V	Operating Temperature Range	
Input Voltages		LTC2951C-1	0°C to 70°C
\overline{PB}	-6V to 33V	LTC2951C-2	0°C to 70°C
KILLT	-0.3V to 2.7V	LTC2951I-1	-40°C to 85°C
OFFT	-0.3V to 2.7V	LTC2951I-2	-40°C to 85°C
\overline{KILL}	-0.3V to 7V	Storage Temperature Range	
Output Voltages		DFN Package	-65°C to 125°C
\overline{INT}	-0.3V to 10V	TSOT-23	-65°C to 150°C
$\overline{EN/EN}$	-0.3V to 10V	Lead Temperature (Soldering, 10 sec)	300°C

PIN CONFIGURATION

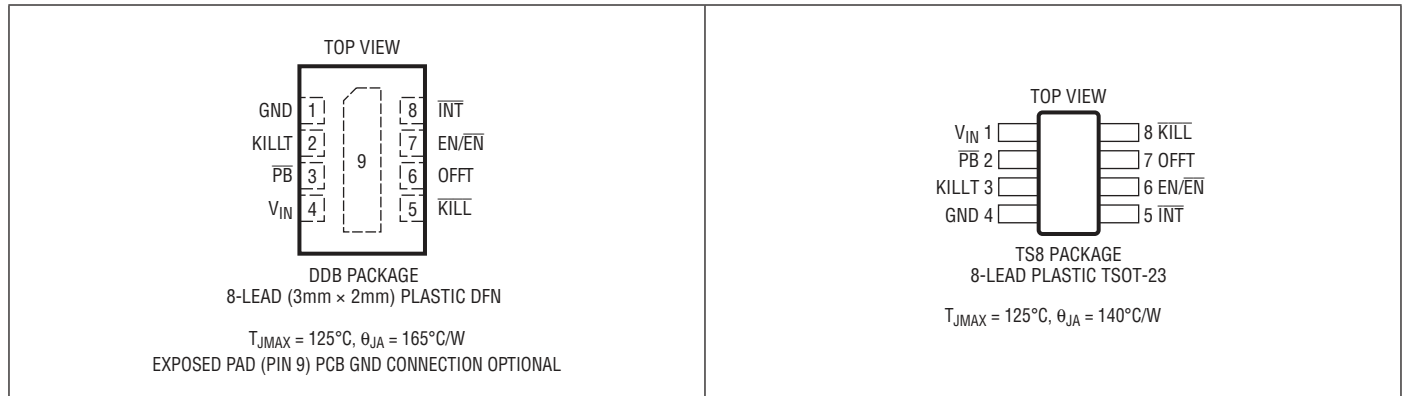

ORDER INFORMATION

LEAD FREE FINISH	TAPE AND REEL	PART MARKING*	PACKAGE DESCRIPTION	TEMPERATURE RANGE
LTC2951CDDB-1#PBF	LTC2951CDDB-1#TRPBF	LBTB	8-Lead (3mm × 2mm) Plastic DFN	0°C to 70°C
LTC2951CDDB-2#PBF	LTC2951CDDB-2#TRPBF	LBDT	8-Lead (3mm × 2mm) Plastic DFN	0°C to 70°C
LTC2951IDDB-1#PBF	LTC2951IDDB-1#TRPBF	LBTB	8-Lead (3mm × 2mm) Plastic DFN	-40°C to 85°C
LTC2951IDDB-2#PBF	LTC2951IDDB-2#TRPBF	LBDT	8-Lead (3mm × 2mm) Plastic DFN	-40°C to 85°C
LTC2951CTS8-1#PBF	LTC2951CTS8-1#TRPBF	LTBTC	8-Lead Plastic TSOT	0°C to 70°C
LTC2951CTS8-2#PBF	LTC2951CTS8-2#TRPBF	LTBTF	8-Lead Plastic TSOT	0°C to 70°C
LTC2951ITS8-1#PBF	LTC2951ITS8-1#TRPBF	LTBTC	8-Lead Plastic TSOT	-40°C to 85°C
LTC2951ITS8-2#PBF	LTC2951ITS8-2#TRPBF	LTBTF	8-Lead Plastic TSOT	-40°C to 85°C

Consult LTC Marketing for parts specified with wider operating temperature ranges. *The temperature grade is identified by a label on the shipping container.

For more information on lead free part marking, go to: <http://www.linear.com/leadfree/>

For more information on tape and reel specifications, go to: <http://www.linear.com/tapeandree/>

ELECTRICAL CHARACTERISTICS

The ● denotes the specifications which apply over the full operating temperature range, otherwise specifications are at $T_A = 25^\circ\text{C}$. $V_{IN} = 2.7\text{V}$ to 26.4V , unless otherwise noted. (Note 2)

SYMBOL	PARAMETER	CONDITIONS	MIN	TYP	MAX	UNITS
V_{IN}	Supply Voltage Range	Steady-State Operation	● 2.7		26.4	V
I_{IN}	V_{IN} Supply Current	System Power-On, $V_{IN} = 2.7\text{V}$ to 24V	●	6	12	μA
V_{UVL}	V_{IN} Undervoltage Lockout	V_{IN} Falling	● 2.2	2.3	2.4	V
$V_{UVL(HYST)}$	V_{IN} Undervoltage Lockout Hysteresis		● 50	300	600	mV

Pushbutton, Enable ($\overline{\text{PB}}$, $\text{EN}/\overline{\text{EN}}$)

$V_{\overline{\text{PB}}}(\text{MIN, MAX})$	$\overline{\text{PB}}$ Voltage Range	Single-Ended	● -1		26.4	V
$I_{\overline{\text{PB}}}$	$\overline{\text{PB}}$ Input Current	$2.5\text{V} < V_{\overline{\text{PB}}} < 26.4\text{V}$ $V_{\overline{\text{PB}}} = 1\text{V}$ $V_{\overline{\text{PB}}} = 0.6\text{V}$	● -1 ● -3	-6 -9	± 1 -12 -15	μA μA μA
$V_{\overline{\text{PB}}}(\text{VTH})$	$\overline{\text{PB}}$ Input Threshold	$\overline{\text{PB}}$ Falling	● 0.6	0.8	1	V
$t_{\text{EN}/\overline{\text{EN}}}$, Lockout	$\text{EN}/\overline{\text{EN}}$ Lockout Time (Note 5)	Enable Released \rightarrow Enable Asserted	● 200	256	325	ms
$I_{\text{EN}/\overline{\text{EN}}}(\text{LKG})$	$\text{EN}/\overline{\text{EN}}$ Leakage Current	$V_{\text{EN}/\overline{\text{EN}}} = 1\text{V}$, Sink Current Off	●		± 0.1	μA
$V_{\text{EN}/\overline{\text{EN}}}(\text{VOL})$	$\text{EN}/\overline{\text{EN}}$ Voltage Output Low	$I_{\text{EN}/\overline{\text{EN}}} = 3\text{mA}$	●	0.11	0.4	V
$V_{\overline{\text{PB}}}(\text{VOC})$	$\overline{\text{PB}}$ Open-Circuit Voltage	$I_{\overline{\text{PB}}} = -1\mu\text{A}$	● 1	1.6	2	V

Timing Pins (KILLT , OFFT)

$I_{\text{KILLT, OFFT}}(\text{PU})$	KILLT/OFFT Pull-Up Current	$V_{\text{KILLT, OFFT}} = 0\text{V}$	● -2.4	-3	-3.6	μA
$I_{\text{KILLT, OFFT}}(\text{PD})$	KILLT/OFFT Pull-Down Current	$V_{\text{KILLT, OFFT}} = 1.3\text{V}$	● 2.4	3	3.6	μA
$t_{\text{DB, ON}}$	Turn-On Debounce Time	$\overline{\text{PB}}$ Falling \rightarrow Enable Asserted	● 100	128	163	ms
$t_{\text{DB, OFF}}$	Internal Turn-Off Debounce Time	OFFT Pin Float, $\overline{\text{PB}}$ Falling \rightarrow $\overline{\text{INT}}$ Falling	● 26	32	41	ms
t_{OFFT}	Additional Adjustable Turn-Off Time	$C_{\text{OFFT}} = 1500\text{pF}$	● 9	11.5	13.5	ms

μP Handshake Pins ($\overline{\text{INT}}$, KILL)

$I_{\overline{\text{INT}}}(\text{LKG})$	$\overline{\text{INT}}$ Leakage Current	$V_{\overline{\text{INT}}} = 3\text{V}$	●		± 1	μA
$V_{\overline{\text{INT}}}(\text{VOL})$	$\overline{\text{INT}}$ Output Voltage Low	$I_{\overline{\text{INT}}} = 3\text{mA}$	●	0.11	0.4	V
$V_{\overline{\text{KILL}}}(\text{TH})$	$\overline{\text{KILL}}$ Input Threshold Voltage	$\overline{\text{KILL}}$ Falling	● 0.57	0.6	0.63	V
$V_{\overline{\text{KILL}}}(\text{HYST})$	$\overline{\text{KILL}}$ Input Threshold Hysteresis		● 10	30	50	mV
$I_{\overline{\text{KILL}}}(\text{LKG})$	$\overline{\text{KILL}}$ Leakage Current	$V_{\overline{\text{KILL}}} = 0.6\text{V}$	●		± 0.1	μA
$t_{\overline{\text{KILL}}}(\text{PW})$	$\overline{\text{KILL}}$ Minimum Pulse Width		● 30			μs
$t_{\overline{\text{KILL}}}(\text{PD})$	$\overline{\text{KILL}}$ Propagation Delay	$\overline{\text{KILL}}$ Falling \rightarrow Enable Released	●		30	μs
$t_{\overline{\text{KILL}}}$, ON BLANK	$\overline{\text{KILL}}$ Turn-On Blanking (Note 3)	$\overline{\text{KILL}} = \text{Low}$, Enable Asserted \rightarrow Enable Released	● 400	512	650	ms
$t_{\overline{\text{KILL}}}$, OFF DELAY	Internal $\overline{\text{KILL}}$ Turn-Off Delay (Note 4)	KILLT Pin Float, $\overline{\text{KILL}} = \text{High}$, $\overline{\text{INT}}$ Asserted \rightarrow Enable Released	● 100	128	163	ms
$t_{\overline{\text{KILL}}}$, OFF DELAY, ADDITIONAL	Additional Adjustable $\overline{\text{KILL}}$ Turn-Off Delay (Note 4)	$C_{\text{KILLT}} = 1500\text{pF}$	● 9	11.5	13.5	ms

Note 1: Stresses beyond those listed under Absolute Maximum Ratings may cause permanent damage to the device. Exposure to any Absolute Maximum Rating condition for extended periods may affect device reliability and lifetime.

Note 2: All currents into pins are positive; all voltages are referenced to GND unless otherwise noted.

Note 3: The $\overline{\text{KILL}}$ turn-on blanking timer period is the waiting period immediately after the enable output is asserted. This blanking time allows sufficient time for the DC/DC converter and the μP to perform power-up tasks. The KILL and $\overline{\text{PB}}$ inputs are ignored during this period. If $\overline{\text{KILL}}$ remains low at the end of this time period, the enable output is released, thus turning off system power. This time delay does not include $t_{\text{DB, ON}}$.

Note 4: The internal $\overline{\text{KILL}}$ turn-off delay ($t_{\overline{\text{KILL}}}$, OFF DELAY) is the default delay from the initiation of a power-off sequence ($\overline{\text{INT}}$ falling, $\overline{\text{KILL}} = \text{high}$), to the release of the enable output. The additional, adjustable $\overline{\text{KILL}}$ turn-off delay ($t_{\overline{\text{KILL}}}$, OFF DELAY, ADDITIONAL) uses an optional external capacitor (C_{KILLT}) to provide extra delay from $\overline{\text{INT}}$ falling to the release of the enable output. If the $\overline{\text{KILL}}$ input switches low at any time during $\overline{\text{KILL}}$ turn-off delay, enable is released, thus turning off system power.

Note 5: The enable lockout time is designed to allow an application to properly power down such that the next power-up sequence starts from a consistent powered down configuration. $\overline{\text{PB}}$ is ignored during this lockout time. This time delay does not include $t_{\text{DB, ON}}$.

TYPICAL PERFORMANCE CHARACTERISTICS

Supply Current vs Temperature

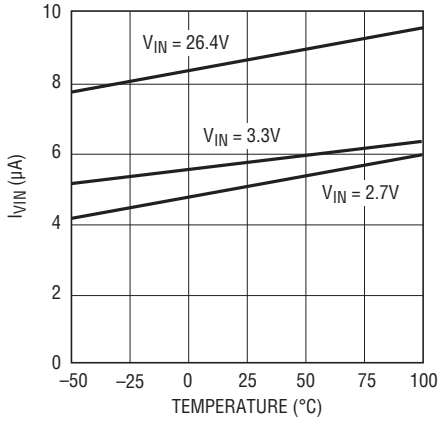

2951 G01

Supply Current vs Supply Voltage

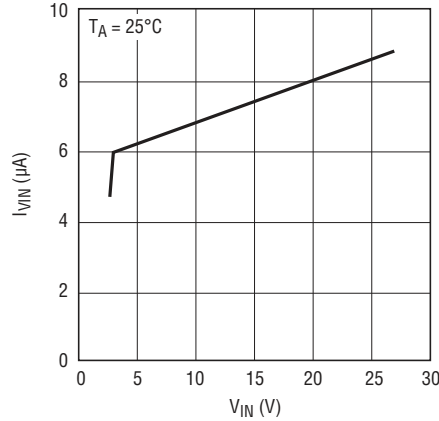

2951 G02

Turn-On Debounce Time ($t_{DB, ON}$) vs V_{IN}

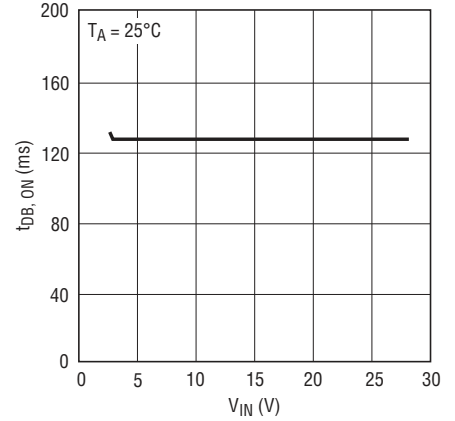

2951 G03

Internal Default Turn-Off Debounce Time ($t_{DB, OFF}$) vs V_{IN}

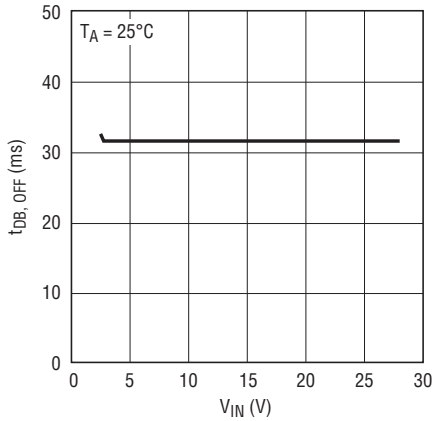

2951 G04

Turn-Off Debounce Time ($t_{DB, OFF} + t_{OFFT}$) vs OFFT External Capacitor

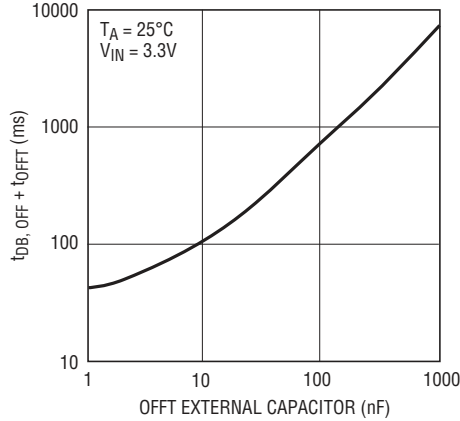

2951 G05

OFFT Pull-Down Current vs Temperature

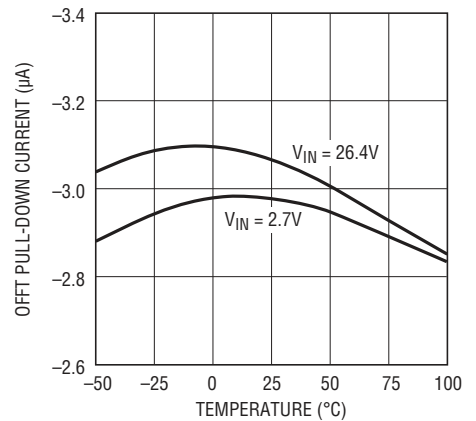

2951 G06

Internal Default KILL Turn-Off Delay ($t_{KILL, OFF DELAY}$) vs V_{IN}

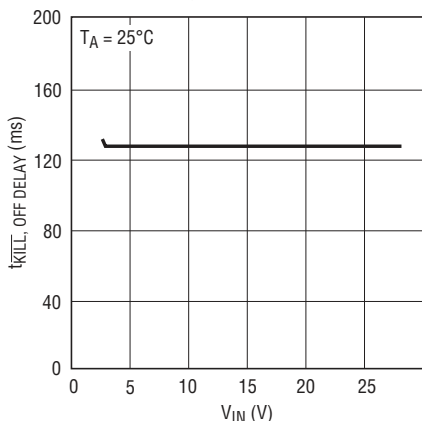

2951 G07

KILL Turn-Off Delay vs KILLT External Capacitor

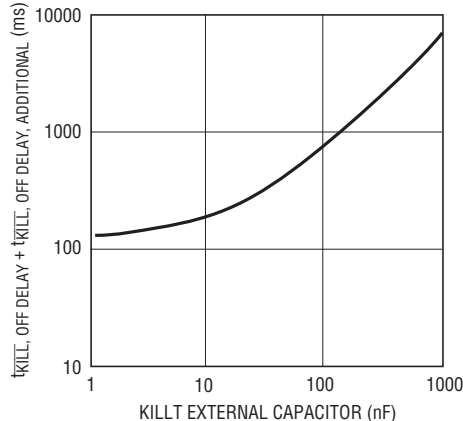

2951 G08

KILLT Pull-Down Current vs Temperature

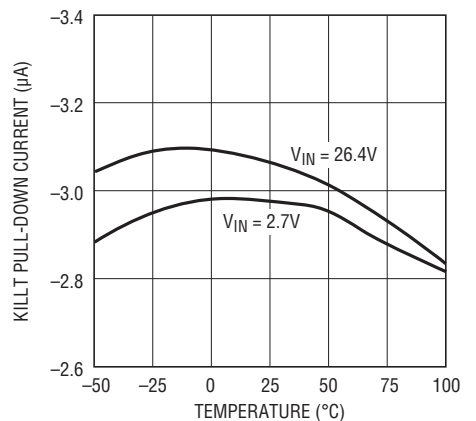

2951 G09

TYPICAL PERFORMANCE CHARACTERISTICS

PB Current vs PB Voltage

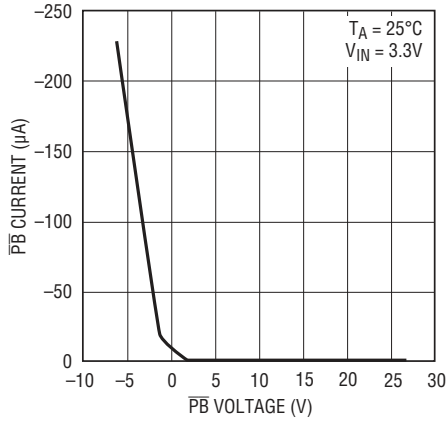

2951 G10

PB Voltage vs External PB Resistance to Ground

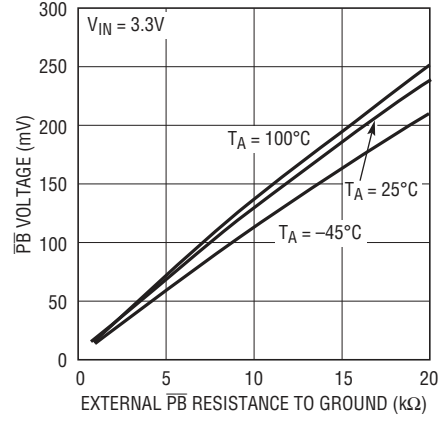

2951 G11

EN/EN VOL vs Current Load

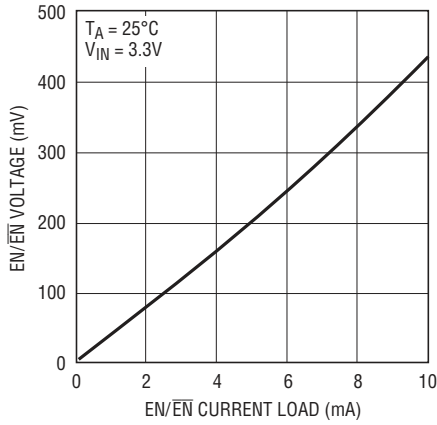

2951 G12

EN (LTC2951-1) Voltage vs VIN

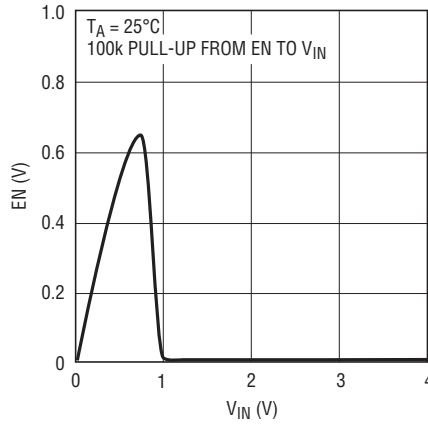

2951 G13

EN (LTC2951-2) Voltage vs VIN

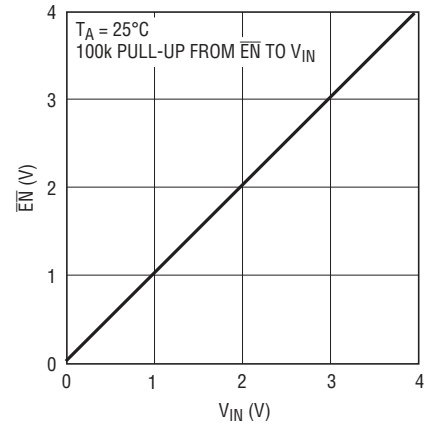

2951 G14

PIN FUNCTIONS (TSOT-23/DFN)

V_{IN} (Pin 1/Pin 4): Power Supply Input: 2.7V to 26.4V.

$\overline{\text{PB}}$ (Pin 2/Pin 3): Pushbutton Input. Connecting $\overline{\text{PB}}$ to ground through a momentary switch provides on/off control via the EN/ $\overline{\text{EN}}$ pin. An internal 100k pull-up resistor connects to an internal 1.9V bias voltage. The rugged $\overline{\text{PB}}$ input can be pulled up to 26.4V externally without consuming extra current.

KILLT (Pin 3/Pin 2): Additional, Adjustable $\overline{\text{KILL}}$ Turn-Off Delay Input ($t_{\text{KILL, OFF DELAY, ADDITIONAL}}$). A capacitor to ground provides additional delay time (beyond the internal default 128ms, $t_{\text{KILL, OFF DELAY}}$) from $\overline{\text{INT}}$ falling to the automatic release of the enable output. The $\overline{\text{KILL}}$ turn-off delay feature ensures the release of the enable pin under system fault conditions, such as the μP not responding to the LTC2951 interrupt signal ($\overline{\text{INT}}$ low).

GND (Pin 4/Pin 1): Device Ground.

$\overline{\text{INT}}$ (Pin 5/Pin 8): Open-Drain Interrupt Output. After a pushbutton turn-off event is detected ($t_{\text{DB, OFF}} + t_{\text{OFFT}}$), the LTC2951 interrupts the system (μP) by bringing the $\overline{\text{INT}}$ pin low. Once the system finishes its power-down and housekeeping tasks, it sets $\overline{\text{KILL}}$ low, which in turn releases the enable output. If at the end of the power-down timer period ($t_{\text{KILL, OFF DELAY}} + t_{\text{KILL, OFF DELAY, ADDITIONAL}}$) $\overline{\text{KILL}}$ is still high, the enable output is released immediately. $\overline{\text{INT}}$ may optionally be tied to $\overline{\text{KILL}}$ to release the enable output immediately after the turn-off event has been detected ($\overline{\text{INT}}$ low).

EN (LTC2951-1, Pin 6/Pin 7): Open-Drain Enable Output. This pin is intended to enable system power. EN goes high after a valid $\overline{\text{PB}}$ turn-on event ($t_{\text{DB, ON}}$). EN goes low if: a) $\overline{\text{KILL}}$ is not driven high within 512ms of the initial valid

$\overline{\text{PB}}$ power turn-on event, b) $\overline{\text{KILL}}$ is driven low during normal operation, or c) a second valid $\overline{\text{PB}}$ event (power turn-off) is detected. This pin can connect directly to a DC/DC converter shutdown pin that provides an internal pull-up. Otherwise, a pull-up resistor to an external supply is required. The operating range for this pin is 0V to 10V.

$\overline{\text{EN}}$ (LTC2951-2, Pin 6/Pin 7): Open-Drain Enable Output. This pin is intended to enable system power. $\overline{\text{EN}}$ is asserted low after a valid $\overline{\text{PB}}$ turn-on event ($t_{\text{DB, ON}}$). $\overline{\text{EN}}$ releases high if: a) $\overline{\text{KILL}}$ is not driven high within 512ms of the initial valid $\overline{\text{PB}}$ power turn-on event, b) $\overline{\text{KILL}}$ is driven low during normal operation, or c) a second valid $\overline{\text{PB}}$ event (power turn-off) is detected. This pin can connect directly to a DC/DC converter shutdown pin that provides an internal pull-up. Otherwise, a pull-up resistor to an external supply is required. The operating range of this pin is 0V to 10V.

OFFT (Pin 7/Pin 6): Additional Adjustable Turn-Off Time Input (t_{OFFT}). A capacitor to ground determines the additional time (beyond the internal default 32ms, $t_{\text{DB, OFF}}$) that the $\overline{\text{PB}}$ pin must be held low before initiating a power-down sequence ($\overline{\text{INT}}$ falling). Floating this pin results in a default turn-off debounce time of 32ms.

$\overline{\text{KILL}}$ (Pin 8/Pin 5): $\overline{\text{KILL}}$ Input. Forcing $\overline{\text{KILL}}$ low releases the enable output. During system turn-on, this pin is blanked by a 512ms internal timer ($t_{\text{KILL, ON BLANK}}$) to allow the system to pull $\overline{\text{KILL}}$ high. This pin has an accurate 0.6V threshold and can be used as a voltage monitor input. If unused, connect to a low voltage output supply (see Figure 6).

Exposed Pad (Pin 9): Exposed Pad may be left open or connected to device ground.

BLOCK DIAGRAM

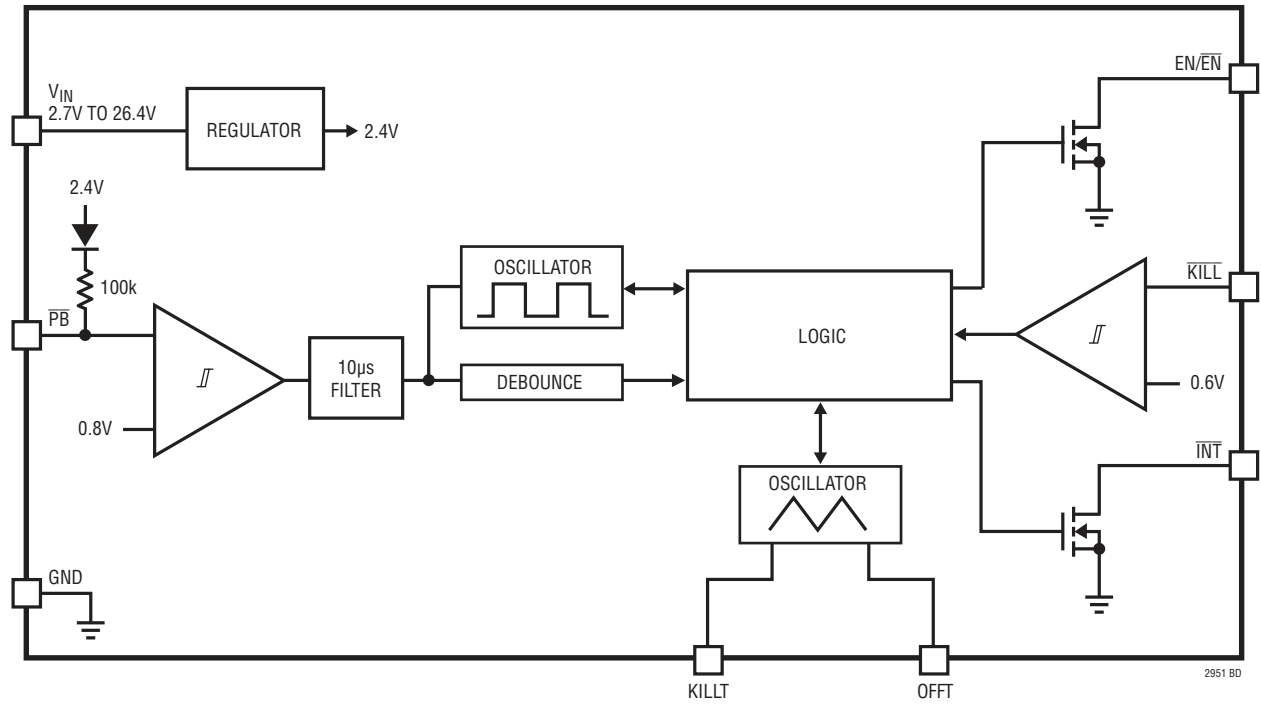

TIMING DIAGRAMS

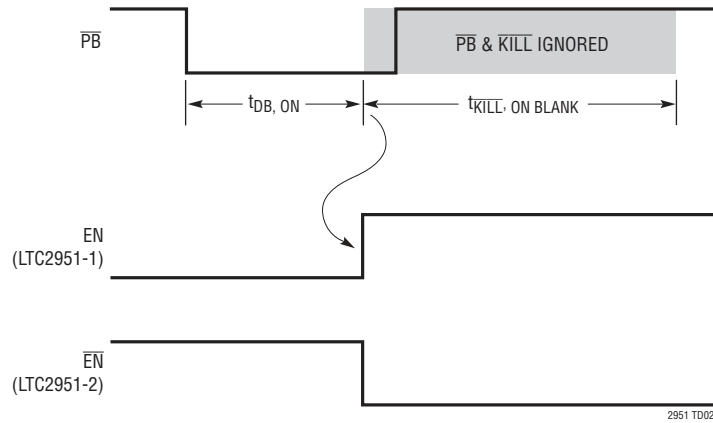
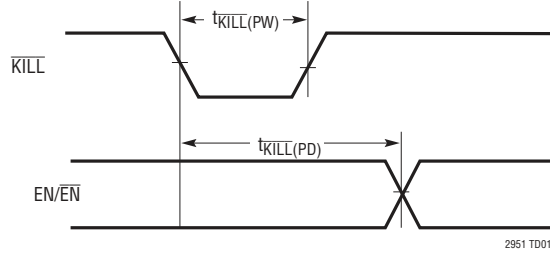

Power-On Timing

TIMING DIAGRAMS

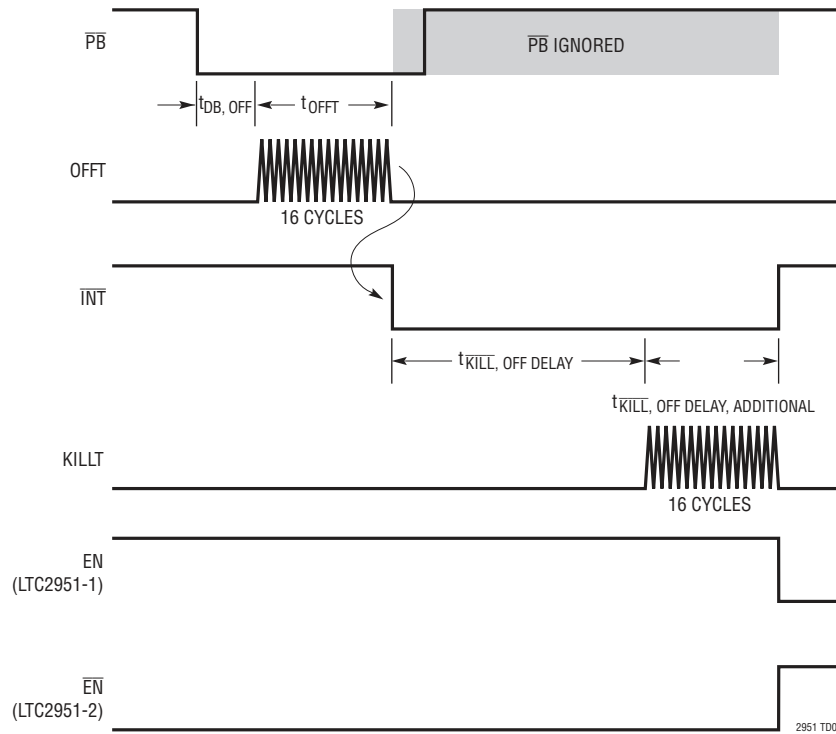

Power-Off Timing, $\overline{KILL} > 0.6V$

APPLICATIONS INFORMATION

Description

The LTC2951 is a low power (6 μ A), wide input voltage range (2.7V to 26.4V), pushbutton On/Off controller that can interface to a μ P and a power supply. The part incorporates all the flexible timing needed to debounce the pushbutton input ($\overline{\text{PB}}$). The LTC2951 also provides a simple interface ($\overline{\text{INT}}$ output, $\overline{\text{KILL}}$ input) to allow a system to power on and power off in a controlled manner. The wide input voltage range allows a system designer to operate from single cell to multi-cell battery stacks. Very low quiescent current makes the LTC2951 ideal for continuously monitoring the on/off pushbutton of a handheld device.

Turn-On

When power is first applied to the LTC2951, the part initializes the output pins. Any DC/DC converters connected to the $\overline{\text{EN}}/\overline{\text{EN}}$ pin will, therefore, be off. To assert the enable output, $\overline{\text{PB}}$ must be held low for a minimum of 128ms ($t_{\text{DB, ON}}$).

Once the enable output is asserted, any DC/DC converters connected to this pin are turned on. The $\overline{\text{KILL}}$ input from the μ P is ignored during the succeeding 512ms blanking time ($t_{\text{KILL, ON BLANK}}$). This blanking time represents the maximum time required to power up the DC/DC converter and the μ P. If $\overline{\text{KILL}}$ is not brought high during this 512ms time window, the enable output is released. The assumption is that 512ms is sufficient time for the system to power up.

Turn-Off

To initiate a power-off sequence, $\overline{\text{PB}}$ must be held low for a minimum of 32ms ($t_{\text{DB, OFF}}$). Additional turn-off debounce time may be added via an optional capacitor connected to the OFFT pin (t_{OFFT}). The following equation describes the additional time that $\overline{\text{PB}}$ must be held low to initiate a power-off sequence. C_{OFFT} is the OFFT external capacitor:

$$C_{\text{OFFT}} = 1.56\text{E-}4 [\mu\text{F/ms}] \cdot (t_{\text{OFFT}} - 1\text{ms})$$

Once $\overline{\text{PB}}$ has been validly pressed, $\overline{\text{INT}}$ is switched low. This alerts the μ P to perform its power-down and house-keeping tasks.

$\overline{\text{KILL}}$ Turn-Off Delay

The LTC2951 provides a failsafe feature that allows the user to turn off system power (via $\overline{\text{PB}}$) under system fault conditions. During a normal power-down sequence, the LTC2951 first interrupts the μ P by setting $\overline{\text{INT}}$ low. The μ P then performs power-down and housekeeping tasks and drives $\overline{\text{KILL}}$ low when done. The LTC2951 releases the enable output, thus turning off system power. The $\overline{\text{KILL}}$ turn-off timer starts when $\overline{\text{INT}}$ is driven low. If the μ P fails to respond during this timeout period, the enable output will automatically release. The default power-down timeout period is 128ms ($t_{\text{KILL, OFF DELAY}}$), which can be extended by placing an optional capacitor on the $\overline{\text{KILLT}}$ pin ($t_{\text{KILL, OFF DELAY, ADDITIONAL}}$). The following equation describes the additional power-down timeout period. C_{KILLT} is the $\overline{\text{KILLT}}$ external capacitor:

$$C_{\text{KILLT}} = 1.56\text{e-}4 [\mu\text{F/ms}] \cdot (t_{\text{KILL, OFF DELAY, ADDITIONAL}} - 1\text{ms})$$

Note that $\overline{\text{KILL}}$ can be driven low (thereby releasing the enable output) at any time after $t_{\text{KILL, ON BLANK}}$ period.

APPLICATIONS INFORMATION

Simplified Power-On/-Off Sequence

Figure 1 shows a simplified LTC2951-1 power-on and power-off sequence. A high to low transition on \overline{PB} (t_1) initiates the power-on sequence. This diagram does not show any bounce on \overline{PB} . In order to assert the enable output, the \overline{PB} pin must stay low continuously (\overline{PB} high resets timers) for 128ms (t_2-t_1). Once EN goes high (t_2), an internal 512ms blanking timer is started. This blanking timer is designed to give sufficient time for the DC/DC converter to reach its final voltage, and to allow the μP enough time to perform power-on tasks.

The \overline{KILL} pin must be pulled high within 512ms of the EN pin going high. Failure to do so results in the EN

pin going low 512ms after it went high. (EN = low, see Figure 2). Note that the LTC2951 does not sample \overline{KILL} and \overline{PB} until after the 512ms internal timer has expired. The reason \overline{PB} is ignored is to ensure that the system is not forced off while powering on. Once the 512ms timer expires (t_4), the release of the \overline{PB} pin is then debounced with an internal 32ms timer. The system has now properly powered on and the LTC2951 monitors \overline{PB} and \overline{KILL} (for a turnoff command) while consuming only 6 μA of supply current.

A high to low transition on \overline{PB} (t_5) initiates the power-off sequence. \overline{PB} must stay low continuously (\overline{PB} high resets timer) for a period controlled by the default 32ms

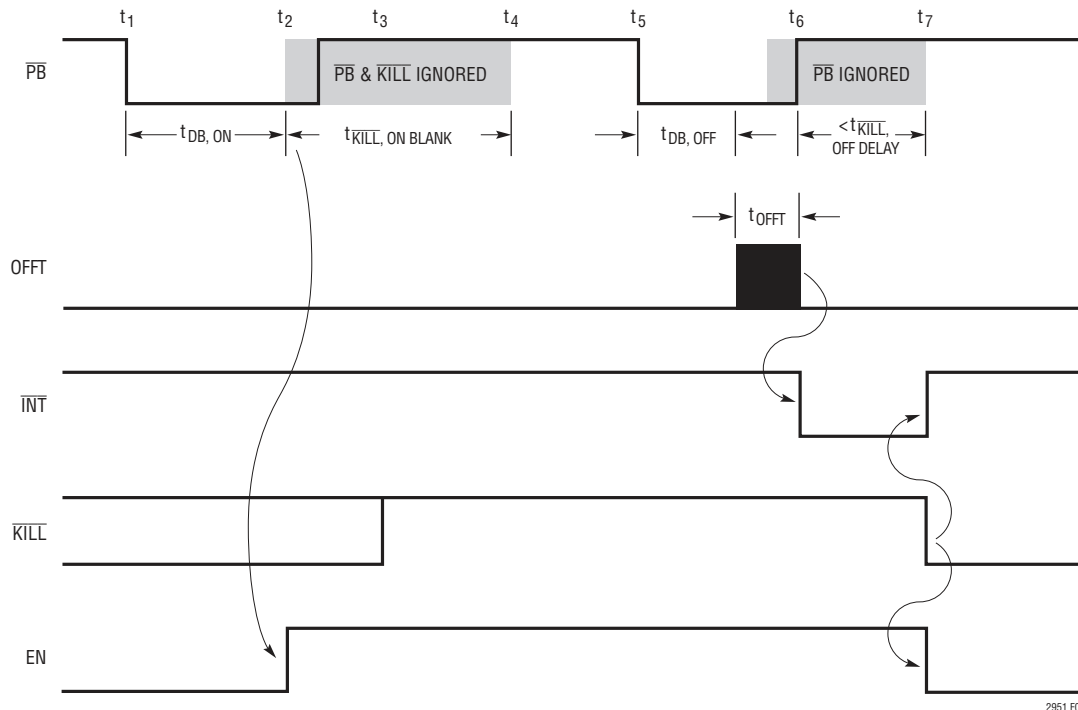

Figure 1. Simplified Power-On/-Off Sequence for LTC2951-1

APPLICATIONS INFORMATION

and the external OFFT capacitor (t_6-t_5). At the completion of the OFFT timing (t_6), an interrupt (\overline{INT}) is set, signifying that EN will be switched low after the \overline{KILL} turn-off ($t_{\overline{KILL}}$: OFF DELAY + $t_{\overline{KILL}}$: OFF DELAY, ADDITIONAL) timeout period. Once a system has finished performing its power-down operations, it can set \overline{KILL} low (t_7) and thus immediately set EN low, terminating the \overline{KILL} turn-off timer. The release of the \overline{PB} pin is then debounced with an internal 32ms timer.

The system is now in its reset state: where the LTC2951 is in low power mode (6 μ A). \overline{PB} is monitored for a high to low transition.

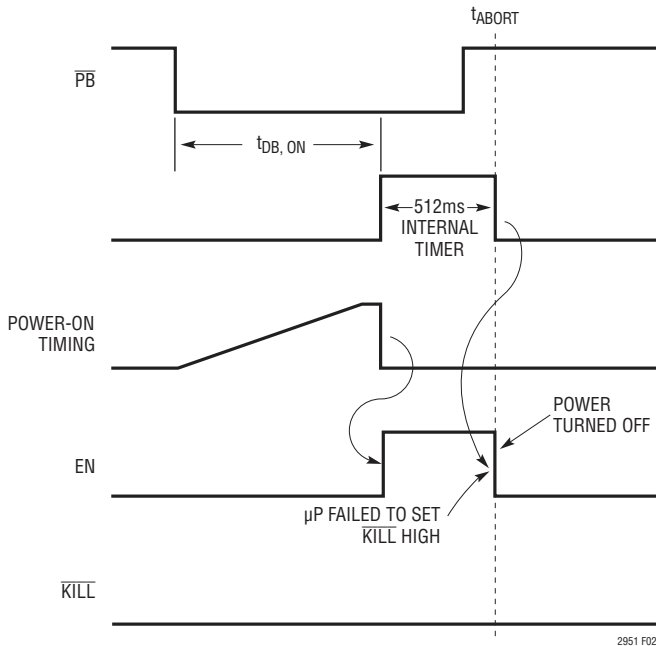

Figure 2. Aborted Power-On Sequence for LTC2951-1

Aborted Power-On Sequence

The power-on sequence is aborted when the \overline{KILL} remains low after the end of the 512ms blanking time. Figure 2 is a simplified version of an aborted power-on sequence. At time t_{ABORT} , since \overline{KILL} is still low, EN pulls low (thus turning off the DC/DC converter).

μP Turns Off Power During Normal Operation

Once the system has powered on and is operating normally, the μ P can turn off power by setting \overline{KILL} low, as shown in Figure 3. At time $t_{\overline{KILL}}$, \overline{KILL} is set low by the μ P. This immediately pulls EN low, thus turning off the DC/DC converter.

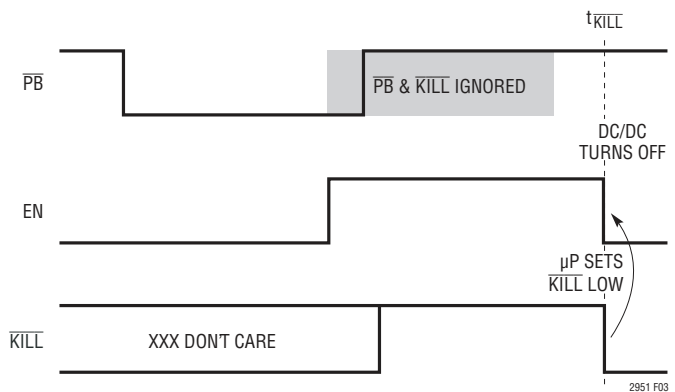

Figure 3. μ P Turns Off Power (LTC2951-1)

APPLICATIONS INFORMATION

DC/DC Turn-Off Blanking

When the DC/DC converter is turned off, it can take a significant amount of time for its output to decay to ground. It is desirable to wait until the output of the DC/DC converter is near ground before allowing the user (via $\overline{\text{PB}}$) to restart the converter. This condition guarantees that the μP is always powered down completely before it is restarted.

Figure 4 shows the μP turning power off. After a low on $\overline{\text{KILL}}$ releases enable, $\overline{\text{PB}}$ is ignored during the internal 256ms timer period. This is shown as $t_{\text{EN}/\overline{\text{EN}}, \text{LOCKOUT}}$ in Figure 4.

LTC2951-1, LTC2951-2 Versions

The LTC2951-1 (high true EN) and LTC2951-2 (low true $\overline{\text{EN}}$) differ only by the polarity of the EN/ $\overline{\text{EN}}$ pin. Both versions allow the user to extend the amount of time that the $\overline{\text{PB}}$ must be held low in order to begin a valid power-off sequence. An external capacitor placed on the OFFT pin adds additional time to the turn-off debounce time. If no capacitor is placed on the OFFT pin, then the turn-off debounce time is given by an internally fixed 32ms timer.

Both versions of the LTC2951 provide extendable $\overline{\text{KILL}}$ turn-off timer, $t_{\overline{\text{KILL}}, \text{OFF DELAY, ADDITIONAL}}$, by connecting an optional external capacitor on the KILLT pin. The default $\overline{\text{KILL}}$ turn-off delay time is 128ms, $t_{\overline{\text{KILL}}, \text{OFF DELAY}}$.

High Voltage Pins

The V_{IN} and $\overline{\text{PB}}$ pins can operate at voltages up to 26.4V. $\overline{\text{PB}}$ can, additionally, operate below ground (-6V) without latching up the device. $\overline{\text{PB}}$ has an ESD HBM rating of $\pm 10\text{kV}$. If the pushbutton switch connected to $\overline{\text{PB}}$ exhibits high leakage current, then an external pull-up resistor to V_{IN} is recommended. Furthermore, if the pushbutton switch is physically located far from the LTC2951 $\overline{\text{PB}}$ pin, parasitic capacitances may couple onto the high impedance $\overline{\text{PB}}$ input. Additionally, parasitic series inductance may cause unpredictable ringing at the $\overline{\text{PB}}$ pin. Placing a 5k resistor from the $\overline{\text{PB}}$ pin to the pushbutton switch would mitigate parasitic inductance problems. Placing a $0.1\mu\text{F}$ capacitor on the $\overline{\text{PB}}$ pin would lessen the impact of parasitic capacitive coupling.

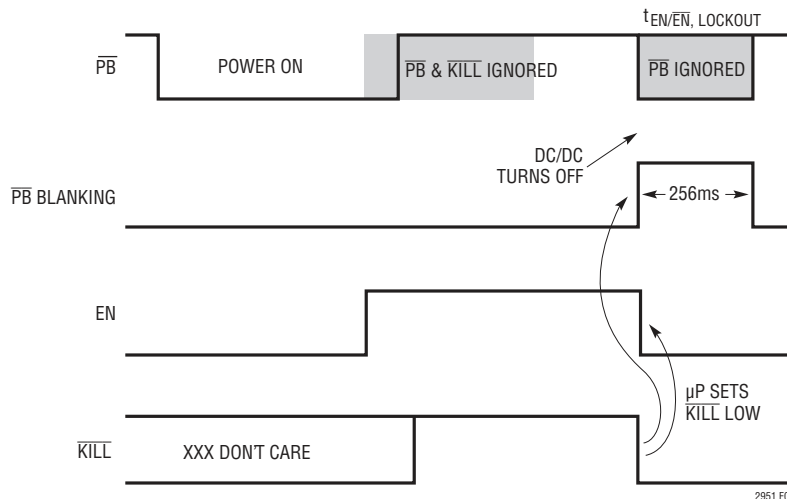

Figure 4. DC/DC Turn-Off Blanking (LTC2951-1)

TYPICAL APPLICATIONS

Voltage Monitoring with $\overline{\text{KILL}}$ Input

The $\overline{\text{KILL}}$ pin can be used as a voltage monitor. Figure 5 shows an application where the $\overline{\text{KILL}}$ pin has a dual function. It is driven by a low leakage open-drain output of the μP . It is also connected to a resistor divider that monitors battery voltage (V_{IN}). When the battery voltage falls below the set value, the voltage at the $\overline{\text{KILL}}$ pin falls below 0.6V and the EN pin is quickly pulled low. Note that the resistor values should be as large as possible, but small enough to keep leakage currents from tripping the 0.6V $\overline{\text{KILL}}$ comparator.

The DC/DC converter shown has an internal pull-up current on its $\overline{\text{SHDN}}$ pin. A pull-up resistor on EN is thus not needed.

Operation without μP

Figure 6 shows how to connect the $\overline{\text{KILL}}$ pin when there is no circuitry available to drive it. The minimum pulse width detected is 30 μs . If there are glitches on the resistor pull-up voltage that are wider than 30 μs and transition below 0.6V, then an appropriate bypass capacitor should be connected to the $\overline{\text{KILL}}$ pin.

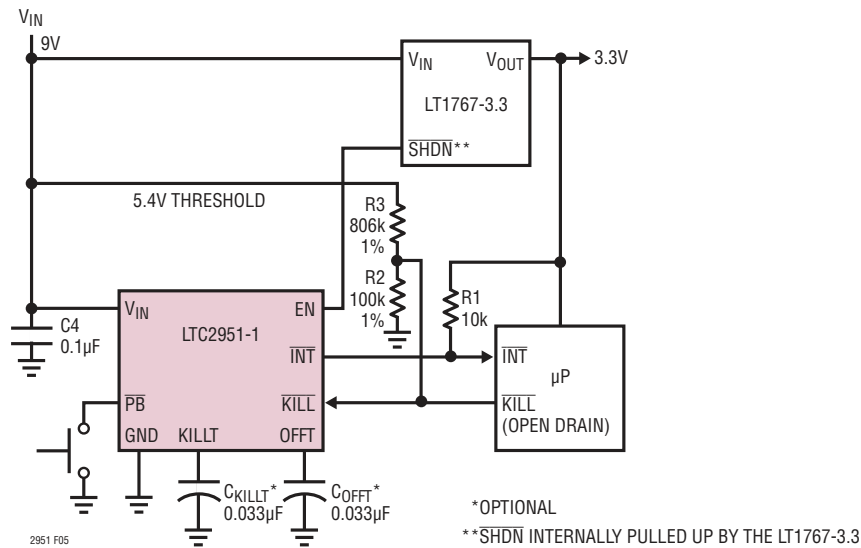

Figure 5. Input Voltage Monitoring with $\overline{\text{KILL}}$ Input

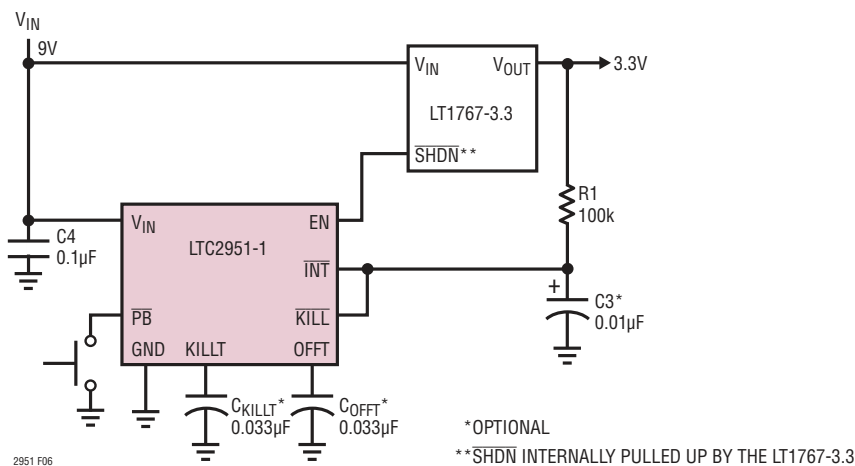

Figure 6. No μP Application

TYPICAL APPLICATIONS

PowerPath™ Switching

The $\overline{\text{EN}}$ open-drain output of the LTC2951-2 is designed to switch on/off an external power PFET. This allows a user to connect/disconnect a power supply (or battery) to its load by toggling the $\overline{\text{PB}}$ pin. Figure 7 shows the LTC2951-2 controlling a two cell Li-Ion battery application. The INT and KILL pins are connected to the output of the PFET through a resistor divider. The KILL pin serves as a voltage monitor. When V_{OUT} drops below 6V, the $\overline{\text{EN}}$ pin is open-circuited 30 μs later.

$\overline{\text{PB}}$ Pin in a Noisy Environment

The rugged $\overline{\text{PB}}$ pin is designed to operate in noisy environments. Transients below ground ($> -6\text{V}$) and above V_{IN} ($< 33\text{V}$) will not damage the rugged $\overline{\text{PB}}$ pin. Additionally, the $\overline{\text{PB}}$ pin can withstand ESD HBM strikes up to $\pm 10\text{kV}$.

In order to keep external noise from coupling inside the LTC2951, place an RC network close to the $\overline{\text{PB}}$ pin. A 5k resistor and a 0.1 μF capacitor should suffice for most noisy applications (see Figure 8).

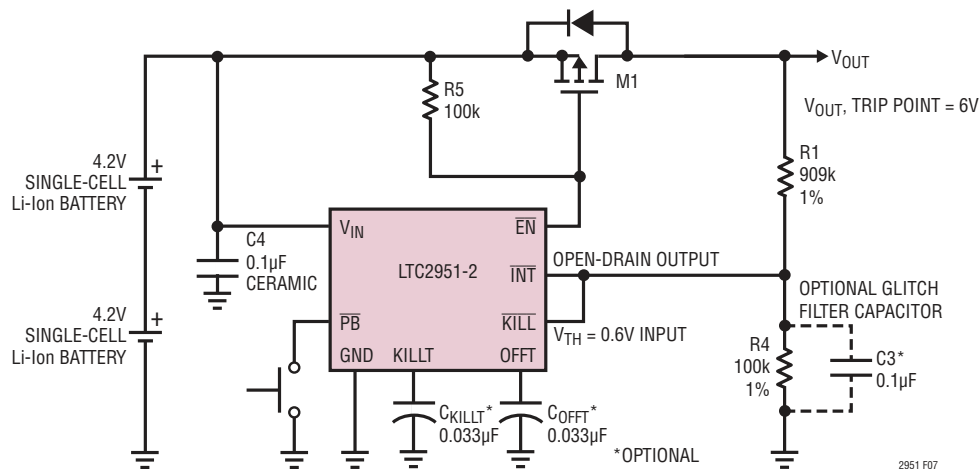

Figure 7. PowerPath Control with 6V Undervoltage Detect

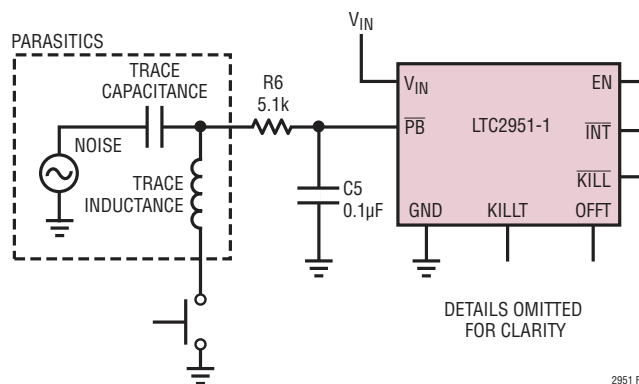

Figure 8. Filtering for Noisy $\overline{\text{PB}}$ Traces

TYPICAL APPLICATIONS

External Pull-Up Resistor on \overline{PB}

An internal pull-up resistor on the \overline{PB} pin makes an external pull-up resistor unnecessary. Leakage current on the \overline{PB} board trace, however, will affect the open circuit voltage on the \overline{PB} pin. If the leakage is too large ($>2\mu\text{A}$), the \overline{PB} voltage may fall close to the threshold window. To mitigate the effect of the board leakage, a 10k resistor to V_{IN} is recommended (see Figure 9).

Reverse-Battery Protection

To protect the LTC2951 from a reverse-battery connection, place a 1k resistor (R8) in series with the V_{IN} pin (see Figure 10).

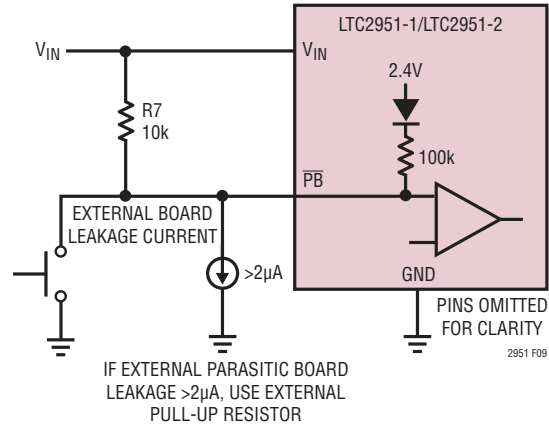
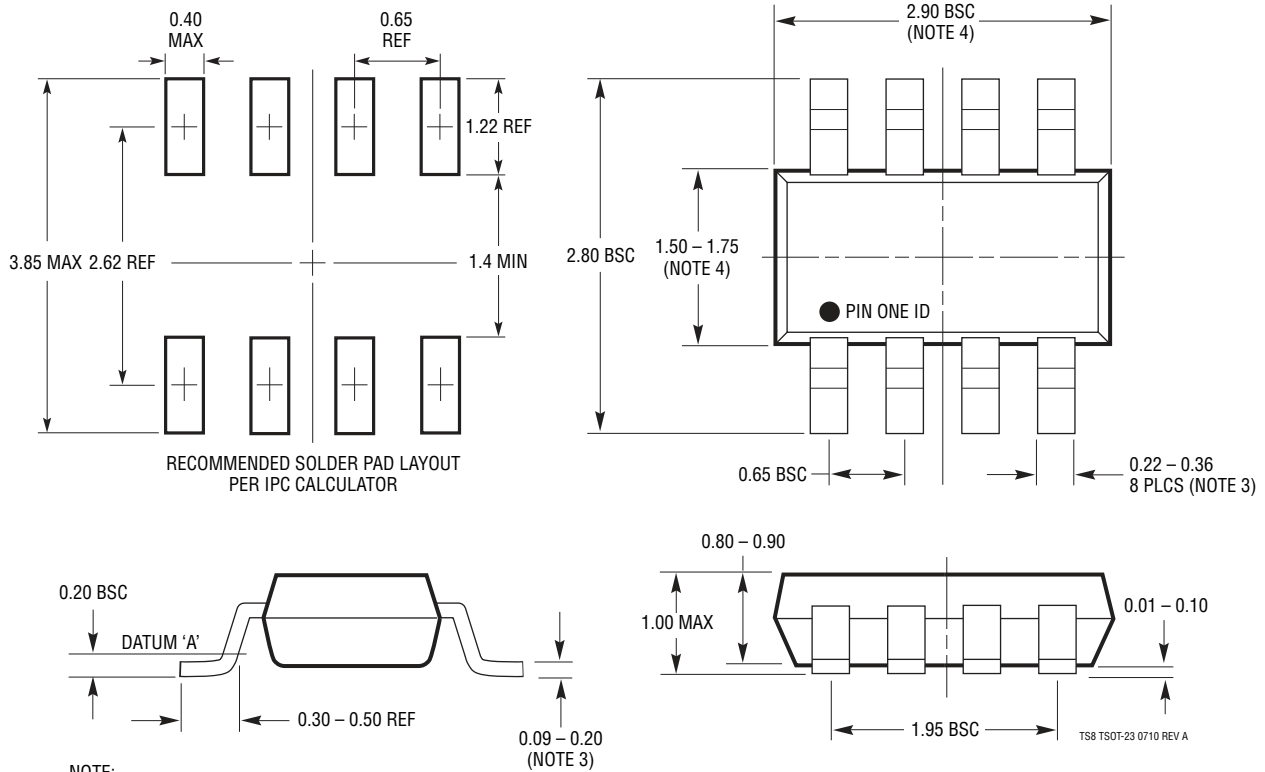

Figure 9. External Pull-Up Resistor on \overline{PB} Pin

PACKAGE DESCRIPTION

TS8 Package
8-Lead Plastic TSOT-23
 (Reference LTC DWG # 05-08-1637)



- NOTE:
1. DIMENSIONS ARE IN MILLIMETERS
 2. DRAWING NOT TO SCALE
 3. DIMENSIONS ARE INCLUSIVE OF PLATING
 4. DIMENSIONS ARE EXCLUSIVE OF MOLD FLASH AND METAL BURR
 5. MOLD FLASH SHALL NOT EXCEED 0.254mm
 6. JEDEC PACKAGE REFERENCE IS MO-193

TS8 TSOT-23 0710 REV A

REVISION HISTORY (Revision history begins at Rev B)

REV	DATE	DESCRIPTION	PAGE NUMBER
B	01/11	Revised Features and Typical Application	1
		Updated Pin Configuration	2
		Revised Electrical Characteristics section	3
		Revised Pin Functions section	6
		Revised Block Diagram	7
		Minor edit to Figure 1	11
		Added C3 to Figure 6	14
		Updated Figure 8	15
		Updated Related Parts	20

LTC2951-1/LTC2951-2

TYPICAL APPLICATION

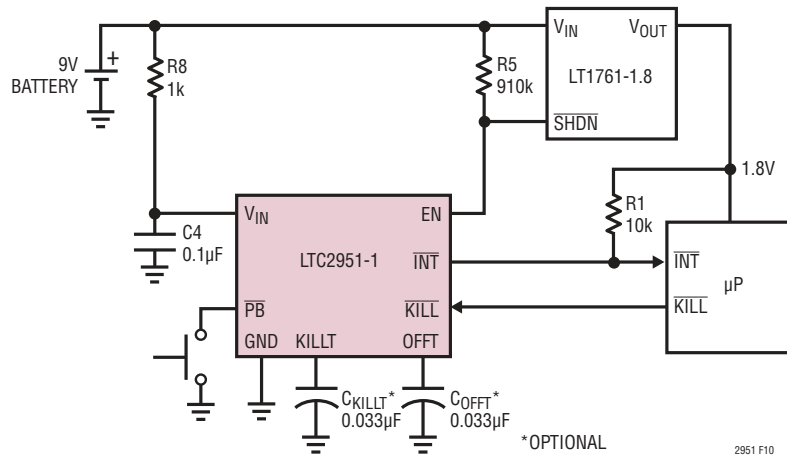

Figure 10. Reverse-Battery Protection Using R8

RELATED PARTS

PART NUMBER	DESCRIPTION	COMMENTS
LTC2900	Programmable Quad Supply Monitor	Adjustable $\overline{\text{RESET}}$, 10-Lead MSOP and 3mm × 3mm DFN Packages
LTC2904/LTC905	Pin-Programmable Dual Supply Monitors	Adjustable $\overline{\text{RESET}}$ and Tolerance, 8-Lead SOT-23 and 3mm × 2mm DFN Packages
LTC2950	Micropower Pushbutton On/Off Controller	High Voltage Pushbutton Controller with μP Interface and Adjustable On-Time
LTC2953	Pushbutton On/Off Controller with Voltage Monitoring	High Voltage Pushbutton Controller with 200ms Voltage Reset Monitor
LTC2954	Pushbutton On/Off Controller with MP Interrupt	Allows Controlled Software System Shutdown
LTC2952	Pushbutton PowerPath Controller with Supervisor	Automatic Low Loss Switchover Between DC Sources
LTC4411	2.6A Low Loss Ideal Diode in ThinSOT	No External MOSFET, Automatic Switching Between DC Sources
LTC4412HV	PowerPath Controller in ThinSOT	Efficient Diode-ORing, Automatic Switching Between DC Sources, 3V to 36V
LTC4055	USB Power Controller and Li-Ion Charger	Automatic Switchover, Charges 1-Cell Li-Ion Batteries