

FEATURES

RF bandwidth:

25 MHz to 3000 MHz

3.3 V supply
Maximum phase detector rate: 100 MHz
Ultralow phase noise

–110 dBc/Hz in band, typical

Fractional figure of merit (FOM): –226 dBc/Hz
24-bit step size, resolution 3 Hz typical
Exact frequency mode with 0 Hz frequency error
Fast frequency hopping
40-lead 6 mm × 6 mm SMT package: 36 mm²

APPLICATIONS

Cellular infrastructure

Microwave radio

WiMax, WiFi

Communications test equipment

CATV equipment

DDS replacement

Military

Tunable reference source for spurious-free performance

GENERAL DESCRIPTION

The [HMC832](#) is a 3.3 V, high performance, wideband, fractional-N, phase-locked loop (PLL) that features an integrated voltage controlled oscillator (VCO) with a fundamental frequency of 1500 MHz to 3000 MHz, and an integrated VCO output divider (divide by 1/2/4/6/...60/62), that enables the [HMC832](#) to generate continuous frequencies from 25 MHz to 3000 MHz. The integrated phase detector (PD) and delta-sigma (Δ - Σ) modulator, capable of operating at up to 100 MHz, permit wider loop bandwidths and faster frequency tuning with excellent spectral performance.

Industry leading phase noise and spurious performance, across all frequencies, enable the [HMC832](#) to minimize blocker effects, and to improve receiver sensitivity and transmitter spectral purity. A low noise floor (–160 dBc/Hz) eliminates any contribution to modulator/mixer noise floor in transmitter applications.

FUNCTIONAL BLOCK DIAGRAM

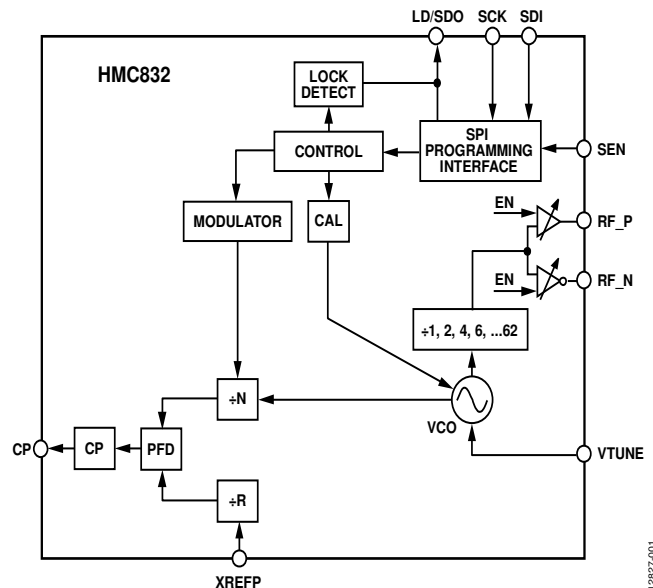

Figure 1.

The [HMC832](#) is footprint-compatible to the market leading [HMC830](#) PLL with integrated VCO. It features 3.3 V supply and an innovative programmable performance technology that enables the [HMC832](#) to tailor current consumption and corresponding noise floor performance to individual applications by selecting either a low current consumption mode or a high performance mode for an improved noise floor performance.

Additional features of the [HMC832](#) include 12 dB of RF output gain control in 1 dB steps; output mute function to automatically mute the output during frequency changes when the device is not locked; selectable output return loss; programmable differential or single-ended outputs, with the ability to select either output in single-ended mode; and a Δ - Σ modulator exact frequency mode that enables users to generate output frequencies with 0 Hz frequency error.

TABLE OF CONTENTS

Features	1	PLL Register Map	36
Applications	1	ID, Read Address, and RST Registers	36
Functional Block Diagram	1	Reference Divider, Integer, and Fractional Frequency Registers.....	36
General Description	1	VCO SPI Register	37
Revision History	2	Delta-Sigma Configuration.....	37
Specifications.....	3	Lock Detect Register	38
Timing Specifications	5	Analog Enable (EN) Register.....	38
Absolute Maximum Ratings.....	6	Charge Pump Register	39
Recommended Operating Conditions	6	Autocalibration Register.....	39
ESD Caution.....	6	Phase Detector (PD) Register	40
Pin Configuration and Function Descriptions.....	7	Exact Frequency Mode Register.....	40
Typical Performance Characteristics	8	General-Purpose, Serial Port Interface, and Reference Divider (GPO_SPI_RDIV) Register	41
Theory of Operation	14	VCO Tune Register	42
PLL Subsystem Overview.....	14	SAR Register	42
VCO Subsystem Overview.....	14	General-Purpose 2 Register	42
SPI (Serial Port Interface) Configuration of PLL and VCO Subsystems.....	14	Built-In Self Test Register	42
VCO Subsystem.....	16	VCO Subsystem Register Map.....	43
PLL Subsystem	20	VCO Enable Register	43
Soft Reset and Power-On Reset.....	28	VCO Output Divider Register.....	44
Power-Down Mode	29	VCO Configuration Register	44
General-Purpose Output (GPO) Pin.....	29	VCO Calibration/Bias, CF Calibration, and MSB Calibration Registers.....	45
Chip Identification	29	VCO Output Power Control.....	45
Serial Port	29	Evaluation Printed Circuit Board (PCB).....	46
Applications Information	33	Changing Evaluation Board Reference Frequency and CP Current Configuration	46
Power Supply.....	34	Evaluation Kit Contents	46
Programmable Performance Technology.....	34	Outline Dimensions	47
Loop Filter and Frequency Changes.....	34	Ordering Guide	48
RF Programmable Output Return Loss.....	35		
Mute Mode	35		

REVISION HISTORY

11/14—Rev. 0 to Rev. A

This Hittite Microwave Products data sheet has been reformatted to meet the styles and standards of Analog Devices, Inc.

Updated Format	Universal
Moved Endnotes from Typical Performance Characteristics Section to the Applications Information Section	34
Changes to Ordering Guide	48

SPECIFICATIONS

VPPCP, VDDL, VCC1, VCC2 = 3.3 V; RVDD, AVDD, DVDD, VCCPD, VCCH, VCCPS = 3.3 V minimum and maximum specified across the temperature range of -40°C to $+85^{\circ}\text{C}$.

Table 1.

Parameter	Test Conditions/Comments	Min	Typ	Max	Unit
RF OUTPUT CHARACTERISTICS					
Output Frequency		25		3000	MHz
VCO Frequency at PLL Input		1500		3000	MHz
RF Output Frequency at f_{VCO}		1500		3000	MHz
OUTPUT POWER					
RF Output Power at Fundamental Frequency	2000 MHz across all frequencies (see Figure 25) Maximum gain setting: VCO_REG 0x07[3:0] = 11d single-ended Gain Setting 6: VCO_REG 0x07[3:0] = 6d differential		7		dBm
Output Power Control Range	1 dB steps		2 12		dBm dB
HARMONICS FOR FUNDAMENTAL MODE					
fo Mode at 2 GHz	$2^{\text{nd}}/3^{\text{rd}}/4^{\text{th}}$		-20/-29/-45		dBc
fo/2 Mode at 2 GHz/2 = 1 GHz	$2^{\text{nd}}/3^{\text{rd}}/4^{\text{th}}$		-26/-10/-34		dBc
fo/30 Mode at 3 GHz/30 = 100 MHz	$2^{\text{nd}}/3^{\text{rd}}/4^{\text{th}}$		-33/-10/-40		dBc
fo/62 Mode at 1550 MHz/62 = 25 MHz	$2^{\text{nd}}/3^{\text{rd}}/4^{\text{th}}$		-40/-6/-43		dBc
VCO OUTPUT DIVIDER					
VCO RF Divider Range	1, 2, 4, 6, 8, ... 62	1		62	
PLL RF DIVIDER CHARACTERISTICS					
19-Bit N-Divider Range (Integer)	Maximum = $2^{19} - 1$	16		524,287	
19-Bit N-Divider Range (Fractional)	Fractional nominal divide ratio varies (± 4) dynamically maximum	20		524,283	
REFERENCE (XREFP PIN) INPUT CHARACTERISTICS					
Maximum XREFP Input Frequency				350	MHz
XREFP Input Level	AC-coupled ¹	-6		+12	dBm
XREFP Input Capacitance				5	pF
14-Bit R-Divider Range		1		16,383	
PHASE DETECTOR (PD)²					
PD Frequency Fractional Mode ³		DC		100	MHz
PD Frequency Integer Mode		DC		100	MHz
CHARGE PUMP					
Output Current		0.02		2.54	mA
Charge Pump Gain Step Size			20		μA
PD/Charge Pump SSB Phase Noise	50 MHz reference, input referred				
1 kHz			-143		dBc/Hz
10 kHz	Add 2 dB for fractional mode		-150		dBc/Hz
100 kHz	Add 3 dB for fractional mode		-152		dBc/Hz
LOGIC INPUTS					
V_{SW}		40	50	60	% DVDD
LOGIC OUTPUTS					
Output High Voltage (VOH)			DVDD		V
Output Low Voltage (VOL)			0		V
Output Impedance		100		200	Ω
Maximum Load Current				1.5	mA
POWER SUPPLY VOLTAGES					
3.3 V Supplies	AVDD, VCCH, VCCPS, VCCPD, RVDD, DVDD, VPPCP, VDDL, VCC1, VCC2	3.1	3.3	3.5	V

Parameter	Test Conditions/Comments	Min	Typ	Max	Unit
POWER SUPPLY CURRENTS					
High Performance Mode 2500 MHz, Gain 11	VCO_REG 0x03[1:0] = 3d ⁴ Gain 11 (VCO_REG 0x07[3:0] = 11d) single-ended output (VCO_REG 0x03[3:2] = 2d)		219		mA
800 MHz, Gain 11 2500 MHz, Gain 6	Single-ended output Gain 6 (VCO_REG 0x07[3:0] = 6d) differential output (VCO_REG 0x03[3:2] = 3d)		230 226		mA mA
800 MHz, Gain 6 2500 MHz, Gain 1	Differential output Gain 1 (VCO_REG 0x07[3:0] = 1d) differential output (VCO_REG 0x03[3:2] = 3d)		237 210		mA mA
800 MHz, Gain 1 Low Current Mode 2500 MHz, Gain 6	Differential output VCO_REG 0x03[1:0] = 1d ⁴ Gain 6 (VCO_REG 0x07[3:0] = 6d), differential output (VCO_REG 0x03[3:2] = 3d)		221 195		mA mA
800 MHz, Gain 6 2500 MHz, Gain 1	Differential output Gain 1 (VCO_REG 0x07[3:0] = 1d), differential output (VCO_REG 0x03[3:2] = 3d)		205 180		mA mA
800 MHz, Gain 1 Power-Down Crystal Off	Differential output Register 0x01 = 0, crystal not clocked		192 10		mA μA
Crystal On, 100 MHz	Register 0x01 = 0, crystal clocked 100 MHz		5		mA
POWER-ON RESET					
Typical Reset Voltage on DVDD			700		mV
Minimum DVDD Voltage for No Reset		1.5			V
Power-On Reset Delay			250		μs
VCO OPEN-LOOP PHASE NOISE					
fo @ 2 GHz ⁵					
10 kHz Offset			-88		dBc/Hz
100 kHz Offset			-116		dBc/Hz
1 MHz Offset			-139		dBc/Hz
10 MHz Offset			-157		dBc/Hz
100 MHz Offset			-162		dBc/Hz
fo @ 2 GHz/2 = 1 GHz ⁵					
10 kHz Offset			-93		dBc/Hz
100 kHz Offset			-122		dBc/Hz
1 MHz Offset			-145		dBc/Hz
10 MHz Offset			-159		dBc/Hz
100 MHz Offset			-162		dBc/Hz
fo @ 3 GHz/30 = 100 MHz ⁵					
10 kHz Offset			-110		dBc/Hz
100 kHz Offset			-139		dBc/Hz
1 MHz Offset			-160		dBc/Hz
10 MHz Offset			-163		dBc/Hz
100 MHz Offset			-163		dBc/Hz
FIGURE OF MERIT (FOM)					
Floor Integer Mode (Figure 24)	Normalized to 1 Hz		-229		dBc/Hz
Floor Fractional Mode (Figure 24)	Normalized to 1 Hz		-226		dBc/Hz
Flicker (Both Modes) (Figure 24)	Normalized to 1 Hz		-268		dBc/Hz

Parameter	Test Conditions/Comments	Min	Typ	Max	Unit
VCO CHARACTERISTICS					
VCO Tuning Sensitivity					
2800 MHz	Measured with 1.5 V on VTUNE; see Figure 29		24.6		MHz/V
2400 MHz	Measured with 1.5 V on VTUNE; see Figure 29		25.8		MHz/V
2000 MHz	Measured with 1.5 V on VTUNE; see Figure 29		25.2		MHz/V
1600 MHz	Measured with 1.5 V on VTUNE; see Figure 29		24.3		MHz/V
VCO Supply Pushing	Measured with 1.5 V on VTUNE		2.8		MHz/V

¹ Measured with 100 Ω external termination. See Reference Input Stage section for more details.

² Slew rate of ≥ 0.5 ns/V is recommended, see Reference Input Stage section for more details. Frequency is guaranteed across process voltage and temperature from -40°C to $+85^{\circ}\text{C}$.

³ This maximum PD frequency can only be achieved if the minimum N value is respected. For example, in the case of fractional mode, the maximum PD frequency = $f_{\text{vco}}/20$ or 100 MHz, whichever is less.

⁴ For detailed current consumption information, refer to Figure 33 and Figure 36.

⁵ Gain setting = 6 (VCO_REG 0x07[3:0] = 6d) in high performance mode (VCO_REG 0x03[1:0] = 3d).

TIMING SPECIFICATIONS

SPI Write Timing Characteristics

AVDD = DVDD = 3 V, AGND = DGND = 0 V.

Table 2. SPI Write Timing Characteristics, See Figure 47

Parameter	Test Conditions/Comments	Min	Typ	Max	Unit
t ₁	SDI setup time to SCLK rising edge	3			ns
t ₂	SCLK rising edge to SDI hold time	3			ns
t ₃	SEN low duration	10			ns
t ₄	SEN high duration	10			ns
t ₅	SCLK 32 nd rising edge to SEN rising edge	10			ns
t ₆	Recovery time	20			ns
	Maximum serial port clock speed		50		MHz

Table 3. SPI Read Timing Characteristics, See Figure 48

Parameter	Test Conditions/Comments	Min	Typ	Max	Unit
t ₁	SDI setup time to SCK rising edge	3			ns
t ₂	SCK rising edge to SDI hold time	3			ns
t ₃	SEN low duration	10			ns
t ₄	SEN high duration	10			ns
t ₅	SCK rising edge to SDO time		8.2 ns + 0.2 ns/pF		ns
t ₆	Recovery time	10			ns
t ₇	SCK 32 nd rising edge to SEN rising edge	10			ns

ABSOLUTE MAXIMUM RATINGS

Table 4. Absolute Maximum Ratings

Parameter	Rating
AVDD, RVDD, DVDD, VCCPD, VCCHF, VCCPS VPPCP, VDDL, VCC1	–0.3 V to +3.6 V
VCC2	–0.3 V to +3.6 V
Operating Temperature	–40°C to +85°C
Storage Temperature	–65°C to +150°C
Maximum Junction Temperature	150°C
Thermal Resistance (θ_{JC}) (Junction to Case (Ground Paddle))	9°C/W
Reflow Soldering	
Peak Temperature	260°C
Time at Peak Temperature	40 sec
ESD Sensitivity (HBM)	Class 1B

Stresses at or above those listed under Absolute Maximum Ratings may cause permanent damage to the product. This is a stress rating only; functional operation of the product at these or any other conditions above those indicated in the operational section of this specification is not implied. Operation beyond the maximum operating conditions for extended periods may affect product reliability.

RECOMMENDED OPERATING CONDITIONS

Table 5. Recommended Operating Conditions

Parameter	Min	Typ	Max	Units
Temperature				
Junction Temperature ¹			125	°C
Ambient Temperature	–40		+85	°C
Supply Voltage				
AVDD, RVDD, DVDD, VCCPD, VCCHF, VCCPS, VPPCP, VDDL, VCC1, VCC2	3.1	3.3	3.5	V

¹ Layout design guidelines set out in [Qualification Test Report](#) are strongly recommended.

ESD CAUTION



ESD (electrostatic discharge) sensitive device. Charged devices and circuit boards can discharge without detection. Although this product features patented or proprietary protection circuitry, damage may occur on devices subjected to high energy ESD. Therefore, proper ESD precautions should be taken to avoid performance degradation or loss of functionality.

PIN CONFIGURATION AND FUNCTION DESCRIPTIONS

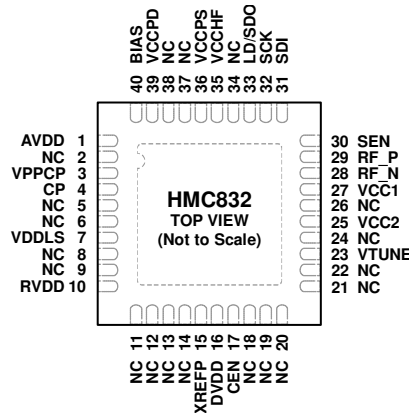

- NOTES**
 1. NC = NO CONNECT. DO NOT CONNECT TO THIS PIN.
 2. THE EXPOSED GROUND PAD MUST BE CONNECTED TO RF/DC GROUND.

12827-002

Figure 2. Pin Configuration

Table 6. Pin Function Descriptions

Pin No.	Mnemonic	Description
1	AVDD	DC Power Supply for Analog Circuitry.
2, 5, 6, 8, 9, 11 to 14, 18 to 22, 24, 26, 34, 37, 38	NC	No Connect. These pins are not connected internally; however, it is recommended to connect these pins to RF/dc ground externally.
3	VPPCP	Power Supply for Charge Pump Analog Section.
4	CP	Charge Pump Output.
7	VDDL5	Power Supply for the Charge Pump Digital Section.
10	RVDD	Reference Supply.
15	XREFP	Reference Oscillator Input.
16	DVDD	DC Power Supply for Digital (CMOS) Circuitry.
17	CEN	PLL Subsystem Enable. Note that there is no effect on the VCO subsystem. Connect to logic high for normal operation.
23	VTUNE	VCO Varactor. Tuning port input.
25	VCC2	VCO Analog Supply 2.
27	VCC1	VCO Analog Supply 1.
28	RF_N	RF Negative Output.
29	RF_P	RF Positive Output.
30	SEN	PLL Serial Port Enable (CMOS) Logic Input.
31	SDI	PLL Serial Port Data (CMOS) Logic Input.
32	SCK	PLL Serial Port Clock (CMOS) Logic Input.
33	LD/SDO	Lock Detect, or Serial Data, or General-Purpose (CMOS) Logic Output (GPO).
35	VCCHF	DC Power Supply for Analog Circuitry.
36	VCCPS	DC Power Supply for Analog Prescaler.
39	VCCPD	DC Power Supply for Phase Detector.
40	BIAS	External Bypass Decoupling for Precision Bias Circuits. Note: 1.920 V ± 20 mV reference voltage (BIAS) is generated internally and cannot drive an external load. It must be measured with a 10 GΩ meter, such as the Agilent 34410A; a normal 10 MΩ DVM reads erroneously.
	EP	Exposed Pad. The exposed pad must be connected to RF/dc ground.

TYPICAL PERFORMANCE CHARACTERISTICS

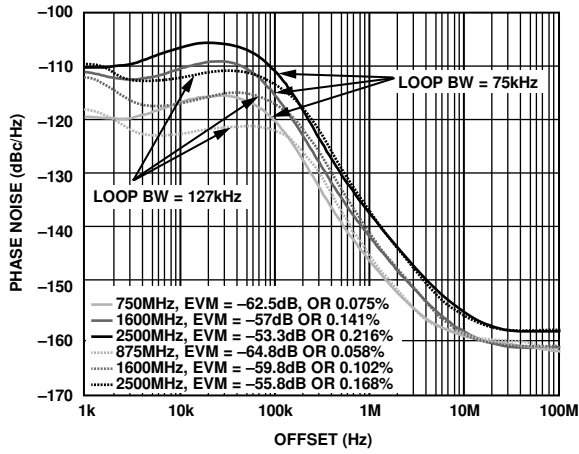

Figure 3. Typical Closed-Loop Integer Phase Noise, 50 MHz PD Frequency, Output Gain = 6 (VCO_REG 0x07[3:0] = 6d), High Performance Mode (VCO_REG 0x03[1:0] = 3d), Phase Noise Integrated from 1 kHz to 100 MHz, See Table 12

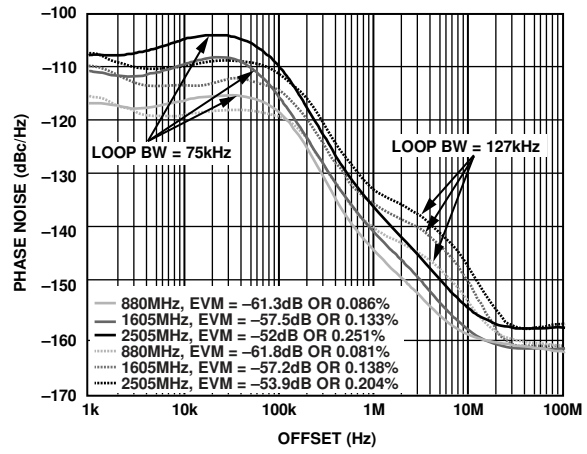

Figure 6. Typical Closed-Loop Fractional Phase Noise, 50 MHz PD Frequency, Output Gain = 6 (VCO_REG 0x07[3:0] = 6d), High Performance Mode (VCO_REG 0x03[1:0] = 3d), Phase Noise Integrated from 1 kHz to 100 MHz, See Table 12

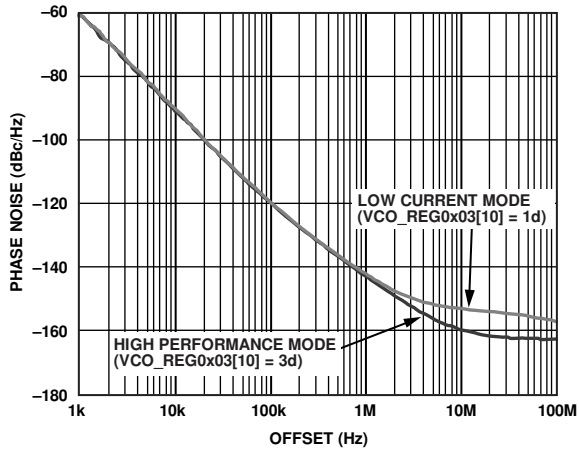

Figure 4. Open-Loop VCO Phase Noise at 1800 MHz

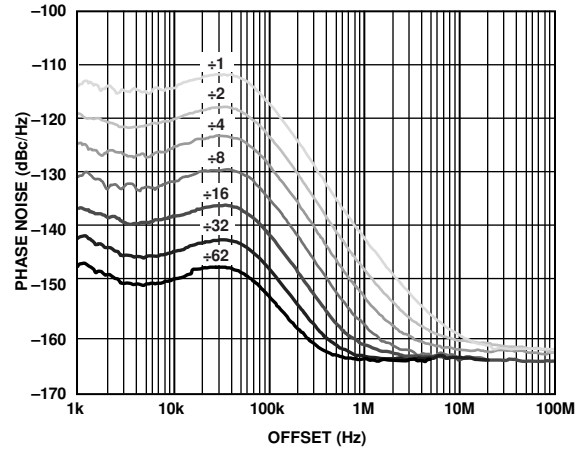

Figure 7. Closed-Loop Phase Noise at 1800 MHz, Divided by 1 to 62, PD Frequency, Loop Filter Bandwidth = 75 kHz (Type 2 from Table 12), High Performance Mode (VCO_REG 0x03[1:0] = 3d), Subset of Available Output Divide Ratios is Shown; Full Range of Output Divide Values Includes 1, 2, 4, 6, 8, ... 58, 60, 62

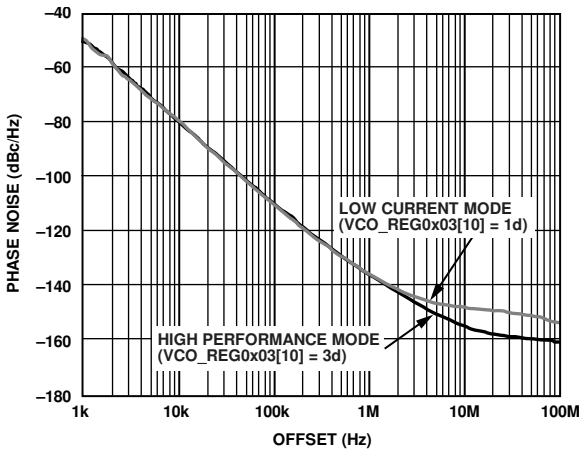

Figure 5. Free Running VCO Phase Noise at 3000 MHz

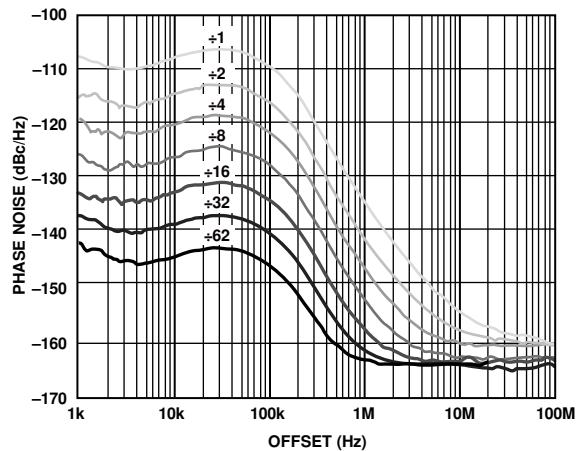

Figure 8. Closed-Loop Phase Noise at 3000 MHz, Divided by 1 to 62, PD Frequency, Loop Filter Bandwidth = 75 kHz (Type 2 from Table 12), High Performance Mode (VCO_REG 0x03[1:0] = 3d), Subset of Available Output Divide Ratios is Shown; Full Range of Output Divide Values Includes 1, 2, 4, 6, 8, ... 58, 60, 62

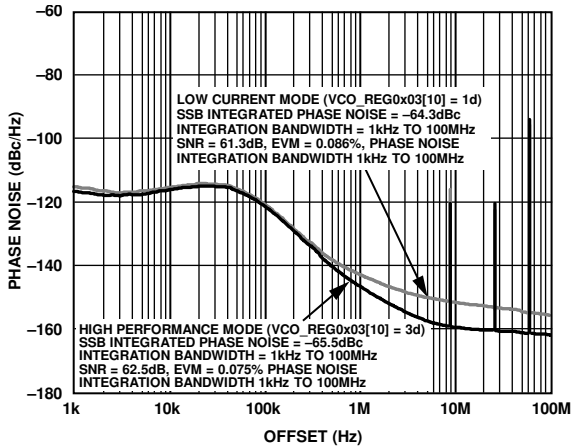

Figure 9. Fractional Spurious Performance at 904 MHz, Exact Frequency Mode On, 122.88 MHz XTAL, PFD = 61.44 MHz, Channel Spacing = 200 kHz, Loop Filter Type 2 (See Table 12)

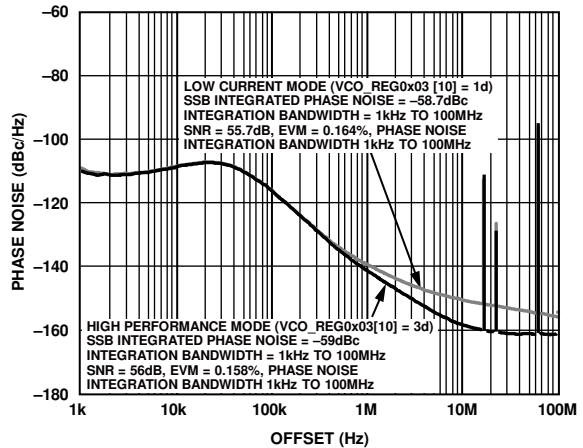

Figure 12. Fractional Spurious Performance at 1804 MHz, Exact Frequency Mode On, 122.88 MHz XTAL, PFD = 61.44 MHz, Channel Spacing = 200 kHz, Loop Filter Type 2 (See Table 12)

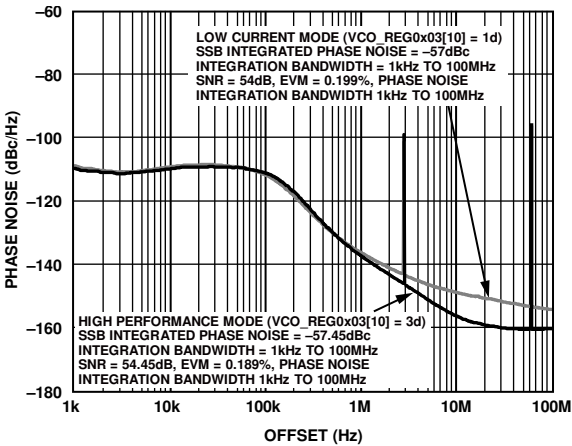

Figure 10. Fractional Spurious Performance at 2118.24 MHz, Exact Frequency Mode On, 122.88 MHz XTAL, PFD = 61.44 MHz, Channel Spacing = 240 kHz, Loop Filter Type 2 (See Table 12)

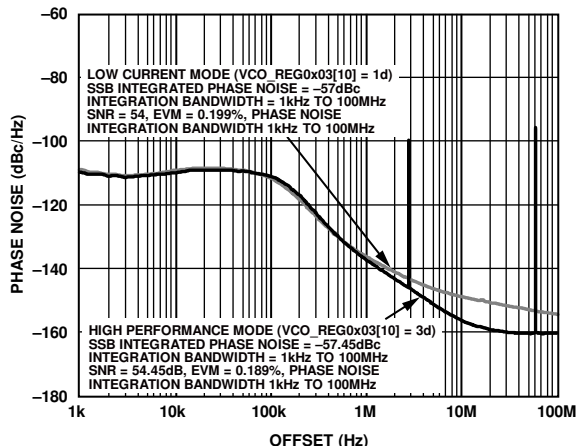

Figure 13. Fractional Spurious Performance at 2118.24 MHz, Identical Configuration to Figure 10 with Exact Frequency Mode Off

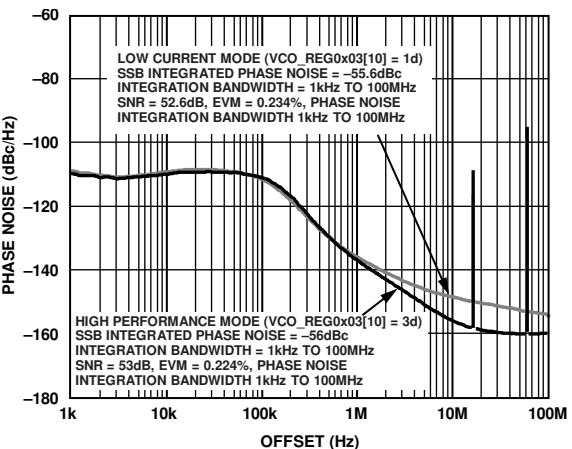

Figure 11. Fractional Spurious Performance at 2646.96 MHz, Exact Frequency Mode On, 122.88 MHz XTAL, PFD = 61.44 MHz, Channel Spacing = 240 kHz, Loop Filter Type 2 (See Table 12)

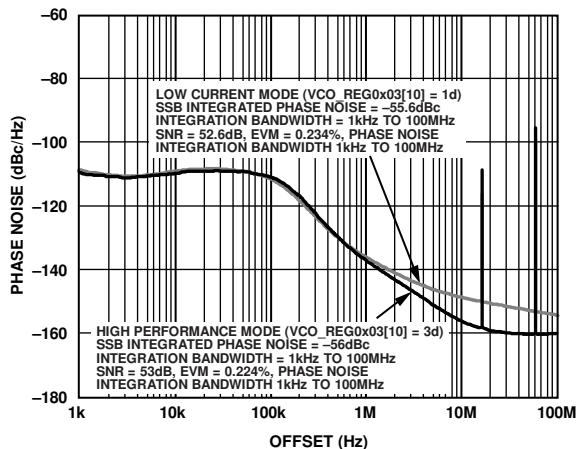

Figure 14. Fractional Spurious Performance at 2646.96 MHz, Identical Configuration to Figure 11 with Exact Frequency Mode Off

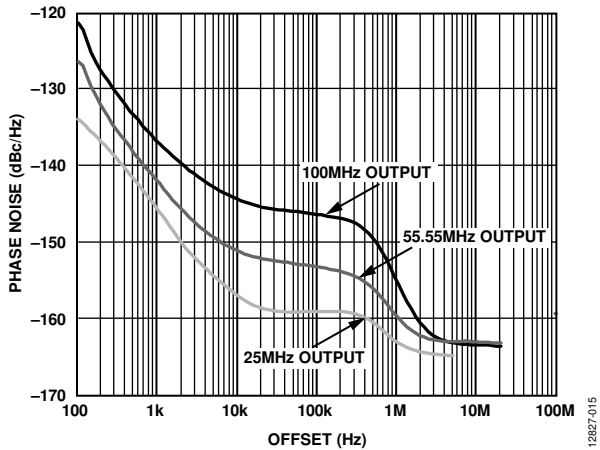

Figure 15. Low Frequency Performance, 100 MHz XTAL, PD Frequency = 50 MHz, Loop Filter Type 3 (See Table 12), Integer Mode, 50 MHz Low-Pass Filter at the Output of HMC832 for the 25 MHz Curve Only, Charge Pump Set to Maximum Value

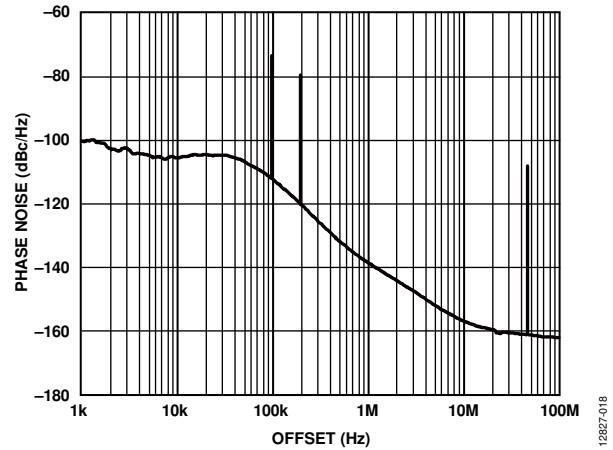

Figure 18. Typical Spurious Emissions at 2000.1 MHz, 50 MHz Fixed Reference, 50 MHz PD Frequency, Integer Boundary Spur Inside the Loop Filter Bandwidth (See the Loop Filter and Frequency Changes Section)

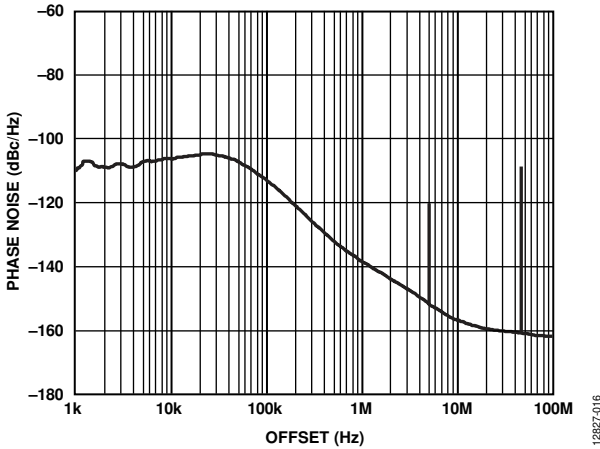

Figure 16. Typical Spurious Emissions at 2000.1 MHz, Tunable Reference, Loop Filter Type 2 (see Table 12 and the Loop Filter and Frequency Changes Section)

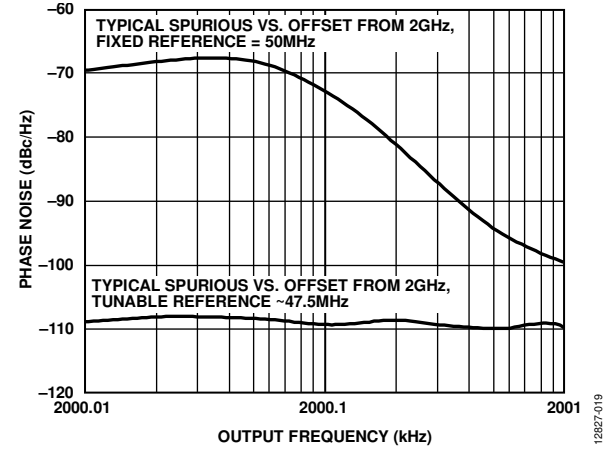

Figure 19. Typical Spurious vs. Offset from 2 GHz, Fixed 50 MHz Reference vs. Tunable 47.5 MHz Reference (See the Loop Filter and Frequency Changes Section)

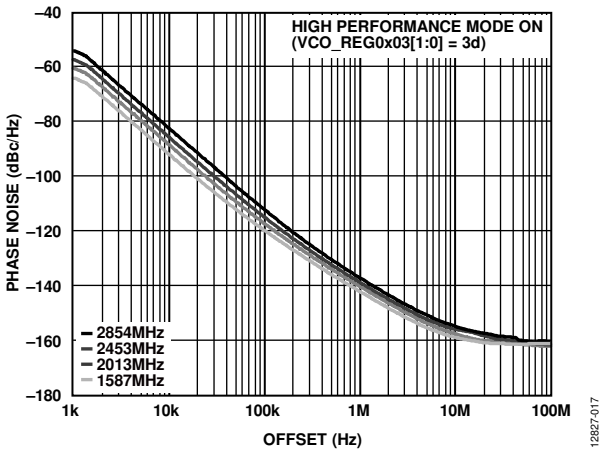

Figure 17. Open-Loop Phase Noise

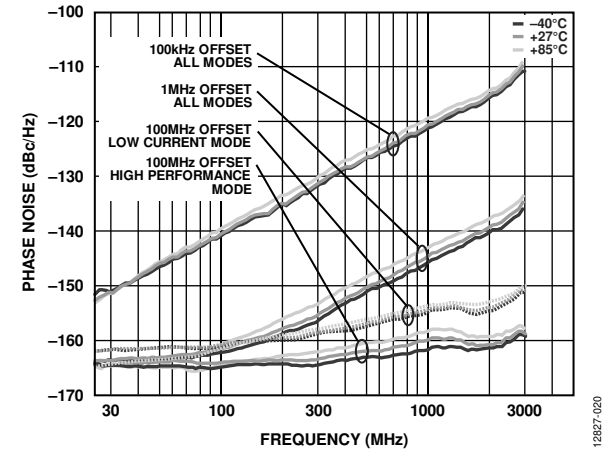

Figure 20. Open-Loop Phase Noise vs. Frequency at Various Temperatures

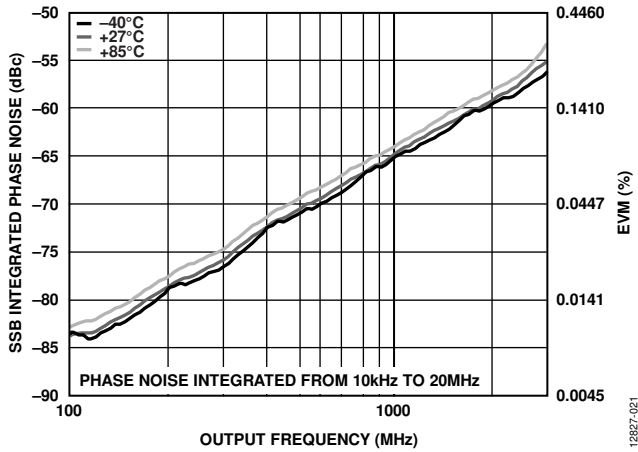

Figure 21. Single Sideband Integrated Phase Noise, High Performance Mode, Loop Filter Type 2 (See Table 12)

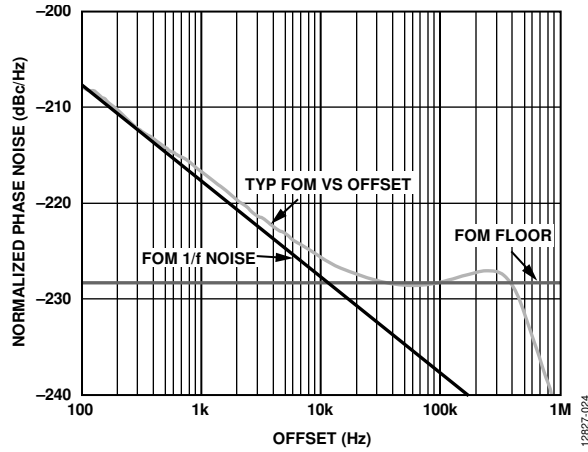

Figure 24. Figure of Merit

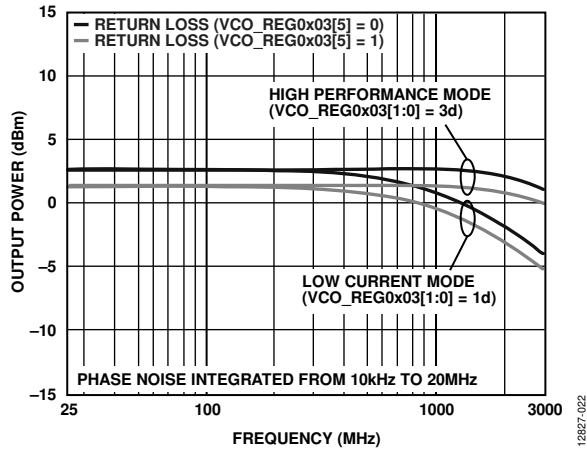

Figure 22. Typical Single-Ended Output Power vs. Frequency (Mid Gain Setting 6)

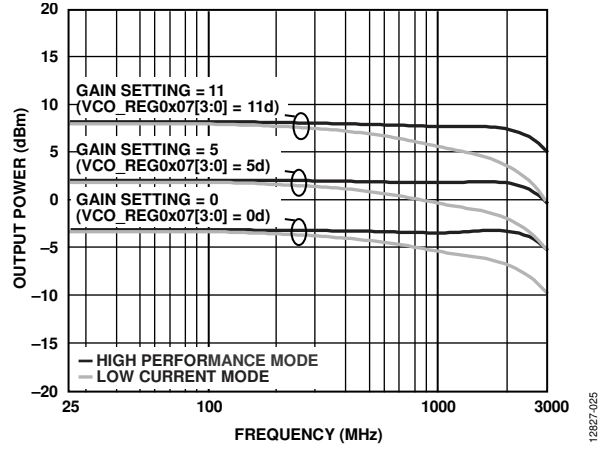

Figure 25. Typical Output Power vs. Frequency and Gain (Single-Ended)

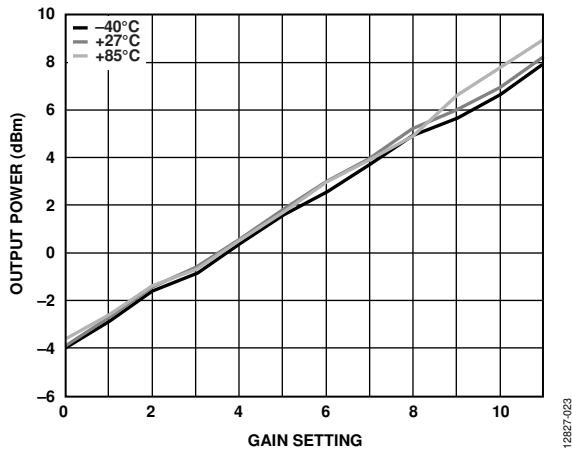

Figure 23. Typical RF Output Power at 2 GHz (Single-Ended) vs. Temperature

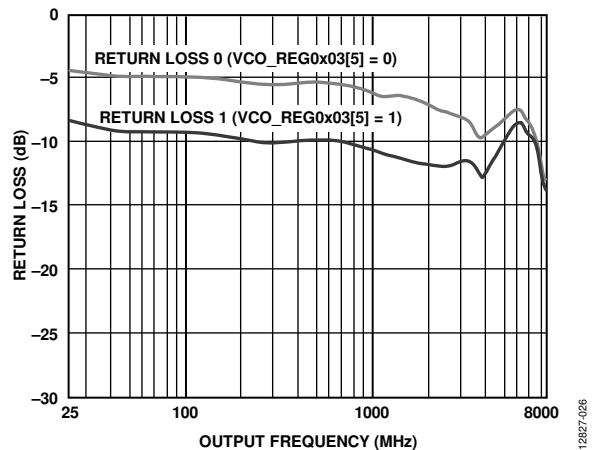

Figure 26. RF Output Return Loss

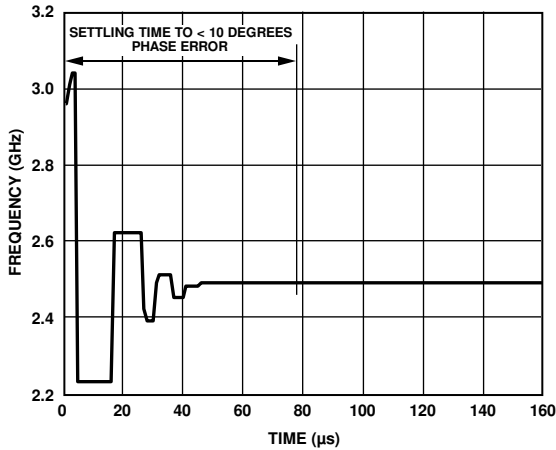

Figure 27. Frequency Settling After Frequency Change, Autocalibration Enabled, Loop Filter BW = 127 kHz (Type 1, See Table 12)

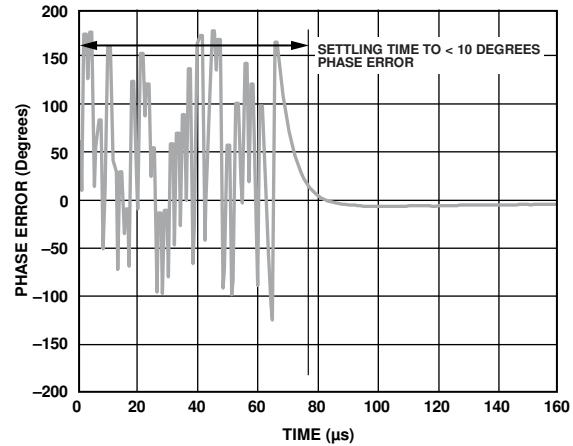

Figure 30. Phase Settling After Frequency Change, Autocalibration Enabled Loop Filter BW = 127 kHz (Type 1, See Table 12)

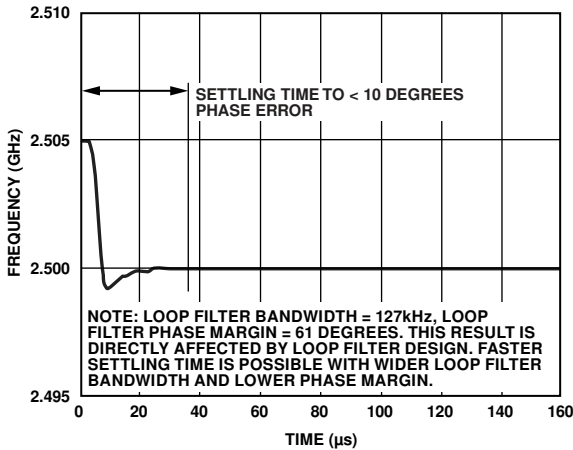

Figure 28. Frequency Settling After Frequency Change, Manual Calibration, Loop Filter BW = 127 kHz (Type 1 in Table 12)

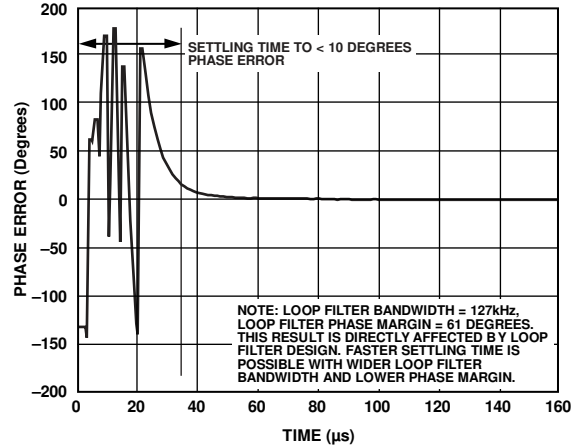

Figure 31. Phase Settling After Frequency Change, Manual Calibration

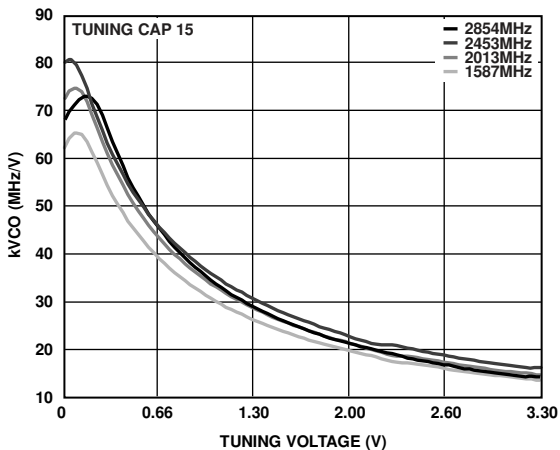

Figure 29. Typical VCO Sensitivity

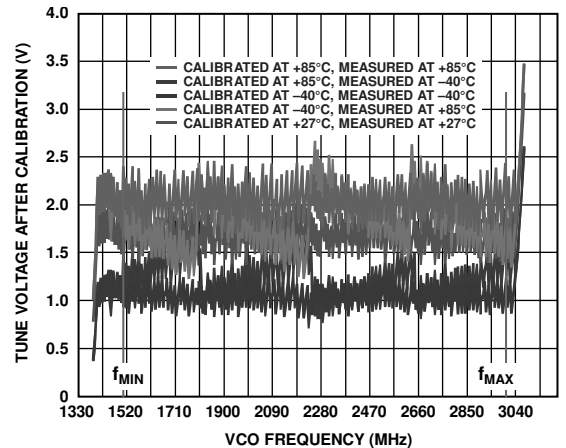

Figure 32. Typical Tuning Voltage After Calibration (See the Loop Filter and Frequency Changes Section)

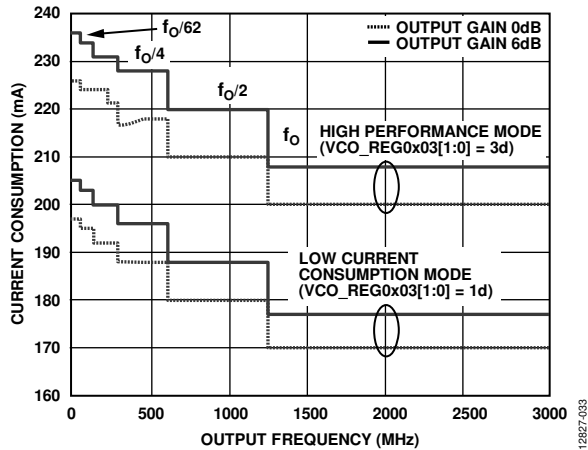

Figure 33. Current Consumption in Single-Ended Output Configuration, Output Gain Configured in VCO_REG 0x07[3:0], Differential or Single-Ended Mode Programmed in VCO_REG 0x03[3:2]

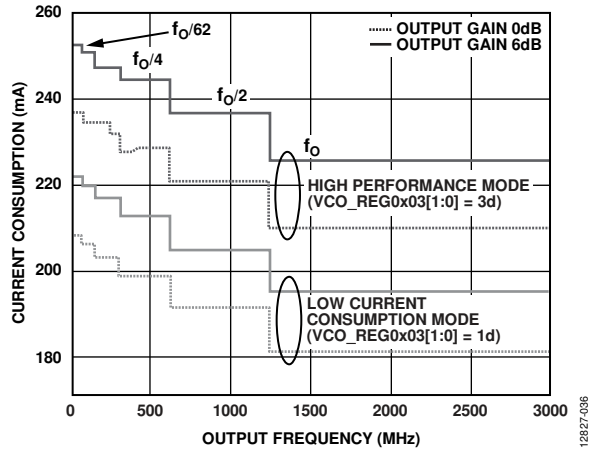

Figure 36. Current Consumption in Differential Output Configuration, Output Gain Configured in VCO_REG 0x07[3:0], Differential or Single-Ended Mode Programmed in VCO_REG 0x03[3:2]

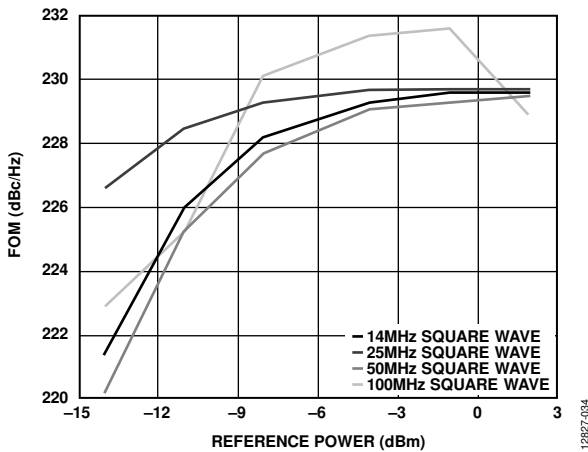

Figure 34. Reference Input Sensitivity, Square Wave, Measured from a 50 Ω Source with a 100 Ω External Resistor Termination

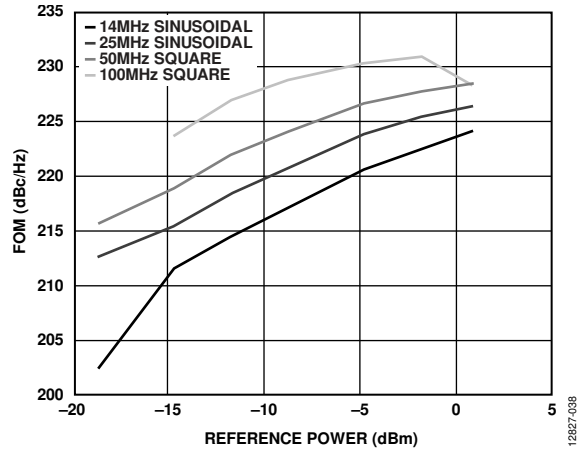

Figure 37. Reference Input Sensitivity, Sinusoidal Wave, Measured from a 50 Ω Source with a 100 Ω External Resistor Termination

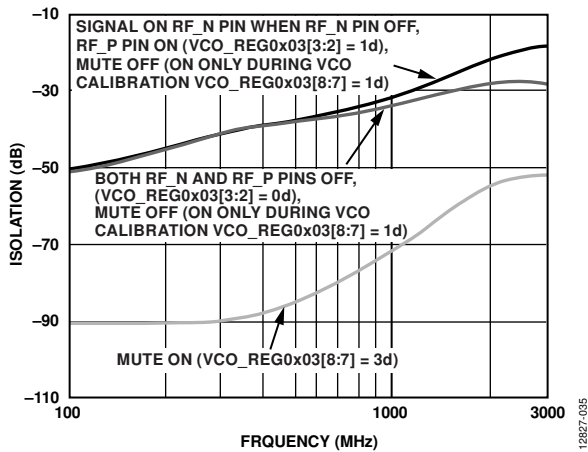

Figure 35. Mute Mode Isolation, Measured at Output

THEORY OF OPERATION

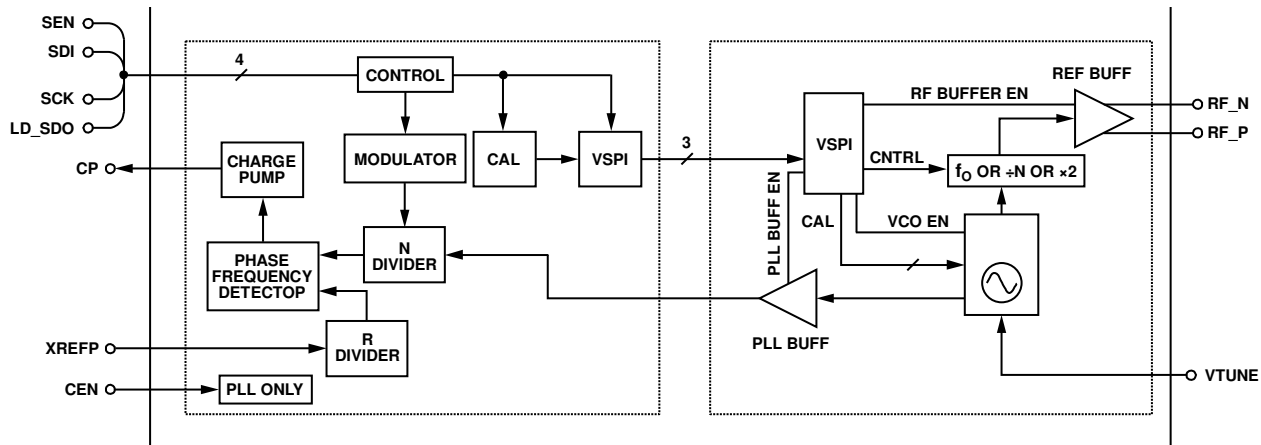

Figure 38. PLL and VCO Subsystems

The HMC832 PLL with integrated VCO is comprised of two subsystems; PLL subsystem and VCO subsystem, as shown in Figure 38.

PLL SUBSYSTEM OVERVIEW

The PLL subsystem divides down the VCO output to the desired comparison frequency via the N-divider (integer value set in Register 0x03, fractional value set in Register 0x04), compares the divided VCO signal to the divided reference signal (reference divider set in Register 0x02) in the phase detector (PD), and drives the VCO tuning voltage via the charge pump (CP) (configured in Register 0x09) to the VCO subsystem. Some of the additional PLL subsystem functions include

- Delta-sigma configuration (Register 0x06).
- Exact frequency mode (configured in Register 0x0C, Register 0x03, and Register 0x04).
- Lock detect (LD) configuration (use Register 0x07 to configure LD and Register 0x0F to configure the LD_SDO output pin).
- External CEN pin used for the hardware PLL enable pin. CEN pin does not affect the VCO subsystem.

Typically, only writes to the divider registers (integer part uses Register 0x03, fractional part uses Register 0x04) of the PLL subsystem are required for HMC832 output frequency changes.

Divider registers of the PLL subsystem (Register 0x03 and Register 0x04), set the fundamental frequency (1500 MHz to 3000 MHz) of the VCO subsystem. Output frequencies ranging from 25 MHz to 1500 MHz are generated by tuning to the appropriate fundamental VCO frequency (1500 MHz to 3000 MHz) by programming the N divider (Register 0x03 and Register 0x04) and programming the output divider (divide by 1/2/4/6 ... /60/62, in VCO_REG 0x02) in the VCO subsystem.

For detailed frequency tuning information and example, see the Frequency Tuning section.

VCO SUBSYSTEM OVERVIEW

The VCO subsystem consists of a capacitor switched step tuned VCO and an output stage. In typical operation, the VCO subsystem is programmed with the appropriate capacitor switch setting that is executed automatically by the PLL subsystem autocalibration state machine when autocalibration is enabled (Register 0x0A[11] = 0, see the VCO Calibration section for more information). The VCO tunes to the fundamental frequency (1500 MHz to 3000 MHz), and is locked by the CP output from the PLL subsystem. The VCO subsystem controls the output stage of the HMC832 enabling configuration of

- User defined performance settings (see the Programmable Performance Technology section) that are configured via VCO_REG 0x03[1:0].
- VCO output divider settings that are configured in the VCO_REG 0x02 (divide by 2/4/6 ... 60/62 to generate frequencies from 25 MHz to 1500 MHz, or divide by 1 to generate fundamental frequencies between 1500 MHz and 3000 MHz).
- Output gain settings (VCO_REG 0x07[3:0]).
- Output return loss setting (VCO_REG 0x03[5]). See Figure 26 for more information.
- Single-ended or differential output operation (VCO_REG 0x03[3:2]).
- Mute (VCO_REG 0x03[8:7]).

SPI (SERIAL PORT INTERFACE) CONFIGURATION OF PLL AND VCO SUBSYSTEMS

The two subsystems (PLL subsystem and VCO subsystem) have their own register maps as shown in the PLL Register Map and VCO Subsystem Register Map sections. Typically, writes to both register maps are required for initialization and frequency tuning operations.

As shown in Figure 38, the PLL subsystem is connected directly to the SPI of the HMC832, whereas the VCO subsystem is connected indirectly through the PLL subsystem to the

HMC832 SPI. As a result, writes to the PLL Register Map are written directly and immediately, whereas the writes to the VCO Subsystem Register Map are written to the PLL subsystem Register 0x05 and forwarded via the internal VCO SPI (VSPI) to the VCO subsystem. This is a form of indirect addressing.

Note that VCO subsystem registers are write only and cannot be read. More information is available in the VCO Serial Port Interface (VSPI) section.

VCO Serial Port Interface (VSPI)

The **HMC832** communicates with the internal VCO subsystem via an internal 16-bit VCO SPI. The internal serial port controls the step tuned VCO and other VCO subsystem functions.

Note that the internal VCO subsystem SPI (VSPI) runs at the rate of the autocalibration FSM clock, t_{FSM} , (see the VCO Autocalibration section) where the FSM clock frequency cannot be greater than 50 MHz. The VSPI clock rate is set by Register 0x0A[14:13].

Writes to the control registers of the VCO are handled indirectly via writes to Register 0x05 of the **HMC832**. A write to **HMC832** Register 0x05 causes the internal PLL subsystem to forward the packet, MSB first, across its internal serial link to the VCO subsystem, where it is interpreted.

VSPI Use of Register 0x05

The packet data written into Register 0x05 is subparsed by logic at the VCO subsystem into the following three fields:

Field 1—Bits[2:0]: 3-bit VCO_ID, target subsystem address = 000b.

Field 2—Bits[6:3]: 4-bit VCO_REGADDR, the internal register address inside the VCO subsystem.

Field 3—Bits[15:7]: 9-bit VCO_DATA, data field to write to the VCO register.

For example, to write 0_1111_1110 into Register 2 of the VCO subsystem (VCO_ID = 000b), and set the VCO output divider to divide by 62, the following needs to be written to Register 0x05 = 0_1111_1110b, 0010b, 000b or equivalently, Register 0x05 = 7F10.

During autocalibration, the autocalibration controller writes into the VCO register address specified by the VCO_ID and VCO_REGADDR, as stored in Register 0x05[2:0] and Register 0x05[6:3], respectively. Autocalibration requires that these values be zero (Register 0x05[6:0] = 0); otherwise, when

they are not zero (Register 0x05[6:0] \neq 0), autocalibration does not function.

To ensure that the autocalibration functions, it is critical to write Register 0x05[6:0] = 0 after the last VCO subsystem write prior to an output frequency change triggered by a write to either Register 0x03 or Register 0x04.

However, it is impossible to write only Register 0x05[6:0] = 0 (VCO_REGADDR) without writing Register 0x05[15:7] (VCO_DATA). Therefore, to ensure that the VCO_DATA (Register 0x05[15:7]) in VCO_REGADDR 0x00 is not changed, it is required to read the switch settings provided in Register 0x10[7:0], and then rewrite them to Register 0x05[15:7], as shown in the following example:

1. Read Register 0x10
2. Write to Register 0x05 the following:
 - a. Register 0x05[15:14] = Register 0x10[7:6]
 - b. Register 0x05[13] = 1, reserved bit
 - c. Register 0x05[12:8] = Register 0x10[4:0]
 - d. Register 0x05[7:0] = 0

Changing the VCO subsystem configuration (VCO Subsystem Register Map section) without following this procedure results in a failure to lock to the desired frequency.

For applications not using the read functionality of the **HMC832** SPI, in which Register 0x10 cannot be read, it is possible to write Register 0x05 = 0x0 to set Register 0x05[6:0] = 0, which also sets the VCO subband setting equal to zero (Register 0x05[15:7] = 0), effectively programming incorrect VCO subband settings and causing the **HMC832** to lose lock. This procedure is then immediately followed by a write to:

- Register 0x03, if in integer mode.
- Register 0x04, if in fractional mode.

This write effectively retriggers the autocalibration state machine, forcing the **HMC832** to relock whether in integer or fractional mode.

This procedure causes the **HMC832** to lose lock and relock after every VCO subsystem change. Typical output frequency and lock time is shown in Figure 27 and Figure 30, and is typically in the order of 100 μ s for a phase settling of 10°, and is also dependent on loop filter design (loop filter bandwidth and loop filter phase margin).

VCO SUBSYSTEM

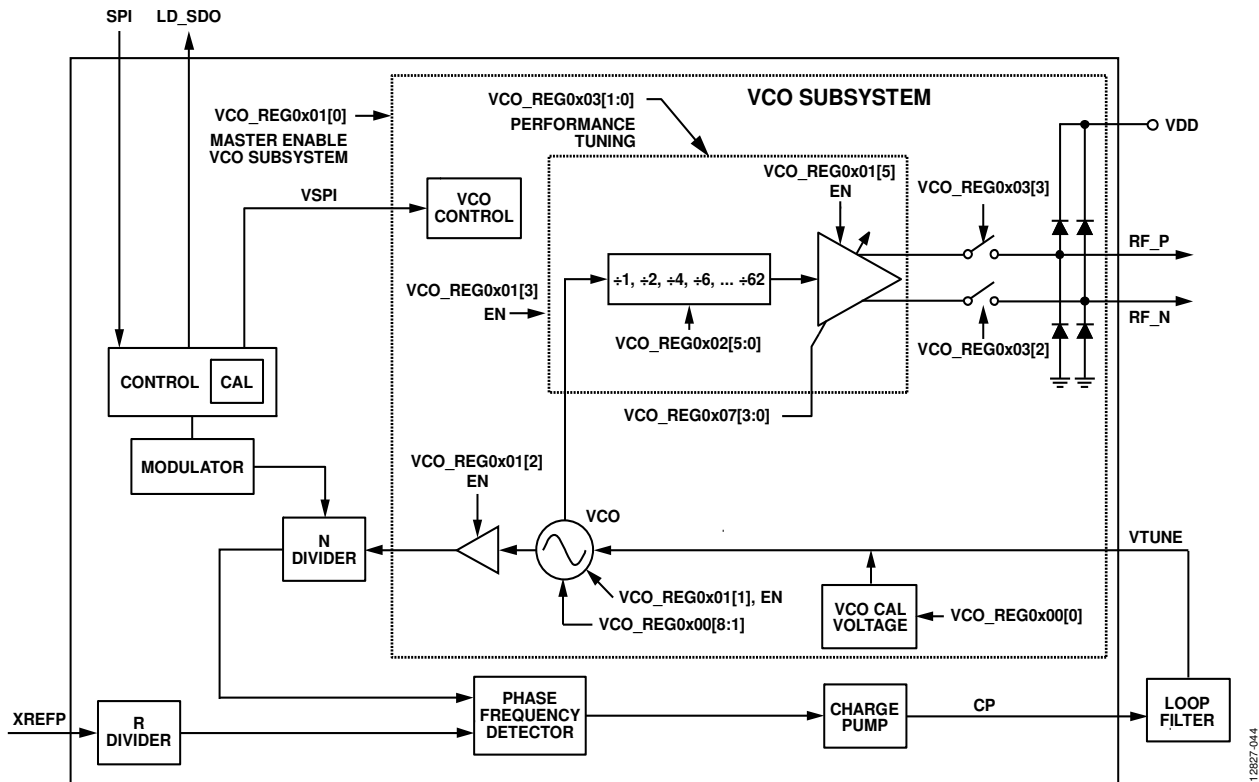

Figure 39. PLL and VCO Subsystems

The HMC832 contains a VCO subsystem that can be configured to operate in:

- Fundamental frequency (f_0) mode (1500 MHz to 3000 MHz).
- Divide by N mode, where $N = 2, 4, 6, 8 \dots 58, 60, 62$ (25 MHz to 1500 MHz).

All modes are VCO register programmable, as shown in Figure 39. One loop filter design can be used for the entire frequency of operation of the HMC832.

VCO Calibration

VCO Autocalibration

The HMC832 uses a step tuned type VCO. A simplified step tuned VCO is shown in Figure 41. A step tuned VCO is a VCO with a digitally selectable capacitor bank allowing the nominal center frequency of the VCO to be adjusted or stepped by switching in and out of the VCO tank capacitors. Note that more than one capacitor can be switched in at a time.

A step tuned VCO allows the user to center the VCO on the required output frequency while keeping the varactor tuning voltage optimized near the mid voltage tuning point of the HMC832 charge pump. This enables the PLL charge pump to tune the VCO over the full range of operation with both a low tuning voltage and a low tuning sensitivity (k_{VCO}).

The VCO switches are normally controlled automatically by the HMC832 using the autocalibration feature. The autocalibration

feature is implemented in the internal state machine. It manages the selection of the VCO subband (capacitor selection) when a new frequency is programmed. The VCO switches may also be controlled directly via Register 0x05 for testing or for other special purpose operations. Other control bits specific to the VCO are also sent via Register 0x05.

To use a step tuned VCO in a closed loop, the VCO must be calibrated such that the HMC832 knows which switch position on the VCO is optimum for the desired output frequency. The HMC832 supports autocalibration of the step tuned VCO. The autocalibration fixes the VCO tuning voltage at the optimum midpoint of the charge pump output, then measures the free running VCO frequency while searching for the setting which results in the free running output frequency that is closest to the desired phase-locked frequency. This procedure results in a phase-locked oscillator that locks over a narrow voltage range on the varactor. A typical tuning curve for a step tuned VCO is shown in Figure 40. Note that the tuning voltage stays in a narrow range over a wide range of output frequencies.

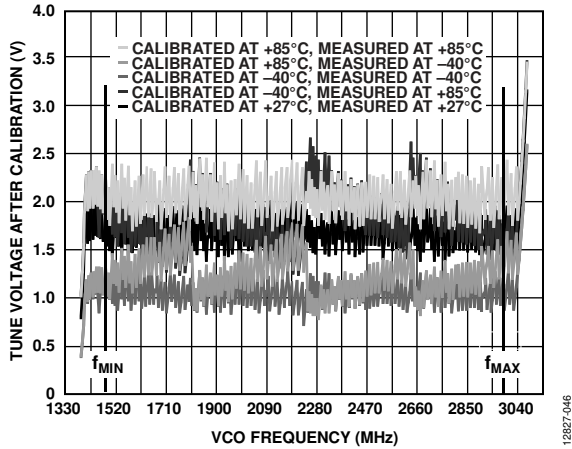

Figure 40. Typical VCO Tuning Voltage After Calibration

The calibration is normally run automatically, once for every change of frequency. This ensures optimum selection of VCO

switch settings vs. time and temperature. The user does not normally need to be concerned about which switch setting is used for a given frequency because this is handled by the autocalibration routine.

The accuracy required in the calibration affects the amount of time required to tune the VCO. The calibration routine searches for the best step setting that locks the VCO at the current programmed frequency and ensures that the VCO stays locked and performs well over its full temperature range without additional calibration, regardless of the temperature at which the VCO was calibrated.

Autocalibration can also be disabled, thereby allowing manual VCO tuning. Refer to the Manual VCO Calibration for Fast Frequency Hopping section for a description of manual tuning.

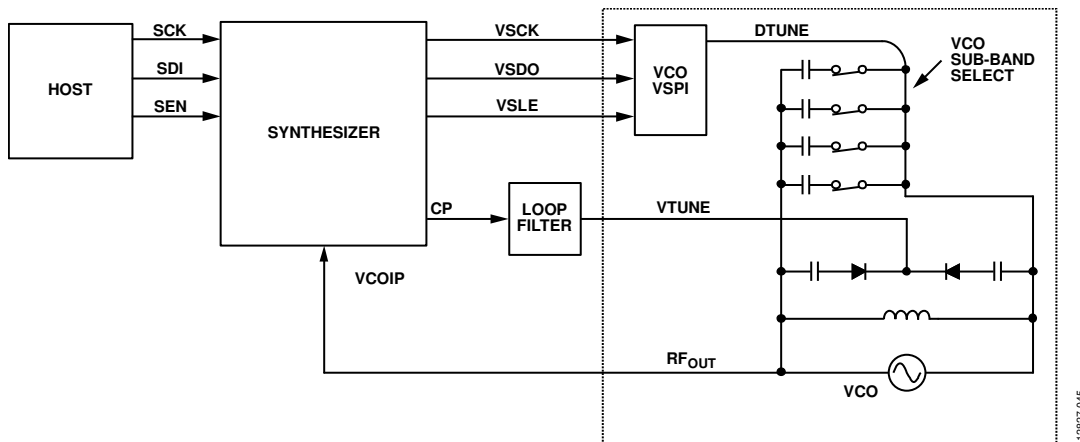

Figure 41. Simplified Step Tuned VCO

Autocalibration Using Register 0x05

Autocalibration transfers switch control data to the VCO subsystem via Register 0x05. The address of the VCO subsystem in Register 0x05 is not altered by the autocalibration routine. The address and ID of the VCO subsystem in Register 0x05 must be set to the correct value before autocalibration is executed. For more information see the VCO Serial Port Interface (VSPI) section.

Automatic Relock on Lock Detect Failure

It is possible by setting Register 0x07[13] to have the VCO subsystem automatically rerun the calibration routine and relock itself if lock detect indicates an unlocked condition for any reason. With this option the system attempts to relock only once.

VCO Autocalibration on Frequency Change

Assuming Register 0x0A[11] = 0, the VCO calibration starts automatically whenever a frequency change is requested. If it is desired to rerun the autocalibration routine for any reason at the same frequency, rewrite the frequency change with the same value and the autocalibration routine executes again without changing the final frequency.

VCO Autocalibration Time and Accuracy

The VCO frequency is counted for t_{MMT} , the period of a single autocalibration measurement cycle.

$$t_{MMT} = t_{XTAL} \times R \times 2^n \tag{1}$$

where:

n is set by Register 0x0A[2:0] and results in measurement periods which are multiples of the PD period, $t_{XTAL}R$.

R is the reference path division ratio currently in use, Register 0x02.

t_{XTAL} is the period of the external reference (crystal) oscillator.

The VCO autocalibration counter, on average, expects to register N counts, rounded down (floor) to the nearest integer, for every PD cycle.

N is the ratio of the target VCO frequency, f_{VCO} , to the frequency of the PD, f_{PD} , where N can be any rational number supported by the N divider.

N is set by the integer (N_{INT} = Register 0x03) and fractional (N_{FRAC} = Register 0x04) register contents by Equation 2.

$$N = N_{INT} + N_{FRAC}/2^{24} \tag{2}$$

The autocalibration state machine and the data transfers to the internal VCO subsystem SPI (VSPI) run at the rate of the FSM clock, t_{FSM} , where the FSM clock frequency cannot be greater than 50 MHz.

$$t_{FSM} = t_{XTAL} \times 2^m \tag{3}$$

where m is 0, 2, 4, or 5 as determined by Register 0x0A[14:13].

The expected number of VCO counts, V , is given by

$$V = \text{floor}(N \times 2^n) \tag{4}$$

The nominal VCO frequency measured, f_{VCOM} , is given by

$$f_{VCOM} = V \times f_{XTAL}/(2^n \times R) \tag{5}$$

where the worst case measurement error, f_{ERR} , is

$$f_{ERR} \approx \pm f_{PD}/2^{n+1} \tag{6}$$

A 5-bit step tuned VCO, for example, nominally requires five measurements for calibration or in the worst case, six measurements, and hence, seven VSPI data transfers of 20 clock cycles each. The measurement has a programmable number of wait states, k , of 128 FSM cycles defined by Register 0x0A[7:6] = k . Total calibration time, worst case, is given by

$$t_{CAL} = k128 t_{FSM} + 6t_{PD} 2^n + 7 \times 20 t_{FSM} \tag{7}$$

or equivalently

$$t_{CAL} = t_{XTAL} (6R \times 2^n + (140+(k \times 128)) \times 2^m) \tag{8}$$

For guaranteed hold of lock, across temperature extremes, the resolution should be better than 1/8th the frequency step caused by a VCO subband switch change. Better resolution settings show no improvement.

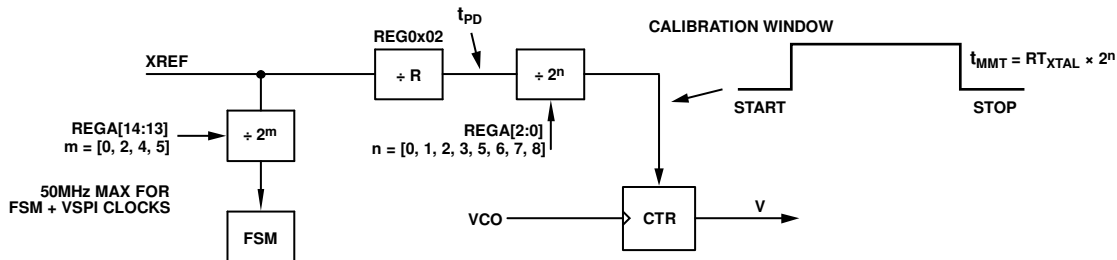

Figure 42. VCO Calibration

Table 7. Autocalibration Example with $f_{XTAL} = 50$ MHz, $R = 1$, $m = 0$

Control Value Register 0x0A[2:0]	n	2^n	t_{MMT} (μ s)	t_{CAL} (μ s)	f_{ERR} Maximum
0	0	1	0.02	4.92	± 25 MHz
1	1	2	0.04	5.04	± 12.5 MHz
2	2	4	0.08	5.28	± 6.25 MHz
3	3	8	0.16	5.76	± 3.125 MHz
4	5	32	0.64	8.64	± 781 kHz

Control Value Register 0x0A[2:0]	n	2 ⁿ	t _{MMT} (μs)	t _{CAL} (μs)	f _{FERR} Maximum
5	6	64	1.28	12.48	±390 kHz
6	7	128	2.56	20.16	± 95 kHz
7	8	256	5.12	35.52	±98 kHz

VCO Autocalibration Example

The VCO subsystem must satisfy the maximum f_{PD} limited by the two following conditions:

$$N \geq 16 (f_{INT}), N \geq 20.0 (f_{FRAC})$$

where $N = f_{VCO} / f_{PD}$.

$$f_{PD} \leq 100 \text{ MHz}$$

For example, if the VCO subsystem output frequency is to operate at 2.01 GHz and the crystal frequency is $f_{XTAL} = 50 \text{ MHz}$, $R = 1$, and $m = 0$ (see Figure 42), then $t_{FSM} = 20 \text{ ns}$ (50 MHz).

Note that when using autocalibration, the maximum autocalibration finite state machine (FSM) clock cannot exceed 50 MHz (see Register 0x0A[14:13]). The FSM clock does not affect the accuracy of the measurement, it only affects the time to produce the result. This same clock is used to clock the 16-bit VCO serial port.

If time to change frequencies is not a concern, then the calibration time for maximum accuracy can be set, and therefore, the measurement resolution is of no concern.

Using an input crystal of 50 MHz ($R = 1$ and $f_{PD} = 50 \text{ MHz}$) the times and accuracies for calibration using Equation 6 and Equation 8 are listed in Table 7, where minimal tuning time is 1/8th of the VCO band spacing.

Across all VCOs, a measurement resolution better than 800 kHz produces correct results. Setting $m = 0$ and $n = 5$, provides 781 kHz of resolution and adds 8.6 μs of autocalibration time to a normal frequency hop. After the autocalibration sets the final switch value, 8.64 μs after the frequency change command, the fractional register is loaded, and the loop locks with a normal transient predicted by the loop dynamics. Therefore, as shown in this example, autocalibration typically adds about 8.6 μs to the normal time to achieve frequency lock. Use autocalibration for all but the most extreme frequency hopping requirements.

Manual VCO Calibration for Fast Frequency Hopping

When switching frequencies quickly is needed, it is possible to eliminate the autocalibration time by calibrating the VCO in advance and storing the switch number vs. frequency information in the host. This is accomplished by initially locking the HMC832 on each desired frequency using autocalibration, then reading and storing the selected VCO switch settings. The VCO switch settings are available in Register 0x10[7:0] after every autocalibration operation. The host must then program the VCO switch settings directly when changing frequencies.

Manual writes to the VCO switches are executed immediately as are writes to the integer and fractional registers when autocalibration is disabled. Therefore, frequency changes with manual control and autocalibration disabled requires a minimum of two serial port transfers to the PLL, once to set the VCO switches and once to set the PLL frequency.

When autocalibration is disabled, Register 0x0A[11] = 1, the VCO updates its registers immediately with the value written via Register 0x05. The VCO internal transfer requires 16 VSCCK clock cycles after the completion of a write to Register 0x05. VSCCK and the autocalibration controller clock are equal to the input reference divided by 0, 4, 16, or 32 as controlled by Register 0x0A[14:13].

Registers Required for Frequency Changes in Fractional Mode

In fractional mode (Register 0x06[11] = 1), a large change of frequency may require main serial port writes to one of the three following registers

- The integer register, INTG, Register 0x03. This is required only if the integer part changes.
- The VCO SPI register, Register 0x05. This is required only for manual control of VCO if Register 0x0A[11] = 1, autocalibration is disabled, or to change the VCO output divider value (VCO_REG 0x02), see Figure 39 for more information.
- The fractional register, Register 0x04. The fractional register write triggers autocalibration when Register 0x0A[11] = 0, and it is loaded into the modulator automatically after the autocalibration runs. If autocalibration is disabled, Register 0x0A[11] = 1, the fractional frequency change is loaded immediately into the modulator when the register is written with no adjustment to the VCO.

Small steps in frequency in fractional mode, with autocalibration enabled (Register 0x0A[11] = 0), usually require only a single write to the fractional register. In a worst-case scenario, three main serial port transfers to the HMC832 could be required to change frequencies in fractional mode. If the frequency step is small and the integer part of the frequency does not change, then the integer register is not changed. In all cases, in fractional mode, it is necessary to write to the fractional register, Register 0x04, for frequency changes.

Registers Required for Frequency Changes in Integer Mode

In integer mode (Register 0x06[11] = 0), a change of frequency requires main serial port writes to the following registers:

- VCO SPI register, Register 0x05. This is required for manual control only of the VCO when Register 0x0A[11] = 1 (autocalibration disabled) or when the VCO output divider value must change (VCO_REG 0x02).
- Integer register, Register 0x03. In integer mode, an integer register write triggers autocalibration when Register 0x0A[11] = 0 and it is loaded into the prescaler automatically after autocalibration runs. If autocalibration is disabled, Register 0x0A[11] = 1, the integer frequency change is loaded into the prescaler immediately when written with no adjustment to the VCO. Normally, changes to the integer register cause large steps in the VCO frequency; therefore, the VCO switch settings must be adjusted. Autocalibration enabled is the recommended method for integer mode frequency changes. If autocalibration is disabled (Register 0x0A[11] = 1), a priori knowledge of the correct VCO switch setting and the corresponding adjustment to the VCO is required before executing the integer frequency change.

VCO Output Mute Function

The HMC832 features an intelligent output mute function with the capability to disable the VCO output while maintaining fully functional PLL and VCO subsystems. The mute function is automatically controlled by the HMC832 and provides a number of mute control options including

- Automatic mute. This option automatically mutes the outputs during VCO calibration during output frequency changes. This mode can be useful in eliminating any out of band emissions during frequency changes, and ensuring that the system emits only the desired frequencies. It is enabled by writing VCO_REG 0x03[8:7] = 1d.
- Always mute (VCO_REG 0x03[8:7] = 3d). This mode is used for manual mute control.

Typical isolation when the HMC832 is muted is always better than 50 dB, and is ~40 dB better than disabling the individual outputs of the HMC832 via VCO_REG 0x03[3:2], as shown in Figure 35.

Also note that the VCO subsystem registers are not directly accessible. They are written to the VCO subsystem via PLL Register 0x05. See Figure 39 and the VCO Serial Port Interface (VSPI) section for more information about the VCO subsystem SPI.

VCO Built-In Test (BIST) with Autocalibration

The frequency limits of the VCO can be measured using the BIST features of the autocalibration machine by setting Register 0x0A[10] = 1, which freezes the VCO switches in one position. VCO switches may then be written manually with the varactor biased at the nominal midrail voltage used for autocalibration. For example, to measure the VCO maximum frequency use Switch 0, written to the VCO subsystem via Register 0x05 = 000000001 0000 VCO_ID, where VCO_ID = 000b.

When autocalibration is enabled (Register 0x0A[11] = 0), and a new frequency is written, autocalibration runs. The VCO frequency error relative to the command frequency is measured and the results are written to Register 0x11[19:0], where Register 0x11[19] is the sign bit. The result is written in terms of VCO count error (see Equation 4).

For example, if the expected VCO is 2 GHz, the reference is 50 MHz, and n is 6, expect to measure $2000/(50/2^6) = 2560$ counts. If a difference of -5 counts is measured in Register 0x11, then it means 2555 counts were actually measured. Hence, the actual frequency of the VCO is $5/2560$ low, or 1.99609375 GHz, ± 1 count $\sim \pm 781$ kHz.

PLL SUBSYSTEM

Charge Pump (CP) and Phase Detector (PD)

The phase detector (PD) has two inputs, one from the reference path divider and one from the RF path divider. When in lock, these two inputs are at the same average frequency and are fixed at a constant average phase offset with respect to each other. The frequency of operation of the PD is f_{PD} . Most formulae related to step size, Δ - Σ modulation, timers, and so forth are functions of the operating frequency of the PD, f_{PD} . f_{PD} is also referred to as the comparison frequency of the PD.

The PD compares the phase of the RF path signal with that of the reference path signal and controls the charge pump output current as a linear function of the phase difference between the two signals. The output current varies linearly over a full $\pm 2\pi$ radians ($\pm 360^\circ$) of input phase difference.

Charge Pump

A simplified diagram of the charge pump is shown in Figure 43. The CP consists of four programmable current sources, two controlling the CP gain (Up Gain Register 0x09[13:7], and Down Gain Register 0x09[6:0]) and two controlling the CP offset, where the magnitude of the offset is set by Register 0x09[20:14], and the direction is selected by Register 0x09[21] = 1 for up and Register 0x09[22] = 1 for down offset.

CP gain is used at all times, whereas CP offset is recommended for fractional mode of operation only. Typically, the CP up and down gain settings are set to the same value (Register 0x09[13:7] = Register 0x09[6:0]).

Charge Pump Gain

Charge pump up and down gains are set by Register 0x09[6:0] and Register 0x09[13:7], respectively. The current gain of the pump in amps/radian is equal to the gain setting of this register (Register 0x09) divided by 2π .

Typical CP gain setting is set to 2 mA to 2.5 mA; however, lower values can also be used. Note that values less than 1 mA may result in degraded phase noise performance.

For example, if both Register 0x09[13:7] and Register 0x09[6:0] are set to 50 decimal, the output current of each pump is 1 mA, and the phase frequency detector gain is $k_P = 1 \text{ mA}/2\pi \text{ radians}$, or $159 \text{ }\mu\text{A}/\text{rad}$. See the Charge Pump (CP) and Phase Detector (PD) section for more information.

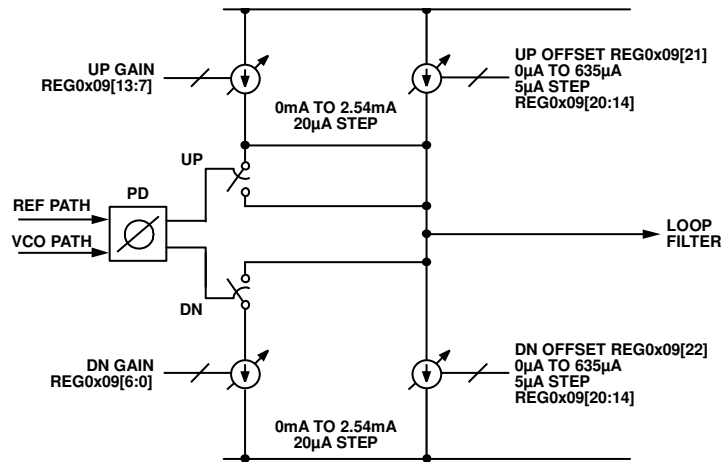

Figure 43. Charge Pump Gain and Offset Control

Charge Pump Phase Offset

In integer mode, the phase detector operates with zero offset. The divided reference signal and the divided VCO signal arrive at the phase detector inputs at the same time. Integer mode does not require any CP offset current. When operating in integer mode, disable CP offset in both directions (up and down) by writing Register 0x09[22:21] = 00b, and set the CP offset magnitude to zero by writing Register 0x09[20:14] = 0.

In fractional mode, CP linearity is of paramount importance. Any nonlinearity degrades phase noise and spurious performance. These nonlinearities are eliminated by operating the PD with an average phase offset, either positive or negative (either the reference or the VCO edge always arrives first at the PD, that is, leads).

A programmable CP offset current source is used to add dc current to the loop filter and to create the desired phase offset. Positive current causes the VCO to lead, negative current causes the reference to lead.

The CP offset is controlled via Register 0x09. The phase offset is scaled from 0° to 360°, where they arrive a full cycle late.

The specific level of charge pump offset current (Register 0x09, Bits[20:14]) is provided in Equation 9 and plotted in Figure 44.

$$\begin{aligned} \text{Required CP Offset} = \\ \min [(4.3 \times 10^{-9} \times f_{PD} \times I_{CP}), 0.25 \times I_{CP}] \end{aligned} \quad (9)$$

where:

f_{PD} is the comparison frequency of the phase detector (Hz).
 I_{CP} is the full-scale current setting (A) of the switching charge pump (set in Register 0x09[6:0] and Register 0x09[13:7]).

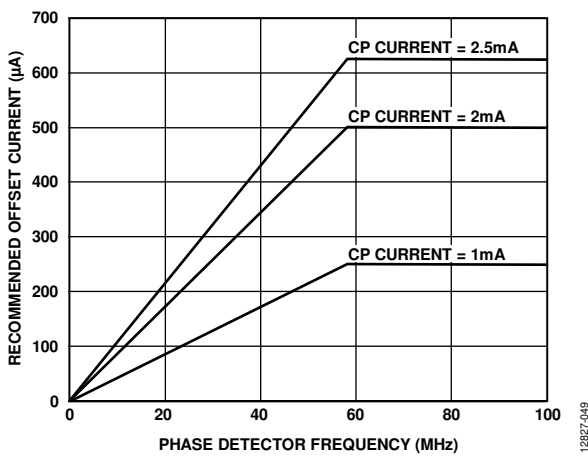

Figure 44. Recommended CP Offset Current vs. PD Frequency for Typical CP Gain Currents, Calculated Using Equation 9

Do not allow the required CP offset current to exceed 25% of the programmed CP current. It is recommended to enable the up offset and disable the down offset by writing Register 0x09, Bits[22:21] = 01b.

Operation with CP offset influences the required configuration of the lock detect function. See the description of the lock detect function in the Lock Detect section.

Phase Detector Functions

Register 0x0B, the phase detector register, allows manual access to control special phase detector features.

Setting Register 0x0B[5] = 0 masks the PD up output, which prevents the charge pump from pumping up.

Setting Register 0x0B[6] = 0, masks the PD down output, which prevents the charge pump from pumping down.

Clearing both Register 0x0B[5] and Register 0x0B[6] tristates the charge pump while leaving all other functions operating internally.

PD force up (Register 0x0B[9] = 1) and PD force down (Register 0x0B[10] = 1) allows the charge pump to be forced up or down, respectively. This forces the VCO to the ends of the tuning range, which is useful in testing the VCO.

Reference Input Stage

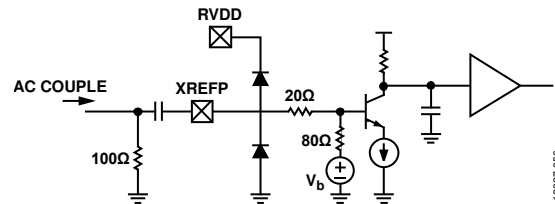

Figure 45. Reference Path Input Stage

The reference buffer provides the path from an external reference source (generally crystal-based) to the R divider, and eventually to the phase detector. The buffer has two modes of operation controlled by Register 0x08[21]. High gain (Register 0x08[21] = 0) is recommended below 200 MHz, and high frequency (Register 0x08[21] = 1) for 200 MHz to 350 MHz operation. The buffer is internally dc biased with 100 Ω internal termination. For a 50 Ω match, add an external 100 Ω resistor to ground followed by an ac coupling capacitor (impedance less than 1 Ω).

At low frequencies, a relatively square reference is recommended to maintain a high input slew rate. At higher frequencies, use a square or sinusoid.

Table 8 shows the recommended operating regions for different reference frequencies. If operating outside these regions, the device usually still operates, but with degraded reference path phase noise performance.

When operating at 50 MHz, the input referred phase noise of the PLL is between -148 dBc/Hz and -150 dBc/Hz at a 10 kHz offset, depending upon the mode of operation. To avoid degradation of the PLL noise contribution, the input reference signal should be 10 dB better than this floor. Note that such low levels are only necessary if the PLL is the dominant noise contributor and these levels are required for the system goals.

Table 8. Reference Sensitivity

Reference Input Frequency (MHz)	Square Input			Sinusoidal Input		
	Slew > 0.5 V/ns	Recommended Swing (V p-p)		Recommended	Recommended Power Range (dBm)	
	Recommended	Minimum	Maximum		Minimum	Maximum
<10	Yes	0.6	2.5	No	No	No
10	Yes	0.6	2.5	No	No	No
25	Yes	0.6	2.5	Okay	8	15
50	Yes	0.6	2.5	Yes	6	15
100	Yes	0.6	2.5	Yes	5	15
150	Okay	0.9	2.5	Yes	4	12
200	Okay	1.2	2.5	Yes	3	8

Reference Path, R Divider

The reference path, R divider is based on a 14-bit counter and can divide input signals by values from 1 to 16,383 and is controlled via Register 0x02.

RF Path, N Divider

The main RF path divider is capable of average divide ratios between $2^{19} - 5$ (524,283) and 20 in fractional mode, and $2^{19} - 1$ (524,287) to 16 in integer mode. The VCO frequency range divided by the minimum N divider value places practical restrictions on the maximum usable PD frequency. For example, a VCO operating at 1.5 GHz in fractional mode with a minimum N divider value of 20 has a maximum PD frequency of 75 MHz.

Lock Detect

The lock detect (LD) function verifies that the HMC832 is generating the desired frequency. It is enabled by writing Register 0x07[3] = 1. The HMC832 provides an LD indicator in one of two ways

- As an output available on the LD_SDO pin of the HMC832, (configuration is required to use the LD_SDO pin for LD purposes, for more information, see the Serial Port and Configuring the LD_SDO Pin for LD Output sections).
- Or reading from Register 0x12[1], where Bit 1 = 1 indicates a locked condition and Bit 1 = 0 indicates an unlocked condition.

The LD circuit expects the divided VCO edge and the divided reference edge to appear at the PD within a user specified time period (window), repeatedly. Either signal may arrive first, only the difference in arrival times is significant. The arrival of the two edges within the designated window increments an internal counter. When the count reaches and exceeds a user specified value (Register 0x07[2:0]) the HMC832 declares lock.

Failure in registering the two edges in any one window resets the counter and immediately declares an unlocked condition. Lock is deemed to be reestablished when the counter reaches the user specified value (Register 0x07[2:0]) again.

The HMC832 supports two lock detect modes:

- Analog LD, that only supports a fixed window size of 10 ns. Analog LD mode is selected by writing Register 0x07[6] = 0.
- Digital LD, that supports a user configurable window size, programmed in Register 0x07[11:7]. Digital LD is selected by writing Register 0x07[6] = 1.

Lock Detect Configuration

Optimal spectral performance in fractional mode requires CP current and CP offset current configuration discussed in detail in the Charge Pump (CP) and Phase Detector (PD) section.

These settings in Register 0x09 impact the required LD window size in fractional mode of operation. To function, the required lock detect window size is provided by Equation 10 in fractional mode and Equation 11 in integer mode.

$$LD \text{ Window (sec)} = \frac{\left(\frac{I_{CP \text{ Offset}} \text{ (A)}}{f_{PD} \text{ (Hz)} \times I_{CP} \text{ (A)}} + 2.66 \times 10^{-9} \text{ (sec)} + \frac{1}{f_{PD} \text{ (Hz)}} \right)}{2} \quad (10)$$

$$LD \text{ Window (sec)} = \frac{1}{2 \times f_{PD}} \quad (11)$$

where:

f_{PD} is the comparison frequency of the phase detector.

$I_{CP \text{ Offset}}$ is the charge pump offset current (Register 0x09[20:14]).

I_{CP} is the full-scale current setting of the switching charge pump (Register 0x09[6:0] or Register 0x09[13:7]).

If the result provided by Equation 10 is equal to 10 ns, analog LD can be used (Register 0x07[6] = 0); otherwise, digital LD is necessary (Register 0x07[6] = 1).

Table 9 lists the required Register 0x07 settings to appropriately program the digital LD window size. From Table 9, select the closest value in the digital LD window size columns to the ones calculated in Equation 10 and Equation 11, and program Register 0x07[11:10] and Register 0x07[9:7] accordingly.

Table 9. Typical Digital Lock Detect Window

LD Timer Speed Register 0x07 Bits[11:10]	Digital Lock Detect Window Size Nominal Value (ns)							
	6.5	8	11	17	29	53	100	195
Fastest 00	6.5	8	11	17	29	53	100	195
01	7	8.9	12.8	21	36	68	130	255
10	7.1	9.2	13.3	22	38	72	138	272
Slowest 11	7.6	10.2	15.4	26	47	88	172	338
LD Timer Divide Setting Register 0x07, Bits[9:7]	000	001	010	011	100	101	110	111

Digital Window Configuration Example

Assuming, fractional mode, with a 50 MHz PD and a

- Charge pump gain of 2 mA (Register 0x09[13:7] = 0x64, Register 0x09[6:0] = 0x64),
- Up offset (Register 0x09[22:21] = 01b)
- Offset current magnitude of +400 μ A (Register 0x09[20:14] = 0x50)

Applying Equation 10, the required LD window size is:

$$LD \text{ Window (sec)} = \frac{\left(\frac{0.4 \times 10^{-3} \text{ (A)}}{50 \times 10^6 \text{ (Hz)} \times 2 \times 10^{-3} \text{ (A)}} + 2.66 \times 10^{-9} \text{ (sec)} + \frac{1}{50 \times 10^6 \text{ (Hz)}} \right)}{2}$$

$$= 13.33 \text{ ns}$$

Locating the Table 9 value that is closest to this result is, in this case, 13.3 \approx 13.33. To set the digital LD window size, program Register 0x07[11:10] = 10b and Register 0x07[9:7] = 010b, according to Table 9.

There is always a good solution for the lock detect window for a given operating point. The user should understand, however, that one solution does not fit all operating points. As observed from Equation 10 and Equation 11, if the charge pump offset or PD frequency is changed significantly, then the lock detect window may need to be adjusted.

Configuring the LD_SDO Pin for LD Output

Setting Register 0x0F[7] = 1 and Register 0x0F[4:0] = 1 displays the lock detect flag on the LD_SDO pin of the HMC832. When locked, LD_SDO is high. As the name suggests, LD_SDO pin is multiplexed between the LD and the serial data output (SDO) signals. Therefore, LD is available on the LD_SDO pin at all times except when a serial port read is requested, in which case the pin reverts temporarily to the serial data output pin, and returns to the lock detect flag after the read is completed.

LD can be made available on LD_SDO pin at all times by writing Register 0x0F[6] = 1. In that case, the HMC832 does not provide any readback functionality because the SDO signal is not available.

Cycle Slip Prevention (CSP)

When changing VCO frequency and the VCO is not yet locked to the reference, the instantaneous frequencies of the two PD

inputs are different, and the phase difference of the two inputs at the PD varies rapidly over a range much greater than $\pm 2\pi$ radians. Because the gain of the PD varies linearly with phase up to $\pm 2\pi$, the gain of a conventional PD cycles from high gain, when the phase difference approaches a multiple of 2π , to low gain, when the phase difference is slightly larger than a multiple of 0 radians. The output current from the charge pump cycles from maximum to minimum, even though the VCO has not yet reached its final frequency.

The charge on the loop filter small capacitor may actually discharge slightly during the low gain portion of the cycle. This can make the VCO frequency reverse temporarily during locking. This phenomenon is known as cycle slipping. Cycle slipping causes the pull-in rate during the locking phase to vary cyclically. Cycle slipping increases the time to lock to a value greater than that predicted by normal small signal Laplace transform analysis.

The HMC832 PD features an ability to reduce cycle slipping during acquisition. The cycle slip prevention (CSP) feature increases the PD gain during large phase errors. The specific phase error that triggers the momentary increase in PD gain is set via Register 0x0B[8:7].

Frequency Tuning

The HMC832 VCO subsystem always operates in fundamental frequency of operation (1500 MHz to 3000 MHz). The HMC832 generates frequencies below its fundamental frequency (25 MHz to 1500 MHz) by tuning to the appropriate fundamental frequency and selecting the appropriate output divider setting (divide by 2/4/6/ ... 60/62) in VCO_REG 0x02[5:0].

The HMC832 automatically controls frequency tuning in the fundamental band of operation, for more information see the VCO Autocalibration section.

To tune to frequencies below the fundamental frequency range (<1500 MHz) it is required to tune the HMC832 to the appropriate fundamental frequency, then select the appropriate output divider setting (divide by 2/4/6/ ... 60/62) in VCO_REG 0x02[5:0].

Integer Mode

The HMC832 is capable of operating in integer mode. For integer mode, set the following registers:

- Disable the fractional modulator, Register 0x06[11] = 0
- Bypass the modulator circuit, Register 0x06[7] = 1

In integer mode, the VCO step size is fixed to that of the PD frequency. Integer mode typically has a 3 dB lower phase noise than fractional mode for a given PD operating frequency. Integer mode, however, often requires a lower PD frequency to meet step size requirements. The fractional mode advantage is that higher PD frequencies can be used; therefore, lower phase noise can often be realized in fractional mode. Disable charge pump offset when in integer mode.

Integer Frequency Tuning

In integer mode the digital Δ - Σ modulator is shut off and the N divider (Register 0x03) may be programmed to any integer value in the range of 16 to $2^{19} - 1$. To run in integer mode, configure Register 0x06 (as described in the Integer Mode section), then program the integer portion of the frequency as explained by Equation 12, ignoring the fractional part.

1. Disable the fractional modulator, Register 0x06[11] = 0
2. Bypass the Δ - Σ modulator Register 0x06[7] = 1
3. To tune to frequencies (<1500 MHz), select the appropriate output divider value VCO_REG 0x02[5:0].

Writing to VCO subsystem registers (VCO_REG 0x02[5:0] and VCO_REG 0x03[0] in this case) is accomplished indirectly through PLL Register 5 (Register 0x05). More information on communicating with the VCO subsystem through PLL Register 0x05 is available in the VCO Serial Port Interface (VSPI) section.

Fractional Mode

The HMC832 is placed in fractional mode by setting the following registers:

- Enable the fractional modulator, Register 0x06[11] = 1.
- Connect the Δ - Σ modulator in circuit, Register 0x06[7] = 0.

Fractional Frequency Tuning

This is a generic example, with the goal of explaining how to program the output frequency. Actual variables are dependant upon the reference in use.

The HMC832 in fractional mode can achieve frequencies at fractional multiples of the reference. The frequency of the HMC832, f_{VCO} , is given by

$$f_{VCO} = \frac{f_{XTAL}}{R}(N_{INT} + N_{FRAC}) = f_{INT} + f_{FRAC} \quad (12)$$

$$f_{OUT} = f_{VCO}/k \quad (13)$$

where:

f_{OUT} is the output frequency after any potential dividers.

k is 1 for fundamental, or $k = 2, 4, 6, \dots 58, 60, 62$ depending on the selected output divider value (Register 0x05[5:0] indirectly to VCO_REG 0x02[5:0]).

N_{INT} is the integer division ratio, Register 0x03, an integer number between 20 and 524,284.

N_{FRAC} is the fractional part, from 0.0 to 0.99999..., $N_{FRAC} = \text{Register } 0x04/2^{24}$.

R is the reference path division ratio, Register 0x02.

f_{XTAL} is the frequency of the reference oscillator input.

f_{PD} is the PD operating frequency, f_{XTAL}/R .

For example:

$$f_{OUT} = 1402.5 \text{ MHz}$$

$$k = 2$$

$$f_{VCO} = 2,805 \text{ MHz}$$

$$f_{XTAL} = 50 \text{ MHz}$$

$$R = 1$$

$$f_{PD} = 50 \text{ MHz}$$

$$N_{INT} = 56$$

$$N_{FRAC} = 0.1$$

$$\text{Register } 0x04 = \text{round}(0.1 \times 2^{24}) = \text{round}(1,677,721.6) = 1,677,722.$$

$$f_{VCO} = \frac{50 \times 10^6}{1} \left(56 + \frac{1,677,722}{2^{24}} \right) = 2805 \text{ MHz} + 1.192 \text{ Hz error} \quad (14)$$

$$f_{OUT} = \frac{f_{VCO}}{2} = 1402.5 \text{ MHz} + 0.596 \text{ Hz error} \quad (15)$$

In this example, the output frequency of 1402.5 MHz is achieved by programming the 19-bit binary value of 56d = 0x38 into the INTG_REG bit in Register 0x03, and the 24-bit binary value of 1677722d = 0x19999A into the FRAC bit in Register 0x04. The 0.596 Hz quantization error can be eliminated using the exact frequency mode, if required. In this example, the output fundamental is divided by 2. Specific control of the output divider is required. See the VCO Subsystem Register Map section and description for details.

Exact Frequency Tuning

Due to quantization effects, the absolute frequency precision of a fractional PLL is normally limited by the number of bits in the fractional modulator. For example, a 24-bit fractional modulator has frequency resolution set by the phase detector (PD) comparison rate divided by 2^{24} . The value 2^{24} in the denominator is sometimes referred to as the modulus. Analog Devices PLLs use a fixed modulus, which is a binary number. In some types of fractional PLLs the modulus is variable, allowing exact frequency steps to be achieved with decimal step sizes. Unfortunately, small steps using small modulus values result in large spurious outputs at multiples of the modulus period (channel step size). For this reason, Analog Devices PLLs use a large fixed modulus. Normally, the step size is set by the size of the fixed modulus. In the case of a 50 MHz PD rate, a modulus of 2^{24} would result in a 2.98 Hz step resolution, or 0.0596 ppm. In some applications it is necessary to have exact frequency steps, and even an error of 3 Hz cannot be tolerated.

Fractional PLLs are able to generate exact frequencies (with zero frequency error) if N can be exactly represented in binary (for example, N = 50.0, 50.5, 50.25, 50.75, and so forth). Note that, some common frequencies cannot be exactly represented. For example, $N_{FRAC} = 0.1 = 1/10$ must be approximated as $\text{round}((0.1 \times 2^{24})/2^{24}) \approx 0.100000024$. At $f_{PD} = 50 \text{ MHz}$, this

translates to a 1.2 Hz error. The exact frequency mode of the HMC832 addresses this issue and can eliminate quantization error by programming the channel step size to $f_{PD}/10$ in Register 0x0C to 10 (in this example). More generally, this feature can be used whenever the desired frequency, f_{VCO} , can be exactly represented on a step plan where there are an integer number of steps ($<2^{14}$) across integer-N boundaries. Mathematically, this situation is satisfied if

$$f_{VCOk} \bmod(f_{GCD}) = 0$$

$$\text{where } f_{GCD} = GCD(f_{VCO1}, f_{PD}) \text{ and } f_{GCD} \geq \left(\frac{f_{PD}}{2^{14}}\right) \quad (16)$$

where:

GCD means greatest common divisor.

f_{PD} = frequency of the phase detector.

f_{VCOk} is the channel step frequency where $0 < k < 2^{14}-1$, as shown in Figure 46.

Some fractional PLLs are able to achieve these exact frequencies by adjusting (shortening) the length of the phase accumulator

(the denominator or the modulus of the Δ - Σ modulator) so that the Δ - Σ modulator phase accumulator repeats at an exact period related to the interval frequency ($f_{VCOk} - f_{VCO(k-1)}$) in Figure 46. Consequently, the shortened accumulator results in more frequent repeating patterns and as a result often leads to spurious emissions at multiples of the repeating pattern period, or at harmonic frequencies of $f_{VCOk} - f_{VCO(k-1)}$. For example, in some applications, these intervals might represent the spacing between radio channels, with the spurious occurring at multiples of the channel spacing.

In comparison, the Analog Devices method is able to generate exact frequencies between adjacent integer-N boundaries while still using the full 24-bit phase accumulator modulus, thus achieving exact frequency steps with a high phase detector comparison rate, which allows Analog Devices PLLs to maintain excellent phase noise and spurious performance in the exact frequency mode.

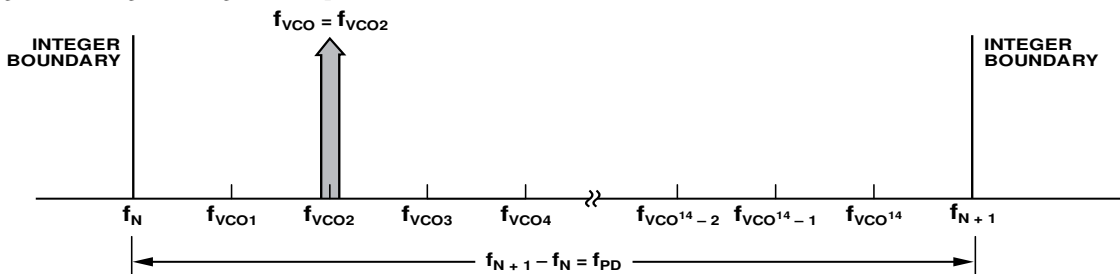

Figure 46. Exact Frequency Tuning

12827-051

Using Exact Frequency Mode

If the constraint in Equation 16 is satisfied, the HMC832 is able to generate signals with zero frequency error at the desired VCO frequency. Exact frequency mode can be reconfigured for each target frequency, or be setup for a fixed f_{GCD} that applies to all channels.

Configuring Exact Frequency Mode for a Particular Frequency

1. Calculate and program the integer register setting

$$\text{Register } 0x03 = N_{INT} = \text{floor}(f_{VCO}/f_{PD})$$

where the *floor* function is the rounding down to the nearest integer.

2. Then calculate the integer boundary frequency

$$f_N = N_{INT} \times f_{PD}$$

3. Calculate and program the exact frequency register value

$$\text{Register } 0x0C = f_{PD}/f_{GCD}$$

where $f_{GCD} = \text{GCD}(f_{VCO}, f_{PD})$.

4. Calculate and program the fractional register setting

$$\text{Register } 0x04 \ N_{FRAC} = \text{ceil}\left(\frac{2^{24}(f_{VCOk} - f_N)}{f_{PD}}\right)$$

where *ceil* is the ceiling function meaning round up to the nearest integer.

Example: to configure the HMC832 for exact frequency mode at $f_{VCO} = 2800.2$ MHz, where the PD rate (f_{PD}) = 61.44 MHz, proceed as follows:

1. Check Equation 16 to confirm that the exact frequency mode for this f_{VCO} is possible.

$$f_{GCD} = \text{GCD}(f_{VCO}, f_{PD}) \text{ and } f_{GCD} \geq \left(\frac{f_{PD}}{2^{14}}\right)$$

$$f_{GCD} = \text{GCD}(2800.2 \times 10^6, 61.44 \times 10^6) = 120 \times 10^3 > \frac{61.44 \times 10^6}{2^{14}} = 3750$$

Because Equation 16 is satisfied, the HMC832 can be configured for exact frequency mode at $f_{VCO} = 2800.2$ MHz by continuing with the remaining steps.

2. Calculate N_{INT}

$$N_{INT} = \text{Register } 0x03 =$$

$$\text{floor}\left(\frac{f_{VCO1}}{f_{PD}}\right) = \text{floor}\left(\frac{2800.2 \times 10^6}{61.44 \times 10^6}\right) = 45d = 0x2D$$

3. Calculate the value for Register 0x0C

$$\text{Register } 0x0C =$$

$$\frac{f_{PD}}{\text{GCD}((f_{VCOk+1} - f_{VCOk}), f_{PD})} = \frac{61.44 \times 10^6}{\text{GCD}(100 \times 10^3, 61.44 \times 10^6)} = \frac{61.44 \times 10^6}{20000} = 3072d = 0x00$$

4. To program Register 0x04, the closest integer-N boundary frequency (f_N) that is less than the desired VCO frequency (f_{VCO}) must be calculated: $f_N = f_{PD} \times N_{INT}$. Using the current example

$$f_N = f_{PD} \times N_{INT} = 45 \times 61.44 \times 10^6 = 2764.8 \text{ MHz, then}$$

$$\text{Register } 0x04 =$$

$$\text{ceil}\left(\frac{2^{24}(f_{VCO} - f_N)}{f_{PD}}\right) = \text{ceil}\left(\frac{2^{24}(2800.2 \times 10^6 - 2764.8 \times 10^6)}{61.44 \times 10^6}\right) = 9666560d = 0x938000$$

Exact Frequency Channel Mode

When multiple, equally spaced, exact frequency channels are needed that fall within the same interval (that is, $f_N \leq f_{VCOk} < f_{N+1}$) where f_{VCOk} is shown in Figure 46 and $1 \leq k \leq 2^{14}$, it is possible to maintain the same integer-N (Register 0x03) and exact frequency register (Register 0x0C) settings and only update the fractional register (Register 0x04) setting. The exact frequency channel mode is possible when Equation 16 is satisfied for at least two equally spaced adjacent frequency channels, that is, the channel step size.

To configure the HMC832 for exact frequency channel mode, initially and only at the beginning, the integer (Register 0x03) and exact frequency (Register 0x0C) registers need to be programmed for the smallest f_{VCO} frequency (f_{VCO1} in Figure 46), as follows:

1. Calculate and program the integer register setting Register 0x03 = $N_{INT} = \text{floor}(f_{VCO1}/f_{PD})$, where f_{VCO1} is shown in Figure 46 and corresponds to the minimum channel VCO frequency. Then, the lower integer boundary frequency is given by $f_N = N_{INT} \times f_{PD}$.
2. Calculate and program the exact frequency register value Register 0x0C = f_{PD}/f_{GCD} , where $f_{GCD} = \text{GCD}((f_{VCOk+1} - f_{VCOk}), f_{PD})$ = greatest common divisor of the desired equidistant channel spacing and the PD frequency ($(f_{VCOk+1} - f_{VCOk})$ and f_{PD}).

To switch between various equally spaced intervals (channels) only the fractional register (Register 0x04) needs to be programmed to the desired VCO channel frequency (f_{VCOk}) in the following manner:

$$\text{Register } 0x04 = N_{FRAC} = \text{ceil}\left(\frac{2^{24}(f_{VCOk} - f_N)}{f_{PD}}\right)$$

where $f_N = \text{floor}(f_{VCO1}/f_{PD})$, and f_{VCO1} , as shown in Figure 46, represents the smallest channel VCO frequency that is greater than f_N .

Example: to configure the HMC832 for the exact frequency mode for equally spaced intervals of 100 kHz, where the first channel (Channel 1) = $f_{VCO1} = 2800.200$ MHz and the PD rate (f_{PD}) = 61.44 MHz, proceed as follows:

1. Check that the exact frequency mode for this $f_{VCO1} = 2800.2$ MHz (Channel 1) and $f_{VCO2} = 2800.2$ MHz + 100 kHz = 2800.3 MHz (Channel 2) is possible.

$$f_{GCD1} = \text{GCD}(f_{VCO1}, f_{PD}) \text{ and}$$

$$f_{GCD1} \geq \left(\frac{f_{PD}}{2^{14}}\right) \text{ and } f_{GCD2} = \text{GCD}(f_{VCO2}, f_{PD}) \quad (17)$$

$$\text{and } f_{GCD2} \geq \left(\frac{f_{PD}}{2^{14}}\right)$$

$$f_{GCD1} = \text{GCD}(2800.2 \times 10^6, 61.44 \times 10^6) =$$

$$120 \times 10^3 > \frac{61.44 \times 10^6}{2^{14}} = 3750$$

$$f_{GCD2} = \text{GCD}(2800.3 \times 10^6, 61.44 \times 10^6) =$$

$$20 \times 10^3 > \frac{61.44 \times 10^6}{2^{14}} = 3750$$

2. If Equation 16 is satisfied for at least two of the equally spaced interval (channel) frequencies f_{VCO1} , f_{VCO2} , f_{VCO3} , ... f_{VCON} , as it is in Equation 17, HMC832 exact frequency channel mode is possible for all desired channel frequencies, and can be configured as follows:

$$\text{Register } 0x03 =$$

$$\text{floor}\left(\frac{f_{VCO1}}{f_{PD}}\right) = \text{floor}\left(\frac{2800.2 \times 10^6}{61.44 \times 10^6}\right) = 45d = 0x2D$$

$$\text{Register } 0x0C =$$

$$\frac{f_{PD}}{\text{GCD}((f_{VCOk+1} - f_{VCOk}), f_{PD})} = \frac{61.44 \times 10^6}{\text{GCD}(100 \times 10^3, 61.44 \times 10^6)} =$$

$$\frac{61.44 \times 10^6}{20000} = 3072d = 0xC00$$

where $(f_{VCOk+1} - f_{VCOk})$ is the desired channel spacing (100 kHz in this example).

3. To program Register 0x04, the closest integer-N boundary frequency, f_N , that is less than the smallest channel VCO frequency, f_{VCO1} , must be calculated ($f_N = \text{floor}(f_{VCO1}/f_{PD})$). Using the current example:

$$f_N = f_{PD} \times \text{floor}\left(\frac{2800.2 \times 10^6}{61.44 \times 10^6}\right) =$$

$$45 \times 61.44 \times 10^6 = 2764.8 \text{ MHz}$$

Then, for Channel 1,

$$\text{Register } 0x04 = \text{ceil}\left(\frac{2^{24}(f_{VCO1} - f_N)}{f_{PD}}\right),$$

where $f_{VCO1} = 2800.2$ MHz.

$$= \text{ceil}\left(\frac{2^{24}(2800.2 \times 10^6 - 2764.8 \times 10^6)}{61.44 \times 10^6}\right) = 9666560d = 0x938000$$

4. To change from Channel 1 ($f_{VCO1} = 2800.2$ MHz) to Channel 2 ($f_{VCO2} = 2800.3$ MHz), only Register 0x04 needs to be programmed, as long as all of the desired exact frequencies, f_{VCOk} (Figure 46), fall between the same integer-N boundaries ($f_N < f_{VCOk} < f_{N+1}$). In that case,

$$\text{Register } 0x04 =$$

$$\text{ceil}\left(\frac{2^{24}(2800.3 \times 10^6 - 2764.8 \times 10^6)}{61.44 \times 10^6}\right) =$$

$$9693867d = 0x93EAAB, \text{ and so on.}$$

Seed Register

The start phase of the fractional modulator digital phase accumulator (DPA) can be set to one of four possible default values via the seed register, Register 0x06[1:0]. The HMC832 automatically reloads the start phase (seed value) into the DPA every time a new fractional frequency is selected. Certain zero or binary seed values may cause spurious energy correlation at specific frequencies. For most cases a random (not zero and not binary) start seed is recommended (Register 0x06[1:0] = 2).

SOFT RESET AND POWER-ON RESET

The HMC832 features a hardware power-on reset (POR). All chip registers are reset to default states approximately 250 μ s after power up.

The PLL subsystem SPI registers can also be soft reset by an SPI write to Register 0x00. Note that the soft reset does not clear the SPI mode of operation referred to in the Serial Port section. Note that the VCO subsystem is not affected by the PLL soft reset; the VCO subsystem registers can only be reset by removing the power supply.

If external power supplies or regulators have rise times slower than 250 μ s, then it is advised to write to the SPI reset register (Register 0x00[5] = 1) immediately after power up, before any other SPI activity. This write procedure ensures starting from a known state.

POWER-DOWN MODE

Note that the VCO subsystem is not affected by the CEN or soft reset. Therefore, device power-down is a two step process.

1. Power down the VCO by writing 0 to VCO Register 1 via Register 0x05 .
2. Power-down the PLL by pulling the CEN pin (Pin 17) low (assuming there are no SPI overrides (Register 0x01[0] = 1)). Pulling the CEN pin low disables all analog functions and internal clocks. Current consumption typically drops below 10 μ A in the power-down state. The serial port still responds to normal communication in power-down mode.

It is possible to ignore the CEN pin by setting Register 0x01[0] = 0. Control of the power-down mode then comes from the serial port register, Register 0x01[1].

It is also possible to leave various blocks turned on when in power-down (see Register 0x01), as listed in Table 10.

Table 10. Bit and Block Assignments for Register 0x01

Bit Assignment	Block Assignment
Bit 2	Internal bias reference sources
Bit 3	PD block
Bit 4	CP block
Bit 5	Reference path buffer
Bit 6	VCO path buffer
Bit 7	Digital I/O test pads

To mute the output but leave the PLL and VCO locked, see the VCO Output Mute Function section.

GENERAL-PURPOSE OUTPUT (GPO) PIN

The PLL shares the LD_SDO (lock detect/serial data output) pin to perform various functions. Although the pin is most commonly used to read back registers from the chip via the SPI, it is also capable of exporting a variety of signals and real-time test waveforms (including lock detect). It is driven by a tristate CMOS driver with $\sim 200 \Omega$ R_{OUT} . It has logic associated with it to dynamically select whether the driver is enabled, and to decide which data to export from the chip.

In its default configuration, after power-on reset, the output driver is disabled, and only drives during appropriately addressed SPI reads. This allows it to share the output with other devices on the same bus.

The pin driver is enabled if the chip is addressed; that is, the last three bits of SPI cycle = 000b before the rising edge of SEN. If SEN rises before SCK has clocked in an invalid (non zero) chip address, the HMC832 starts to drive the bus.

To monitor any of the GPO signals, including lock detect, set Register 0x0F[7] = 1 to keep the SDO driver always on. This stops the LDO driver from tristating and means that the SDO line cannot be shared with other devices.

The HMC832 naturally switches away from the GPO data and exports the SDO during an SPI read. To prevent this automatic data selection, and always select the GPO signal, set Bit 6 of

Register 0x0F to 1 to prevent automux of the SDO. The phase noise performance at this output is poor and uncharacterized. Also, the GPO output should not be toggling during normal operation because it may degrade the spectral performance.

Note that there are additional controls available, which may be helpful when sharing the bus with other devices.

- To disable the driver completely, set Register 0x08[5] = 0 (it takes precedence over all else).
- To disable either the pull-up or pull-down sections of the driver, Register 0x0F[8] = 1 or Register 0x0F[9] = 1, respectively.

Example scenarios are listed in Table 11. The signals that are available on the GPO are selected by changing the GPO Select Register 0x0F[4:0].

Table 11. Driver Scenarios

Scenario	Action
Drive SDO During Reads, Tristate Otherwise (Allow Bus Sharing)	None required
Drive SDO During Reads, Lock Detect Otherwise	Set GPO Select Register 0x0F[4:0] = 00001b (default) Set Register 0x0F[7] = 1, prevent GPO driver disable
Always Drive Lock Detect	Set Register 0x0F[6] = 1, prevent automux of SDO Set the GPO Select Register 0x0F[4:0] = 00001 (default) Set Register 0x0F[7] = 1, prevent GPO driver disable

CHIP IDENTIFICATION

PLL subsystem version information may be read by reading the content of read only register, chip_ID in Register 0x00. It is not possible to read the VCO subsystem version.

SERIAL PORT

The SPI protocol has the following general features:

- 3-bit chip address, can address up to eight devices connected to the serial bus.
- Wide compatibility with multiple protocols from multiple vendors.
- Simultaneous write/read during the SPI cycle.
- 5-bit address space.
- 3-wire for write only capability, 4-wire for read/write capability.

Typical serial port operation can be run with SCLK at speeds up to 50 MHz.

Serial Port Initialization at Power-Up

At power-up, it is required that both SEN and SCK lines are initially held low, and that the first rising edge occurs on the SCK line before any rising edges occur on the SEN line.

If the first rising edge occurs on the SEN line before it does on the SCK line the HMC832LP6GE SPI interface does not function. In that case, it is necessary to cycle the power to the off and on, and repeat the previous recommended sequence (hold both signals low at power-up and ensure that the first rising edge occurs on the SCK line).

Serial Port Write Operation

SPI write specifications are listed in the Table 2 in the SPI Write Timing Characteristics section and a typical write cycle is shown in Figure 47. The SPI write operation is as follows:

1. The master (host) places 24-bit data, D23:D0, MSB first, on SDI on the first 24 falling edges of SCLK.
2. The slave (HMC832) shifts in data on SDI on the first 24 rising edges of SCLK.

3. The master places a 5-bit register address to be written to, R4:R0, MSB first, on the next five falling edges of SCLK (25th to 29th falling edges).
4. The slave shifts the register bits on the next five rising edges of SCLK (25th to 29th rising edges).
5. The master places 3-bit chip address, A2:A0, MSB first, on the next three falling edges of SCLK (30th to 32nd falling edges). Analog Devices reserves Chip Address A2 to Chip Address A0 = 000 for all RF PLLs with integrated VCOs.
6. The slave shifts the chip address bits on the next three rising edges of SCLK (30th to 32nd rising edges).
7. The master asserts SEN after the 32nd rising edge of SCLK.
8. The slave registers the SDI data on the rising edge of SEN.

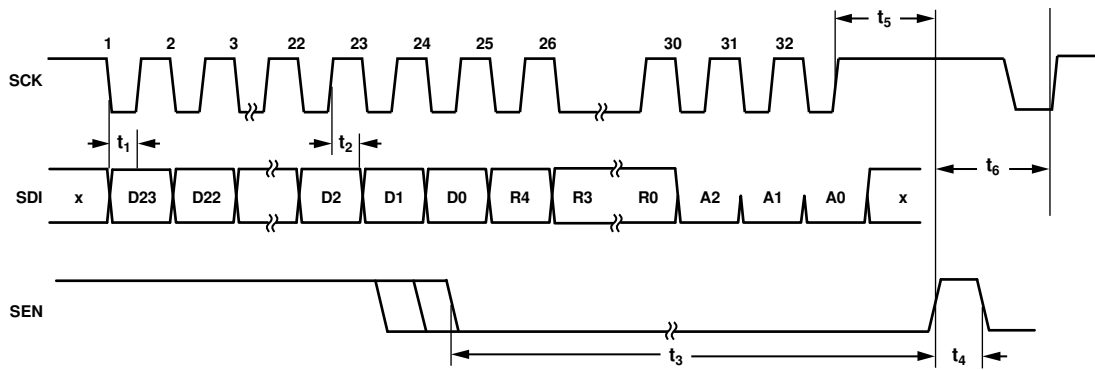

Figure 47. Serial Port Timing Diagram, Write

12827-062

Serial Port Read Operation

In general, the LD_SDO line is always active during the write cycle. During any SPI cycle, LD_SDO contains the data from the current address written in Register 0x0[4:0]. If Register 0x0[4:0] is not changed, the same data is always present on LD_SDO during a SPI cycle.

If a read is required from a specific address, it is necessary to write the required address to Register 0x0[4:0] in the first SPI cycle, then in the next SPI cycle, the desired data becomes available on LD_SDO. A typical read cycle is shown in Figure 48.

An example of the two cycle procedure to read from any random address is as follows:

1. The master (host), on the first 24 falling edges of SCLK places 24-bit data, D23:D0, MSB first, on SDI as shown in Figure 48. Set D23:D5 to zero. D4:D0 = address of the register to be read on the next cycle.
2. The slave (HMC832) shifts in data on SDI on the first 24 rising edges of SCK.
3. The master places the 5-bit register address, R4:R0, (the read address register), MSB first, on the next five falling edges of SCK (25th to 29th falling edges). R4:R0 = 00000.
4. The slave shifts the register bits on the next five rising edges of SCK (25th to 29th rising edges).
5. The master places the 3-bit chip address, A2:A0, MSB first, on the next three falling edges of SCK (30th to 32nd falling edges). The chip address is always 000b.
6. The slave shifts the chip address bits on the next three rising edges of SCK (30th to 32nd rising edges).
7. The master asserts SEN after the 32nd rising edge of SCK.
8. The slave registers the SDI data on the rising edge of SEN.
9. The master clears SEN to complete the the address transfer of the two part read cycle.
10. If a write data to the chip is not needed at the same time as the second cycle occurs, then it is recommended to simply rewrite the same contents on SDI to Register 0x00 on the readback portion of the cycle.
11. The master places the same SDI data as the previous cycle on the next 32 falling edges of SCK.
12. The slave (HMC832) shifts the SDI data on the next 32 rising edges of SCK.
13. The slave places the desired read data (that is, data from the address specified in Register 0x00[4:0] of the first cycle) on LD_SDO, which automatically switches to SDO mode from LD mode, disabling the LD output.
14. The master asserts SEN after the 32nd rising edge of SCK to complete the cycle and revert back to lock detect on LD_SDO.

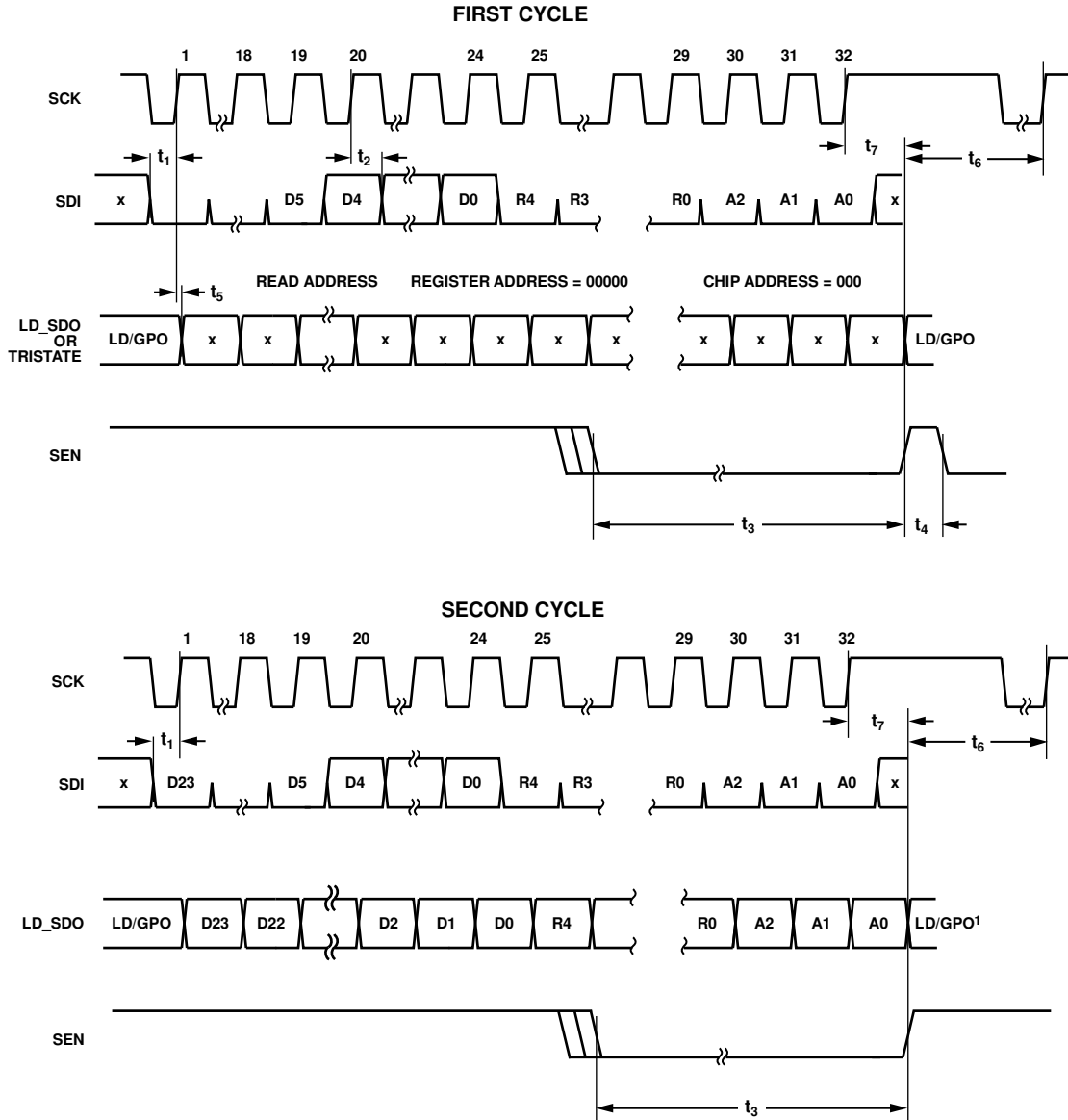

¹FOR MORE INFORMATION ON USING THE GPO PIN WHILE IN SPI OPEN MODE PLEASE SEE SERIAL PORT SECTION.

Figure 48. Serial Port Timing Diagram, Read

128827-053

APPLICATIONS INFORMATION

Large bandwidth (25 MHz to 3000 MHz), industry leading phase noise and spurious performance, excellent noise floor (-160 dBc/Hz), coupled with a high level of integration make the HMC832 ideal for a variety of applications; as an RF or IF stage local oscillator (LO).

Using the HMC832 with a tunable reference, as shown in Figure 51, it is possible to drastically improve spurious emissions performance across all frequencies.

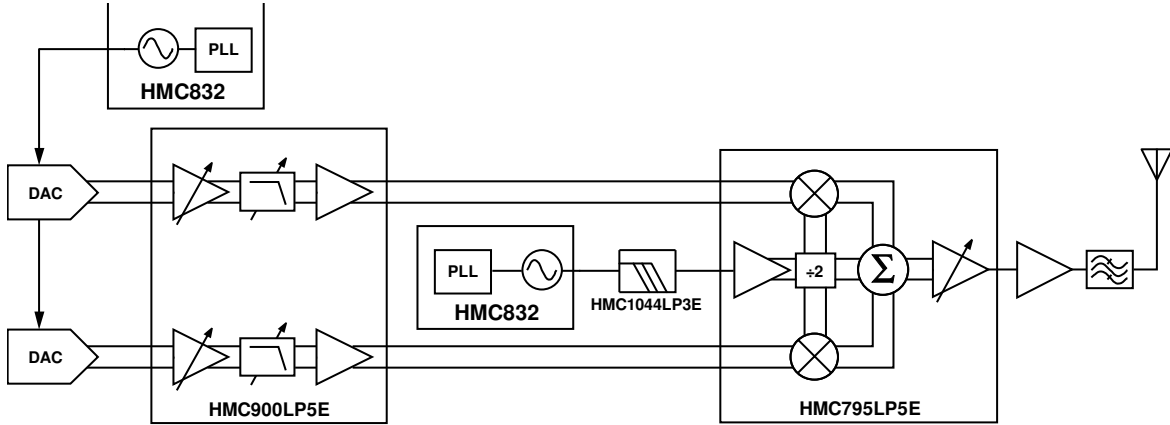

Figure 49. HMC832 in a Typical Transmit Chain

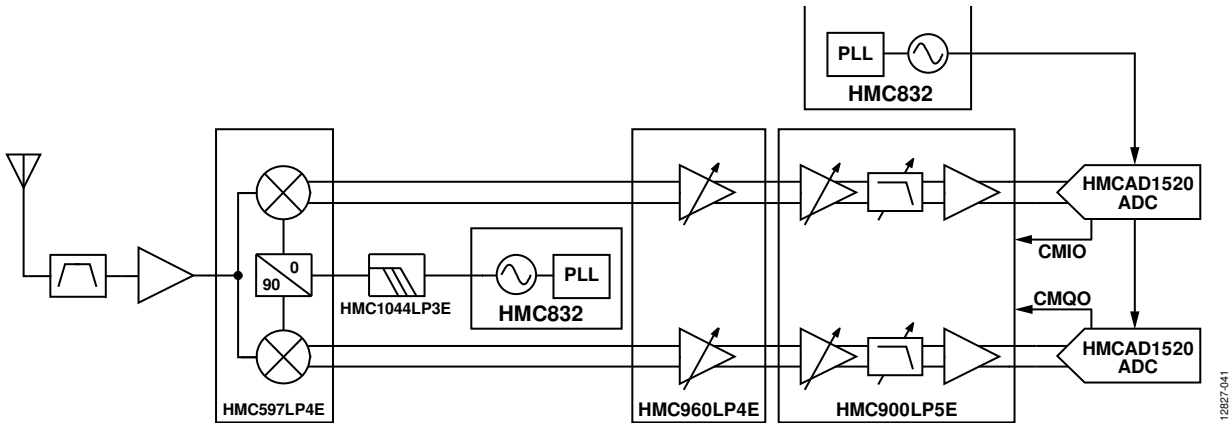

Figure 50. HMC832 in a Typical Receive Chain

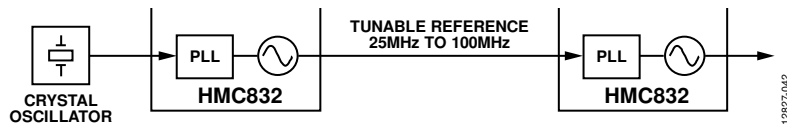

Figure 51. HMC832 Used as a Tunable Reference for HMC832

POWER SUPPLY

The HMC832 is a high performance, low noise device. In some cases, phase noise and spurious performance may be degraded by noisy power supplies. To achieve maximum performance and ensure that power supply noise does not degrade the performance of the HMC832 it is recommended to use the Analog Devices low noise, high power supply rejection ratio (PSRR) regulator, the HMC1060LP3E. Using the HMC1060LP3E lowers the design risk and cost, and ensures that the performance shown in the Typical Performance Characteristics section can be achieved.

PROGRAMMABLE PERFORMANCE TECHNOLOGY

For low power applications that do not require maximum noise floor performance, the HMC832 features the ability to reduce current consumption by 50 mA (power consumption by 165 mW) at the cost of decreasing phase noise floor performance by ~5 dB. High performance is enabled by writing VCO_REG 0x03[1:0] = 3d, and it is disabled (low current consumption mode enabled) by writing VCO_REG 0x03[1:0] = 1d. High performance mode improves noise floor performance at the cost of increased current consumption. Resulting current consumption and phase noise floor performance are shown in Figure 33 and Figure 36.

LOOP FILTER AND FREQUENCY CHANGES

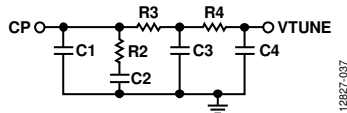

Figure 52. Loop Filter Design

All PLLs with integrated VCOs exhibit integer boundary spurs at harmonics of the reference frequency. As seen in Figure 18, the plot shows the worst case spurious scenario where the harmonic of the reference frequency (50 MHz) is within the loop filter bandwidth of the fundamental frequency of the HMC832.

The tunable reference changes the reference frequency from 50 MHz in Figure 18 to 47.5 MHz in Figure 16 to distance the harmonic of the reference frequency (spurious emissions) away from the fundamental output frequency of the HMC832 so that

it is filtered by the loop filter. The internal HMC832 setup and divide ratios are changed in the opposite direction accordingly so that the HMC832 generates identical output frequency as shown in Figure 18, without the spurious emissions inside the loop bandwidth. Using these same procedures, in Figure 19, the graph is generated by observing and plotting the magnitude of the largest spur only, at any offset, at each output frequency, while using a fixed 50 MHz reference and a tunable 47.5 MHz reference.

The HMC832 features an internal autocalibration process that seamlessly calibrates the HMC832 when a frequency change is executed (see Figure 27 and Figure 30). Typical frequency settling time that can be expected after any frequency change (writes to Register 0x03 or Register 0x04) is shown in Figure 27 with autocalibration enabled (Register 0x0A[11] = 0). A frequency hop of 5 MHz is shown in Figure 27; however the settling time is independent of the size of the frequency change. Any size frequency hop has a similar settling time with autocalibration enabled. Figure 32 shows the typical tuning voltage after calibration where once the HMC832 is calibrated at any temperature, the calibration setting holds across the entire operating range of the HMC832 (-40°C to +85°C). Figure 32 shows that the tuning voltage is maintained within a narrow operating range for worst case scenarios where calibration was executed at one temperature extreme and the device is operating at the other extreme.

For applications that require fast frequency changes, the HMC832 supports manual calibration that enables faster settling times (see Figure 28 and Figure 31). Manual calibration needs to be executed only once for each individual HMC832, at any temperature, and is valid across all temperature operating ranges of the HMC832. More information about manual calibration is available in the Manual VCO Calibration for Fast Frequency Hopping section. A Frequency hop of 5 MHz is shown in Figure 28 and Figure 31; however, the settling time is independent of the size of the frequency change. Any size frequency hop has a similar settling time with autocalibration disabled (Register 0x0A[11] = 1).

Table 12. Loop Filter Designs Used in Typical Performance Characteristics Graphs

Loop Filter Type	Loop Filter BW (kHz)	Loop Filter Phase Margin	C1 (pF)	C2 (nF)	C3 (pF)	C4 (pF)	R2 (Ω)	R3 (Ω)	R4 (Ω)	Loop Filter Design
Type 1 ¹	127	61°	390	10	82	82	750	300	300	See Figure 52
Type 2 ²	75	61°	270	27	200	390	430	390	390	
Type 3 ³	214	71°	56	1.8	NA	NA	2200	0	0	

¹ Loop Filter Type 1 is for best integrated phase noise. Loop filter bandwidth is designed for 50 MHz PD frequency, CP = 1.6 mA at 2.2 GHz output in fractional mode.

² Loop Filter Type 2 is suggested to use for best far out phase noise. Loop filter BW is designed for 50 MHz PD frequency, CP = 1.6 mA at 2.2 GHz output in fractional mode.

³ Loop Filter Type 3 is suggested to use for best integrated phase noise at integer mode. Loop filter bandwidth is designed for 50 MHz PD frequency, CP = 2.5 mA at 3 GHz output in integer mode.

RF PROGRAMMABLE OUTPUT RETURN LOSS

The HMC832 features programmable RF output return loss (VCO_REG 0x03[5]) and 12 dB of programmable gain (VCO_REG 0x07[3:0]), as shown in Figure 26 and Figure 25. Maximum output power is achieved with a high return loss setting (VCO_REG 0x03[5] = 0), as shown in Figure 22. Setting VCO_REG 0x03[5] = 1 improves return loss for applications that require it at the cost of reduced RF output power (see Figure 22).

MUTE MODE

The HMC832 features a configurable mute mode, along with the ability to independently turn off outputs on both RF_N and RF_P output pins. Figure 35 shows isolation measured at the output when the mute mode is on (VCO_REG 0x03[8:7] = 3d), and when the mute mode is off (VCO_REG 0x03[8:7] = 1d), with either both outputs disabled (VCO_REG 0x03[3:2] = 0) or one output enabled and the other disabled (VCO_REG 0x03[3:2] = 1d).

PLL REGISTER MAP

ID, READ ADDRESS, AND RST REGISTERS

The ID register is read only, the read address/RST strobe register is write only, and the RST register is read/write.

Table 13. Register 0x00, ID Register (Read Only)

Bits	Type	Name	Width	Default	Description
23:0	R	CHIP_ID	24	A7975	HMC832LP6GE chip ID

Table 14. Register 0x00, Read Address/RST Strobe Register (Write Only)

Bits	Type	Name	Width	Default ¹	Description
4:0	W	Read address	5	N/A	Read address for next cycle, open mode only. This is a write only register.
5	W	Soft reset	1	N/A	Soft reset for both SPI modes (set to 0 for proper operation).
23:6	W	Not defined	18	N/A	Not defined (set to 0 for proper operation).

¹ N/A means not applicable.

Table 15. Register 0x01, RST Register (Default 0x000002)

Bits	Type	Name	Width	Default	Description
0	R/W	RST_CHIPEN_PIN_SELECT	1	0	1 = take PLL enable via CEN pin, see the Power-Down Mode section 0 = take PLL enable via SPI (RST_CHIPEN_FROM_SPI) Register 0x01[1]
1	R/W	RST_CHIPEN_FROM_SPI	1	1	PLL enable bit of the SPI
9:2	R/W	Reserved	8	0	Reserved

REFERENCE DIVIDER, INTEGER, AND FRACTIONAL FREQUENCY REGISTERS

Table 16. Register 0x02, REFDIV Register (Default 0x000001)

Bits	Type	Name	Width	Default	Description
13:0	R/W	RDIV	14	1	Reference divider R value (see Equation 12). Using the divider requires the Analog EN Register 0x08[3] = 1 and divider, minimum = 1d, maximum = 16,383d.

Table 17. Register 0x03, Frequency Register, Integer Part (Default 0x000019)

Bits	Type	Name	Width	Default	Description
18:0	R/W	INTG_REG	19	25d	Integer divider register. These bits are the VCO divider integer part, used in all modes, see Equation 12. Fractional mode. Maximum $2^{19} - 4 = 0x7FFFC = 524,284d$. Integer mode. Minimum 16d. Maximum $2^{19} - 1 = 0x7FFFF = 524,287d$.

Table 18. Register 0x04, Frequency Register, Fractional Part (Default 0x000000)

Bits	Type	Name	Width	Default	Description
23:0	R/W	FRAC	24	0	VCO divider fractional part (24-bit unsigned), see the Fractional Frequency Tuning section. These bits are used in fractional mode only ($N_{FRAC} = \text{Register } 0x04/2^{24}$). Minimum = 0d; maximum = $2^{24} - 1$.

VCO SPI REGISTER

Register 0x05 is a special register used for indirect addressing of the VCO subsystem. Writes to Register 0x05 are automatically forwarded to the VCO subsystem by the VCO SPI state machine controller.

Register 0x05 is a read/write register. However, Register 0x05 holds only the contents of the last transfer to the VCO subsystem. Therefore, it is not possible to read the full contents of the VCO subsystem. Only the content of the last transfer to the VCO subsystem can be read. Also note special considerations for autocalibration related to Register 0x05.

Table 19. Register 0x05, VCO SPI Register (Default 0x000000)

Bits	Type	Name	Width	Default	Description
2:0	R/W	VCO_ID	3	0	Internal VCO subsystem ID.
6:3	R/W	VCO_REGADDR	4	0	VCO subsystem register address. These bits are for interfacing with the VCO. See the VCO Serial Port Interface (VSPI) section.
15:7	R/W	VCO_DATA	9	0	VCO subsystem data. These bits are for the data to be written to the VCO subsystem.

DELTA-SIGMA CONFIGURATION**Table 20. Register 0x06, Delta-Sigma Configuration Register (Default 0x200B4A)**

Bit	Type	Name	Width	Default	Description
1:0	R/W	Seed	2	2	Selects the seed in fractional mode. Writes to this register are stored in the HMC832 and are loaded into the modulator only when a frequency change is executed and if Register 0x06[8] = 1. 00: 0 seed. 01: LSB seed. 02: 0xB29D08 seed. 03: 0x50F1CD seed.
6:2	R/W	Reserved	5	18d	Reserved.
7	R/W	FRAC_BYPASS	1	0	Bypass fractional mode. In the bypass fractional modulator, output is ignored, but fractional modulator continues to be clocked when FRAC_RST = 1. This bit can be used to test the isolation of the digital fractional modulator from the VCO output in integer mode. 0: use modulator, required for fractional mode 1: bypass modulator, required for integer mode.
10:8	R/W	Initialization	3	3d	Program to 7d.
11	R/W	SD enable	1	1	This bit controls whether autocalibration starts on an integer or a fractional write. 0: disables fractional core, use for integer mode or integer mode with CSP. 1: enables fractional core, required for fractional mode, or integer isolation testing.
20:12	R/W	Reserved	9	0	Reserved.
21	R/W	Automatic clock configuration	1	1	Program to 0.
22	R/W	Reserved	1	0	Reserved.

LOCK DETECT REGISTER**Table 21. Register 0x07, Lock Detect Register (Default 0x00014D)**

Bit	Type	Name	Width	Default	Description
2:0	R/W	LKD_WINCNT_MAX	3	5d	Lock detect window sets the number of consecutive counts of divided VCO that must land inside the lock detect window to declare lock 0: 5 1: 32 2: 96 3: 256 4: 512 5: 2048 6: 8192 7: 65,535
3	R/W	Enable internal lock detect	1	1	See the Serial Port section
5:4	R/W	Reserved	2	0	Reserved
6	R/W	Lock detect window type	1	1	Lock detection window timer selection 1: digital programmable timer 0: analog one shot, nominal 10 ns window
9:7	R/W	LD digital window duration	3	2	Lock detection, digital window duration 0: half cycle 1: one cycle 2: two cycles 3: four cycles 4: eight cycles 5: 16 cycles 6: 32 cycles 7: 64 cycles
11:10	R/W	LD digital timer frequency control	2	0	Lock detect digital timer frequency control, see the Lock Detect section for more information 00: fastest 11: slowest
12	R/W	Reserved	31	0	Reserved
13	R/W	Automatic relock: one try	1	0	1: attempts to relock if lock detect fails for any reason; tries one time only

ANALOG ENABLE (EN) REGISTER**Table 22. Register 0x08, Analog EN Register, (Default 0xC1BEFF)**

Bit	Type	Name	Width	Default	Description
4:0	R/W	Reserved	5	31d	Reserved
5	R/W	GPO_PAD_EN	1	1	0: disables the LD/SDO pin 1: enables GPO port or allows a shared SPI When Bit 5 = 1 and Register 0xF[7] = 1, the LD_SDO pin is always driven, which is required for use of the GPO port When Bit 5 = 1 and Register 0xF[7] = 0, SDO is off when an unmatched chip address is seen on the SPI, allowing a shared SPI with other compatible devices
9:6	R/W	Reserved	4	11d	Reserved
10	R/W	VCO buffer and prescaler bias enable	1	1	VCO buffer and prescaler bias enable
20:11	R/W	Reserved	1	55d	Reserved

Bit	Type	Name	Width	Default	Description
21	R/W	High frequency reference	1	0	Program to 1 for XTAL > 200 MHz
23:22	R/W	Reserved	2	3d	Reserved

CHARGE PUMP REGISTER

Table 23. Register 0x09, Charge Pump Register (Default 0x403264)

Bit	Type	Name	Width	Default	Description
6:0	R/W	CP DN gain	7	100d 0x64	Charge pump DN gain control, 20 μ A per step. Affects fractional phase noise and lock detect settings. 0d = 0 μ A 1d = 20 μ A 2d = 40 μ A ... 127d = 2.54 mA
13:7	R/W	CP UP gain	7	100d 0x64	Charge pump up gain control, 20 μ A per step. Affects fractional phase noise and lock detect settings. 0d = 0 μ A 1d = 20 μ A 2d = 40 μ A ... 127d = 2.54 mA
20:14	R/W	Offset magnitude	7	0	Charge pump offset control, 5 μ A per step. Affects fractional phase noise and lock detect settings. 0d = 0 μ A 1d = 5 μ A 2d = 10 μ A ... 127d = 635 μ A
21	R/W	Offset up enable	1	0	Recommended setting = 1 in fractional mode, 0 otherwise.
22	R/W	Offset DN enable	1	1	Recommended setting = 0.
23	R/W	Reserved	1	0	Reserved.

AUTOCALIBRATION REGISTER

Table 24. Register 0x0A, VCO Autocalibration Configuration Register (Default 0x002205)

Bit	Type	Name	Width	Default	Description
2:0	R/W	VTUNE resolution	3	5	R divider cycles 0: 1 cycle 1: 2 cycles 2: 4 cycles ... 7: 256 cycles
9:3	R/W	Reserved	7	64d	Program 8d
10	R/W	Force curve	1	0	Program 0
11	R/W	Autocalibration disable	1	0	Program 0 for normal operation using VCO autocalibration
12	R/W	No VSPI trigger	1	0	0: normal operation 1: this bit disables the serial transfers to the VCO subsystem (via Register 0x05)

Bit	Type	Name	Width	Default	Description
14:13	R/W	FSM/VSPI clock select	2	1	These bits set the autocalibration FSM and VSPI clock (50 MHz maximum) 0: input crystal reference 1: input crystal reference divide by 4 2: input crystal reference divide by 16 3: input crystal reference divide by 32
16:15	R/W	Reserved	2	0	Reserved

PHASE DETECTOR (PD) REGISTER

Table 25. Register 0x0B, PD Register (Default 0x0F8061)

Bit	Type	Name	Width	Default	Description
2:0	R/W	PD_DEL_SEL	3	1	Sets PD reset path delay (recommended setting is 001).
4:3	R/W	Reserved	2	0	Reserved.
5	R/W	PD_UP_EN	1	1	Enables the PD up output.
6	R/W	PD_DN_EN	1	1	Enables the PD down output.
8:7	R/W	CSP mode	2	0	Cycle slip prevention mode. This delay varies by $\pm 10\%$ with temperature, and $\pm 12\%$ with process. Extra current is driven into the loop filter when the phase error is larger than the following: 0 = disabled 1 = 5.4 ns 2 = 14.4 ns 3 = 24.1 ns
9	R/W	Force CP up	1	0	Forces CP up output to turn on; use for test only.
10	R/W	Force CP DN	1	0	Forces CP down output to turn on; use for test only.
23:11	R/W	Reserved	13	496d 0x1F0	Reserved.

EXACT FREQUENCY MODE REGISTER

Table 26. Register 0x0C, Exact Frequency Mode Register (Default 0x000000)

Bit	Type	Name	Width	Default	Description
13:0	R/W	Number of Channels per f_{PD}	14	0	The comparison frequency divided by the correction rate must be an integer. Frequencies at exactly the correction rate have zero frequency error. 0: disabled. 1: disabled. 2: 16383d (0x3FFF).

GENERAL-PURPOSE, SERIAL PORT INTERFACE, AND REFERENCE DIVIDER (GPO_SPI_RDIV) REGISTER

Table 27. Register 0x0F, GPO_SPI_RDIV Register (Default 0x000001)

Bit	Type	Name	Width	Default	Description
4:0	R/W	GPO_SELECT	5	1d	The signal selected here is an output to the SDO pin when the SDO pin is enable via Register 0x08[5] 0: data from Register 0x0F[5] 1: lock detect output 2: lock detect trigger 3: lock detect window output 4: ring oscillator test 5: pull-up hard from CSP 6: pull-down hard from CSP 7: reserved 8: reference buffer output 9: reference divider output 10: VCO divider output 11: modulator clock from VCO divider 12: auxiliary clock 13: auxiliary SPI clock 14: auxiliary SPI enable 15: auxiliary SPI data output 16: PD down 17: PD up 18: SD3 clock delay 19: SD3 core clock 20: autostrobe integer write 21: autostrobe fractional write 22: autostrobe auxiliary SPI 23: SPI latch enable 24: VCO divider sync reset 25: seed load strobe 26 to 29: not used 30: SPI output buffer enable 31: soft reset, \overline{RST}
5	R/W	GPO test data	1	0	1: GPO test data
6	R/W	Prevent automux SDO	1	0	1: outputs GPO data only 0: automuxes between SDO and GPO data
7	R/W	LDO driver always on	1	0	1: LD_SDO pin driver always on 0: LD_SDO pin driver only on during SPI read cycle
8	R/W	Disable PFET	1	0	
9	R/W	Disable NFET	1	0	

VCO TUNE REGISTER

The VCO tune register is a read only register.

Table 28. Register 0x10, VCO Tune Register (Default 0x000020)

Bit	Type	Name	Width	Default	Description
7:0	R	VCO switch setting	8	32	Indicates the VCO switch setting selected by the autocalibration state machine to yield the nearest free running VCO frequency to the desired operating frequency. Not valid when Register 0x10[8] = 1, autocalibration busy. Note that when a manual change is made to the VCO switch settings, this register does not indicate the current VCO switch position. VCO subsystems may not use all the MSBs, in which case the unused bits are don't care. 0 = highest frequency. 1 = second highest frequency. ... 255 = lowest frequency.
8	R	Autocalibration busy	1	0	Busy when the autocalibration state machine is searching for the nearest switch setting to the requested frequency.

SAR REGISTER

The SAR register is a read only register.

Register 0x11, SAR Register (Default 0x07FFFF)

Bit	Type	Name	Width	Default	Description
18:0	R	SAR error magnitude counts	19	2 ¹⁹ to 1	SAR error magnitude counts
19	R	SAR error sign	1	0	SAR error sign 0 = +ve 1 = -ve

GENERAL-PURPOSE 2 REGISTER

The GPO2 register is a read only register.

Table 29. Register 0x12, GPO2 Register (Default 0x000000)

Bit	Type	Name	Width	Default	Description
0	R	GPO	1	0	GPO state
1	R	Lock detect	1	0	Lock detect status 1 = locked 0 = unlocked

BUILT-IN SELF TEST REGISTER

The BIST register is a read only register.

Table 30. Register 0x13, BIST Register (Default 0x001259)

Bit	Type	Name	Width	Default	Description
16:0	R	Reserved	17	4697d	Reserved

VCO SUBSYSTEM REGISTER MAP

The VCO subsystem uses indirect addressing via Register 0x05. For more detailed information on how to write to the VCO subsystem, see the VCO Serial Port Interface (VSPI) section.

The VCO tuning register is write only.

Table 31. VCO_REG 0x00 Tuning

Bit	Type	Name	Width	Default	Description
0	W	CAL	1	0	VCO tune voltage is redirected to a temperature compensated calibration voltage
8:1	W	CAPS	8	16	VCO subband selection 0: maximum frequency 1111 1111: minimum frequency

VCO ENABLE REGISTER

The VCO enable register is a write only register.

Table 32. VCO_REG 0x01 Enable

Bit	Type	Name	Width	Default	Description
0	W	Master enable VCO subsystem	1	1	0: all VCO subsystem blocks are turned off.
1	W	VCO enable	1	1	Enables VCOs.
2	W	PLL buffer enable	1	1	Enables PLL buffer to N divider.
3	W	Input/output master enable	1	1	Enables output stage and the output divider. It does not enable/disable the VCO.
4	W	Reserved	1	1	Reserved.
5	W	Output stage enable	1	1	Output stage enable.
7:6	W	Reserved	2	3	Reserved.
8	W	Reserved	1	1	Reserved.

Example: Disabling the Output Stage of the VCO Subsystem

To disable the output stage of the VCO subsystem of the [HMC832](#), clear Bit 5 in VCO_REG 0x01. If the other bits are left unchanged, then write 1 1101 1111 into VCO_REG 0x01.

The VCO subsystem register is accessed via a write to PLL subsystem Register 0x05 = 1 1101 1111 0001 00 = 0xEF88.

Register 0x05[2:0] = 000; VCO subsystem ID 0.

Register 0x05[6:3] = 0001; VCO subsystem register address.

Register 0x05[7] = 1; master enable.

Register 0x05[8] = 1; VCO enable.

Register 0x05[9] = 1; PLL buffer enable.

Register 0x05[10] = 1; I/O master enable.

Register 0x05[11] = 1; reserved.

Register 0x05[12] = 0; disable the output stage.

Register 0x05[14:13] = 11b.

Register 0x05[15] = 1; don't care.

VCO OUTPUT DIVIDER REGISTER

This is a write only register. Note that to write 0_1111_1110 into VCO_REG 0x02 VCO subsystem (VCO_ID = 000b), and set the VCO output divider to divide by 62, the following needs to be written to Register 0x05 = 0_1111_1110, 0010, 000 b.

Register 0x05[2:0] = 000; Subsystem ID 0

Register 0x05[6:3] = 0010; VCO Register Address 2d.

Register 0x05[16:7] = 0_1111_1110; divide by 62, maximum output RF gain.

Table 33. VCO_REG 0x02 VCO Output Divider

Bit	Type	Name	Width	Default	Description
5:0	W	RF divide ratio	6	1	0: mutes the output when VCO_REG 0x03[8:7] = 0d 1: fo 2: fo/2 3: invalid, defaults to 2 4: fo/4 5: invalid, defaults to 4 6: fo/6 ... 60: fo/60 61: invalid, defaults to 60 62: fo/62 > 62 invalid, defaults to 62
8:6	W	Reserved	3	0	Reserved

VCO CONFIGURATION REGISTER

The VCO configuration register is a write only register.

Table 34. VCO_REG 0x03 Configuration

Bit	Type	Name	Width	Default	Description
1:0	W	Programmable performance mode	2	2	Selects output noise floor performance level at a cost of increased current consumption. 01: low current consumption mode. 11: high performance mode. Other states (00 and 10) not supported.
2	W	RF_N output enable	1	0	Enables the output on RF_N pin. Required for differential operation, or single-ended output on the RF_N pin.
3	W	RF_P output enable	1	0	Enables the output on RF_P pin. Required for differential operation, or single-ended output on the RF_P pin.
4	W	Reserved	1	1	Reserved.
5	W	Return loss	1	0	0: return loss = -5 dB typical (highest output power). 1: return loss = -10 dB typical.
6	W	Reserved	1	0	Reserved.
8:7	W	Mute mode	2	1	Defines when the mute function is enabled (the output is muted), see the VCO Output Mute Function section, and Figure 35 for more information. 00: enables mute when the divide ratio, VCO_REG 0x02[5:0] = 0. This enables the HMC832 to be backwards compatible to the HMC830 mute function. 01: during VCO calibration (see the VCO Calibration section for more details). 10: not supported. 11: mute all RF outputs (unconditional).

VCO CALIBRATION/BIAS, CF CALIBRATION, AND MSB CALIBRATION REGISTERS

These registers are write only. Note that, specified performance is only guaranteed with the required settings in Table 35 only; other settings are not supported.

Table 35. VCO_REG 0x04 CAL/Bias

Bit	Type	Name	Width	Default	Description
0	W	Initialization	9	201d	Reserved

Table 36. VCO_REG 0x05 CF_CAL

Bit	Type	Name	Width	Default	Description
8:0	W	Reserved	9	170d	Reserved

Table 37. VCO_REG 0x06 MSB Calibration

Bit	Type	Name	Width	Default	Description
8:0	W	Reserved	9	255d	Reserved

VCO OUTPUT POWER CONTROL

The VCO power control register is write only.

Table 38. VCO_REG 0x07 Output Power Control

Bit	Type	Name	Width	Default	Description
3:0	W	Output stage gain control	4	1	Output stage gain control in 1 dB steps 0d: 0 dB gain 1d: 1 dB gain 2d: 2 dB gain ... 10d: 10 dB gain 11d: 11 dB gain
4	W	Initialization	1	0	Program to 1d
8:5	W	Reserved	4	4d	Program 4d

EVALUATION PRINTED CIRCUIT BOARD (PCB)

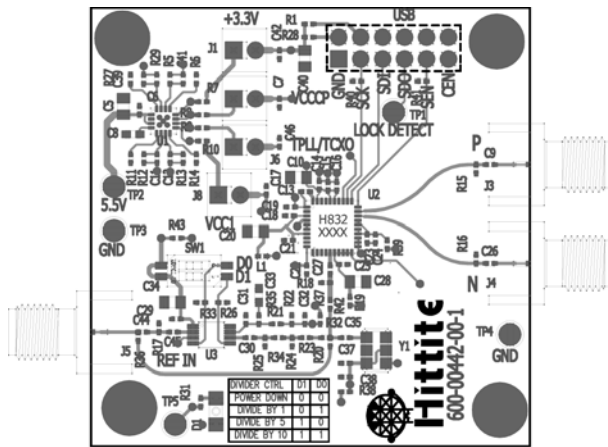

Figure 53. Silk Screen and PCB Traces Top Layer

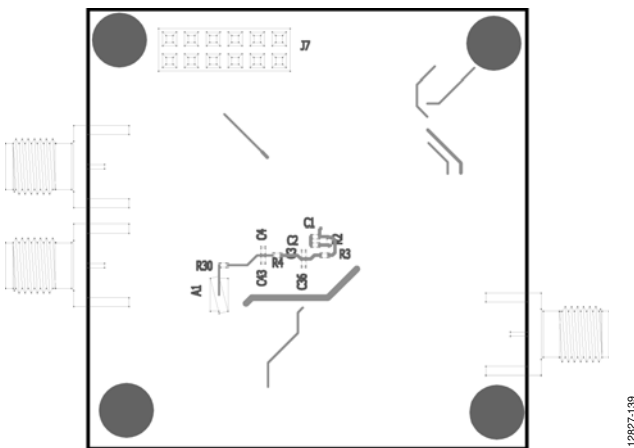

Figure 54. Silk Screen and PCB Traces Bottom Layer

The circuit board used in the application uses RF circuit design techniques. Signal lines have 50 Ω impedance whereas the package ground leads and exposed paddle are connected directly to the ground plane similar to that shown in Figure 53 and Figure 54. Use a sufficient number of via holes to connect the top and bottom ground planes. The evaluation circuit board shown Figure 53 and Figure 54 is available from Analog Devices upon request.

CHANGING EVALUATION BOARD REFERENCE FREQUENCY AND CP CURRENT CONFIGURATION

The evaluation board is provided with a 50 MHz on board reference oscillator, and Type 1 loop filter configuration, as shown in Figure 52 (~127 kHz bandwidth, see Table 12).

The default register configuration file included in the Analog Devices PLL evaluation software sets the comparison frequency to 50 MHz ($R = 1$, that is, Register 0x02 = 1).

As with all PLLs and PLL with integrated VCOs, modifying the comparison frequency or charge pump (CP) current results in changes to the loop dynamics and ultimately, phase noise performance. When making these changes there are several items to keep in mind:

- CP offset current setting: refer to the Charge Pump (CP) and Phase Detector (PD) section.
- LD configuration: refer to the Lock Detect section.

To redesign the loop filter for a particular application, download the PLL design software tool by clicking on the software download link on the [HMC832](#) product page. Analog Devices PLL design enables users to accurately model and analyze performance of all Analog Devices PLLs, PLLs with integrated VCOs, and clock generators. It supports various loop filter topologies, and enables users to design custom loop filters and accurately simulate resulting performance. For more information, see the Loop Filter and Frequency Changes section.

For evaluation purposes, the [HMC832](#) evaluation board is shipped with an on-board, low cost, low noise (100 ppm), 50 MHz VCXO, enabling evaluation of most parameters including phase noise without any external references.

Exact phase or frequency measurements require the [HMC832](#) to use the same reference as the measuring instrument. To accommodate this requirement, the [HMC832](#) evaluation board includes the [HMC1031MS8E](#); a simple low current integer-N PLL that can lock the on-board VCXO to an external 10 MHz reference input commonly provided by most test equipment. To lock the [HMC832](#) to an external 10 MHz reference, connect the external reference output to the J5 input of the [HMC832](#) evaluation board and change the [HMC1031MS8E](#) integer divider value to 5 by changing the switch settings, D1 = 1 (SW1 to SW4 closed), and D0 = 0 (SW2 to SW3 open), for more information see the [HMC1031MS8E](#) data sheet.

EVALUATION KIT CONTENTS

The evaluation kit contains one [HMC832LP6GE](#) evaluation PCB, a USB interface board, a six-foot USB A-male to USB B-female cable, a CD ROM that contains the user manual, evaluation PCB schematic, evaluation software, and Analog Devices PLL design software. To order the evaluation kit, see the Ordering Guide section for the product number.

OUTLINE DIMENSIONS

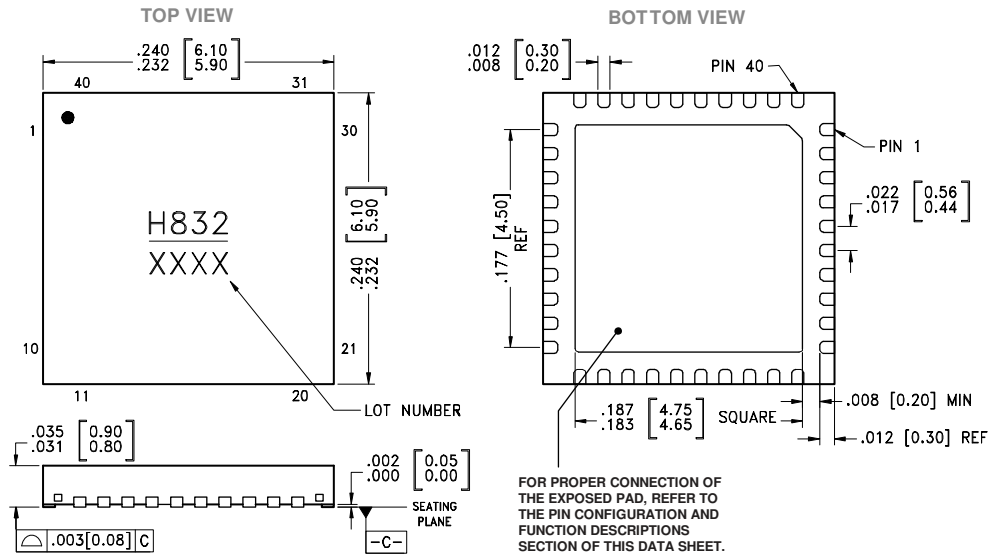

- NOTES:
1. PACKAGE BODY MATERIAL: LOW STRESS INJECTION MOLDED PLASTIC SILICA AND SILICON IMPREGNATED.
 2. LEAD AND GROUND PADDLE MATERIAL: COPPER ALLOY.
 3. LEAD AND GROUND PADDLE PLATING: 100% MATTE TIN.
 4. DIMENSIONS ARE IN INCHES [MILLIMETERS].
 5. LEAD SPACING TOLERANCE IS NON-CUMULATIVE.
 6. PAD BURR LENGTH SHALL BE 0.15mm MAX. PAD BURR HEIGHT SHALL BE 0.25mm max.
 7. PACKAGE WARP SHALL NOT EXCEED 0.05mm.
 9. REFER TO HITITE APPLICATION NOTE FOR SUGGESTED PCB LAND PATTERN.

Figure 55. 40-Lead Quad Flat No-Lead Package [QFN]
6 mm x 6 mm Body, Very Thin Quad
Dimensions shown in inches and [millimeters]

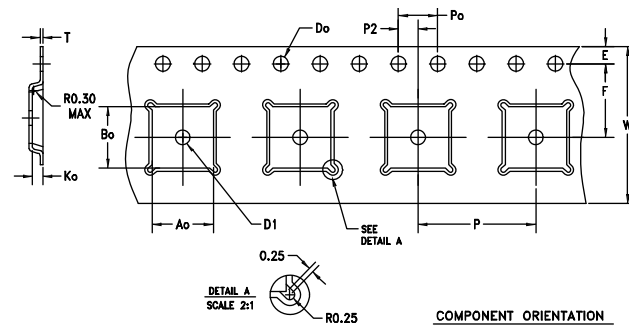

CAVITY: LP6

DIMENSION	SPEC
W	16.00 +/-0.30
Do	Ø1.5 +0.1/-0.0
Po (SEE NOTE 2)	4.00 +/-0.10
E	1.75 +/-0.10
D1	Ø1.5 MIN
Ao	6.30 +/-0.10
Bo	6.30 +/-0.10
P	12.00 +/-0.10
P2 (SEE NOTE 7)	2.00 +/-0.05
Ko	1.10 +/-0.10
T	0.30 +/-0.05
F (SEE NOTE 7)	7.50 +/-0.10

- COMPONENT ORIENTATION
(FORWARD TAPE AND REEL)
- USER DIRECTION OF FEED
- NOTES:
1. ALL DIMENSIONS ARE IN MILLIMETERS.
 2. 10 SPROCKET HOLE PITCH CUMULATIVE TOLERANCE ±0.2
 3. CAMBER NOT TO EXCEED 1mm IN 100mm
 4. MATERIAL: CONDUCTIVE /BLACK POLYSTYRENE
 5. Ao AND Bo MEASURED ON A PLANE 0.3mm ABOVE THE BOTTOM OF THE POCKET
 6. Ko MEASURED FROM A PLANE ON THE INSIDE BOTTOM OF THE POCKET TO THE TOP SURFACE OF THE CARRIER
 7. POCKET POSITION RELATIVE TO SPROCKET HOLE MEASURED AS TRUE POSITION OF POCKET, NOT POCKET HOLE

Figure 56. Tape and Reel Outline Dimensions
Dimensions shown in millimeters

ORDERING GUIDE

Model ¹	Lead Finish	MSL Rating	Temperature	Package Description	Qty.	Brand ²
HMC832LP6GE	100% matte Sn	MSL1	-40°C to +85°C	40-Lead Quad Flat No-Lead Package [QFN], Low Stress Injection Molded Plastic	500	<u>H832</u> XXXX
HMC832LP6GETR	100% matte Sn	MSL1	-40°C to +85°C	40-Lead Quad Flat No-Lead Package [QFN], Low Stress Injection Molded Plastic, 7" Tape and Reel		<u>H832</u> XXXX
EKIT01-HMC832LP6G EVAL01-HMC832LP6G				Evaluation Kit Evaluation Board		

¹ E = RoHS Compliant Part.

² Four-digit lot number XXXX.