

**STRAIGHT PLUG FULL CRIMP-TYPE
CABLE 5/50 S**

R124.075.323
SERIES SMA-COM

Hex. .315/flats
(Hex. 8/plats)

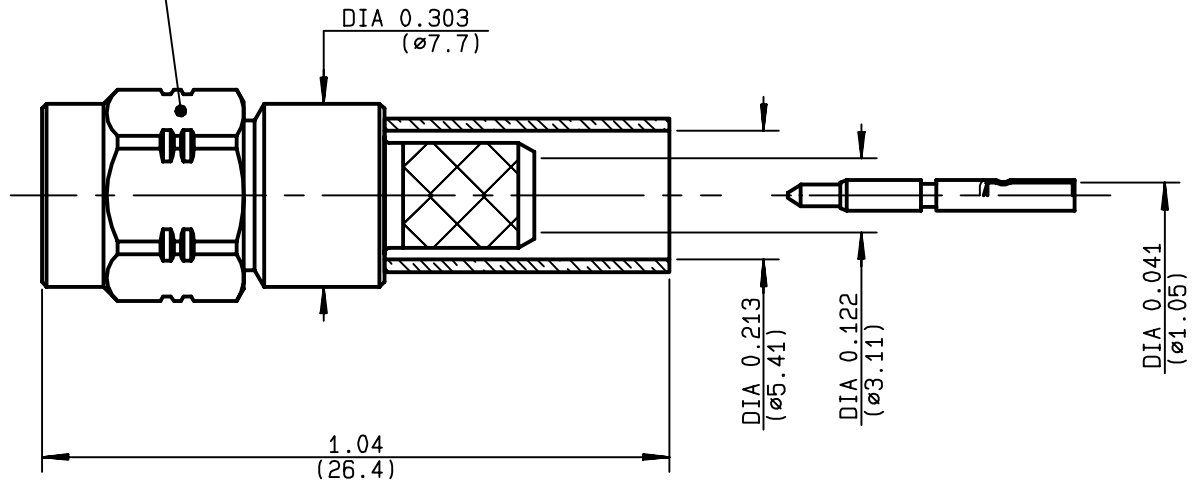

NOMINAL IMPEDANCE	50 Ω
FREQUENCY RANGE	0-12.4 GHz
TEMPERATURE RATING	-65/+165 °C
V.S.W.R	1.15 + .01 x F(GHz)Maxi
RF INSERTION LOSS	0.05 √F(GHz) dB Maxi
VOLTAGE RATING	335 Veff Maxi
DIELECTRIC WITHSTANDING VOLTAGE	1000 Veff Mini
INSULATION RESISTANCE	5000 MΩMini
HERMETIC SEAL	NA Atm.cm ³ /s
LEAKAGE (pressurized only)	NA
MECHANICAL DURABILITY	100 Cycles
WEIGHT	5.2 gr
SPECIFICATION	

CABLES : **KX 15**
RG 141
RG 58

OTHERS CHARACTERISTICS

CABLE RETENTION	180 N Mini
CENTER CONTACT RETENTION	
Axial force - mating end	18 N Mini
Axial force - opposite end	18 N Mini
Torque	NA cm.N Mini
RECOMMENDED TORQUES	
Mating	60 cm.N
Panel nut	NA cm.N
Clamp nut	NA cm.N

CONNECTOR PARTS : MATERIALS

BODY	BRASS
OUTER CONTACT	
CENTER CONTACT	BRASS
INSULATOR	PTFE
GASKET	
OTHERS PIECES	BRASS

FINISH (all values are given in micrometers)

BODY	GOLD 0.2 OVER NICKEL 2
OUTER CONTACT	
CENTER CONTACT	GOLD 1.3 OVER COPPER 2.5
INSULATOR	-
GASKET	-
OTHERS PIECES	GOLD 0.2 OVER NICKEL 2

TRIQUES

ISSUE	CREATION DATE	FILE PART-NUMBER
9847B00	20/05/1996	96-1000-052



RADIALL®

The information given here is subject to change without notice.
Design changes may be in order to improve the product .

Connect to the future



R124.075.323

ISSUE 9847B00 SERIES SMA-COM

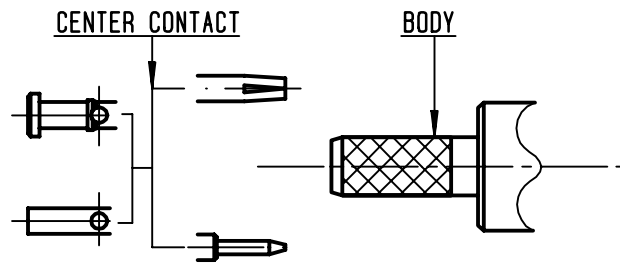
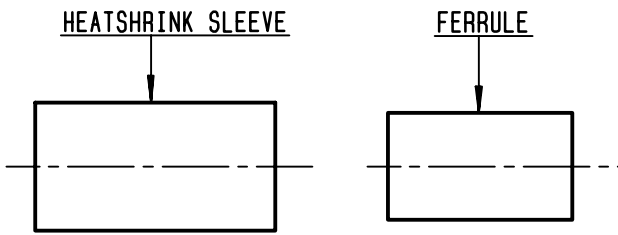

①

Slide heatshrink sleeve (R280.637.030-Option) and ferrule onto cable. Strip the cable.

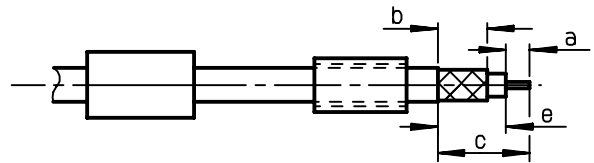

Stripping	a	b	c	d	e
inch	0.118	0.248	0.425	0	0.307
mm	3	6.3	10.8		7.8

②

Slide center contact on until it bottoms against cable dielectric. Solder or crimp center contact. Crimping tool : R282.281.000 (2 x 4 pts) position 7 + positionner R282.967.012.

SOLDER / CRIMPING

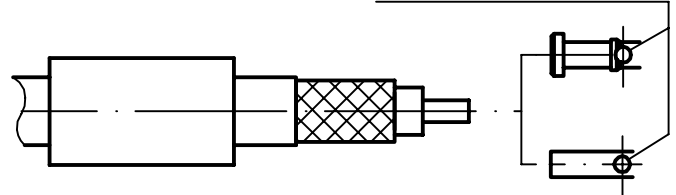

③

Fan the braid. Slide cable into the body by overtaking the insulator hard mounting point. Slide ferrule over the braid. (In direction F)

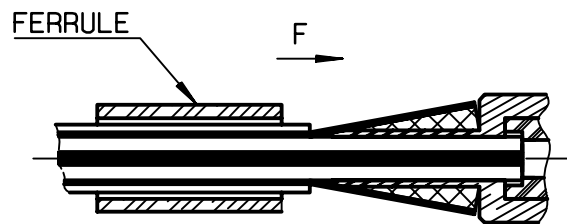

④

Crimp the ferrule with crimping tool R282.223.000 (Hex. : .213)(5.41) or crimping tool R282.293.000 (M22520/5-01) + dies R282.235.011 (M22520/5-11) Cut excess of braid if necessary. Slide sleeve over ferrule and heatshrink in place (Option)

Shrink the heatshrink sleeve

