

PANEL CUT OUT

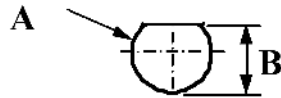

inches		
	Maxi	mini
A	.198	.192
B	.183	.177

REVISIONS			
REV.	DESCRIPTION	DATE	APPROVED
A	INITIAL RELEASE	03/07/18	C.E.

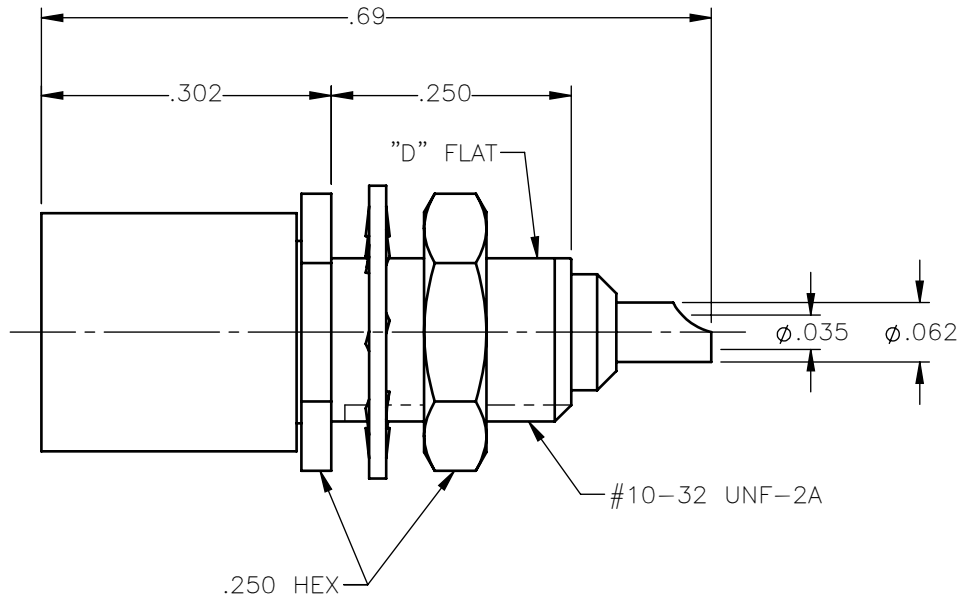



NOTES:

MATERIALS:

1. BODY & NUT = BRASS PER ASTM B16, ALLOY C36000, TEMPER H02.
2. INSULATOR = VIRGIN WHITE TEFLON PER ASTM D1710, GRADE 1, TYPE I, CLASS "B".
3. CONTACT & SPRING = BERYLLIUM COPPER PER ASTM B196, ALLOY C17300, TEMPER TD04.
4. LOCKWASHER = PHOSPHOR BRONZE PER ASTM B139, COPPER ALLOY C53400, TEMPER H04.
5. SLEEVE = BRASS PER C36000, ANNEALING 1H AT 500°C, HARDNESS 80-120 HV.

FINISHES:

1. CONTACT = GOLD PLATE PER ASTM B488-11, TYPE II, 50µin MIN, GRADE C, OVER 100 TO 200µin STRESS FREE SULFAMATE NICKEL PER AMS-QQ-N-290.
2. SPRING = NICKEL PLATE PER AMS-QQ-N-290, CLASS 1, GRADE G, EXCEPT 100 TO 200µin THICK OVER 50 TO 100µin THICK COPPER PER AMS 2418.
3. ALL OTHER METAL PARTS = GOLD PLATE PER ASTM B488-11, TYPE II, 30µin MIN, GRADE C OVER 100 TO 200µin COPPER STRIKE PER AMS 2418.

UNLESS OTHERWISE SPECIFIED DIMENSIONS ARE IN INCHES TOLERANCES ON	DWN: C.E.	DATE: 03/07/18	 Property of Radiall This document cannot be reproduced or communicated to a third party without prior written permission of RADIALL.	
	CHKD: D.N.	DATE: 03/07/18		
DECIMAL	ANGLE	APVD: J.M.	DATE: 03/07/18	SLB STRAIGHT FEMALE PLUG BULKHEAD FRONT MOUNT SOLDER POT RECEPTACLE
REFERENCE:	MATERIALS & FINISHES:	SIZE: A	FSCM NO.: 19505	
ORIGINATED: C.E. DATE: 03/07/18	SEE NOTES	DWG. NO.: 3017-1511-000	REV: A	
		SCALE: 5:1	THIRD ANGLE PROJECTION	SHEET 1 OF 1

3017-1511-000