

TPS22951 Current-Limited 1-Ω Smart-Load Switch

1 Features

- 1-Ω P-Channel MOSFET
- 300-mA Continuous Source Current
- Thermal and Short-Circuit Protection
- 600-mA Current Limit
- Operating Range: $V_{CC} = 2.8\text{ V to }5.3\text{ V}$
- 41- μs Typical Rise Time
- 10- μA Maximum Standby Supply Current
- Ambient Temperature Range: $-40^{\circ}\text{C to }+85^{\circ}\text{C}$
- ESD Performance Tested Per JESD 22
 - 4000-V Human-Body Model (HBM)
 - 400-V Machine Model (MM)
 - 1000-V Charged-Device Model (CDM)

2 Applications

- Smart Phones
- Notebooks
- Digital Cameras
- Peripheral Ports

3 Description

The TPS22951 smart-load switch is intended for applications where heavy capacitive loads and short circuits are likely to be encountered. This device incorporates a 1-Ω P-channel MOSFET power switch for power distribution. The switch is controlled by a logic enable (EN) input and an accessory detect (DET) pin. The switch is active when EN is high and DET is low. The switch is disabled if EN is low or DET is high. A low power state is achieved by driving EN low.

When the output load exceeds the current-limit threshold or a short is present, the device limits the output current to a safe level by increasing the on resistance of the power switch. When continuous heavy overloads and short circuits increase the power dissipation in the switch, causing the junction temperature to rise, a thermal-protection circuit shuts off the switch to prevent damage. The device recovers from a thermal shutdown once the device has cooled sufficiently, but the switch remains OFF until EN is toggled. This smart-load switch is designed to set current limit at 600 mA maximum.

Device Information⁽¹⁾

PART NUMBER	PACKAGE	BODY SIZE (NOM)
TPS22951	DSBGA (6)	1.20 mm x 0.80 mm

(1) For all available packages, see the orderable addendum at the end of the data sheet.

Simplified Schematic

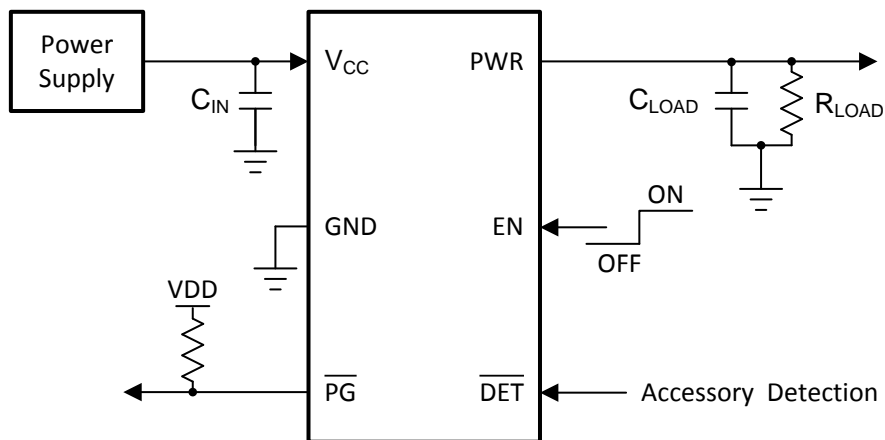

Table of Contents

1 Features	1	8.3 Feature Description	10
2 Applications	1	8.4 Device Functional Modes	10
3 Description	1	9 Application and Implementation	11
4 Revision History	2	9.1 Application Information	11
5 Pin Configurations and Functions	3	9.2 Typical Application	11
6 Specifications	4	10 Power Supply Recommendations	12
6.1 Absolute Maximum Ratings	4	11 Layout	13
6.2 ESD Ratings	4	11.1 Layout Guidelines	13
6.3 Recommended Operating Conditions	4	11.2 Layout Example	13
6.4 Thermal Information	4	11.3 Thermal Considerations	13
6.5 Electrical Characteristics	5	12 Device and Documentation Support	15
6.6 Timing Requirements	5	12.1 Documentation Support	15
6.7 Switching Characteristics	5	12.2 Receiving Notification of Documentation Updates	15
6.8 Typical Characteristics	6	12.3 Community Resources	15
7 Parameter Measurement Information	8	12.4 Trademarks	15
8 Detailed Description	9	12.5 Electrostatic Discharge Caution	15
8.1 Overview	9	12.6 Glossary	15
8.2 Functional Block Diagram	9	13 Mechanical, Packaging, and Orderable Information	15

4 Revision History

NOTE: Page numbers for previous revisions may differ from page numbers in the current version.

Changes from Revision C (March 2015) to Revision D	Page
• Changed all instances of "POK" to "PG" in the data sheet	1

Changes from Revision B (November 2012) to Revision C	Page
• Added <i>Pin Configuration and Functions</i> section, <i>ESD Ratings</i> table, <i>Feature Description</i> section, <i>Device Functional Modes</i> , <i>Application and Implementation</i> section, <i>Power Supply Recommendations</i> section, <i>Layout</i> section, <i>Device and Documentation Support</i> section, and <i>Mechanical, Packaging, and Orderable Information</i> section	1

Changes from Revision A (March 2009) to Revision B	Page
• Updated Top-Side Marking in the <i>Ordering Information</i> table	3

5 Pin Configurations and Functions

**YFP Package
6-Pin DSBGA
Top-Through View**

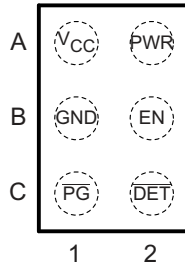

**YFP Package
6-Pin DSBGA
Top View**

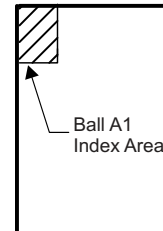

Pin Functions

Pin		I/O	DESCRIPTION
NO.	NAME		
A1	V _{CC}	I	Supply voltage
A2	PWR	O	Power switch output
B1	GND	—	Ground
B2	EN	I	Enable input ⁽¹⁾
C1	$\overline{\text{PG}}$	O	Power Good switch status open-drain output, active low
C2	$\overline{\text{DET}}$	I	Accessory detect, active low

(1) $\overline{\text{DET}}$ must be low for a minimum of 2 μs before EN is pulled high (see the [Timing Requirements](#) section).

6 Specifications

6.1 Absolute Maximum Ratings

over operating free-air temperature range (unless otherwise noted) ⁽¹⁾

		MIN	MAX	UNIT
V_{CC} ⁽²⁾	Supply voltage	-0.3	6	V
$V_{O(PWR)}$ ⁽²⁾	Output voltage	-0.3	$V_{CC} + 0.3$	V
$V_{I(EN)}, V_{I(DET)}$	Input voltage	-0.3	6	V
$V_{O(PG)}$	Voltage	-0.3	6	V
$I_{O(PWR)}$	Continuous output current	Internally limited		
	Continuous total power dissipation	See the Thermal Information section		
	Lead temperature soldering 1.6 mm (1/16 in) from case for 10 s	-0.3	6	V
T_J	Operating virtual junction temperature	-40	85	°C
T_{stg}	Storage temperature	-65	150	°C

- (1) Stresses beyond those listed under *Absolute Maximum Ratings* may cause permanent damage to the device. These are stress ratings only, which do not imply functional operation of the device at these or any other conditions beyond those indicated under *Recommended Operating Conditions*. Exposure to absolute-maximum-rated conditions for extended periods may affect device reliability.
- (2) All voltages are with respect to GND.

6.2 ESD Ratings

		VALUE	UNIT
$V_{(ESD)}$ Electrostatic discharge	Human body model (HBM), per ANSI/ESDA/JEDEC JS-001 ⁽¹⁾	4000	V
	Charged-device model (CDM), per JEDEC specification JESD22-C101 ⁽²⁾	1000	
	Machine model (MM)	400	

- (1) JEDEC document JEP155 states that 500-V HBM allows safe manufacturing with a standard ESD control process.
- (2) JEDEC document JEP157 states that 250-V CDM allows safe manufacturing with a standard ESD control process.

6.3 Recommended Operating Conditions

		MIN	MAX	UNIT
V_{CC}	Supply voltage	2.2	5.3	V
$V_{I(EN)}, V_{I(DET)}$	Input voltage	0	V_{CC}	V
$I_{O(PWR)}$	Continuous output current	0	-600	mA
T_J	Operating virtual junction temperature	-40	85	°C

6.4 Thermal Information

THERMAL METRIC ⁽¹⁾	TPS22951		UNIT
	YFP (DSBGA)		
	6 PINS		
$R_{\theta JA}$ Junction-to-ambient thermal resistance	125.1		°C/W
$R_{\theta JC(top)}$ Junction-to-case (top) thermal resistance	1.4		°C/W
$R_{\theta JB}$ Junction-to-board thermal resistance	26		°C/W
Ψ_{JT} Junction-to-top characterization parameter	0.3		°C/W
Ψ_{JB} Junction-to-board characterization parameter	26		°C/W
$R_{\theta JC(bot)}$ Junction-to-case (bottom) thermal resistance	N/A		°C/W

- (1) For more information about traditional and new thermal metrics, see the [Semiconductor and IC Package Thermal Metrics](#) application report.

6.5 Electrical Characteristics

over operating $-40^{\circ}\text{C} \leq T_J \leq +85^{\circ}\text{C}$ range (unless otherwise noted)

PARAMETER		TEST CONDITIONS ⁽¹⁾	MIN	TYP	MAX	UNIT
POWER SWITCH						
$r_{DS(on)}$	Static drain-source ON-state resistance, 3-V operation	$V_{CC} = 3\text{ V}$, $I_O = 0.3\text{ A}$			1	Ω
	Leakage current	PWR connected to GND, $V_{I(EN)} = 0\text{ V}$		1		μA
EN AND DET						
V_{IH}	High-level input voltage	$2.8\text{ V} \leq V_{CC} \leq 5.3\text{ V}$	1.35			V
V_{IL}	Low-level input voltage	$2.8\text{ V} \leq V_{CC} \leq 5.3\text{ V}$			0.45	V
I_I	Input current	$V_{I(EN)}$ or $V_{I(DET)} = 0\text{ V}$ or 5.3 V			1	μA
CURRENT LIMIT						
I_{OS}	Short-circuit output current	$V_{CC} = 2.8\text{ V}$ or 5.3 V , PWR connected to GND, Device enabled into short circuit	-0.3		-0.6	A
SUPPLY CURRENT						
	Supply current, enabled	No load on PWR, $V_{CC} = 5.3\text{ V}$, $V_{I(EN)} = V_{CC}$, $V_{I(DET)} = V_{CC}$ or 0 V			100	μA
	Supply current, disabled	No load on PWR, $V_{CC} = 5.3\text{ V}$, $V_{I(EN)} = 0\text{ V}$, $V_{I(DET)} = V_{CC}$ or 0 V			10	μA
PG						
$V_{OL(PG)}$	Power Good output low voltage	$I_{(PG)} = 1\text{ mA}$			0.4	V
	OFF-state current	$V_{(PG)} = 5.3\text{ V}$			1	μA
THERMAL SHUTDOWN						
	Thermal shutdown threshold ⁽²⁾		135			$^{\circ}\text{C}$
	Recovery from thermal shutdown ⁽²⁾		125			$^{\circ}\text{C}$
	Hysteresis ⁽²⁾			25		$^{\circ}\text{C}$

(1) Pulse-testing techniques maintain junction temperature close to ambient temperature; thermal effects must be taken into account separately.

(2) Not tested in production, specified by design

6.6 Timing Requirements

over operating free-air temperature range (unless otherwise noted)

		MIN	MAX	UNIT
t_{su}	Setup time, $\overline{\text{DET}}$ low before EN high	2		μs

6.7 Switching Characteristics

over operating free-air temperature range (unless otherwise noted)

PARAMETER		TEST CONDITIONS		MIN	TYP	MAX	UNIT
POWER SWITCH							
t_r ⁽¹⁾	Rise time, output	$V_{CC} = 5.3\text{ V}$	$C_L = 1\ \mu\text{F}$, $R_L = 20\ \Omega$	$T_J = 25^{\circ}\text{C}$	41		μs
		$V_{CC} = 2.8\text{ V}$			6		
t_f ⁽¹⁾	Fall time, output	$V_{CC} = 5.3\text{ V}$	$C_L = 1\ \mu\text{F}$, $R_L = 20\ \Omega$	$T_J = 25^{\circ}\text{C}$	43		μs
		$V_{CC} = 2.8\text{ V}$			43		
EN AND DET							
t_{on} ⁽¹⁾	Turnon time (EN to PWR)	$V_{CC} = 5.3\text{ V}$	$C_L = 1\ \mu\text{F}$, $R_L = 20\ \Omega$		42		μs
	Turnon time (EN to $\overline{\text{PG}}$)		$C_P = 15\text{ pF}$, $R_P = 10\text{ k}\Omega$		9.5		
t_{off} ⁽¹⁾	Turnoff time (EN to PWR)	$V_{CC} = 5.3\text{ V}$	$C_L = 1\ \mu\text{F}$, $R_L = 20\ \Omega$		48		μs
	Turnoff time (EN to $\overline{\text{PG}}$)		$C_P = 15\text{ pF}$, $R_P = 10\text{ k}\Omega$		47		

(1) Not tested in production, specified by design

6.8 Typical Characteristics

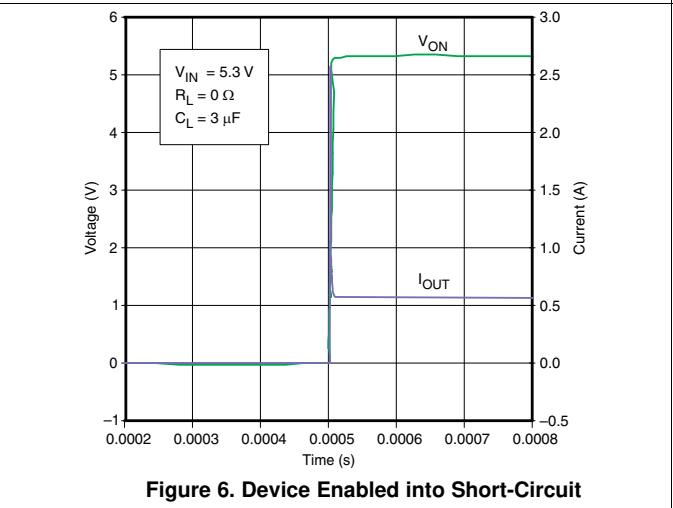
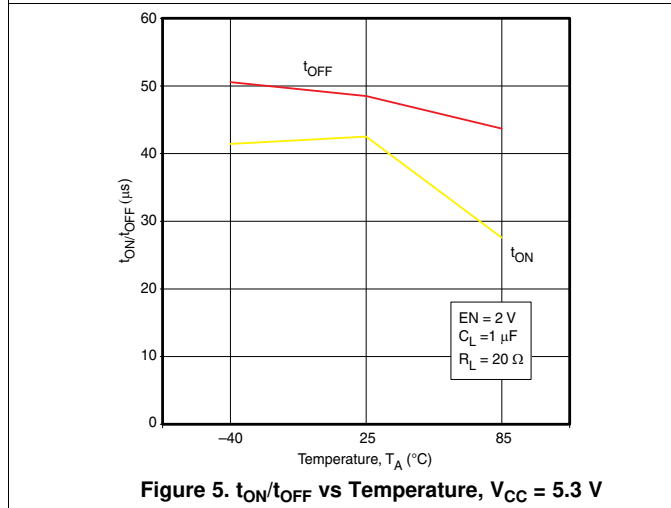
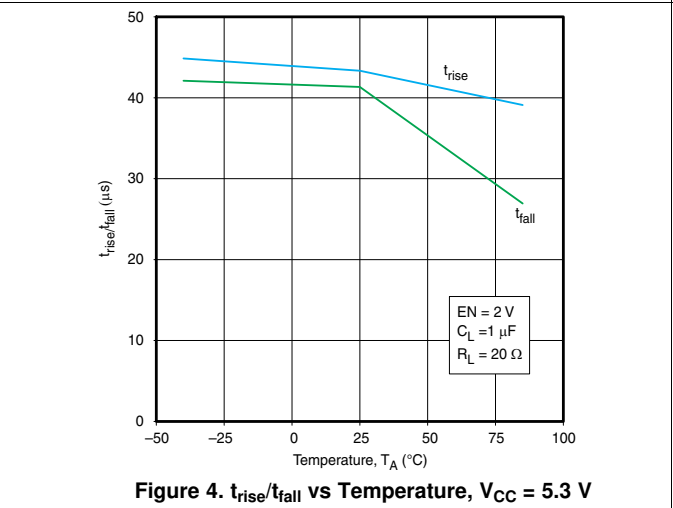
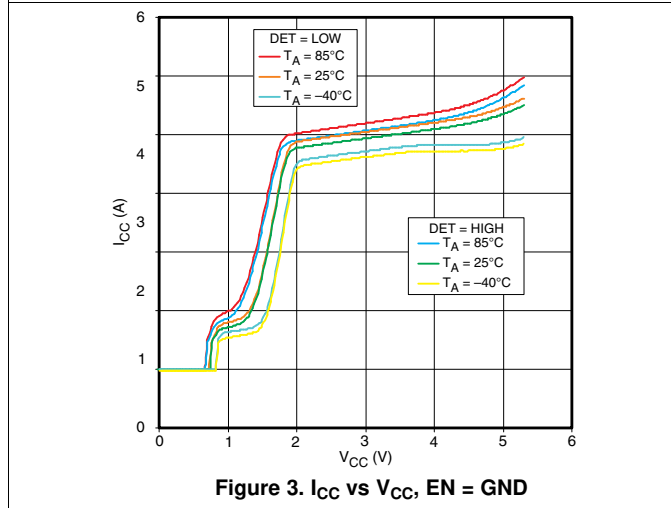
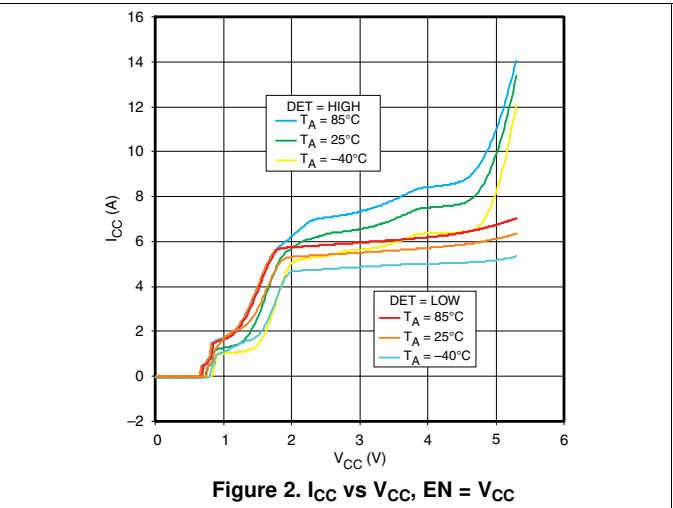
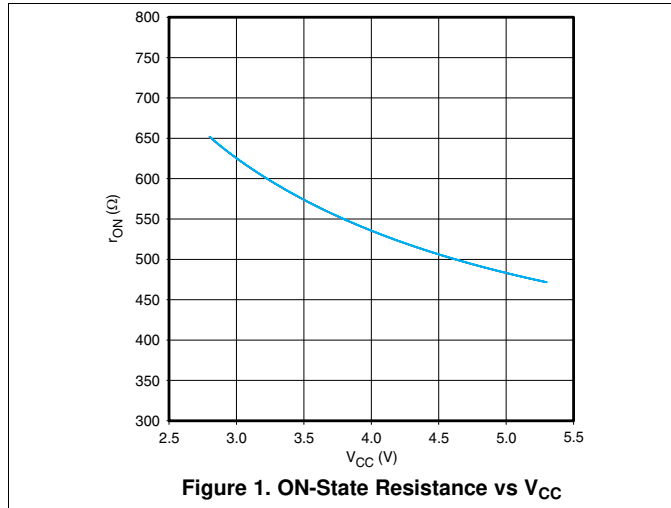

Typical Characteristics (continued)

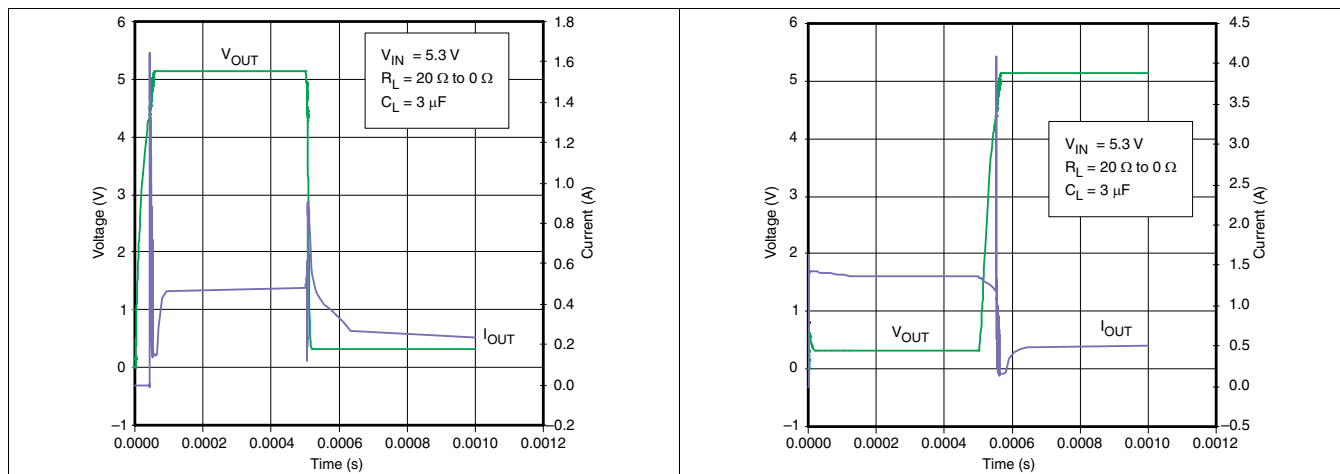

Figure 7. Full-Load to Short-Circuit Transient Response

Figure 8. Short-Circuit to Full-Load Recovery Response

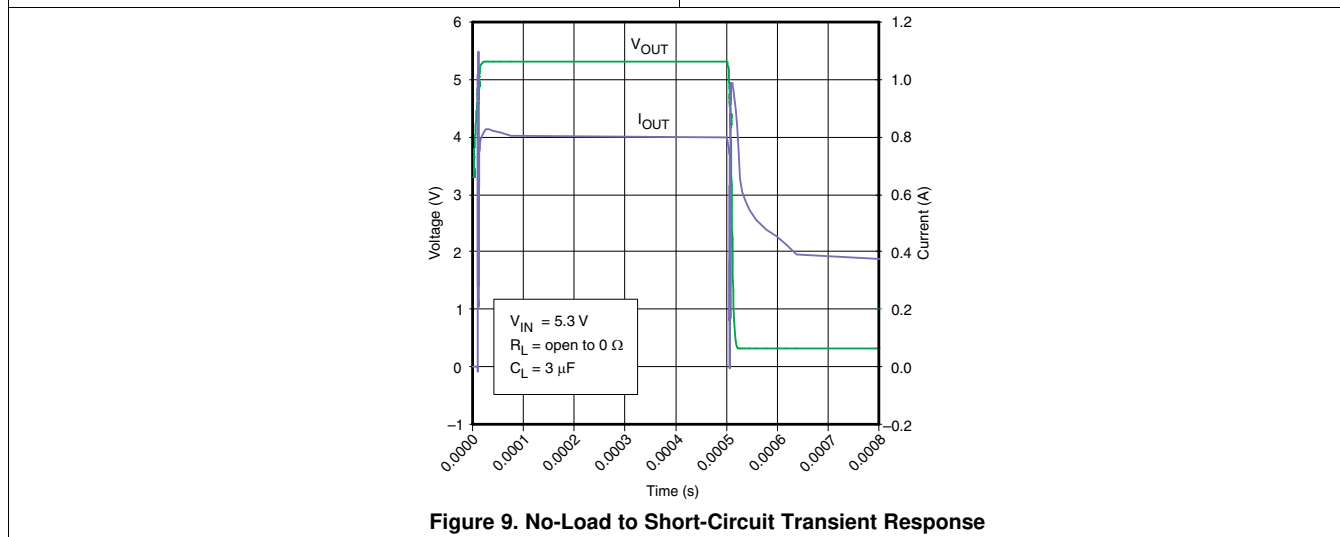

Figure 9. No-Load to Short-Circuit Transient Response

7 Parameter Measurement Information

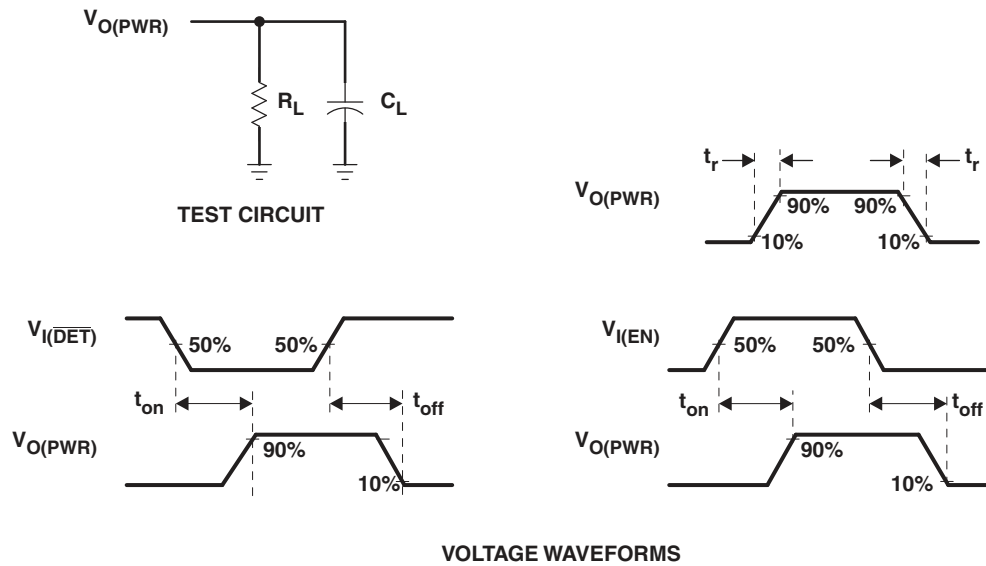

Figure 10. Test Circuit and Voltage Waveforms

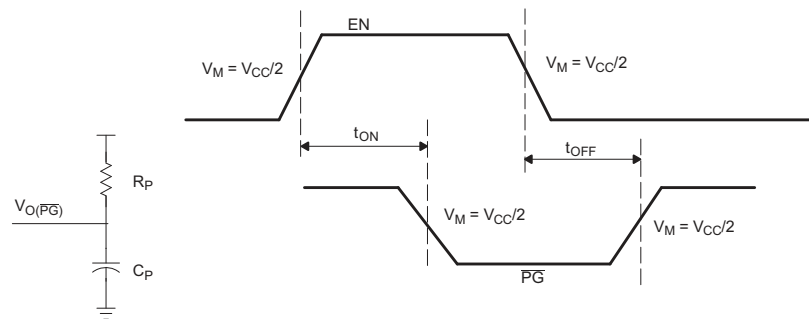

Figure 11. EN to $\overline{\text{PG}}$ Test Point

8 Detailed Description

8.1 Overview

The TPS22951 smart-load switch is intended for applications where heavy capacitive loads and short circuits are likely to be encountered. This device incorporates a 1- Ω P-channel MOSFET power switch for power distribution. The switch is controlled by a logic enable (EN) input and an accessory detect ($\overline{\text{DET}}$) pin. The switch is active when EN is high and $\overline{\text{DET}}$ is low. The switch is disabled if EN is low or $\overline{\text{DET}}$ is high. A low power state is achieved by driving EN low.

When the output load exceeds the current-limit threshold or a short is present, the device limits the output current to a safe level by increasing the on resistance of the power switch. When continuous heavy overloads and short circuits increase the power dissipation in the switch, causing the junction temperature to rise, a thermal-protection circuit shuts off the switch to prevent damage. The device recovers from a thermal shutdown once the device has cooled sufficiently, but the switch remains OFF until EN is toggled. This smart-load switch is designed to set current limit at 600 mA maximum.

8.2 Functional Block Diagram

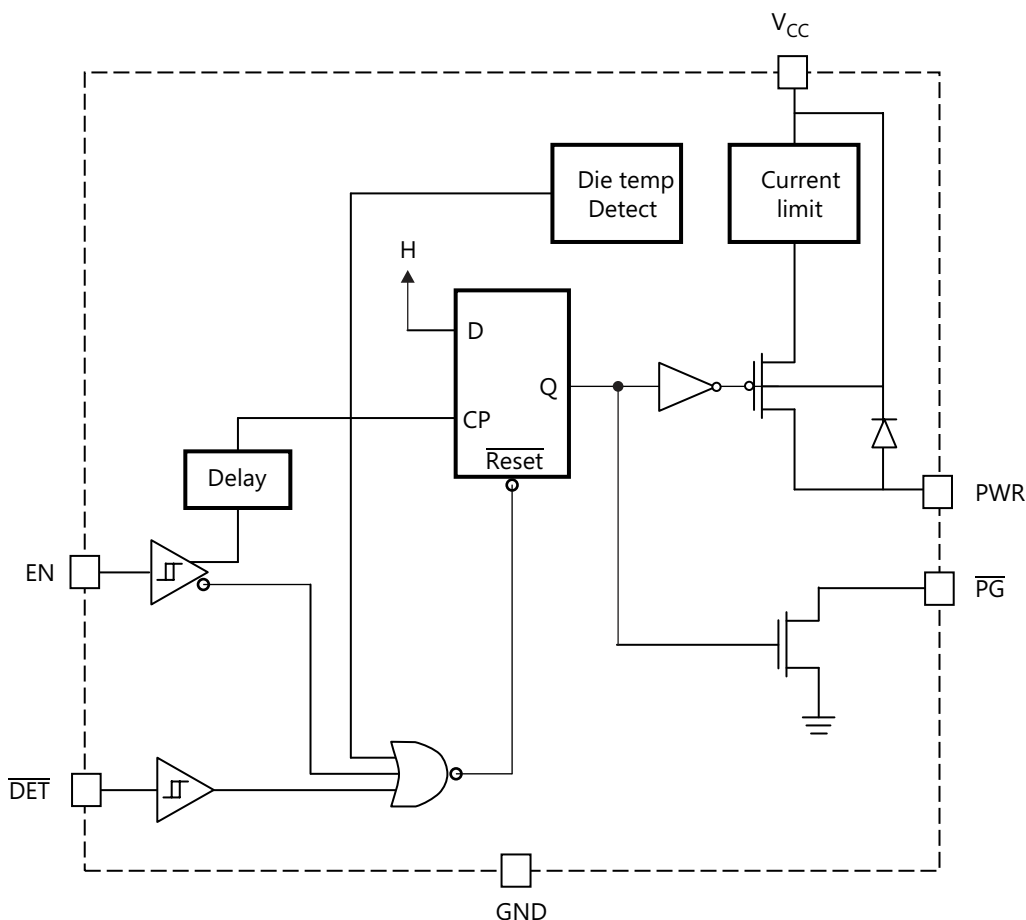

8.3 Feature Description

8.3.1 Current Limit

The TPS22951 includes a current-limiting feature. The current limit can help protect the system from high currents in the case of large capacitive loads and short circuits. When the load current exceeds the current limit threshold, the device limits the output current by increasing the on-resistance of the switch.

8.3.2 Power Good Indication

The TPS22951 includes an open-drain Power Good indication. This signal can be used to provide an indication to another component in the system. The signal behaves according to [Table 1](#).

To use the signal, the PG pin must be connected to a pullup resistor. The PG pin has an absolute maximum rating of 6 V and must not be pulled up to any voltage beyond 6 V. The pullup resistor must be in the range of 10 k Ω to limit the current flowing into the PG pin when the switch is on and the PG signal is low.

8.3.3 EN and DET inputs

The switch is controlled by the EN and DET pins. To enable the switch, the EN pin must be high and the DET pin must be low.

8.3.4 Thermal Shutdown

The TPS22951 includes a thermal shutdown circuit. If the device reaches the thermal shutdown threshold, the switch is automatically be disabled. The switch retrys after the device temperature has decreased and the EN pin is toggled from H to L to H.

8.4 Device Functional Modes

[Table 1](#) lists the functional modes of the TPS22951.

Table 1. Function Table

EN	$\overline{\text{DET}}$	CURRENT LIMIT	THERMAL LIMIT	POWER SWITCH (V _{CC} TO PWR)	$\overline{\text{PG}}$ (OPEN-DRAIN)
0	X	Not exceeded	Not exceeded	OFF	Z
X	1	Not exceeded	Not exceeded	OFF	Z
1	0	Not exceeded	Not exceeded	ON	L
1	0	Exceeded	Not exceeded	ON – current-limited	L
X	X	X	Exceeded ⁽¹⁾	OFF	Z

(1) To recover from a thermal event, the die temperature must first drop below the specified limit. EN must then be toggled to latch in the proper state of the flip-flop.

9 Application and Implementation

NOTE

Information in the following applications sections is not part of the TI component specification, and TI does not warrant its accuracy or completeness. TI's customers are responsible for determining suitability of components for their purposes. Customers should validate and test their design implementation to confirm system functionality.

9.1 Application Information

The input to output voltage drop in the device is determined by the R_{ON} of the device and the load current. The R_{ON} of the device depends upon the V_{CC} condition of the device. Refer to [Figure 1](#) r_{ON} vs V_{CC} to determine the r_{ON} of the device based upon the V_{CC} condition. Use [Equation 1](#) to calculate the input to output voltage drop:

$$\Delta V = I_{LOAD} \times R_{ON}$$

where

- ΔV = voltage drop from V_{CC} to PWR
 - I_{LOAD} = load current
 - R_{ON} = ON-Resistance of the device for a specific V_{CC}
- (1)

9.2 Typical Application

This application demonstrates how the TPS22951 can be used to protect against a short-circuit event. In this application, the PWR node is accidentally shorted to ground.

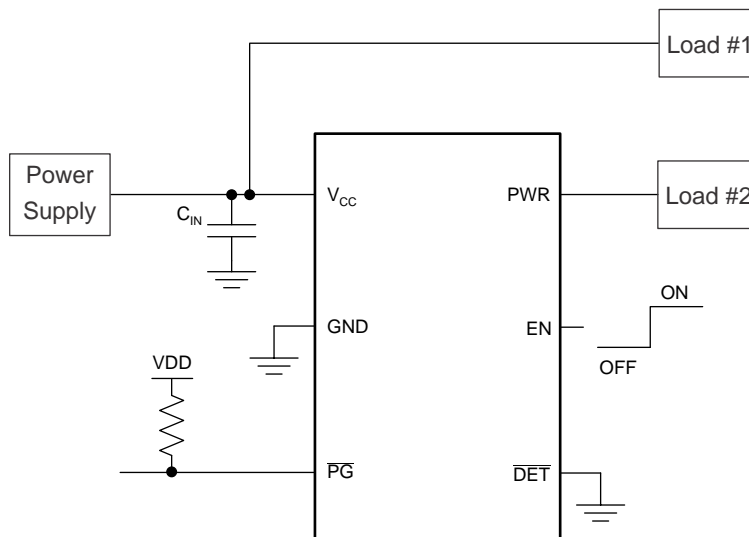

Figure 12. Typical Application Circuit

9.2.1 Design Requirements

For this design example, use the input parameters given in [Table 2](#):

Table 2. Design Parameters

DESIGN PARAMETER	EXAMPLE VALUE
Power Supply Maximum DC Output Current	2 A
Load 1 Current Consumption	1 A

9.2.2 Detailed Design Procedure

The power supply provides power to multiple loads. In the event that Load 2 is shorted to ground, the power supply must continue providing power to Load 1. The power supply can provide 2-A continuous current. Load 1 consumes 1-A continuous current. The TPS22951 is used to ensure that Load 2 consumes less than 1-A continuous current. This ensures that the power supply can provide power to Load 1 even in the case that Load 2 is shorted to ground.

9.2.3 Application Curve

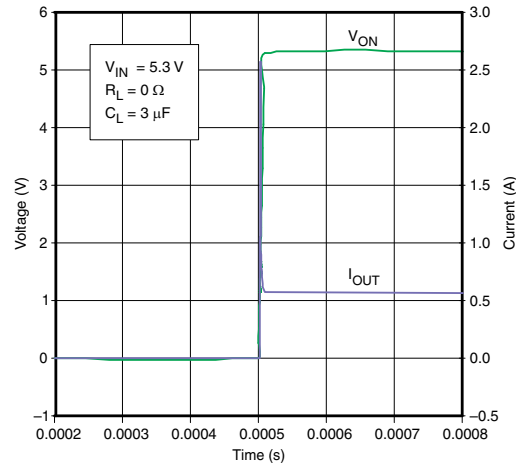

Figure 13. Device Enabled into Short-Circuit

10 Power Supply Recommendations

The device is designed to operate from a V_{CC} range of 2.8 to 5.3 V. The V_{CC} power supply must be well regulated and placed as close to the V_{CC} terminal as possible. The power supply must be able to withstand all transient load current steps. In most situations, using a small input capacitor is sufficient to prevent the supply voltage from dipping when the switch is turned on. In cases where the power supply is slow to respond to a large transient current or large load current step, additional bulk capacitance may be required on the input.

11 Layout

11.1 Layout Guidelines

- The V_{CC} and PWR traces must be wide enough to carry the necessary load current (up to 600 mA).
- To handle transient load currents, a capacitor may be placed close to the V_{CC} pin.
- To make use of the PG signal, it must be connected to a pullup resistor. The pullup source may be the V_{CC} node. It is also possible to use a different source for the pullup resistor.

11.2 Layout Example

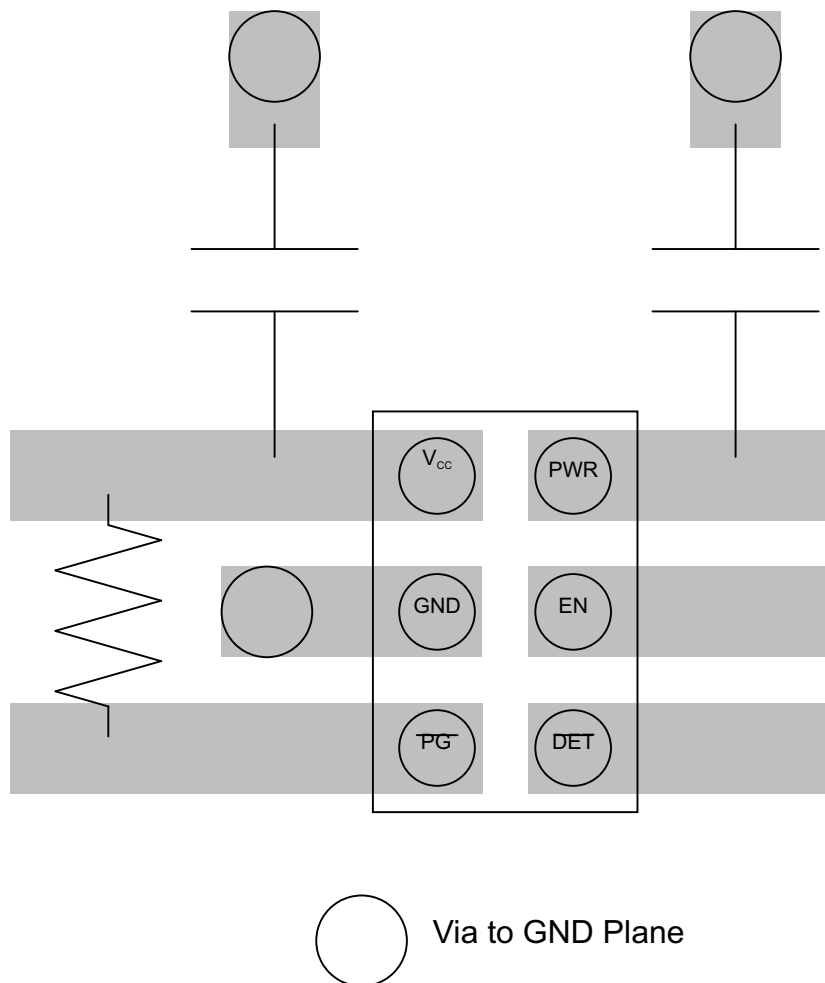

Figure 14. Layout Example

11.3 Thermal Considerations

The maximum IC junction temperature must be restricted to 85°C under normal operating conditions. To calculate the maximum allowable dissipation, $P_{D(max)}$ for a given ambient temperature, use [Equation 2](#) and [Equation 3](#).

$$P_{D(MAX)} = \frac{T_{J(MAX)} - T_A}{R_{\theta JA}}$$

where

- $P_{D(max)}$ = maximum allowable power dissipation
- $T_{J(max)}$ = maximum allowable junction temperature (85°C for the TPS22951)

Thermal Considerations (continued)

- T_A = ambient temperature of the device
- $R_{\theta JA}$ = junction to air thermal impedance. See thermal metrics table. This parameter is highly dependent upon board layout. (2)

$$P_D = I^2 \times R \quad (3)$$

12 Device and Documentation Support

12.1 Documentation Support

12.1.1 Related Documentation

For related documentation see the following:

- [Basics of Load Switches](#)
- [Load Switch Thermal Considerations](#)

12.2 Receiving Notification of Documentation Updates

To receive notification of documentation updates, navigate to the device product folder on [ti.com](#). In the upper right corner, click on *Alert me* to register and receive a weekly digest of any product information that has changed. For change details, review the revision history included in any revised document.

12.3 Community Resources

The following links connect to TI community resources. Linked contents are provided "AS IS" by the respective contributors. They do not constitute TI specifications and do not necessarily reflect TI's views; see TI's [Terms of Use](#).

TI E2E™ Online Community *TI's Engineer-to-Engineer (E2E) Community*. Created to foster collaboration among engineers. At [e2e.ti.com](#), you can ask questions, share knowledge, explore ideas and help solve problems with fellow engineers.

Design Support *TI's Design Support* Quickly find helpful E2E forums along with design support tools and contact information for technical support.

12.4 Trademarks

E2E is a trademark of Texas Instruments.

All other trademarks are the property of their respective owners.

12.5 Electrostatic Discharge Caution



This integrated circuit can be damaged by ESD. Texas Instruments recommends that all integrated circuits be handled with appropriate precautions. Failure to observe proper handling and installation procedures can cause damage.

ESD damage can range from subtle performance degradation to complete device failure. Precision integrated circuits may be more susceptible to damage because very small parametric changes could cause the device not to meet its published specifications.

12.6 Glossary

[SLYZ022](#) — *TI Glossary*.

This glossary lists and explains terms, acronyms, and definitions.

13 Mechanical, Packaging, and Orderable Information

The following pages include mechanical, packaging, and orderable information. This information is the most current data available for the designated devices. This data is subject to change without notice and revision of this document. For browser-based versions of this data sheet, refer to the left-hand navigation.

PACKAGING INFORMATION

Orderable Device	Status (1)	Package Type	Package Drawing	Pins	Package Qty	Eco Plan (2)	Lead finish/ Ball material (6)	MSL Peak Temp (3)	Op Temp (°C)	Device Marking (4/5)	Samples
TPS22951YFPR	ACTIVE	DSBGA	YFP	6	3000	RoHS & Green	SNAGCU	Level-1-260C-UNLIM	-40 to 85	(2W, 2W7)	Samples

(1) The marketing status values are defined as follows:

ACTIVE: Product device recommended for new designs.

LIFEBUY: TI has announced that the device will be discontinued, and a lifetime-buy period is in effect.

NRND: Not recommended for new designs. Device is in production to support existing customers, but TI does not recommend using this part in a new design.

PREVIEW: Device has been announced but is not in production. Samples may or may not be available.

OBSELETE: TI has discontinued the production of the device.

(2) **RoHS:** TI defines "RoHS" to mean semiconductor products that are compliant with the current EU RoHS requirements for all 10 RoHS substances, including the requirement that RoHS substance do not exceed 0.1% by weight in homogeneous materials. Where designed to be soldered at high temperatures, "RoHS" products are suitable for use in specified lead-free processes. TI may reference these types of products as "Pb-Free".

RoHS Exempt: TI defines "RoHS Exempt" to mean products that contain lead but are compliant with EU RoHS pursuant to a specific EU RoHS exemption.

Green: TI defines "Green" to mean the content of Chlorine (Cl) and Bromine (Br) based flame retardants meet JS709B low halogen requirements of <=1000ppm threshold. Antimony trioxide based flame retardants must also meet the <=1000ppm threshold requirement.

(3) MSL, Peak Temp. - The Moisture Sensitivity Level rating according to the JEDEC industry standard classifications, and peak solder temperature.

(4) There may be additional marking, which relates to the logo, the lot trace code information, or the environmental category on the device.

(5) Multiple Device Markings will be inside parentheses. Only one Device Marking contained in parentheses and separated by a "-" will appear on a device. If a line is indented then it is a continuation of the previous line and the two combined represent the entire Device Marking for that device.

(6) Lead finish/Ball material - Orderable Devices may have multiple material finish options. Finish options are separated by a vertical ruled line. Lead finish/Ball material values may wrap to two lines if the finish value exceeds the maximum column width.

Important Information and Disclaimer:The information provided on this page represents TI's knowledge and belief as of the date that it is provided. TI bases its knowledge and belief on information provided by third parties, and makes no representation or warranty as to the accuracy of such information. Efforts are underway to better integrate information from third parties. TI has taken and continues to take reasonable steps to provide representative and accurate information but may not have conducted destructive testing or chemical analysis on incoming materials and chemicals. TI and TI suppliers consider certain information to be proprietary, and thus CAS numbers and other limited information may not be available for release.

In no event shall TI's liability arising out of such information exceed the total purchase price of the TI part(s) at issue in this document sold by TI to Customer on an annual basis.

TAPE AND REEL INFORMATION

QUADRANT ASSIGNMENTS FOR PIN 1 ORIENTATION IN TAPE

*All dimensions are nominal

Device	Package Type	Package Drawing	Pins	SPQ	Reel Diameter (mm)	Reel Width W1 (mm)	A0 (mm)	B0 (mm)	K0 (mm)	P1 (mm)	W (mm)	Pin1 Quadrant
TPS22951YFPR	DSBGA	YFP	6	3000	177.8	8.4	0.9	1.3	0.6	4.0	8.0	Q1

TAPE AND REEL BOX DIMENSIONS

*All dimensions are nominal

Device	Package Type	Package Drawing	Pins	SPQ	Length (mm)	Width (mm)	Height (mm)
TPS22951YFPR	DSBGA	YFP	6	3000	220.0	220.0	34.0

YFP0006



PACKAGE OUTLINE

DSBGA - 0.5 mm max height

DIE SIZE BALL GRID ARRAY

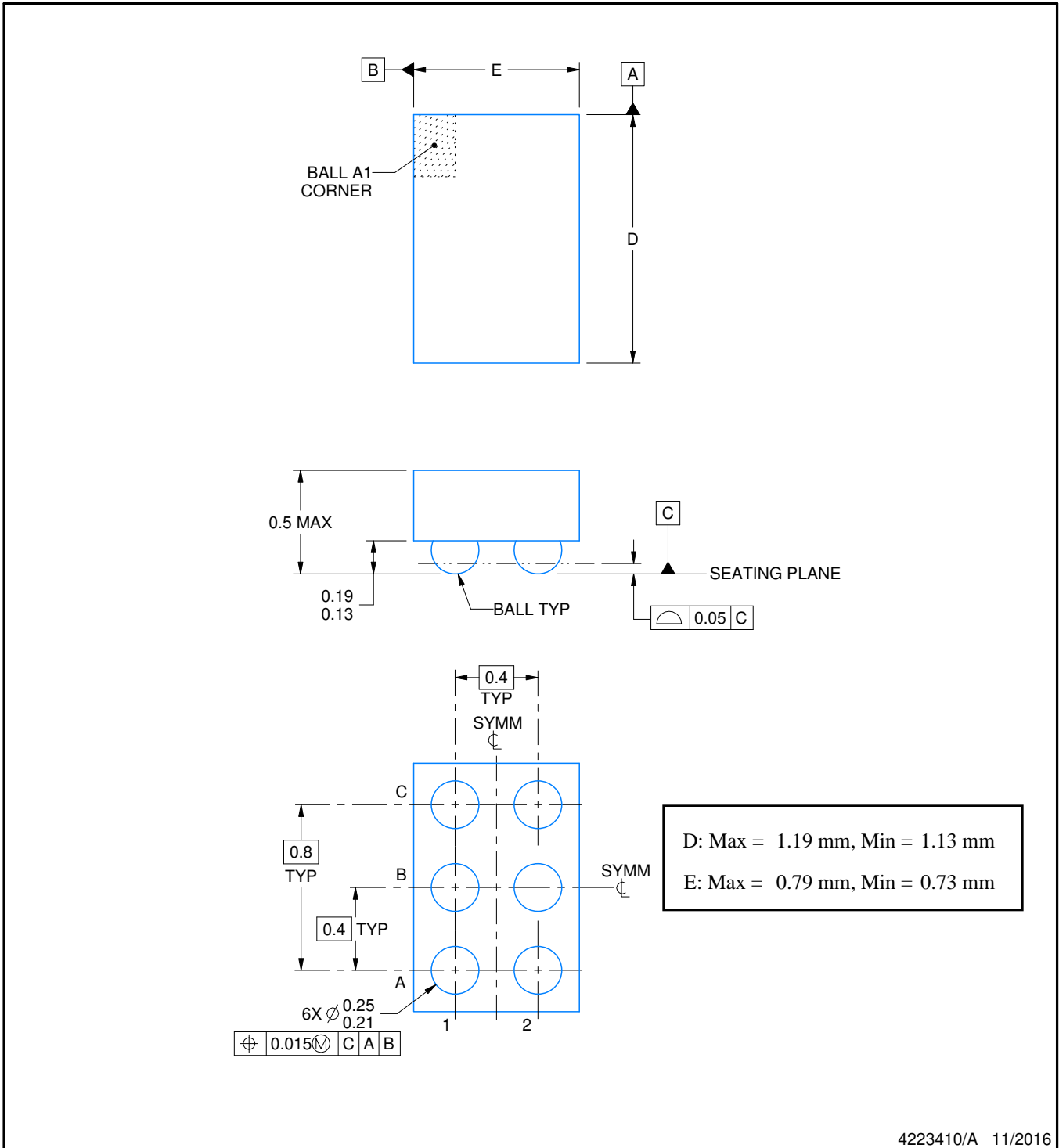

4223410/A 11/2016

NOTES:

1. All linear dimensions are in millimeters. Any dimensions in parenthesis are for reference only. Dimensioning and tolerancing per ASME Y14.5M.
2. This drawing is subject to change without notice.

EXAMPLE BOARD LAYOUT

YFP0006

DSBGA - 0.5 mm max height

DIE SIZE BALL GRID ARRAY

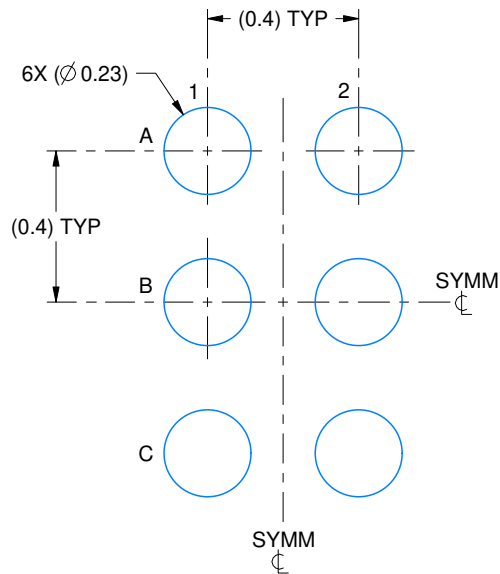

LAND PATTERN EXAMPLE
SCALE:50X

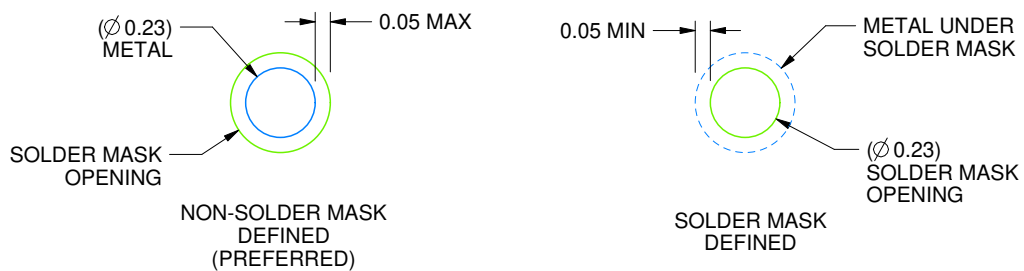

SOLDER MASK DETAILS
NOT TO SCALE

4223410/A 11/2016

NOTES: (continued)

- Final dimensions may vary due to manufacturing tolerance considerations and also routing constraints. For more information, see Texas Instruments literature number SNVA009 (www.ti.com/lit/snva009).

EXAMPLE STENCIL DESIGN

YFP0006

DSBGA - 0.5 mm max height

DIE SIZE BALL GRID ARRAY

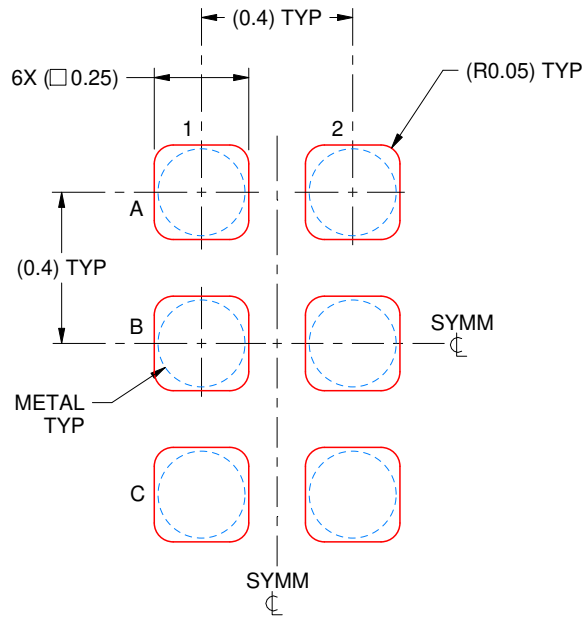

SOLDER PASTE EXAMPLE
BASED ON 0.1 mm THICK STENCIL
SCALE:50X

4223410/A 11/2016

NOTES: (continued)

4. Laser cutting apertures with trapezoidal walls and rounded corners may offer better paste release.

IMPORTANT NOTICE AND DISCLAIMER

TI PROVIDES TECHNICAL AND RELIABILITY DATA (INCLUDING DATA SHEETS), DESIGN RESOURCES (INCLUDING REFERENCE DESIGNS), APPLICATION OR OTHER DESIGN ADVICE, WEB TOOLS, SAFETY INFORMATION, AND OTHER RESOURCES "AS IS" AND WITH ALL FAULTS, AND DISCLAIMS ALL WARRANTIES, EXPRESS AND IMPLIED, INCLUDING WITHOUT LIMITATION ANY IMPLIED WARRANTIES OF MERCHANTABILITY, FITNESS FOR A PARTICULAR PURPOSE OR NON-INFRINGEMENT OF THIRD PARTY INTELLECTUAL PROPERTY RIGHTS.

These resources are intended for skilled developers designing with TI products. You are solely responsible for (1) selecting the appropriate TI products for your application, (2) designing, validating and testing your application, and (3) ensuring your application meets applicable standards, and any other safety, security, regulatory or other requirements.

These resources are subject to change without notice. TI grants you permission to use these resources only for development of an application that uses the TI products described in the resource. Other reproduction and display of these resources is prohibited. No license is granted to any other TI intellectual property right or to any third party intellectual property right. TI disclaims responsibility for, and you will fully indemnify TI and its representatives against, any claims, damages, costs, losses, and liabilities arising out of your use of these resources.

TI's products are provided subject to [TI's Terms of Sale](#) or other applicable terms available either on [ti.com](https://www.ti.com) or provided in conjunction with such TI products. TI's provision of these resources does not expand or otherwise alter TI's applicable warranties or warranty disclaimers for TI products.

TI objects to and rejects any additional or different terms you may have proposed.

Mailing Address: Texas Instruments, Post Office Box 655303, Dallas, Texas 75265
Copyright © 2023, Texas Instruments Incorporated