

PRODUCT NUMBER	1X4 EXTERNAL ASSEMBLY	1X4 LIGHT PIPE SUB-ASSEMBLY WITH MOUNTING CLIP
10130603-101LF	10112628-101LF	10130602-001LF

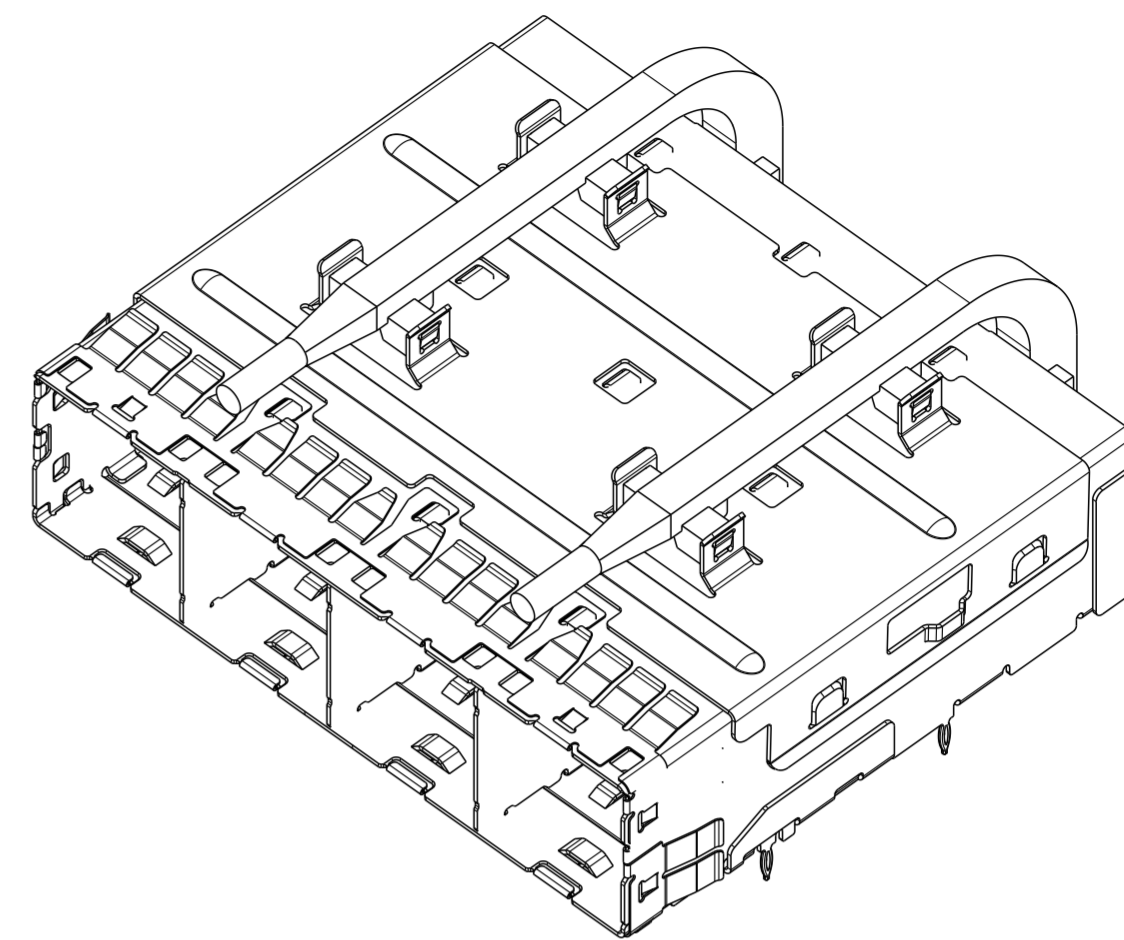

10130603-101LF
WITH LIGHT PIPES

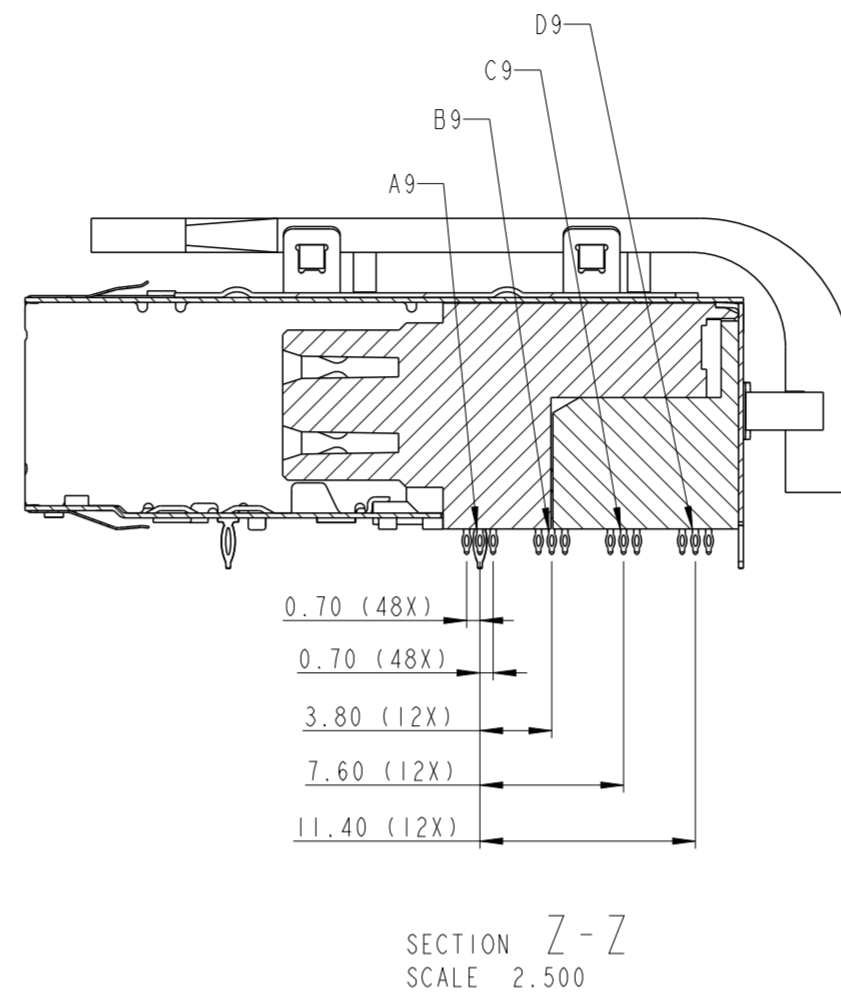
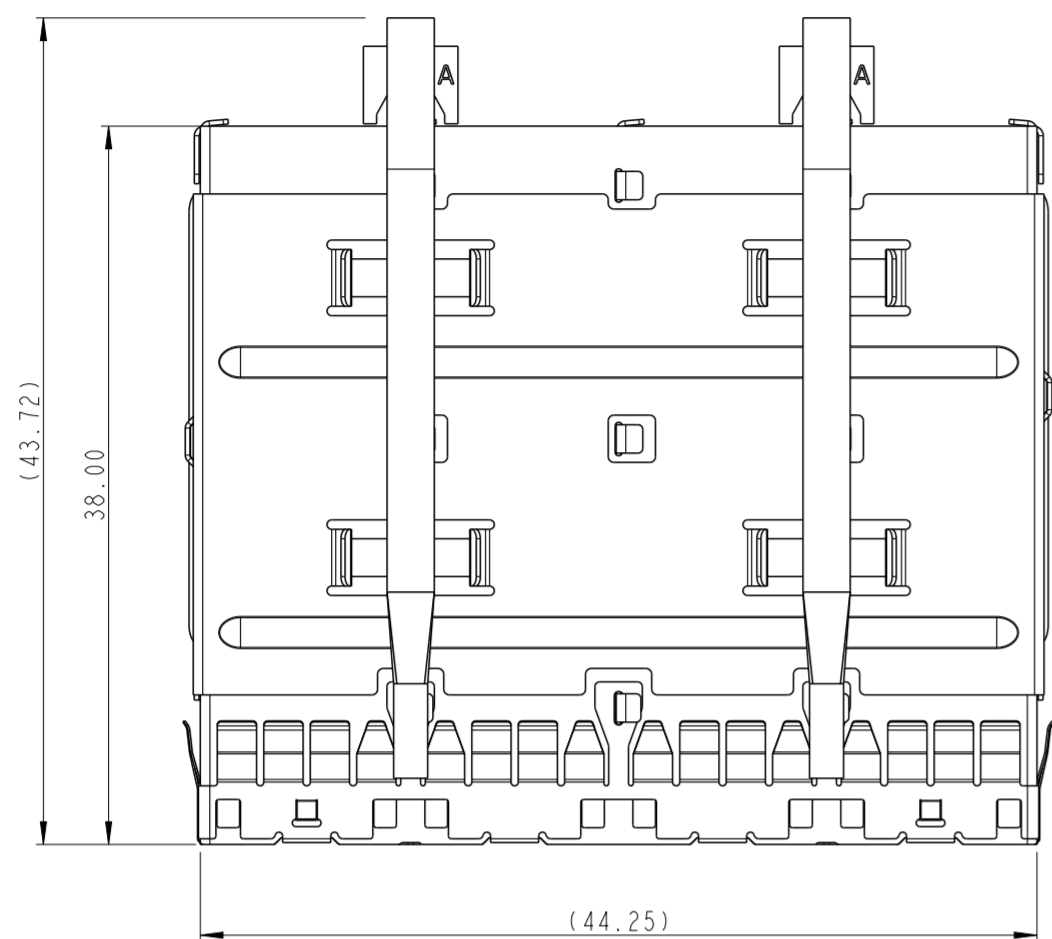
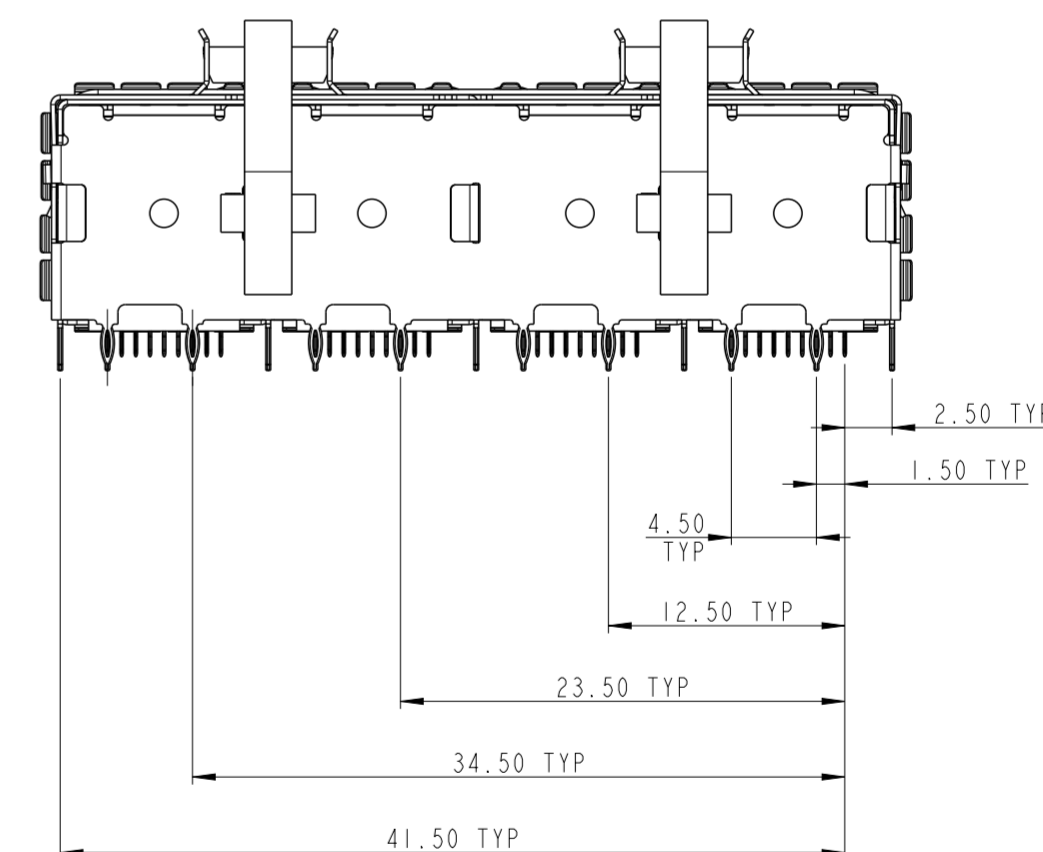
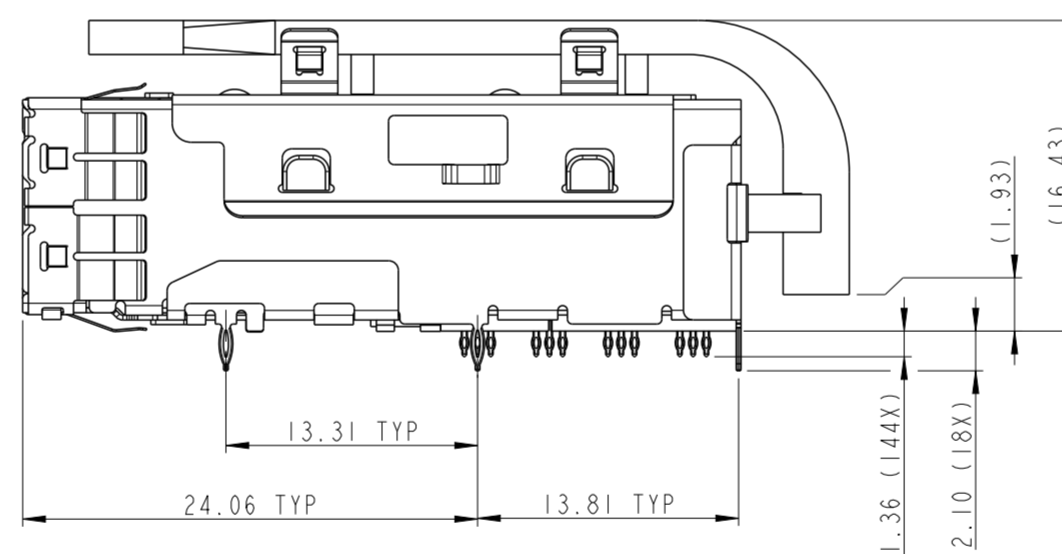
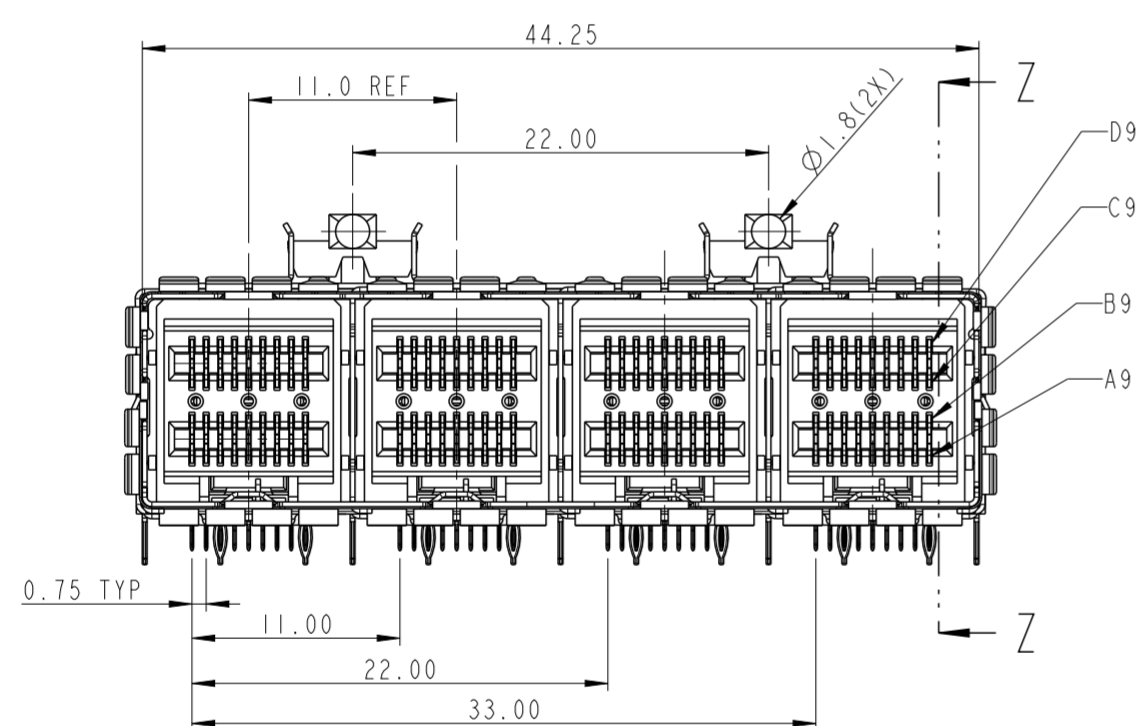

NOTES:

- MATERIALS:
CONNECTOR HOUSING: HIGH TEMPERATURE THERMOPLASTIC
GLASS FILLED, UL 94V-0
EMI CAGE: NICKEL SILVER ALLOY
EMI FINGERS: COPPER ALLOY
TERMINALS: COPPER ALLOY
LIGHT PIPE CLIP: STAINLESS STEEL
LIGHT PIPE: POLYCARBONATE
- FINISHES:
EMI FINGERS: 0.50um NICKEL
CONTACT AREA: 0.76um GOLD OVER 2.54um NICKEL
CONTACT TAIL AREA: 0.76um - 1.52um TIN OVER 2.54um NICKEL
- PRODUCT SPECIFICATION: GS-12-651
- PRODUCT PACKING SPECIFICATION: GS-14-1490
EXTERNAL ASSEMBLY WILL BE IN ONE BOX.
LIGHT PIPE SUB-ASSEMBLY WITH MOUNTING CLIP WILL BE IN ONE BOX.
BOTH BOXES WILL BE IN A MASTER CARTON.
- APPLICATION SPECIFICATION: GS-20-0327
- MOUNTING HARDWARE: M2X0.4 BUTTON HEAD SCREW
MOUNTING SCREW LENGTH: BOARD THICKNESS + 1.4mm MAX (0.9mm MIN).
4 REQUIRED PER ASSEMBLY.
MOUNTING HARDWARE NOT SUPPLIED.
- THIS CONNECTOR IS DESIGNED TO MEET THE REQUIREMENTS OF INDUSTRY SPECIFICATION SFF-8644.
- LIGHT PIPE SUB-ASSEMBLY WITH MOUNTING CLIP FINAL ASSEMBLY AFTER EXTERNAL ASSEMBLY APPLIED TO PCB.

MATES WITH
MINI-SAS HD ENDS IN:

10112041 SERIES (4X)
10117771 SERIES (4X)
10117946 SERIES (4X)
10117949 SERIES (4X)
10117947 SERIES (8X)
10112359 SERIES (8X)
10117950 SERIES (8X)
10117948 SERIES (8X)

spec ref	-	dr	Jackbin Zou	2014/07/10	projection	MM	size	A2	scale	5:2	
tolerance std	ISO 406 ISO 1101	eng	Jackbin Zou	2014/12/18			ecn no	-	rel level	Released	
surface	linear	chr	-	app							Collins Lu
	angular	0°	±0.5 ±0.3 ±0.25	0°	±3°	www.fci.com	cat. no.	-	Product - Customer Drw	sheet 1 of 6	
							title	1x4 EXTERNAL ASSEMBLY WITH LIGHT PIPE MINI-SAS HD		rev	A
							dwg no	10130603		rev	



Copyright FCI.

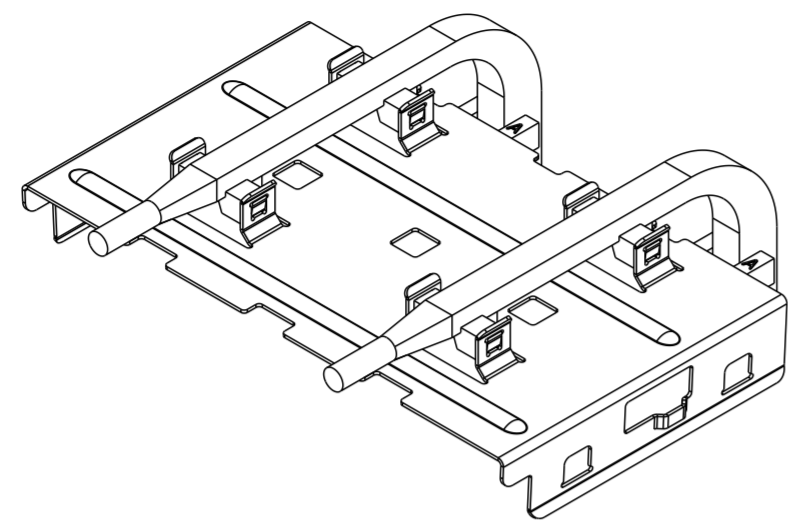

1X4 LIGHT PIPE SUB-ASSEMBLY
WITH MOUNTING CLIP
10130602-001LF

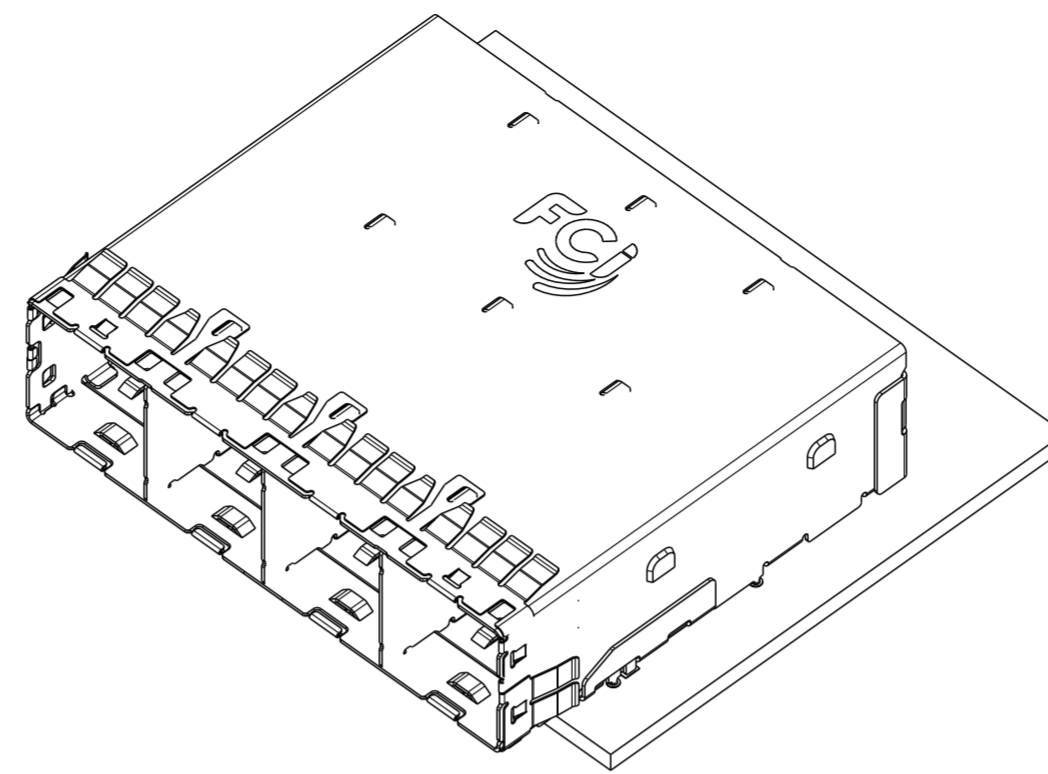

1X4 EXTERNAL ASSEMBLY
APPLIED TO PCB
10112628-101LF

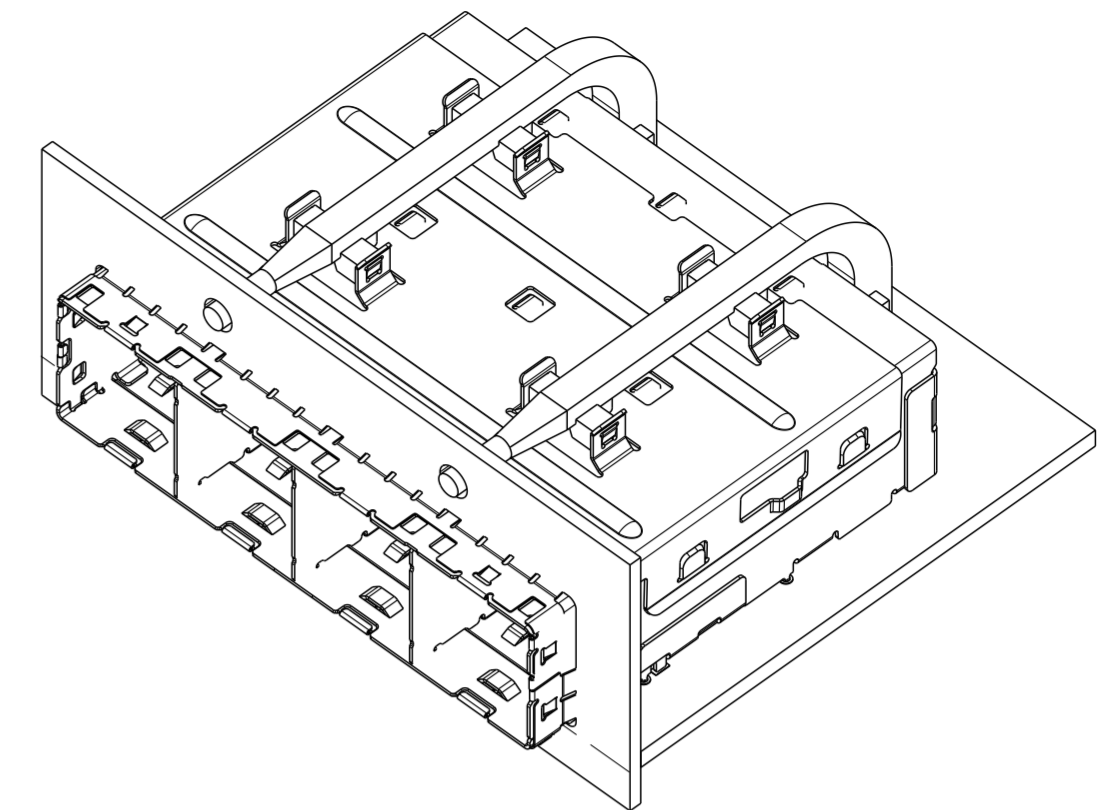

SCALE 2.000

10130603-101LF
WITH LIGHT PIPES
(LIGHT PIPE SUB-ASSEMBLY
WITH MOUNTING CLIP FINAL
ASSEMBLY BY CUSTOMER)

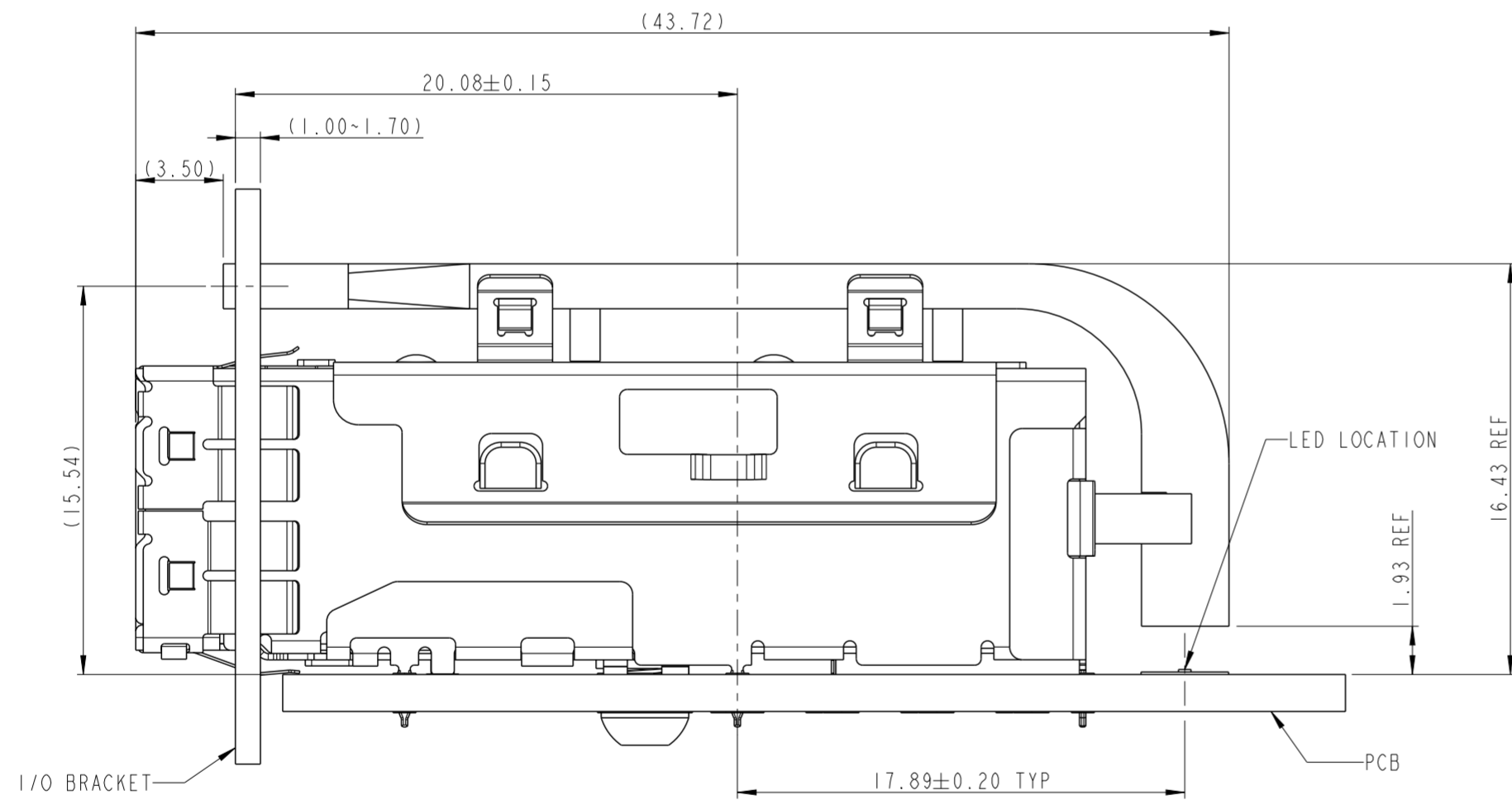

ASSEMBLED VIEW
WITH LIGHT PIPES
SCALE 4:1

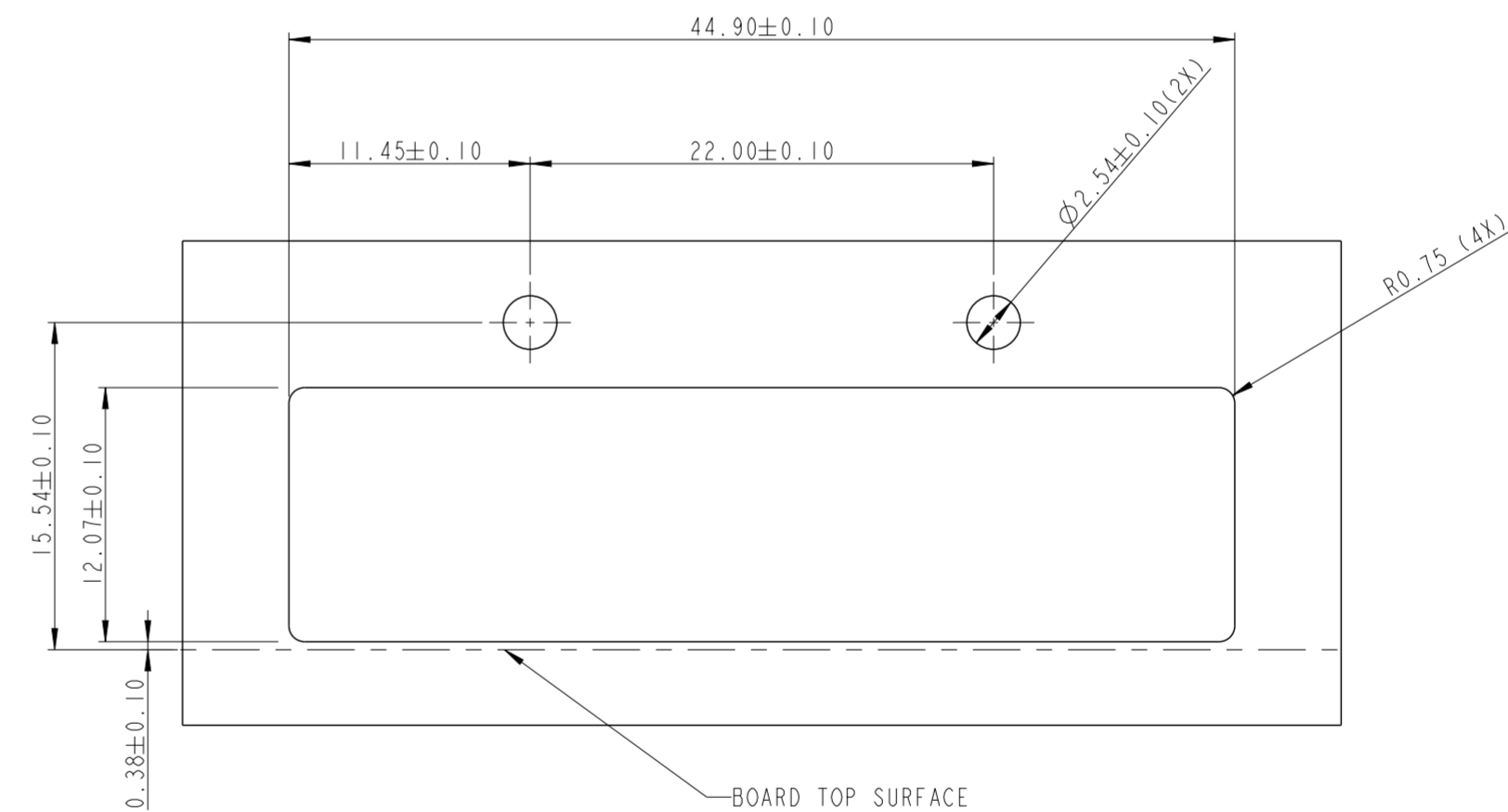

SCALE 3.000

I/O BRACKET CUT OUT
(BRACKET NOT SUPPLIED)

spec ref	-	dr	Jackbin Zou	2014/07/10	projection	MM	size	A2	scale	4:1
tolerance std	ISO 406 ISO 1101	eng	Jackbin Zou	2014/12/18			ecn no	-	Released	rev A
TOLERANCES UNLESS OTHERWISE SPECIFIED		chr	-	product family			-	rel level		
surface	ISO 1302	appr	Collins Lu	2014/12/18			title 1x4 EXTERNAL ASSEMBLY WITH LIGHT PIPE MINI-SAS HD	dwg no 10130603	Product - Customer Draw	sheet 2 of 6
	linear	0.X	±0.5							
		0.XX	±0.3							
		0.XXX	±0.25							
	angular	0°	±3°							

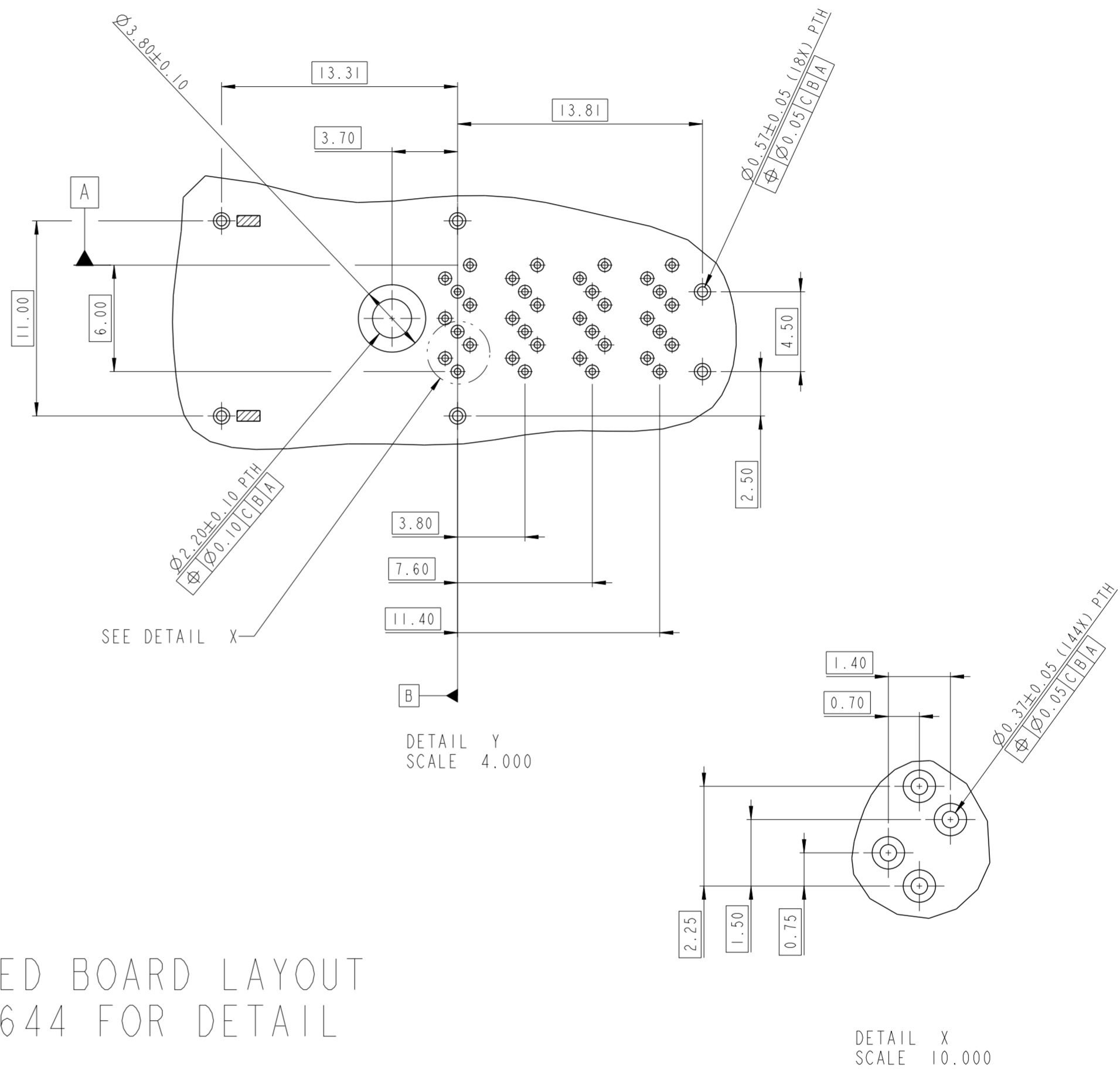
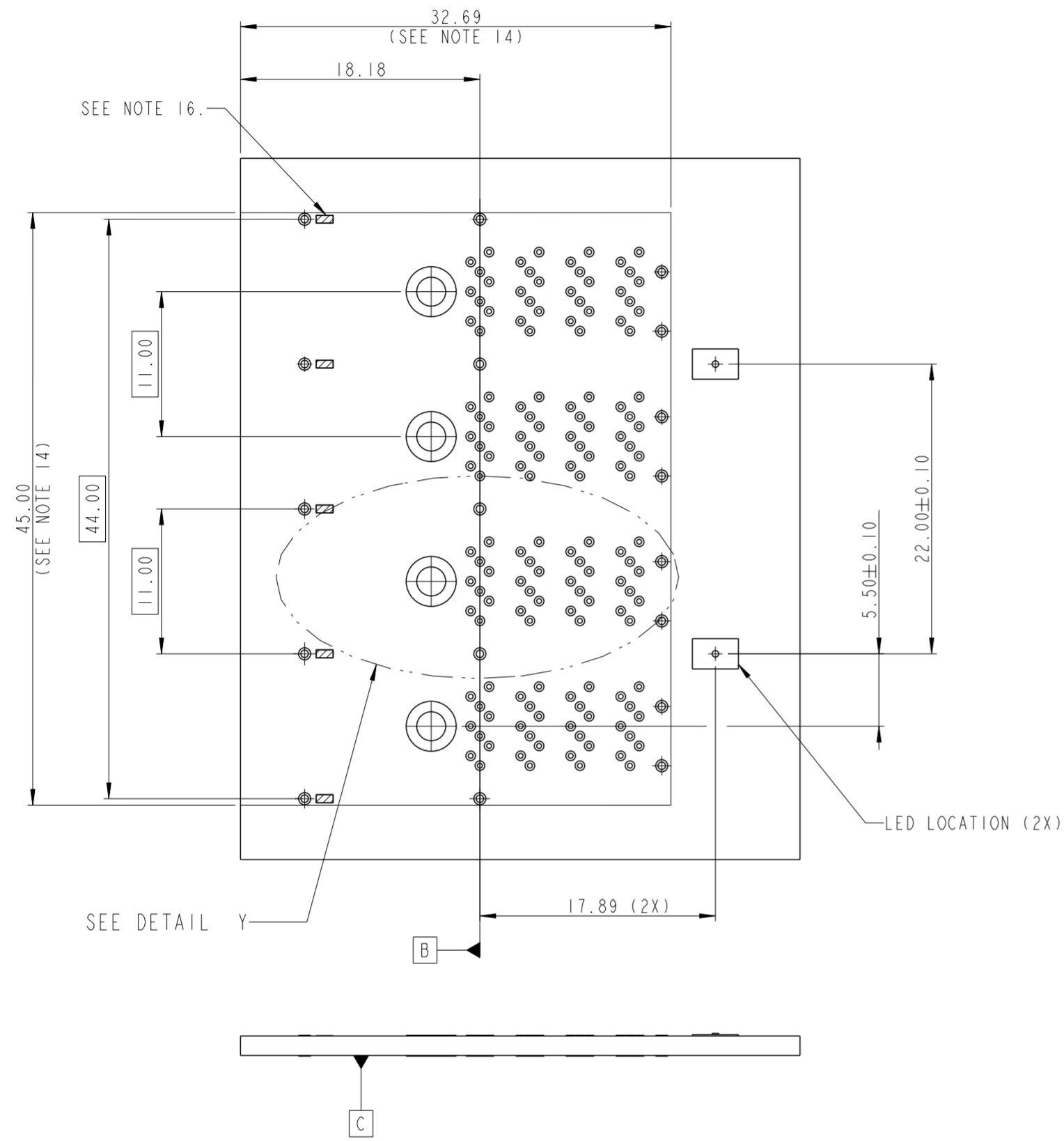

RECOMMENDED BOARD LAYOUT
SEE SFF-8644 FOR DETAIL

- NOTES:
9. RECOMMENDED DRILL SIZE FOR Ø0.37 FINISHED PTH IS Ø0.457.
 10. RECOMMENDED ANNULAR RING AROUND Ø0.37 FINISHED PTH IS Ø0.73.
 11. RECOMMENDED DRILL SIZE FOR Ø0.57 FINISHED PTH IS Ø0.68.
 12. RECOMMENDED ANNULAR RING AROUND Ø0.57 FINISHED PTH IS Ø0.93.
 13. MINIMUM RECOMMENDED CENTER TO CENTER SPACING BETWEEN ADJACENT CONNECTORS: 47.00mm.
 14. CONNECTOR KEEP OUT AREA.
 15. MINIMUM PCB THICKNESS: 1.57mm.
 16. CAGE STAND OFF AREA, NO TRACES ON SURFACE OF PCB IN THE AREAS.

spec ref	-	dr	Jackbin Zou	2014/07/10	projection	MM	size	A2	scale	5:2
tolerance std	ISO 406 ISO 1101	eng	Jackbin Zou	2014/12/18			ecn no	-	rel level	Released
surface	✓	chr	-	appr						
linear	0.X ±0.5 0.XX ±0.3 0.XXX ±0.25			title 1x4 EXTERNAL ASSEMBLY WITH LIGHT PIPE MINI-SAS HD		dwg no 10130603	rev A	ISO 1302 angular 0° ±3°		
www.fci.com		cat. no.		-		Product - Customer Drw		sheet 3 of 6		

PDS: Rev :A

STATUS:Released

Printed: Dec 18, 2014

Copyright FCI. FCI

RECOMMENDED KEEP OUT AREAS

RECOMMENDED INSERTION TOOL
KEEP OUT AREA
NO COMPONENTS IN THIS AREA
MORE THAN 7.50mm TALL

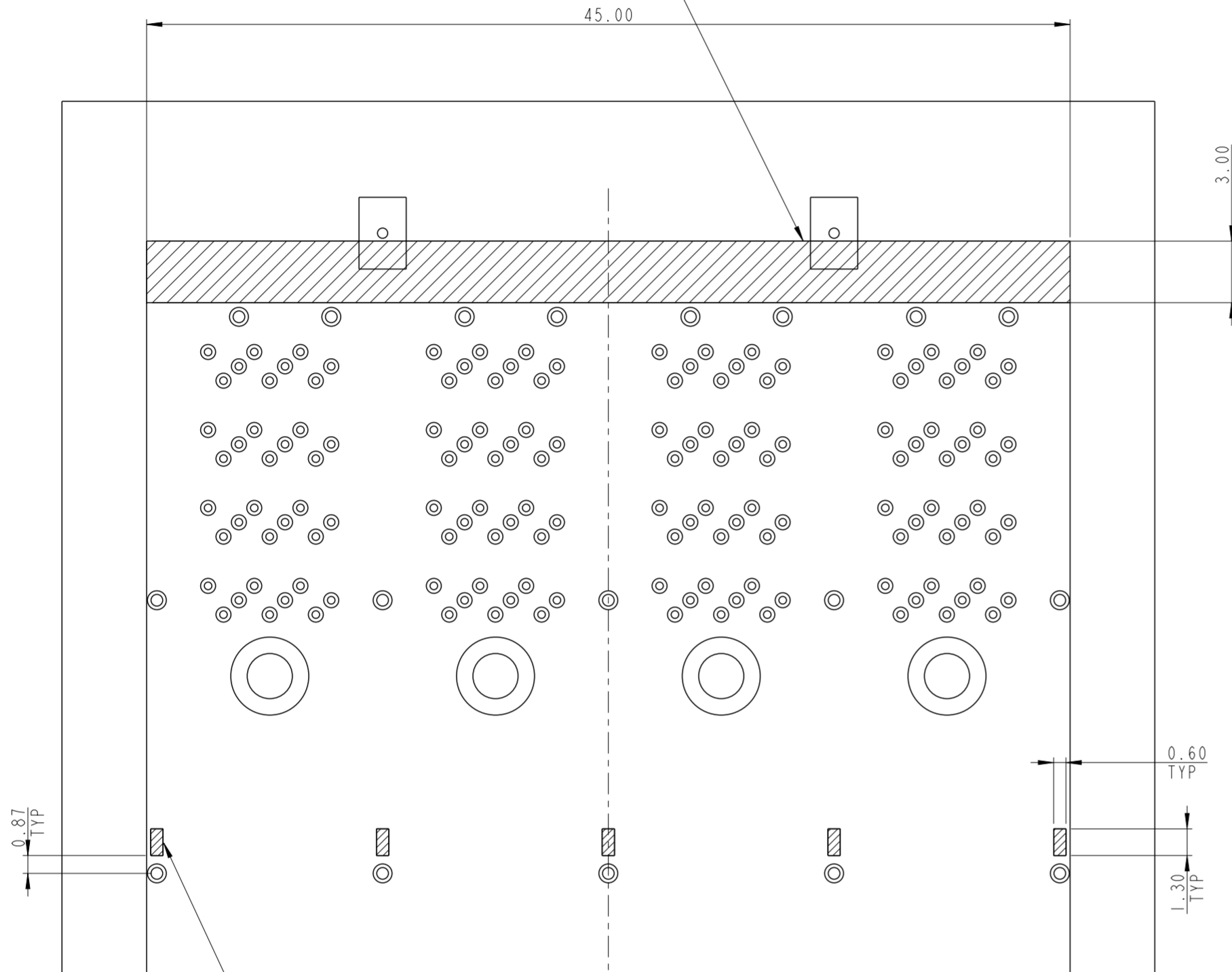

CAGE STAND OFF KEEP OUT AREA

RECOMMENDED EXTRACTION TOOL
KEEP OUT AREA
NO COMPONENTS IN THESE AREAS

RECOMMENDED EXTRACTION TOOL
KEEP OUT AREA
NO COMPONENTS IN THESE AREAS

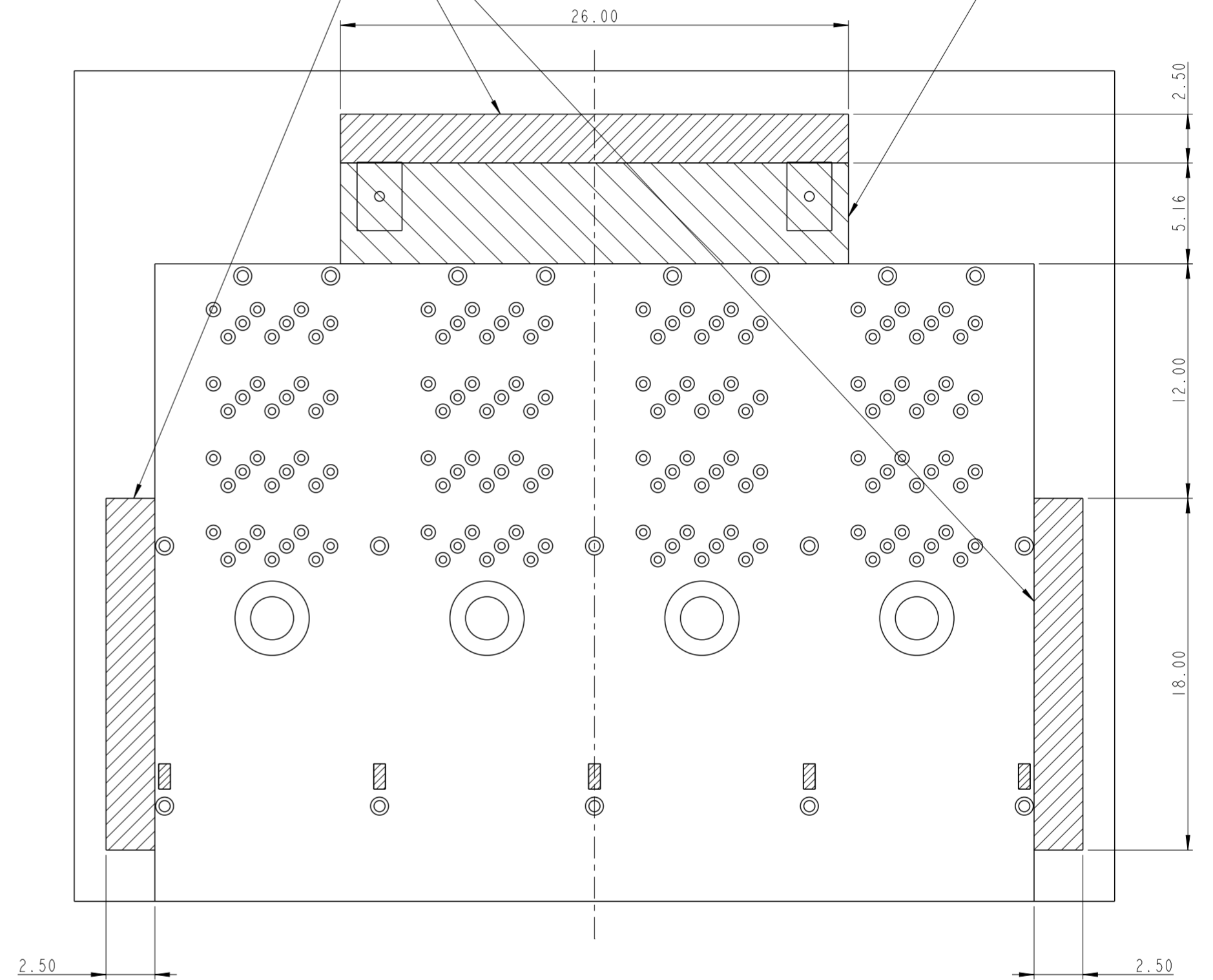

Copyright FCI.

spec ref	-	dr	Jackbin Zou	2014/07/10	projection	MM	size	A2	scale	4:1
tolerance std	ISO 406 ISO 1101	eng	Jackbin Zou	2014/12/18			ecn no	-	Released	sheet 4 of 6
TOLERANCES UNLESS OTHERWISE SPECIFIED		chr	-	appr			Collins Lu	2014/12/18		
surface	ISO 1302	linear	0.X	±0.5			title	1x4 EXTERNAL ASSEMBLY WITH LIGHT PIPE		dwg no 10130603
			0.XX	±0.3	www.fci.com		cat. no.	-	Product - Customer Drw	
		angular	0°	±3°	PDS: Rev :A			STATUS:Released	Printed: Dec 18, 2014	

PIN OUT DESIGNATIONS

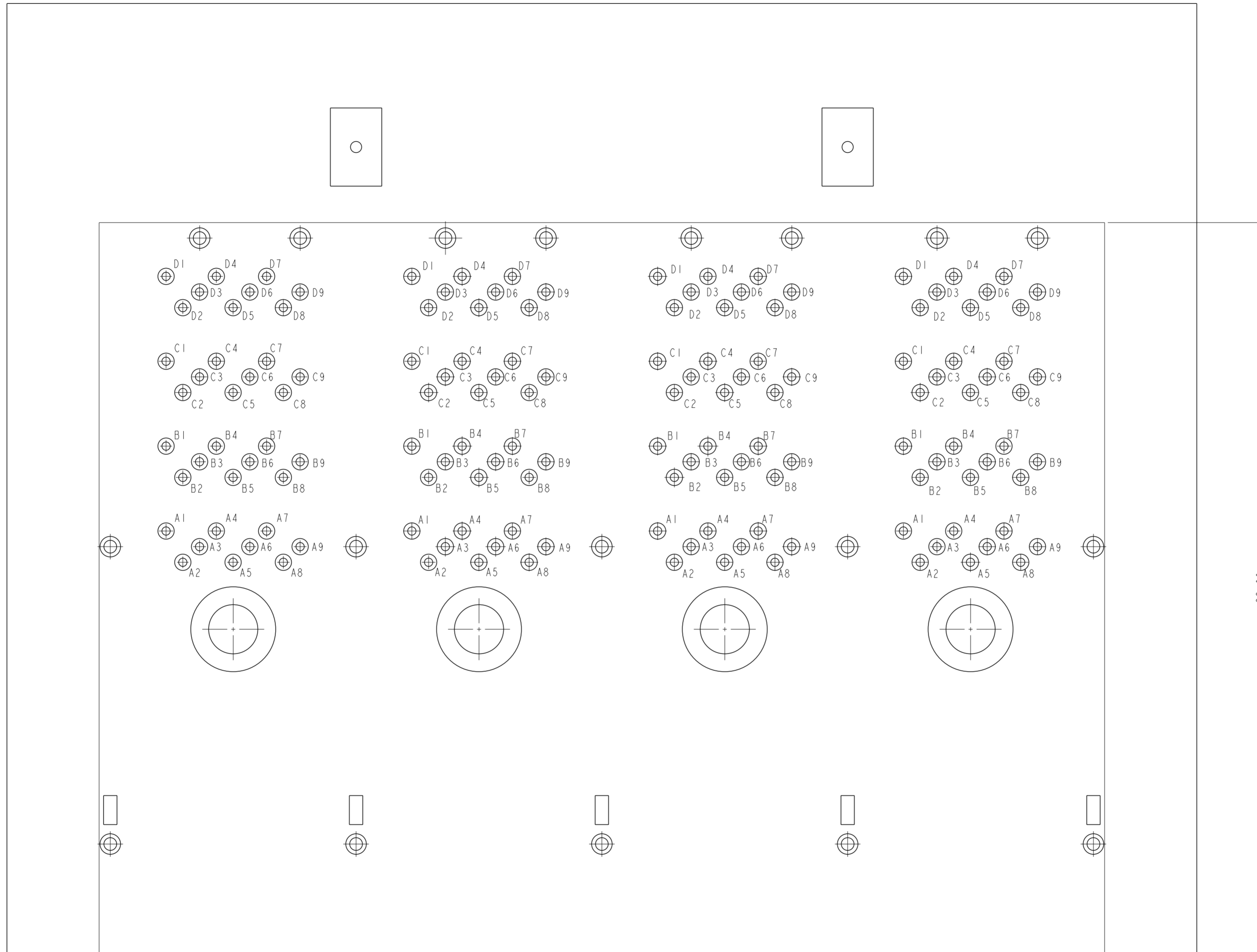

32.69



Copyright FCJ.

spec ref	-	dr	Jackbin Zou	2014/07/10	projection	MM	size	A2	scale	7:1
tolerance std	ISO 406 ISO 1101	eng	Jackbin Zou	2014/12/18			ecn no	-	rel level	
TOLERANCES UNLESS OTHERWISE SPECIFIED		chr	-	rel level			Released			
surface	ISO 1302	appr	Collins Lu	2014/12/18	product family	-	cat. no.	10130603	rev	A
	linear	0.X	±0.5							
		0.XX	±0.3							
		0.XXX	±0.25							
	angular	0°	±3°							

PDS: Rev :A

STATUS:Released

Printed: Dec 18, 2014

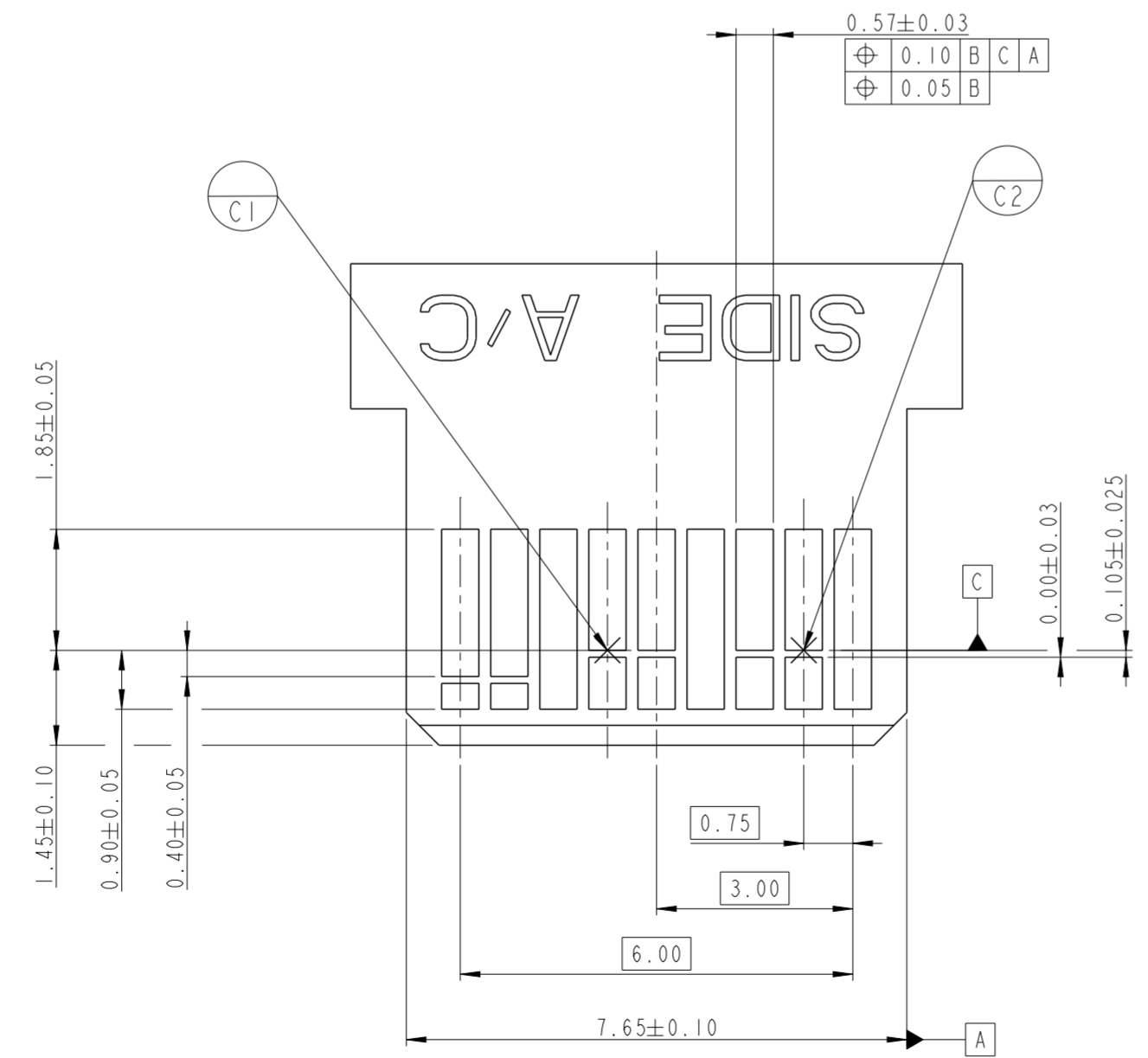
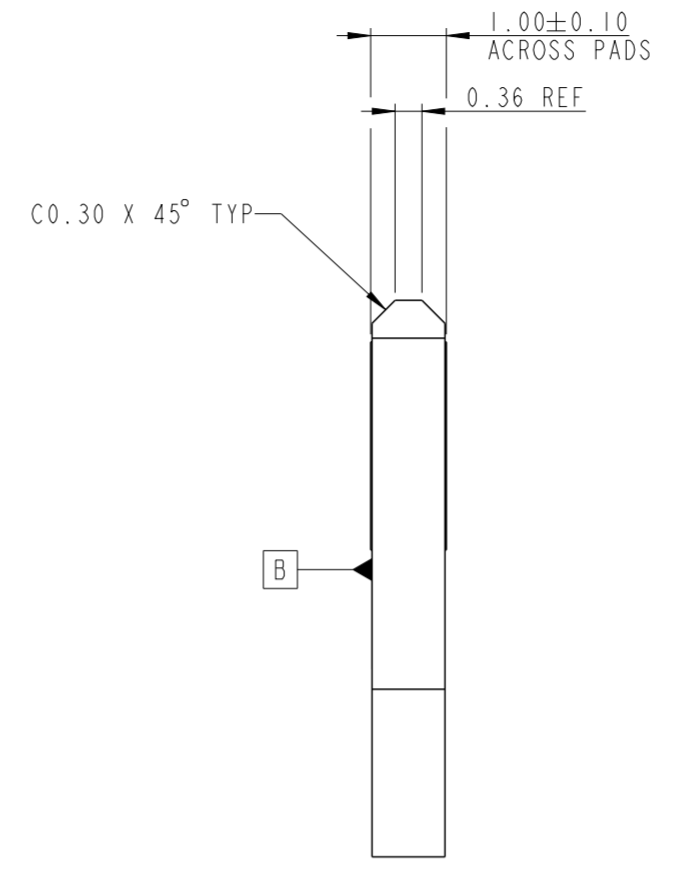
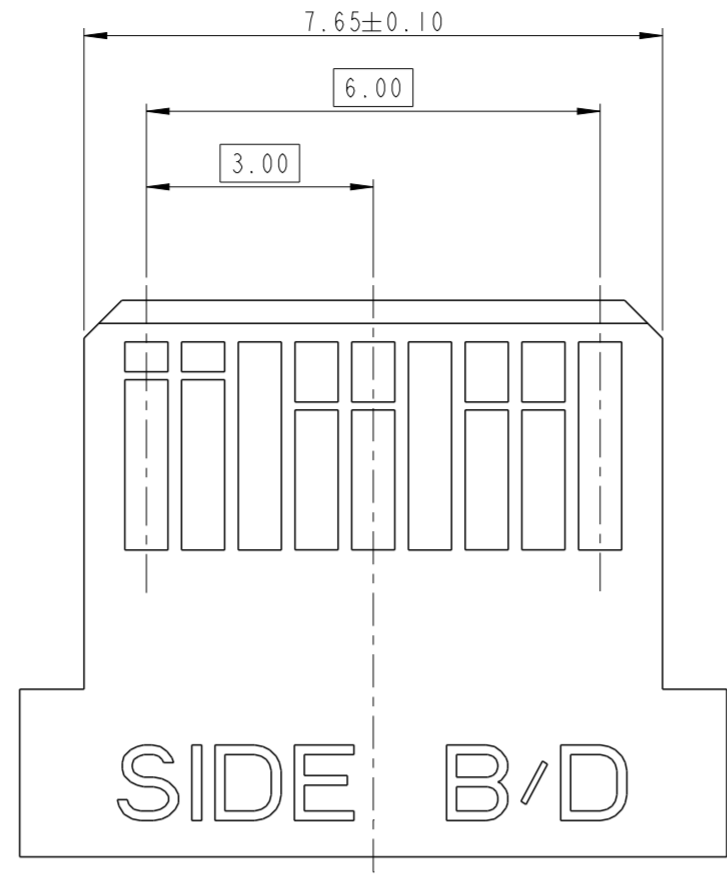

RECOMMENDED PLUG PADDLE CARD
SEE SFF-8644 FOR DETAIL

- NOTES:
- 17. 0.05 MINIMUM KEEP OUT FOR SOLDER MASK AROUND ALL PADS.
 - 18. DATUM C TARGETS ARE DEFINED BY THE RESPECTIVE PAD CENTER LINES AND THE LEADING EDGE OF THE TARGET PADS.

spec ref	-	dr	Jackbin Zou	2014/07/10	projection	MM	size	A2	scale	10:1
tolerance std	ISO 406 ISO 1101	eng	Jackbin Zou	2014/12/18			ecn no	-	rel level	
surface	ISO 1302	chr	-	appr			Collins Lu	2014/12/18	product family	-
linear	0.X ±0.5 0.XX ±0.3 0.XXX ±0.25	angular	0° ±3°			title 1x4 EXTERNAL ASSEMBLY WITH LIGHT PIPE MINI-SAS HD	dwg no 10130603	rev A	Product - Customer Drw sheet 6 of 6	

Copyright FCI.