

High Speed, Monolithic D/A Converter with Reference

The HI-565A is a fast, 12-bit, current output, digital-to-analog converter. The monolithic chip includes a precision voltage reference, thin-film R2R ladder, reference control amplifier and twelve high speed bipolar current switches.

The Harris dielectric isolation process provides latch free operation while minimizing stray capacitance and leakage currents, to produce an excellent combination of speed and accuracy. Also, ground currents are minimized to produce a low and constant current through the ground terminal, which reduces error due to code dependent ground currents.

HI-565A dice are laser trimmed for a maximum integral nonlinearity error of ± 0.5 LSB at 25°C. In addition, the low noise buried zener reference is trimmed both for absolute value and temperature coefficient. Power dissipation is typically 250mW, with ± 15 V supplies.

The HI-565A is offered in both commercial and military grades. See Ordering Information.

Features

- 12-Bit DAC and Reference on a Single Chip
- Pin Compatible With AD565A
- Very High Speed: Settles to ± 0.5 LSB in 250ns (Max) Full Scale Switching Time 30ns (Typ)
- Guaranteed For Operation With ± 12 V Supplies
- Monotonicity Guaranteed Over Temperature
- Nonlinearity Guaranteed Over Temp (Max) ± 0.5 LSB
- Low Gain Drift (Max, DAC Plus Ref)25ppm/°C
- Low Power Dissipation250mW

Applications

- CRT Displays
- High Speed A/D Converters
- Signal Reconstruction
- Waveform Synthesis

Ordering Information

PART NUMBER	LINEARITY (INL)	LINEARITY (DNL)	TEMP. RANGE (°C)	PACKAGE	PKG. NO.
HI1-565AJD-5	0.50 LSB	0.75 LSB	0 to 75	24 Ld SBDIP	D24.6
HI1-565AKD-5	0.25 LSB	0.50 LSB	0 to 75	24 Ld SBDIP	D24.6
HI1-565ASD-2	0.50 LSB	0.75 LSB	-55 to 125	24 Ld SBDIP	D24.6
HI1-565ATD-2	0.25 LSB	0.50 LSB	-55 to 125	24 Ld SBDIP	D24.6
HI1-565ASD/883	0.50 LSB	0.50 LSB	-55 to 125	24 Ld SBDIP	D24.6
HI1-565ATD/883	0.25 LSB	0.50 LSB	-55 to 125	24 Ld SBDIP	D24.6

Pinout

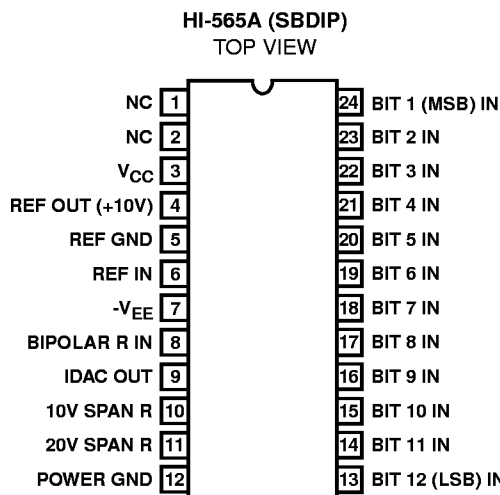

Functional Diagram

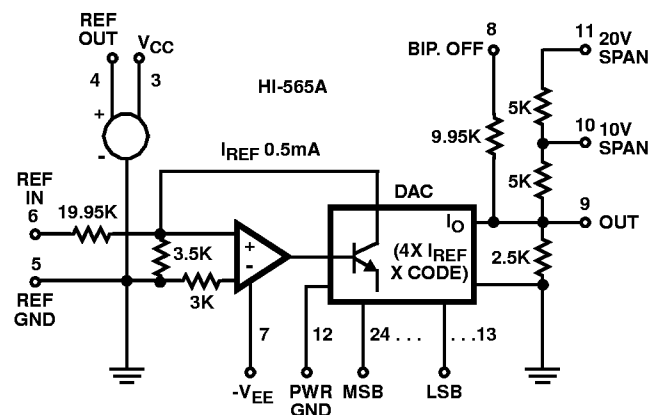

HI-565A

Absolute Maximum Ratings

V _{CC} to Power GND	0V to +18V
V _{EE} to Power GND	0V to -18V
Voltage on DAC Output (Pin 9)	-3V to +12V
Digital Inputs (Pins 13-24) to Power GND	-1V to +7.0V
REF In to REF GND	±12V
Bipolar Offset to REF GND	±12V
10V Span R to REF GND	±12V
20V Span R to REF GND	±24V
REF Out	Indefinite Short to Power GND
Momentary Short to V _{CC}	

Operating Conditions

Temperature Ranges	
HI-565AS, T-2	-55°C to 125°C
H1-565AJ, K-5	0°C to 75°C

CAUTION: Stresses above those listed in "Absolute Maximum Ratings" may cause permanent damage to the device. This is a stress only rating and operation of the device at these or any other conditions above those indicated in the operational sections of this specification is not implied.

NOTE:

1. θ_{JA} is measured with the component mounted on an evaluation PC board in free air.

Thermal Information

Thermal Resistance (Typical, Note 1)	θ_{JA} (°C/W)	θ_{JC} (°C/W)
SBDIP Package	75	30
Maximum Package Power Dissipation		
SBDIP Package		500mW
Maximum Junction Temperature		175°C
Maximum Storage Temperature Range		-65°C to 150°C
Maximum Lead Temperature (Soldering 10s)		300°C

Die Characteristics

Transistor Count	200
Process	Bipolar-DI

Electrical Specifications $T_A = 25^\circ\text{C}$, $V_{CC} = +15\text{V}$, $V_{EE} = -15\text{V}$, Unless Otherwise Specified

PARAMETER	TEST CONDITIONS	HI-565AJ, HI565AS			HI-565AK, HI-565AT			UNITS
		MIN	TYP	MAX	MIN	TYP	MAX	
DATA INPUTS (Pins 13 to 24)								
Input Voltage Bit ON Logic "1"	(T _{MIN} to T _{MAX})	+2.0	-	+5.5	+2.0	-	+5.5	V
Input Voltage Bit OFF Logic "0"	(T _{MIN} to T _{MAX})	-	-	+0.8	-	-	+0.8	V
Logic Current Bit ON Logic "1"	(T _{MIN} to T _{MAX})	-	0.01	+1.0	-	0.01	+1.0	μA
Logic Current Bit OFF Logic "0"	(T _{MIN} to T _{MAX})	-	-2.0	-20	-	-2.0	-20	μA
Resolution	(Note 2)	12	-	-	12	-	-	Bits
OUTPUT								
Unipolar Current	(All Bits ON)	-1.6	-2.0	-2.4	-1.6	-2.0	-2.4	mA
Bipolar Current	(All Bits ON or OFF)	±0.8	±1.0	±1.2	±0.8	±1.0	±1.2	mA
Resistance	(Exclusive of Span Resistors) (Note 2)	1.8K	2.5K	3.2K	1.8K	2.5K	3.2K	Ω
Unipolar Offset (25°C)		-0.05	0.01	0.05	-0.05	0.01	0.05	% of FS
		-0.07	0.01	0.07	-0.07	0.01	0.07	% of FS
Bipolar Offset (25°C)		-0.15	0.05	0.15	-0.1	0.05	0.1	% of FS
Bipolar Offset (T _{MIN} to T _{MAX}) /883 Versions Only	(Figure 2, R ₃ = 50Ω)	-0.25	0.05	0.25	-0.2	0.05	0.2	% of FS
Capacitance		-	20	-	-	20	-	pF
Compliance Voltage	(T _{MIN} to T _{MAX})(Note 2)	-1.5	-	+10	-1.5	-	+10	V
ACCURACY (Error Relative to Full Scale)								
Integral Non-Linearity	(25°C) End Point Method	-	±0.25 (0.006)	±0.50 (0.012)	-	±0.12 (0.003)	±0.25 (0.006)	LSB % of FS
Integral Non-Linearity /883 Versions Only	(T _{MIN} to T _{MAX}) End Point Method	-	±0.50 (0.012)	±0.75 (0.018)	-	±0.25 (0.006)	±0.50 (0.012)	LSB % of FS
Differential Non-Linearity	25°C	-	±0.50	±0.75	-	±0.25	±0.50	LSB
Differential Non-Linearity	T _{MIN} to T _{MAX}	MONOTONICITY GUARANTEED						

HI-565A

Electrical Specifications $T_A = 25^\circ\text{C}$, $V_{CC} = +15\text{V}$, $V_{EE} = -15\text{V}$, Unless Otherwise Specified (Continued)

PARAMETER	TEST CONDITIONS	HI-565AJ, HI565AS			HI-565AK, HI-565AT			UNITS
		MIN	TYP	MAX	MIN	TYP	MAX	
TEMPERATURE COEFFICIENTS								
Unipolar Offset Drift		-	1	2	-	1	2	ppm/ $^\circ\text{C}$
Bipolar Zero Drift	Internal Reference	-	5	10	-	5	10	ppm/ $^\circ\text{C}$
Gain Drift, Uni- and Bipolar (Full Scale)	Internal Reference	-	15	40	-	10	25	ppm/ $^\circ\text{C}$
Differential Nonlinearity Error Drift	Int. Ref.	-	2	-	-	2	-	ppm/ $^\circ\text{C}$
SETTLING TIME $T_0 \pm 0.5$ LSB								
With High, Z External Load	(Notes 2, 3)	-	350	500	-	350	500	ns
With 75Ω External Load	(Notes 2, 3)	-	150	250	-	150	250	ns
FULL SCALE TRANSITION From 50% of Logic Input to 90% of Analog Output								
Rise Time	(Note 2)	-	15	30	-	15	30	ns
Fall Time	(Note 2)	-	30	50	-	30	50	ns
POWER REQUIREMENTS								
I_{CC}		-	9.0	11.8	-	9.0	11.8	mA
I_{EE}		-	-9.5	-14.5	-	-9.5	-14.5	mA
POWER SUPPLY GAIN SENSITIVITY (Note 4)								
V_{CC}	(+11.4 to +16.5 V_{DC}) All Bits = 2V, Unipolar	-	3	10	-	3	10	ppm of FS/%
V_{EE}	(-11.4 to -16.5 V_{DC}) All Bits = 2V, Unipolar	-	15	25	-	15	25	ppm of FS/%
PROGRAMMABLE OUTPUT RANGES (See Table 2)								
Unipolar 5	(Note 2)	0 to +5			0 to +5			V
Bipolar 5	(Note 2)	-2.5 to +2.5			-2.5 to +2.5			V
Unipolar 10	(Note 2)	0 to +10			0 to +10			V
Bipolar 10	(Note 2)	-5 to +5			-5 to +5			V
Bipolar 20	(Note 2)	-10 to +10			-10 to +10			V
EXTERNAL ADJUSTMENTS								
Gain Error	$R_2 = 50\Omega$ (Figure 2)	-	± 0.1	± 0.25	-	± 0.1	± 0.25	% of FS
Bipolar Zero Error	$R_3 = 50\Omega$ (Figure 3)	-	± 0.05	± 0.15	-	± 0.05	± 0.1	% of FS
Gain Adjustment Range	(Figure 1) (Note 2)	± 0.25	-	-	± 0.25	-	-	% of FS
Bipolar Zero Adjustment Range	(Note 2)	± 0.15	-	-	± 0.15	-	-	% of FS
REFERENCE INPUT								
Input Impedance	(Note 2)	15K	20K	25K	15K	20K	25K	-
REFERENCE OUTPUT								
Voltage, Commercial Versions		9.90	10.00	10.10	9.90	10.00	10.10	V
Voltage, /883 Versions		9.95	10.00	10.05	9.95	10.00	10.05	V
Current (Available for External Loads)		1.5	2.5	-	1.5	2.5	-	mA

NOTES:

2. Guaranteed by characterization or design but not tested over the operating temperature range.
3. See settling time discussion and Figure 3.
4. The Power Supply Gain Sensitivity is tested in reference to a V_{CC} , V_{EE} of $\pm 15\text{V}$.

Definitions of Specifications

Digital Inputs

The HI-565A accepts digital input codes in binary format and may be user connected for any one of three binary codes. Straight Binary, Two's Complement (Note 5), or Offset Binary, (See Operating Instructions).

TABLE 1.

DIGITAL INPUT	ANALOG OUTPUT		
	STRAIGHT BINARY	OFFSET BINARY	(NOTE 5) TWO'S COMPLEMENT
MSB...LSB			
000...000	Zero	-FS (Full Scale)	Zero
100...000	$1/2$ FS	Zero	-FS
111...111	+FS - 1 LSB	+FS - 1 LSB	Zero - 1 LSB
011...111	$1/2$ FS - 1 LSB	Zero - 1 LSB	+FS - 1 LSB

NOTE:

- Invert MSB with external inverter to obtain Two's Complement Coding.

Nonlinearity of a D/A converter is an important measure of its accuracy. It describes the deviation from an ideal straight line transfer curve drawn between zero (all bits OFF) and full scale (all bits ON) (End Point Method).

Differential Nonlinearity for a D/A converter, it is the difference between the actual output voltage change and the ideal (1 LSB) voltage change for a one bit change in code. A Differential Nonlinearity of ± 1 LSB or less guarantees monotonicity; i.e., the output always increases for an increasing input.

Settling Time is the time required for the output to settle to within the specified error band for any input code transition. It is usually specified for a full scale or major carry transition, settling to within ± 0.5 LSB of final value.

Gain Drift is the change in full scale analog output over the specified temperature range, expressed in parts per million of full scale range per $^{\circ}\text{C}$ (ppm of FSR/ $^{\circ}\text{C}$). Gain error is measured with respect to 25°C at high (T_H) and low (T_L) temperatures. Gain drift is calculated for both high ($T_H - 25^{\circ}\text{C}$) and low ranges ($25^{\circ}\text{C} - T_L$) by dividing the gain error by the respective change in temperature. The specification is the larger of the two representing worst-case drift.

Offset Drift is the change in analog output with all bits OFF over the specified temperature range expressed in parts per million of full scale range per $^{\circ}\text{C}$ (ppm of FSR/ $^{\circ}\text{C}$). Offset error is measured with respect to 25°C at high (T_H) and low (T_L) temperatures. Offset Drift is calculated for both high ($T_H - 25^{\circ}\text{C}$) and low ($25^{\circ}\text{C} - T_L$) ranges by dividing the offset error by the respective change in temperature. The specification given is the larger of the two, representing worst-case drift.

Power Supply Sensitivity is a measure of the change in gain and offset of the D/A converter resulting from a change in -15V or +15V supplies. It is specified under DC conditions and expressed as parts per million of full scale range per percent of change in power supply (ppm of FSR/%).

Compliance Voltage is the maximum output voltage range that can be tolerated and still maintain its specified accuracy. Compliance Limit implies functional operation only, and makes no claims to accuracy.

Glitch a glitch on the output of a D/A converter is a transient spike resulting from unequal internal ON-OFF switching times. Worst case glitches usually occur at half-scale or the major carry code transition from 011...1 to 100...0 or vice versa. For example, if turn ON is greater than turn OFF for 011...1 to 100...0, an intermediate state of 000...0 exists, such that, the output momentarily glitches toward zero output. Matched switching times and fast switching will reduce glitches considerably.

Detailed Description

Op Amp Selection

The HI-565As current output may be converted to voltage using the standard connections shown in Figures 1 and 2. The choice of operational amplifier should be reviewed for each application, since a significant trade-off may be made between speed and accuracy.

For highest precision, use an HA-5130. This amplifier contributes negligible error, but requires about $11\mu\text{s}$ to settle within $\pm 0.1\%$ following a 10V step.

The Harris Semiconductor HA-2600 is the best all-around choice for this application, and it settles in $1.5\mu\text{s}$ (also to $\pm 0.1\%$ following a 10V step). Remember, settling time for the DAC amplifier combination is the square root of t_D^2 plus t_A^2 , where t_D , t_A are settling times for the DAC and amplifier.

No-Trim Operation

The HI-565A will perform as specified without calibration adjustments. To operate without calibration, substitute 50Ω resistors for the 100Ω trimming potentiometers: In Figure 1 replace R2 with 50Ω also remove the network on pin 8 and connect 50Ω to ground. For bipolar operation in Figure 2, replace R3 and R4 with 50Ω resistors.

With these changes, performance is guaranteed as shown under Specifications, "External Adjustments". Typical unipolar zero will be ± 0.5 LSB plus the op amp offset.

The feedback capacitor, C, must be selected to minimize settling time.

Calibration

Calibration provides the maximum accuracy from a converter by adjusting its gain and offset errors to zero. For the HI-565A, these adjustments are similar whether the current output is used, or whether an external op amp is

HI-565A

added to convert this current to a voltage. Refer to Table 2 for the voltage output case, along with Figure 1 or Figure 2.

Calibration is a two step process for each of the five output ranges shown in Table 2. First adjust the negative full scale (zero for unipolar ranges). This is an offset adjust which translates the output characteristic, i.e., affects each code by the same amount.

Next adjust positive FS. This is a gain error adjustment, which rotates the output characteristic about the negative FS value.

For the bipolar ranges, this approach leaves an error at the zero code, whose maximum value is the same as for integral nonlinearity error. In general, only two values of output may be calibrated exactly; all others must tolerate some error. Choosing the extreme end points (plus and minus full scale) minimizes this distributed error for all other codes.

TABLE 2. OPERATING MODES AND CALIBRATION

MODE	CIRCUIT CONNECTIONS				CALIBRATION		
	OUTPUT PRANGE	PIN 10 TO	PIN 11 TO	RESISTOR (R)	APPLY INPUT CODE	ADJUST	TO SET V_O
Unipolar (See Figure 1)	0 to +10V	V_O	Pin 10	1.43K	All 0's All 1's	R1 R2	0V +9.99756V
	0 to +5V	V_O	Pin 9	1.1K	All 0's All 1's	R1 R2	0V +4.99878V
Bipolar (See Figure 2)	$\pm 10V$	NC	V_O	1.69K	All 0's All 1's	R3 R4	-10V +9.99512V
	$\pm 5V$	V_O	Pin 10	1.43K	All 0's All 1's	R3 R4	-5V +4.99756V
	$\pm 2.5V$	V_O	Pin 9	1.1K	All 0's All 1's	R3 R4	-2.5V +2.49878V

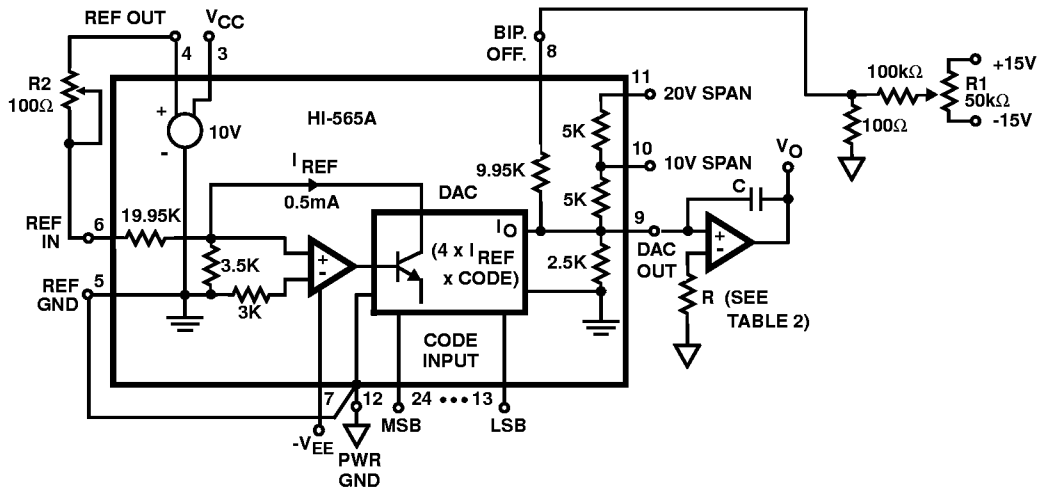

FIGURE 1. UNIPOLAR VOLTAGE OUTPUT

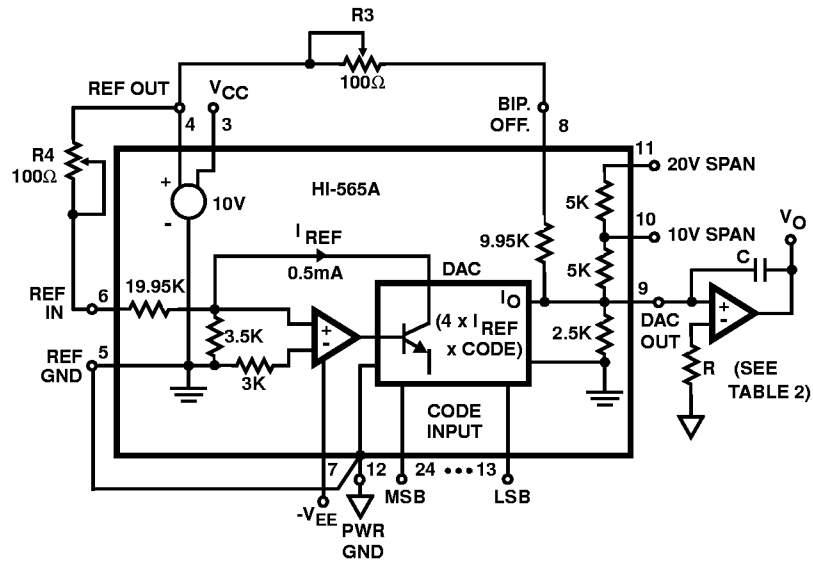

FIGURE 2. BIPOLAR VOLTAGE OUTPUT

Settling Time

This is a challenging measurement, in which the result depends on the method chosen, the precision and quality of test equipment and the operating configuration of the DAC (test conditions). As a result, the different techniques in use by converter manufacturers can lead to consistently different results. An engineer should understand the advantage and limitations of a given test method before using the specified settling time as a basis for design.

The previous approach calls for a strobed comparator to sense final perturbations of the DAC output waveform. This gives the LSB a reasonable magnitude (814μV for the HI-565A), which provides the comparator with enough overdrive to establish an accurate ±0.5 LSB window about the final settled value. Also, the required test conditions simulate the DACs environment for a common application - use in a successive approximation A/D converter. Considerable experience has shown this to be a reliable and repeatable way to measure settling time.

The usual specification is based on a 10V step, produced by simultaneously switching all bits from off-to-on (tON) or on-to-off (tOFF). The slower of the two cases is specified, as measured from 50% of the digital input transition to the final entry within a window of ±0.5 LSB about the settled value. Four measurements characterize a given type of DAC:

- (a) tON, to final value +0.5 LSB
- (b) tON, to final value -0.5 LSB
- (c) tOFF, to final value +0.5 LSB
- (d) tOFF, to final value -0.5 LSB

(Cases (b) and (c) may be eliminated unless the overshoot exceeds 0.5 LSB). For example, refer to Figure 3 for the measurement of case (d).

Procedure

As shown in Figure 3B, settling time equals tx plus the comparator delay (tD = 15ns). To measure tx:

- Adjust the delay on generator No. 2 for a tx of several microseconds. This assures that the DAC output has settled to its final value.
- Switch on the LSB (+5V).
- Adjust the VLSB supply for 50% triggering at COMPARATOR OUT. This is indicated by traces of equal brightness on the oscilloscope display as shown in Figure 3B. Note DVM reading.
- Switch the LSB to Pulse (P).
- Readjust the VLSB supply for 50% triggering as before, and note DVM reading. One LSB equals one tenth the difference in the DVM readings noted above.
- Adjust the VLSB supply to reduce the DVM reading by 5 LSBs (DVM reads 10X, so this sets the comparator to sense the final settled value minus 0.5 LSB). Comparator output disappears.
- Reduce generator No. 2 delay until comparator output reappears, and adjust for "equal brightness".
- Measure tx from scope as shown in Figure 3B. Settling time equals tx + tD, i.e., tx + 15ns.

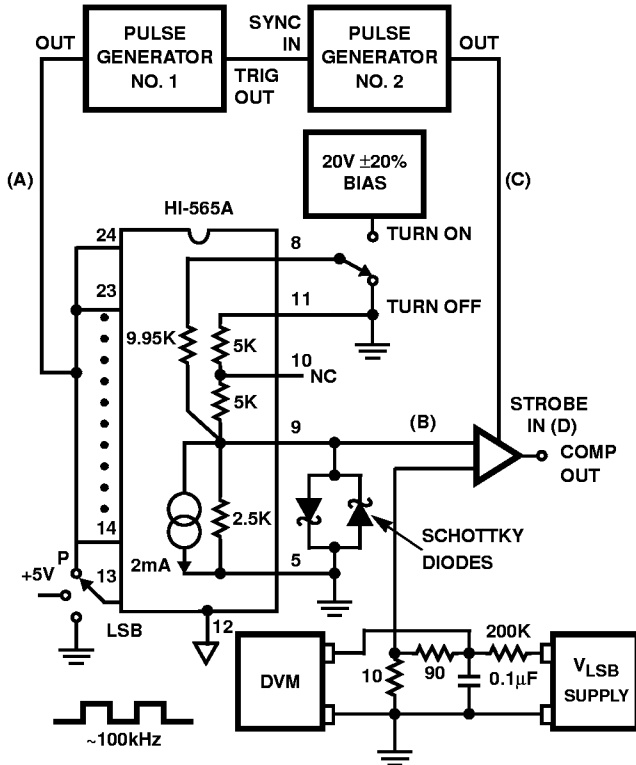

FIGURE 3A.

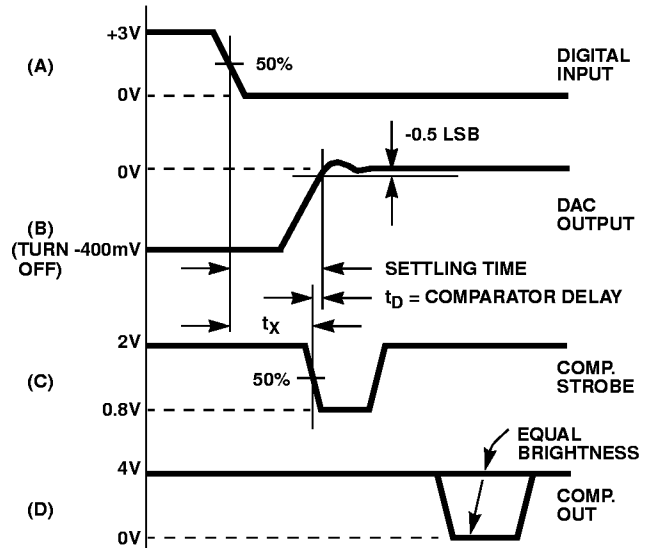

FIGURE 3B.

Other Considerations

Grounds

The HI-565A has two ground terminals, pin 5 (REF GND) and pin 12 (PWR GND). These should not be tied together near the package unless that point is also the system signal ground to which all returns are connected. (If such a point exists, then separate paths are required to pins 5 and 12).

The current through pin 5 is near-zero DC (Note 1); but pin 12 carries up to 1.75mA of code-dependent current from bits 1, 2, and 3. The general rule is to connect pin 5 directly to the system "quiet" point, usually called signal or analog ground. Connect pin 12 to the local digital or power ground. Then, of course, a single path must connect the analog/signal and digital/power grounds.

Layout

Connections to pin 9 (I_{OUT}) on the HI-565A are most critical for high speed performance. Output capacitance of the DAC is only 20pF, so a small change or additional capacitance may alter the op amp's stability and affect settling time. Connections to pin 9 should be short and few. Component leads should be short on the side connecting to pin 9 (as for feedback capacitor C). See the Settling Time section.

Bypass Capacitors

Power supply bypass capacitors on the op amp will serve the HI-565A also. If no op amp is used, a 0.01µF ceramic capacitor from each supply terminal to pin 12 is sufficient, since supply current variations are small.

Current Cancellation

Current cancellation is a two step process within the HI-565A in which code dependent variations are eliminated, then the resulting DC current is supplied internally. First an auxiliary 9-bit R-2R ladder is driven by the complement of the DACs input code. Together, the main and auxiliary ladders draw a continuous 2.25mA from the internal ground node, regardless of input code. Part of this DC current is supplied by the zener voltage reference, and the remainder is sourced from the positive supply via a current mirror which is laser trimmed for zero current through the external terminal (pin 5).

HI-565A

Die Characteristics

DIE DIMENSIONS:

179 mils x 107 mils x 19 mils ± 1 mil

METALLIZATION:

Type: Al
Thickness: $16\text{k}\text{\AA} \pm 2\text{k}\text{\AA}$

PASSIVATION:

Type: Nitride Over Silox
Nitride Thickness: $3.5\text{k}\text{\AA} \pm 0.5\text{k}\text{\AA}$
Silox Thickness: $12\text{k}\text{\AA} \pm 1.5\text{k}\text{\AA}$

WORST CASE CURRENT DENSITY:

$0.75 \times 10^5 \text{ A/cm}^2$

TRANSISTOR COUNT:

200

Metallization Mask Layout

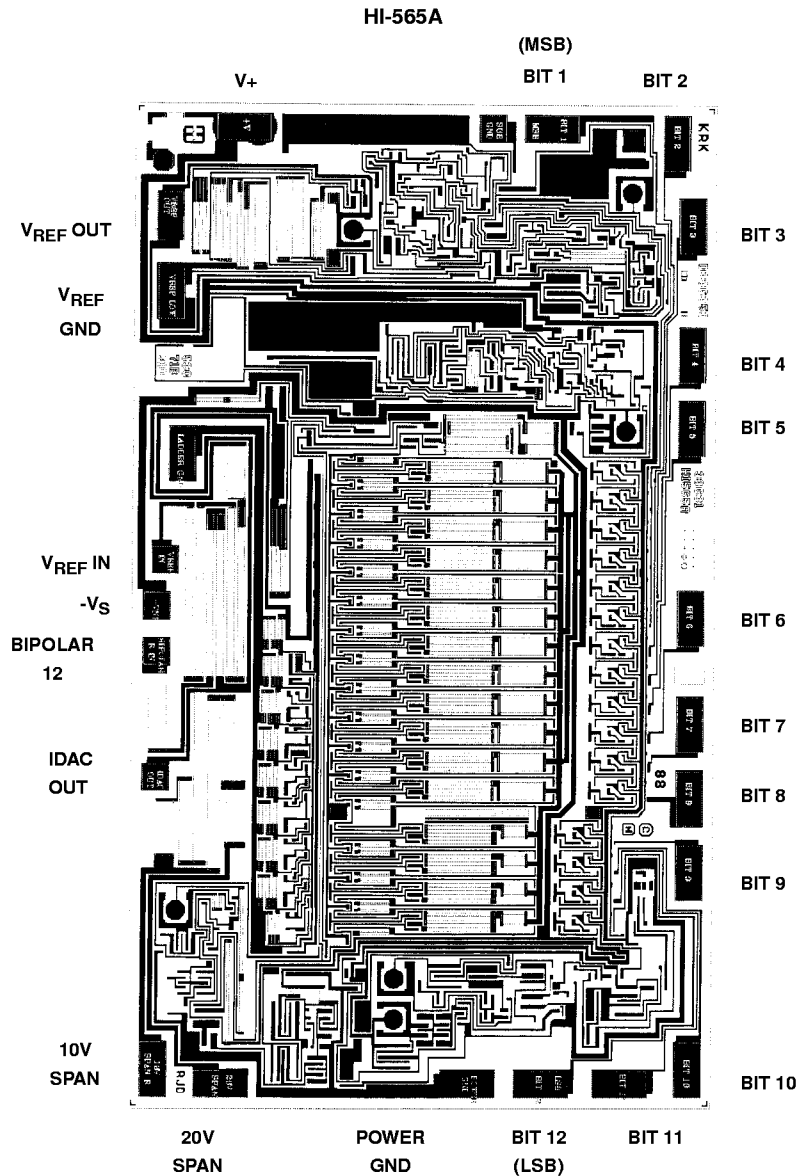

Ceramic Dual-In-Line Metal Seal Packages (SBDIP)

**D24.6 MIL-STD-1835 CDIP2-T24 (D-3, CONFIGURATION C)
24 LEAD CERAMIC DUAL-IN-LINE METAL SEAL PACKAGE**

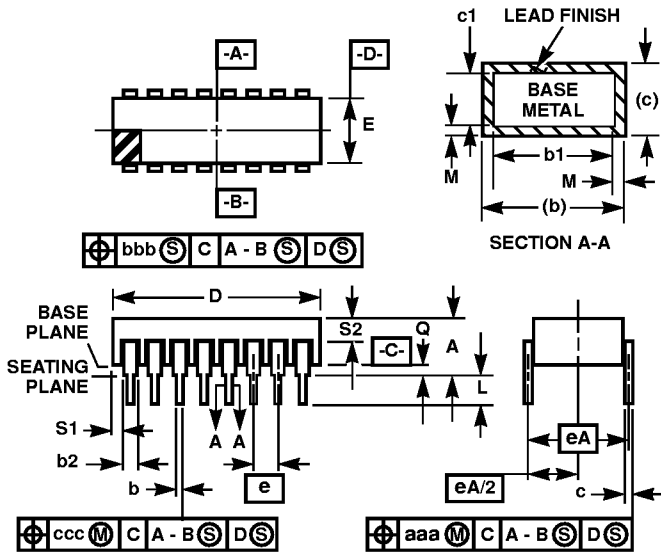

SYMBOL	INCHES		MILLIMETERS		NOTES
	MIN	MAX	MIN	MAX	
A	-	0.225	-	5.72	-
b	0.014	0.026	0.36	0.66	2
b1	0.014	0.023	0.36	0.58	3
b2	0.045	0.065	1.14	1.65	-
b3	0.023	0.045	0.58	1.14	4
c	0.008	0.018	0.20	0.46	2
c1	0.008	0.015	0.20	0.38	3
D	-	1.290	-	32.77	-
E	0.500	0.610	12.70	15.49	-
e	0.100 BSC		2.54 BSC		-
eA	0.600 BSC		15.24 BSC		-
eA/2	0.300 BSC		7.62 BSC		-
L	0.120	0.200	3.05	5.08	-
Q	0.015	0.075	0.38	1.91	5
S1	0.005	-	0.13	-	6
S2	0.005	-	0.13	-	7
α	90°	105°	90°	105°	-
aaa	-	0.015	-	0.38	-
bbb	-	0.030	-	0.76	-
ccc	-	0.010	-	0.25	-
M	-	0.0015	-	0.038	2
N	24		24		8

NOTES:

1. Index area: A notch or a pin one identification mark shall be located adjacent to pin one and shall be located within the shaded area shown. The manufacturer's identification shall not be used as a pin one identification mark.
2. The maximum limits of lead dimensions b and c or M shall be measured at the centroid of the finished lead surfaces, when solder dip or tin plate lead finish is applied.
3. Dimensions b1 and c1 apply to lead base metal only. Dimension M applies to lead plating and finish thickness.
4. Corner leads (1, N, N/2, and N/2+1) may be configured with a partial lead paddle. For this configuration dimension b3 replaces dimension b2.
5. Dimension Q shall be measured from the seating plane to the base plane.
6. Measure dimension S1 at all four corners.
7. Measure dimension S2 from the top of the ceramic body to the nearest metallization or lead.
8. N is the maximum number of terminal positions.
9. Braze fillets shall be concave.
10. Dimensioning and tolerancing per ANSI Y14.5M - 1982.
11. Controlling dimension: INCH.

Rev. 0 4/94

All Harris semiconductor products are manufactured, assembled and tested under **ISO9000** quality systems certification.

Harris semiconductor products are sold by description only. Harris Corporation, Semiconductor Communications Division, reserves the right to make changes in circuit design and/or specifications at any time without notice. Accordingly, the reader is cautioned to verify that data sheets are current before placing orders. Information furnished by Harris is believed to be accurate and reliable. However, no responsibility is assumed by Harris or its subsidiaries for its use; nor for any infringements of patents or other rights of third parties which may result from its use. No license is granted by implication or otherwise under any patent or patent rights of Harris or its subsidiaries.

For information regarding Harris Corporation's Semiconductor Communications Division and its products, call **1-800-4-HARRIS** or see web site <http://www.semi.harris.com>

Sales Office Headquarters

NORTH AMERICA

Harris Corporation,
Semiconductor Communications Division
P. O. Box 883, Mail Stop 53-210
Melbourne, FL 32902
TEL: 1-800-442-7747
(407) 727-9207
FAX: (407) 724-3973

EUROPE

Harris Corporation,
Semiconductor Communications Division
Mercure Center
100, Rue de la Fusee
1130 Brussels, Belgium
TEL: (32) 2.724.2111
FAX: (32) 2.724.22.05

ASIA

Harris Corporation,
Semiconductor Communications Division,
Taiwan Limited
7F-6, No. 101 Fu Hsing North Road
Taipei, Taiwan
Republic of China
TEL: (886) 2 2716 9310
FAX: (886) 2 2715 3029