

MAXIM

MAX3766 Evaluation Kit

General Description

The MAX3766 evaluation kit (EV kit) is an assembled, surface-mount demonstration board that provides easy optical or electrical evaluation of the MAX3766 622Mbps laser driver.

Ordering Information

PART	TEMP. RANGE	PIN-PACKAGE
MAX3766EVKIT	-40°C to +85°C	MAX3766EEP

Features

- ◆ Adjustable Modulation Temperature Coefficient
- ◆ Automatic Safety Reset Delay with MAX809M
- ◆ Automatic Power Control Evaluation in Electrical and Optical Configuration
- ◆ Dual Layout Option on Single Board
- ◆ Fully Assembled and Tested

Component List

DESIGNATION	QTY	DESCRIPTION
B1	1	Ferrite bead Murata BLM11A601S
C1	1	10 μ F \pm 10%, 16V min tantalum cap AVX TAJC106K016
C2, C12, C14	3	0.01 μ F 10%, 25V min ceramic capacitors
C4, C7, C10, C11, C15, C18	6	0.1 μ F 10%, 25V min ceramic capacitors
C8, C9	2	DO NOT INSTALL
C16	1	15pF 10%, 25V min ceramic capacitor
C17	1	1 μ F 10%, 10V min ceramic AVX0805ZC105k
D1 SOCKETS	4	Pin sockets Digi-Key ED5042-ND
JU5	1	2-pin header (0.1" center) Digi-Key S1012-36-ND
IN+, IN-, IOUT-	3	SMA connectors (edge mount) E.F. Johnson 142-0701-801 or Digi-Key J502-ND
JU1, JU3, JU4	3	3-pin headers (0.1" centers) Digi-Key S1012-36-ND
JU1, JU3, JU4, JU5	4	Shunts Digi-Key S9000-ND

DESIGNATION	QTY	DESCRIPTION
L1	1	DO NOT INSTALL
Q1	1	PNP transistor Zetex FMMT591, SOT23
R1	1	0 Ω jumper
R2, R6, R9	3	50k Ω variable resistors Bourns 3296
R3, R12	2	221 Ω , 1% resistors
R4	1	20 Ω , 5% resistor
R5, R7	2	100k Ω variable resistors Bourns 3296
R8, R20	2	5.1k Ω , 5% resistors
R10, R11	2	68.1 Ω , 1% resistors
R13	1	10 Ω , 5% resistor
R14	1	24.9 Ω , 1% resistor
R15, R16	2	182 Ω , 1% resistors
R17	1	33.2 Ω , 1% resistor
R18	1	100k Ω , 5% resistor
R21	1	49.9 Ω , 1% resistor
U1	1	MAX3766EEP, QSOP-20
U2	1	MAX495ESA, SOIC-8
U3	1	MAX809MEUR-T
+5V, GND	2	Test points Mouser 151-203
None	1	MAX3766 circuit board (rev. C)
None	1	MAX3766 data sheet

Evaluates: MAX3766

MAX3766 Evaluation Kit

Component Suppliers

SUPPLIER	PHONE	FAX
AVX	(806) 946-0690	(803) 626-3123
Murata	(770) 436-1300	(770) 436-3030
Zetex	(516) 543-7100	(516) 864-7630

Electrical Quick Start

- 1) Ensure that solder bridges JU7 and JU6 are shorted, and that solder bridge JU2 is open.
- 2) Install a shunt on JU5.
- 3) Install a shunt on JU3 between pins 2 and 3.
- 4) Install a shunt on JU1 between pins 2 and 3 (all fail conditions ignored).
- 5) Remove the shunt from JU4.
- 6) Turn the RTC potentiometer counterclockwise to 0k Ω (minimum tempco). Also turn the RBIASMAX potentiometer clockwise to 0k Ω .
- 7) Connect a 50 Ω terminated oscilloscope from a 50 Ω cable to IOUT-. Set the oscilloscope vertical gain to 100mV/div.
- 8) Apply a 500mV minimum differential input signal at IN- (J1) and IN+ (J2).
- 9) Power up the board with a 5V supply at the +5V and GND test pins. Set the current limit to 300mA.
- 10) Adjust RMODSET until a signal appears on the oscilloscope. The conversion gain from the MAX3766 modulation current to the oscilloscope output is 0.08mA/mV; therefore 750mV equals a modulation current of 60mA.

Optical Quick Start

- 1) Ensure that solder bridges JU7 and JU2 are open.
- 2) Ensure that solder bridge JU6 is shorted.
- 3) Install a shunt on JU3 and JU4, between pins 2 and 3.
- 4) Install a shunt on JU1 between pins 2 and 3 (all fail conditions ignored).
- 5) Turn the RTC potentiometer counterclockwise to 0k Ω (minimum tempco).
- 6) Adjust the RBIASMAX potentiometer to a safe maximum biasing level for the laser diode used in this evaluation. Measure RBIASMAX from VREF1 to BIASMAX without power applied to the board. (From the MAX3766 data sheet it can be estimated that 1k Ω sets up about 40mA of maximum laser bias current.)

- 7) Turn RMODSET counterclockwise to 50k Ω (minimum modulation current).
- 8) Turn RPOWERSET counterclockwise to 100k Ω (minimum monitor diode (MD) current).
- 9) Insert a TO-46 packaged laser into D1.
- 10) Power up the board with a 5V supply at the +5V and GND test points. Set the current limit to 300mA.
- 11) Connect a 50 Ω cable from IOUT- to a 50 Ω terminated oscilloscope input.
- 12) Apply a 500mV minimum differential input signal at IN- (J1) and IN+ (J2).
- 13) Adjust RPOWERSET and RMODSET clockwise until the desired average optical power and amplitude are displayed on the oscilloscope attached to the optical-to-electrical converter. (*Use caution:* the modulation current could exceed the laser's damage rating.)

Compact Layout

A second, more compact layout is provided on this EV kit PC board. It is designed for optical evaluation only. The schematic is included (Figure 2), but no components are supplied. High-speed performance can be improved with the compact layout.

Laser Safety and IEC 825

Using the MAX3766 laser driver alone does not ensure that a transmitter design is compliant with IEC 825 eye safety requirements. The entire transmitter circuit and component selections must be considered. Each customer must determine the level of fault tolerance required by their application, recognizing that Maxim products are not designed or authorized for use as components in systems intended for surgical implant into the body, for applications intended to support or sustain life, or for any other application where the failure of a Maxim product could create a situation where personal injury or death may occur.

MAX3766 Evaluation Kit

Evaluates: MAX3766

Table 1. Adjustment and Control Descriptions (review Quick Start first)

CONTROL	NAME	FUNCTION
D1	Laser Diode	This is a socket for a laser in a TO-46 header (customer supplied).
JU1	SAFETY	When the JU1 shunt is placed on pins 1 and 2, the MAX3766's safety features are enabled. The MAX809M ensures that failures at start-up are ignored until the voltage level set by the MAX809M is detected on V _{CC} . This allows the MAX3766 to power up without generating a safety shutdown. Shunting pins 2 and 3 disables safety shutdown.
JU2	—	This solder bridge should be shorted only for electrical evaluation when using automatic power control.
JU3	VCC/VCCA	Selects which EV kit layout to supply with power. Shunt pins 1 and 2 to power up U1 (larger layout). Shunt pins 2 and 3 to power up U4 (compact layout).
JU4	MD	Allows board to switch between optical monitor diode current (shunt pins 2 and 3) and electrically-emulated monitor diode current (shunt pins 1 and 2).
JU5	ENABLE	Enables and disables the MAX3766. When shunted, the part is enabled.
JU6	—	This solder bridge should be shorted.
JU7	—	This solder bridge should be open for optical evaluation and shorted for electrical evaluation.
R2	COUPLING	When using the electrically emulated monitor diode current, R2 sets the ratio of laser current to monitor diode current.
R5	RTC	RTC sets the modulation current temperature compensation, 0k Ω = minimum tempco (0ppm/ $^{\circ}$ C) to 100k Ω = maximum tempco (~5600ppm/ $^{\circ}$ C).
R6	RBIASMAX	When in open-loop mode (automatic power control not used), this resistance sets the laser bias current (0k Ω = maximum bias). When in closed-loop mode, it sets the maximum bias current available with automatic power control.
R7	RPOWERSET	Sets the monitor diode reference current in a closed-loop condition (automatic power control engaged). See MAX3766 data sheet for selection of RPOWERSET.
R9	RMODSET	Sets modulation current. 0k Ω = maximum modulation current.

MAX3766 Evaluation Kit

Evaluates: MAX3766

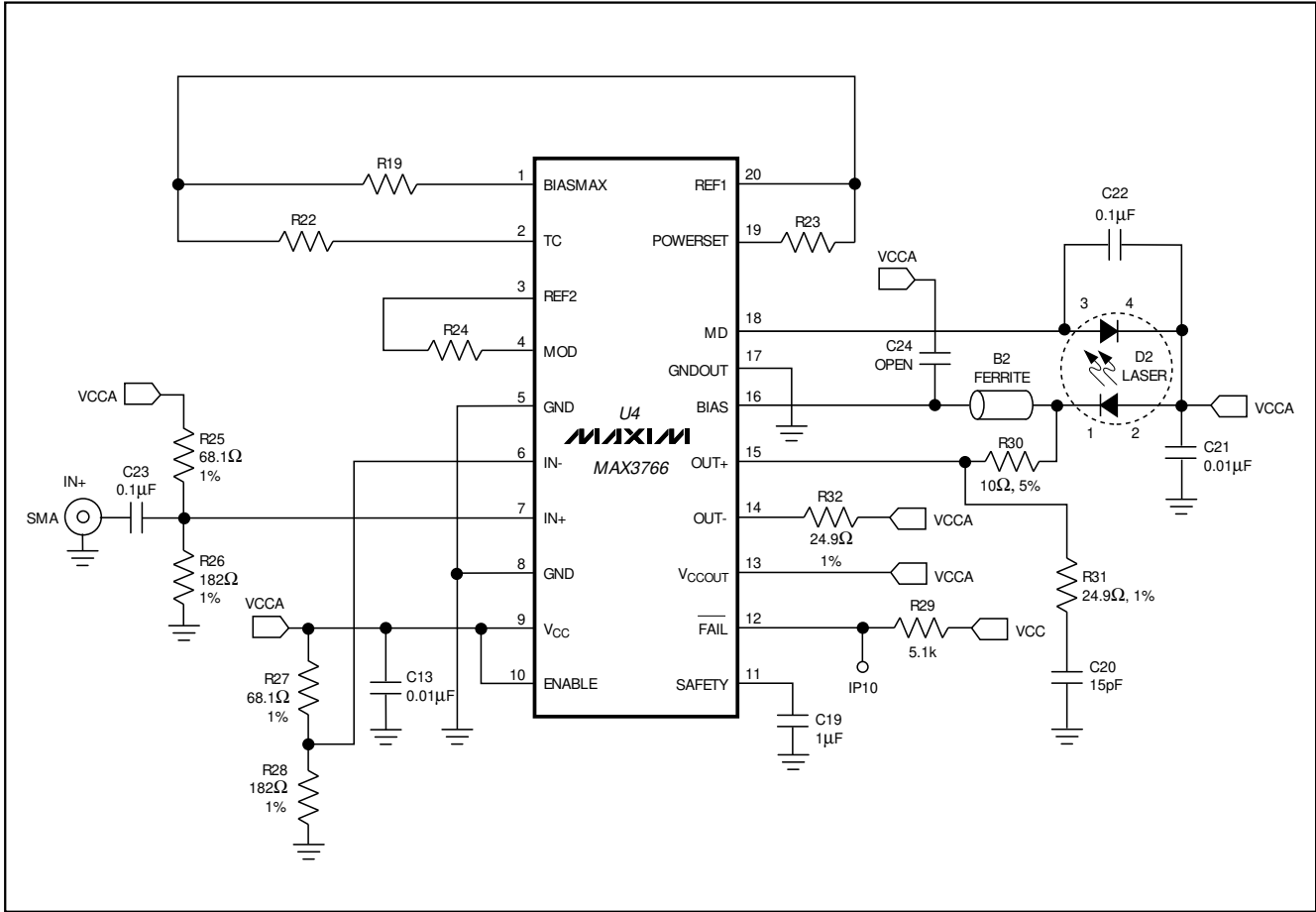

Figure 2. MAX3766 EV Kit Compact Layout (components not supplied, values are for reference only)

Compact Layout Component List (Not Installed and Not Supplied)

DESIGNATION	QTY	DESCRIPTION
B2	1	Ferrite bead Murata BLM11A601S
C13, C21	2	0.01µF capacitors
C19	1	1µF capacitor
C20	1	15pF capacitor
C22, C23	2	0.1µF capacitors
C24	0	DO NOT INSTALL
D2 SOCKET	4	Pin sockets Digi Key ED5042-ND
IN+	1	SMA connector (edge mount) E.F. Johnson 142-0701-801 or Digi Key J502-ND

DESIGNATION	QTY	DESCRIPTION
R19, R22, R23, R24	4	Resistors see (MAX3766 data sheet)
R25, R27	2	68.1Ω, 1% resistors
R26, R28	2	182Ω, 1% resistors
R29	1	5.1k, 5% resistor
R30	1	10Ω, 5% resistor
R31, R32	2	24.9, 1% resistors
U4	1	MAX3766EEP QSOP-20

MAX3766 Evaluation Kit

Evaluates: MAX3766

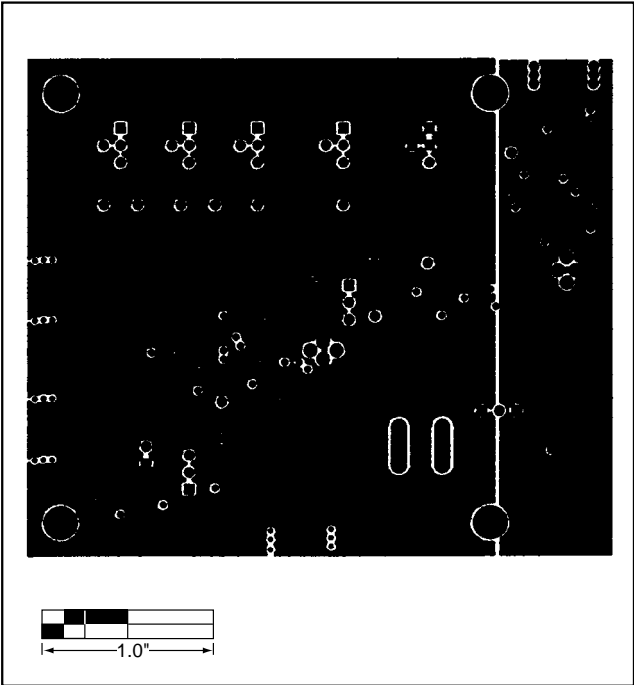

Figure 6. MAX3766 EV Kit PC Board Layout—Power Layer

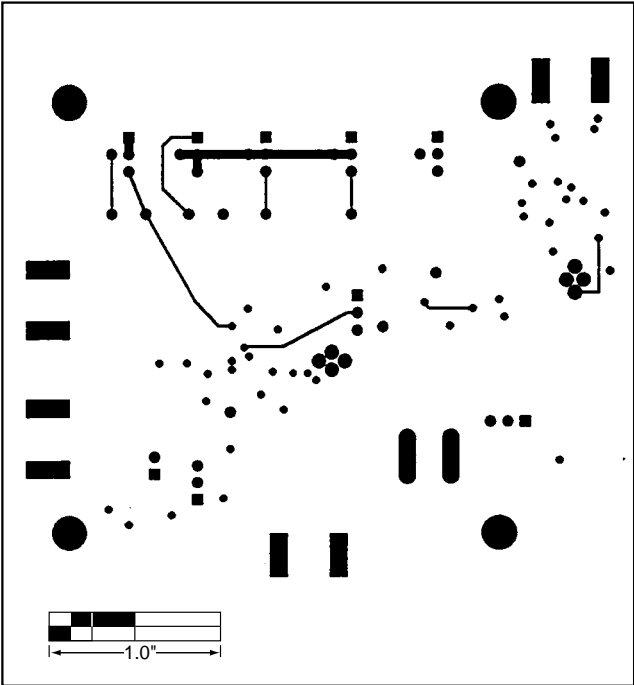

Figure 7. MAX3766 EV Kit PC Board Layout—Solder Side

MAX3766 Evaluation Kit

Evaluates: MAX3766

NOTES

Maxim makes no warranty, representation or guarantee regarding the suitability of its products for any particular purpose, nor does Maxim assume any liability arising out of the application or use of any product or circuit and specifically disclaims any and all liability, including without limitation consequential or incidental damages. "Typical" parameters can and do vary in different applications. All operating parameters, including "typicals" must be validated for each customer application by customer's technical experts. Maxim products are not designed, intended or authorized for use as components in systems intended for surgical implant into the body, or other applications intended to support or sustain life, or for any other application in which the failure of the Maxim product could create a situation where personal injury or death may occur.

8 _____ **Maxim Integrated Products, 120 San Gabriel Drive, Sunnyvale, CA 94086 408-737-7600**