

Power Supply Connectors For Industrial Equipment

PX Series

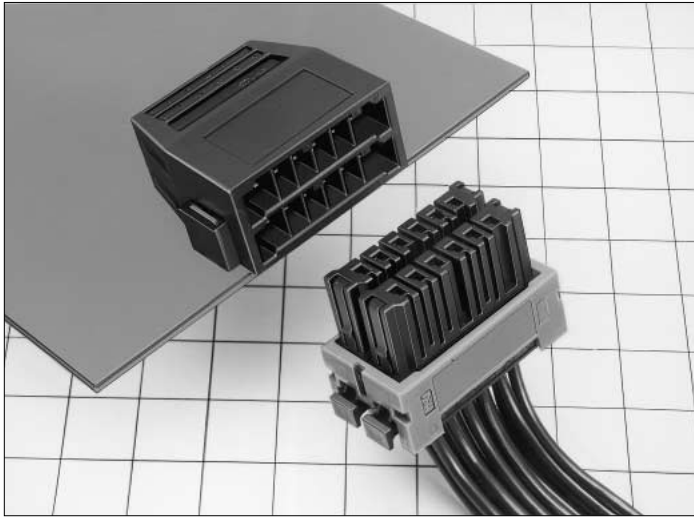

■ Features

1. Power supply connector for high-current:

Withstands voltage of 2200V AC max. and 10A/contact (60A/6contacts) of rated current.

2. Housing design prevents incorrect insertion:

Opening section is designed to prevent reverse insertion and mating direction is easily checked. Additionally, the opening section is keyed to prevent misalignment of plugs in parallel applications. (See the right Pict.①.)

3. Reduced Size:

When compared to traditional products, Hirose's plug is smaller in size by 65% and the receptacle is smaller by 55%. (For more details, refer to page 2.)

4. Reliable contact structure:

- ① Three point contact
- ② Gold plated contacts (standard) with high-level environmental resistance
- ③ Contact spring guard structure
- ④ Structure prevents retainer deformation (Refer to the right Fig.①.)

5. Easy Cable Assembly:

- ① Use of dedicated crimping tools will make harness work easier. One tool crimps both AWG#16 and AWG#18 wire.
- ② Positive lock can be felt on contact insertion.
- ③ Release of contact lock can easily be performed with dedicated jig, which facilitates the wiring modification after assembly.

Structure prevents mis-insertion

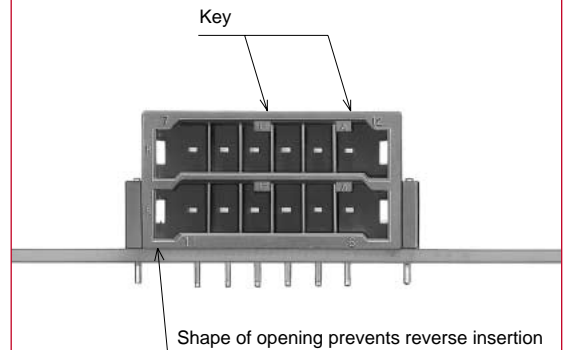

Pict.-①

Reliable terminal structure

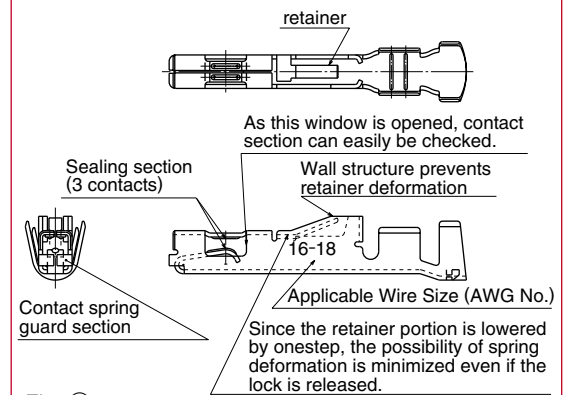
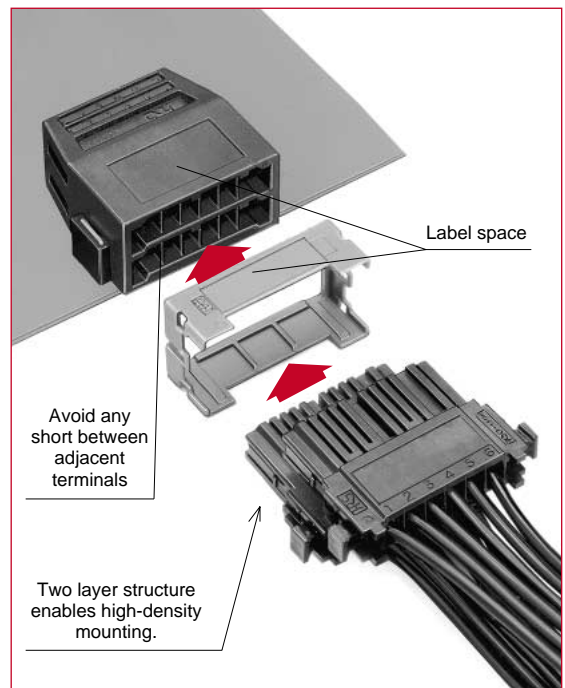

Fig.-①



■Product Specifications

Ratings	Temp. Range	-55°C~+105°C
	Voltage	AC600V
	Current	10A

Description	Specifications	Requirements
1.contact resistance	10mΩ maximum	Measured at 100mA.
2.insulation resistance	1000MΩ minimum	Measured at DC 500V.
3.voltage resistance	No flashover/dielectric breakdown	AC 2200V for 1 minute.
4.Insertion/Withdrawal life	①Contact resistance : 20mΩ or less ②No damage, cracks or looseness of parts	1000 times of insertion/withdrawal
5.vibration resistance	①No instantaneous electric disconnection of 10 μs or more	Frequency:10-55Hz(1cycle,5 min.) One-sided amplitude:Test at 0.75mm, 3 directions for 2 hours, respectively
6.shock resistance	②Contact resistance : 20mΩ or less ③No damage, cracks or looseness of parts	Acceleration: 490m/S ² Duration: 11ms Test at sine half-wave, 3 axes, bi-directional three times, respectively.
7.temperature cycle	①Contact resistance : 20mΩ or less ②Insulation resistance : 1000MΩ or more ③No damage, cracks or looseness of parts	Test the followings for 5 cycles : Temperature : -55→+ 5~+35→+85→+ 5~+35°C Time : 30→ 10~ 15→ 30→ 10~15Minutes
8.humidity resistance in steady state	①Contact resistance : 20mΩ or less ②Insulation resistance : 1000MΩ or more ③No damage, cracks or looseness of parts	Continuous condition of 40±2°C in temperature and 90~95% in humidity for 96 hours.
9.Corrosion, salt mist	①No heavy corrosion	Leave in 5% of salt water for 48 hours.

■Material Quality/Processing

Parts	Material	Finish
Contacts	Copper alloy	Gold plating
Insulator	PBT resin(UL94V-0)	
Metal fixture	Copper alloy	Solder plating

◆Comparison In Size With Conventional Equivalent

		(mm)	
		PX	A company-made
Plug	Width	34.2	44.94
	Height	07.0	07.15
	Depth	23.0	22.80
Receptacle	Width	28.0	39.40
	Height	14.8	18.47
	Depth	27.4	27.18

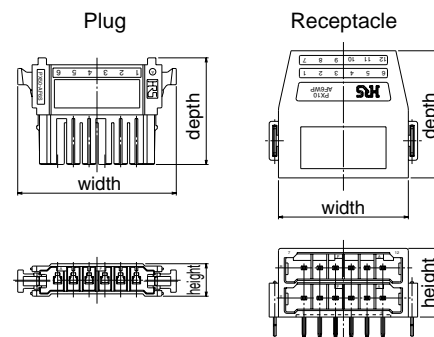

For volume ratio, plug is downsized to : nearly 65%; and receptacle : nearly 55%.

■ Receptacles

● 6position/2row Type



PX10-AF6WP
CL236-0001-0

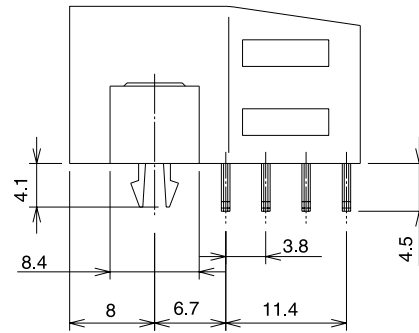
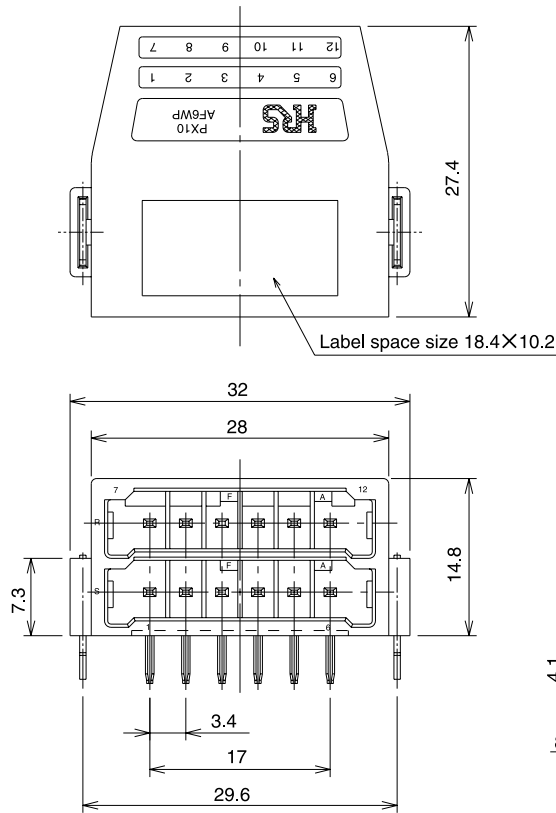

◆ Dimensions For Circuit Board Installation (For Your Information) $t=1.6\sim 2.4$

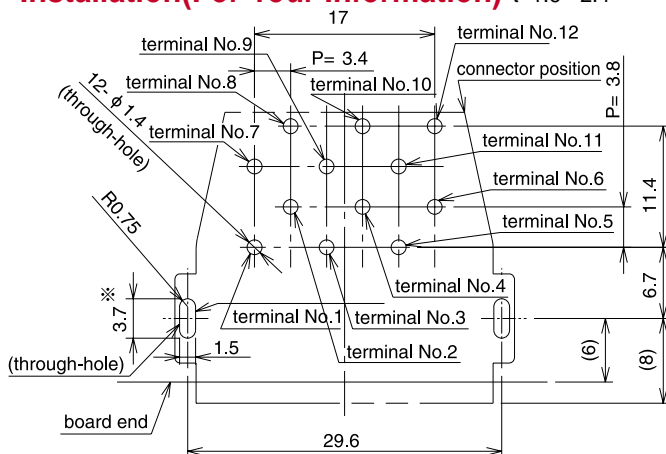

◆ Terminal-To-Terminal Distance Of Board Installed Section

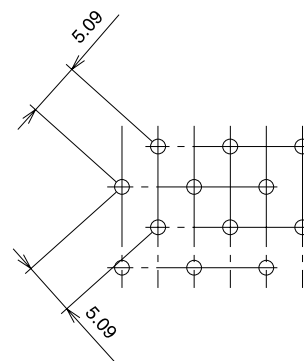

* Where $t=1.6$ (Setting value depends on thickness of boards.)

●4Position/2 Row Type



PX10-AD4WP
CL236-0005-0

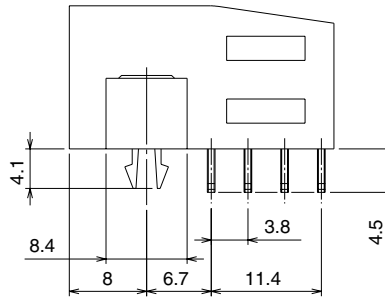
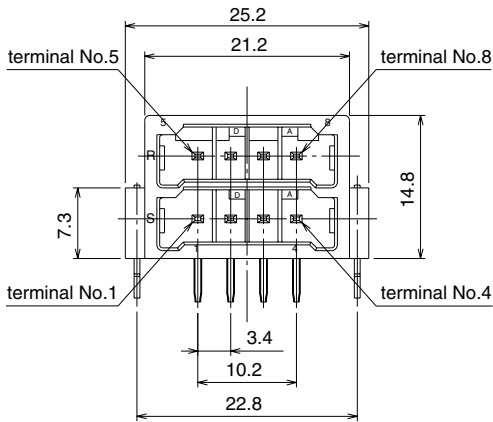
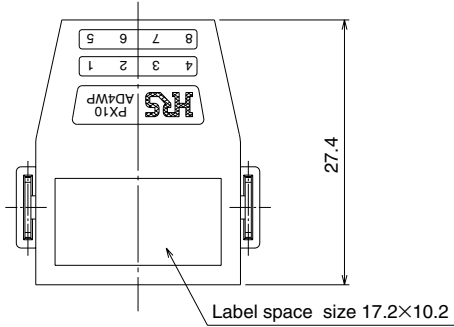

◆ Dimensions For Circuit Board Installation (For Your Information) $t=1.6\sim 2.4$

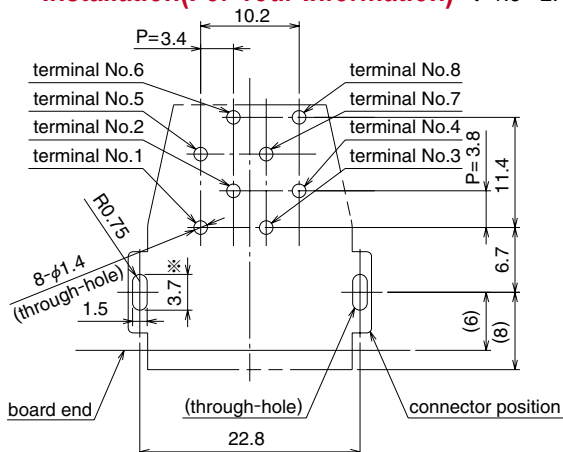

◆ Terminal-To-Terminal Distance Of Board Installed Section

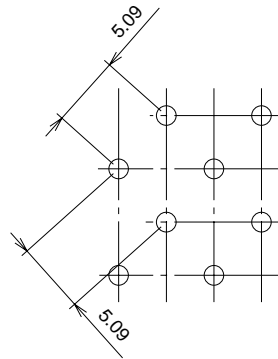

* Where $t=1.6$ (Setting value depends on thickness of boards.)

■ Plug

● 6-Position Type



PX50-AF6S
CL236-0002-2

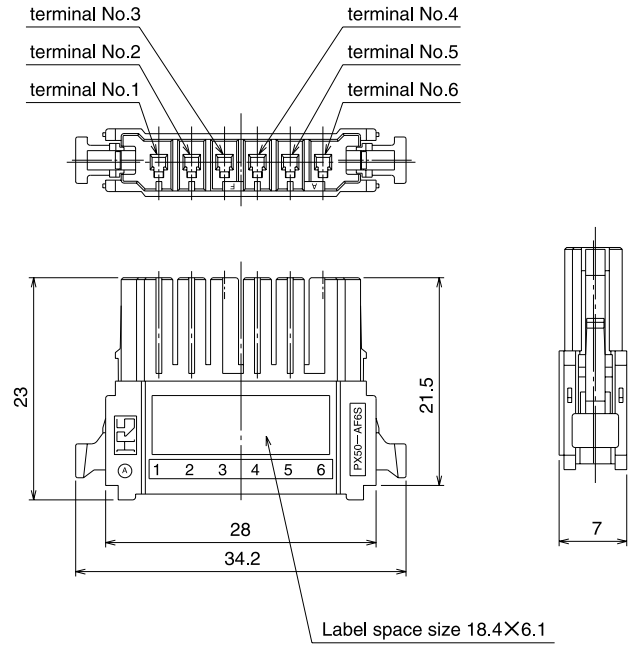

● 4-Position Type

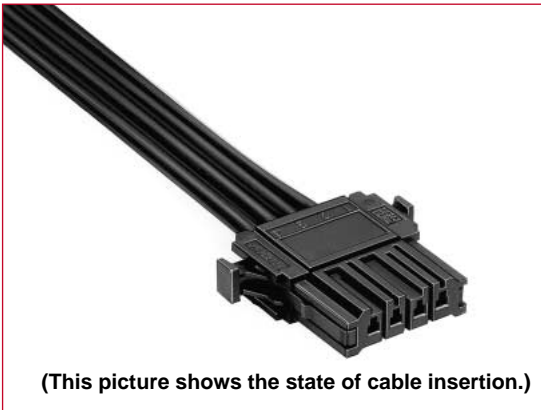

PX50-AD4S
CL236-0006-3

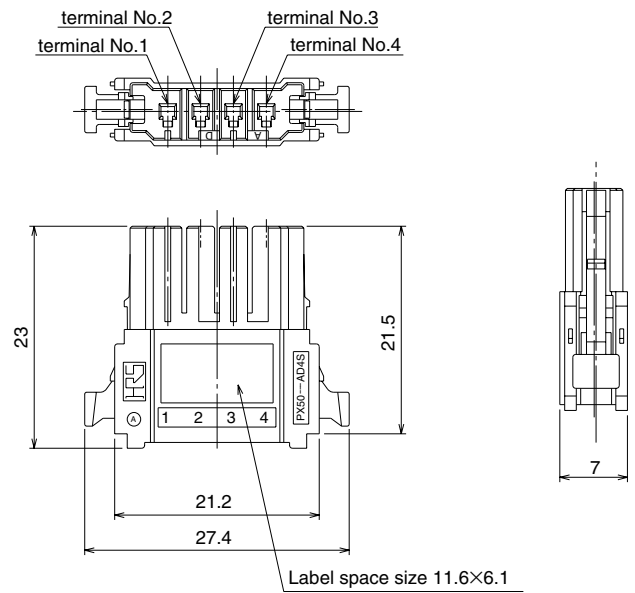

■ Simple-Type Plug Holder Cover

● For 6-Position Type



PX-6WS-CV CL236-0004-8

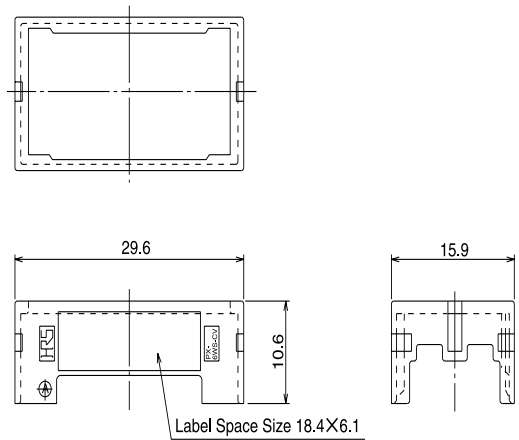

● For 4-Position Type

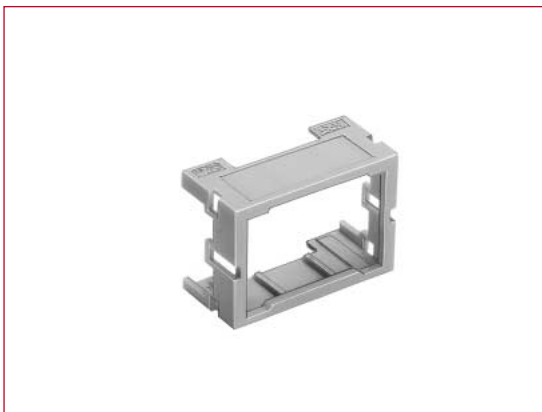

PX-4WS-CV CL236-0007-6

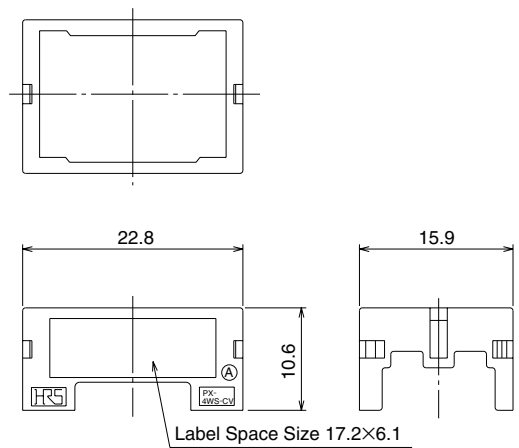

◆ Installation status

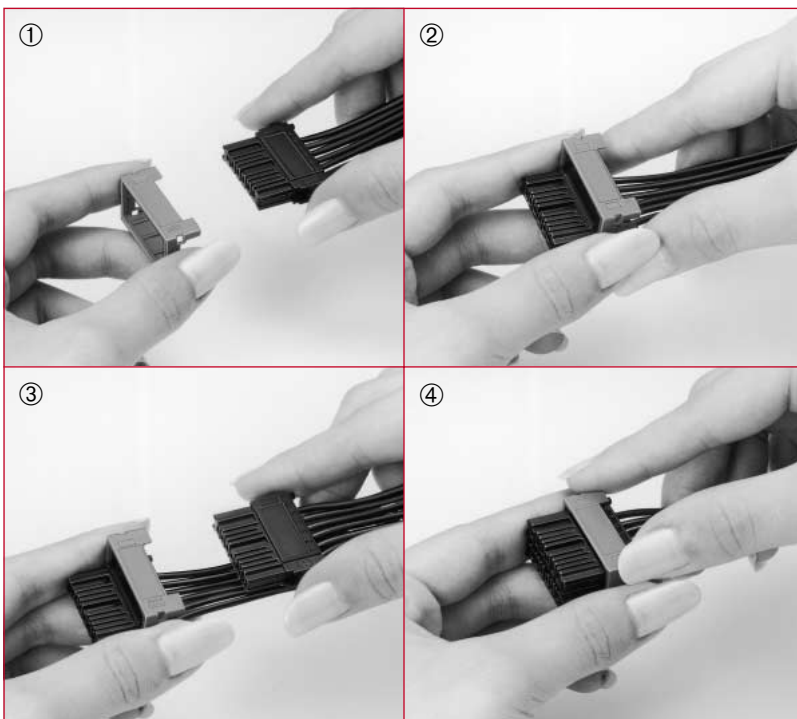

<Caution>The holder cover is not a rugged support fixture but only meant for alignment of the plugs. If external force is imposed by pulling of cables, etc. before mating, please bundle all cables together around the connector with union bands, etc.

◆ Installation method diagram

● 6-Position Type

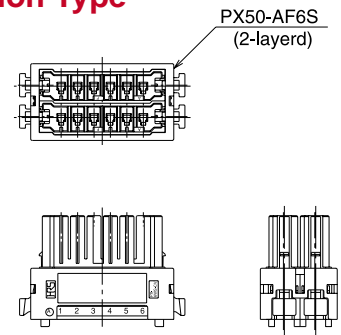

● 4-Position Type

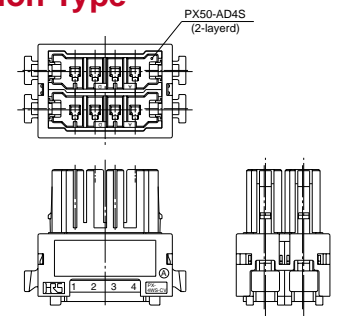

■Terminal

AWG No.	Delivery state	Product No.	CL No.	Packing volume
# 16, 18	Reeled	PX50-SC-231	CL236-0003-5	1 reel: 5000 cables
	Packed	PX50-SC-131	CL236-0008-9	1 pack: 100 cables

Please order by integral multiple of the packing volume.

■Crimping Tool

Description	Form	Product No.	CL No.	Adaptive terminal
Automatic	Auto crimper	CM-105	CL901-0005-4	PX50-SC-231
	Applicator	AP105-PX50-3	CL901-2573-8	
Manual	Hand tool (*)	HT104/PX50-3	CL250-0229-4	PX50-SC-131
Crimp terminal drawing jig		PX50-SC-TC	CL250-0233-1	PX50-SC-*31

* For our manual crimping tools, we employ the rotate-replace procedure to use the crimper depending on wire size.

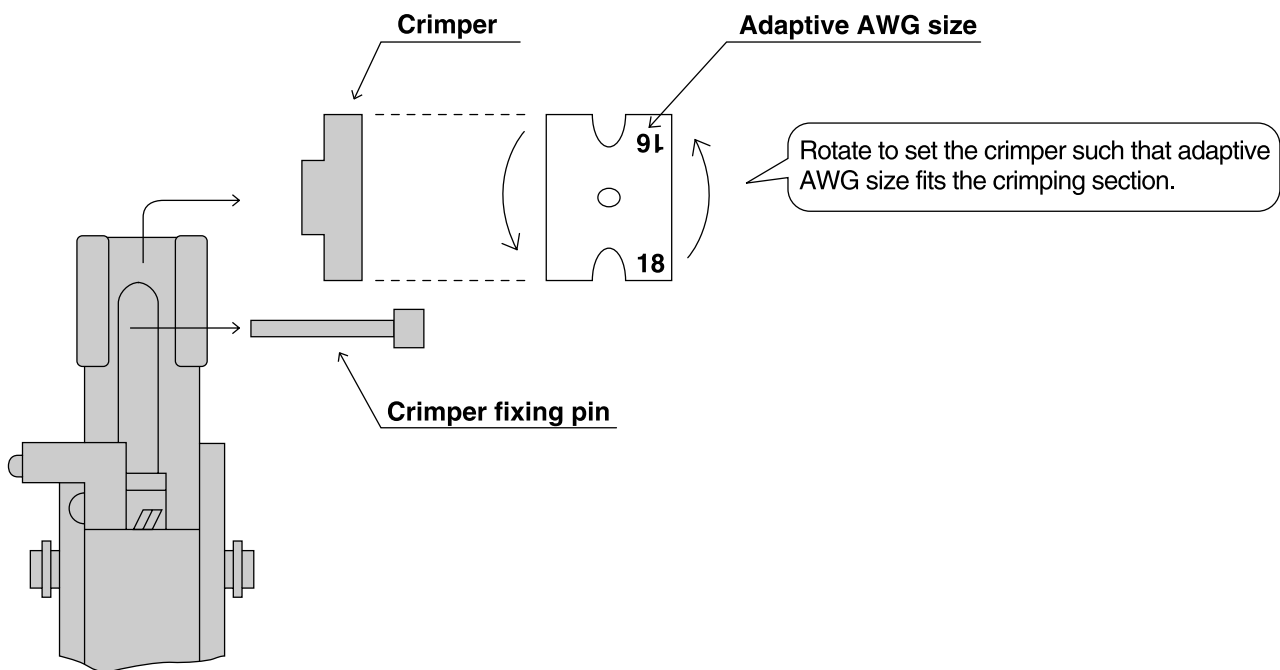

[Manual crimping tool : crimped section]

Note.) Since manual crimping tool cannot provide fine adjustment of crimp height, please use the proper crimp height of auto crimper in crimping of the wires other than specified ones

■Crimp Terminal Drawing Jig

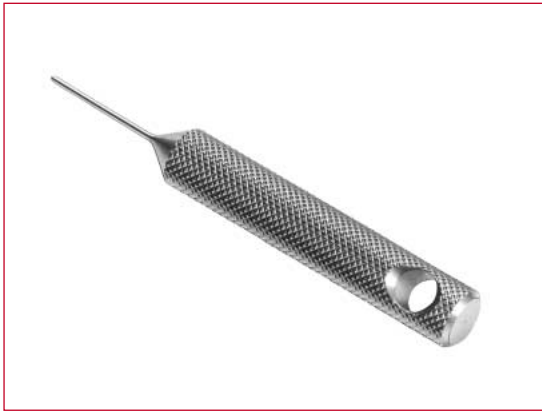

PX50-SC-TC CL250-0233-1

<WARNING>

When the crimp terminal drawing jig is inserted and pushed from the fitting section of a connector as shown below, retainer lock of the terminal will be released. Then please extract the cable. If the retainer is too lowered after extracting terminal, put it in a former position and reinsert. Position and direction of the jig top to be inserted are as shown in the Figures below. Be careful that any mistake will lead to the damage of terminal.

●How To Extract Crimp Terminal

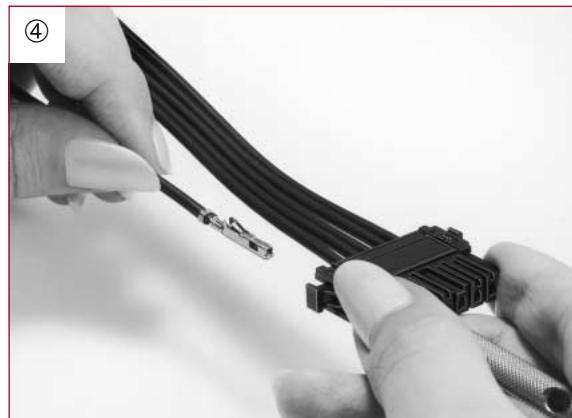

* Insert the jig top into the peak of convex section on terminal hole.

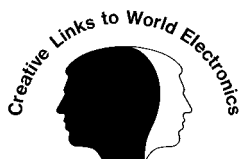

HIROSE ELECTRIC CO.,LTD.

5-23,OSAKI 5-CHOME,SHINAGAWA-KU,TOKYO 141-8586,JAPAN

PHONE:3-3491-9741

FAX :3-3493-2933