

35L SERIES**FASTEST, MOST FLEXIBLE
DESIGN RESPONSE****GENERAL SPECIFICATIONS**

Step Angle	7.5° / 15° / 18°
Step Accuracy	± 0.5° / ± 1° / ± 1.2°
Operating Temperature	100°C Max
Ambient Temperature Range	-20°C ~ +70°C
Insulation Resistance at 500Vdc	100MΩ
Dielectric Withstanding Voltage	650 ± 50 VRMS, 2 sec

 [CLICK HERE TO
PRINT THIS SERIES](#)
OPENS PDF IN NEW WINDOW

The specifications in this publication are believed to be accurate and reliable. However, it is the responsibility of the product user to determine the suitability of Portescap products for a specific application. While defective products will be replaced without charge if promptly returned, no liability is assumed beyond such replacement.

Portescap Danaher Motion motors will not be CE marked where the Low Voltage Directive, the Electro-Magnetic Compatibility or other appropriate EU directives are not applicable - this is an EU legal requirement.

TECHNICAL SPECIFICATIONS

	UNIPOLAR					
Part Number	35L020B1U-N	35L020B2U-N	35L024B1U-N	35L024B2U-N	35L048B1U-N	35L048B2U-N
DC Op. Voltage	5	12	5	12	5	12
Resistance per Winding (ohms)	11	64	11	64	11	64
Inductance per Winding (mH)	6.4	35	7.4	38	7.8	40
Holding Torque* (mNm/oz-in)	18.3 / 2.6	18.3 / 2.6	20 / 2.8	20 / 2.8	25 / 3.5	25 / 3.5
Rotor Moment of Inertia (g.m ²)	4 x 10 ⁻⁴	4 x 10 ⁻⁴	4 x 10 ⁻⁴	4 x 10 ⁻⁴	4 x 10 ⁻⁴	4 x 10 ⁻⁴
Detent Torque (mNm/oz-in)	4.2 / 0.60	4.2 / 0.60	4.2 / 0.60	4.2 / 0.60	4.2 / 0.60	4.2 / 0.60
Step Angle	18°	18°	15°	15°	7.5°	7.5°
Step Angle Tolerance*	± 1.2°	± 1.2°	± 1°	± 1°	± 0.5°	± 0.5°
Steps per Rev.*	20	20	24	24	48	48
Max. Operating Temp.	100°C	100°C	100°C	100°C	100°C	100°C
Ambient Temp. Range						
Operating	-20°C to 70°C	-20°C to 70°C	-20°C to 70°C	-20°C to 70°C	-20°C to 70°C	-20°C to 70°C
Storage	-40°C to 85°C	-40°C to 85°C	-40°C to 85°C	-40°C to 85°C	-40°C to 85°C	-40°C to 85°C
Bearing Type	Sintered bronze sleeve	Sintered bronze sleeve	Sintered bronze sleeve	Sintered bronze sleeve	Sintered bronze sleeve	Sintered bronze sleeve
Insulation Resistance at 500Vdc	100 megohms	100 megohms	100 megohms	100 megohms	100 megohms	100 megohms
Dielectric Withstanding Voltage	650 ± 50 VRMS, 2 sec	650 ± 50 VRMS, 2 sec	650 ± 50 VRMS, 2 sec	650 ± 50 VRMS, 2 sec	650 ± 50 VRMS, 2 sec	650 ± 50 VRMS, 2 sec
Weight (g/oz)	88 / 3.1	88 / 3.1	88 / 3.1	88 / 3.1	88 / 3.1	88 / 3.1
Leadwires	26 AWG, UL Style 1430	26 AWG, UL Style 1430	26 AWG, UL Style 1430	26 AWG, UL Style 1430	26 AWG, UL Style 1430	26 AWG, UL Style 1430

* Measured with 2 phases energized

TECHNICAL SPECIFICATIONS

	BIPOLAR					
Part Number	35L020B1B-N	35L020B2B-N	35L024B1B-N	35L024B2B-N	35L048B1B-N	35L048B2B-N
DC Op. Voltage	5	12	5	12	5	12
Resistance per Winding (ohms)	11	64	11	64	11	64
Inductance per Winding (mH)	13.2	60	14.2	65	15	72
Holding Torque* (mNm/oz-in)	21.8 / 3.3	21.8 / 3.3	25 / 3.5	25 / 3.5	28 / 4.0	28 / 4.0
Rotor Moment of Inertia (g.m ²)	4 x 10 ⁻⁴	4 x 10 ⁻⁴	4 x 10 ⁻⁴	4 x 10 ⁻⁴	4 x 10 ⁻⁴	4 x 10 ⁻⁴
Detent Torque (mNm/oz-in)	4.2 / 0.60	4.2 / 0.60	4.2 / 0.60	4.2 / 0.60	4.2 / 0.60	4.2 / 0.60
Step Angle	18°	18°	15°	15°	7.5°	7.5°
Step Angle Tolerance*	± 1.2°	± 1.2°	± 1°	± 1°	± 0.5°	± 0.5°
Steps per Rev.*	20	20	24	24	48	48
Max. Operating Temp.	100°C	100°C	100°C	100°C	100°C	100°C
Ambient Temp. Range						
Operating	-20°C to 70°C	-20°C to 70°C	-20°C to 70°C	-20°C to 70°C	-20°C to 70°C	-20°C to 70°C
Storage	-40°C to 85°C	-40°C to 85°C	-40°C to 85°C	-40°C to 85°C	-40°C to 85°C	-40°C to 85°C
Bearing Type	Sintered bronze sleeve	Sintered bronze sleeve	Sintered bronze sleeve	Sintered bronze sleeve	Sintered bronze sleeve	Sintered bronze sleeve
Insulation Resistance at 500Vdc	100 megohms	100 megohms	100 megohms	100 megohms	100 megohms	100 megohms
Dielectric Withstanding Voltage	650 ± 50 VRMS, 2 sec	650 ± 50 VRMS, 2 sec	650 ± 50 VRMS, 2 sec	650 ± 50 VRMS, 2 sec	650 ± 50 VRMS, 2 sec	650 ± 50 VRMS, 2 sec
Weight (g/oz)	88 / 3.1	88 / 3.1	88 / 3.1	88 / 3.1	88 / 3.1	88 / 3.1
Leadwires	26 AWG, UL Style 1430	26 AWG, UL Style 1430	26 AWG, UL Style 1430	26 AWG, UL Style 1430	26 AWG, UL Style 1430	26 AWG, UL Style 1430

* Measured with 2 phases energized

MECHANICAL DIMENSIONS

UNITS = MM / INCHES

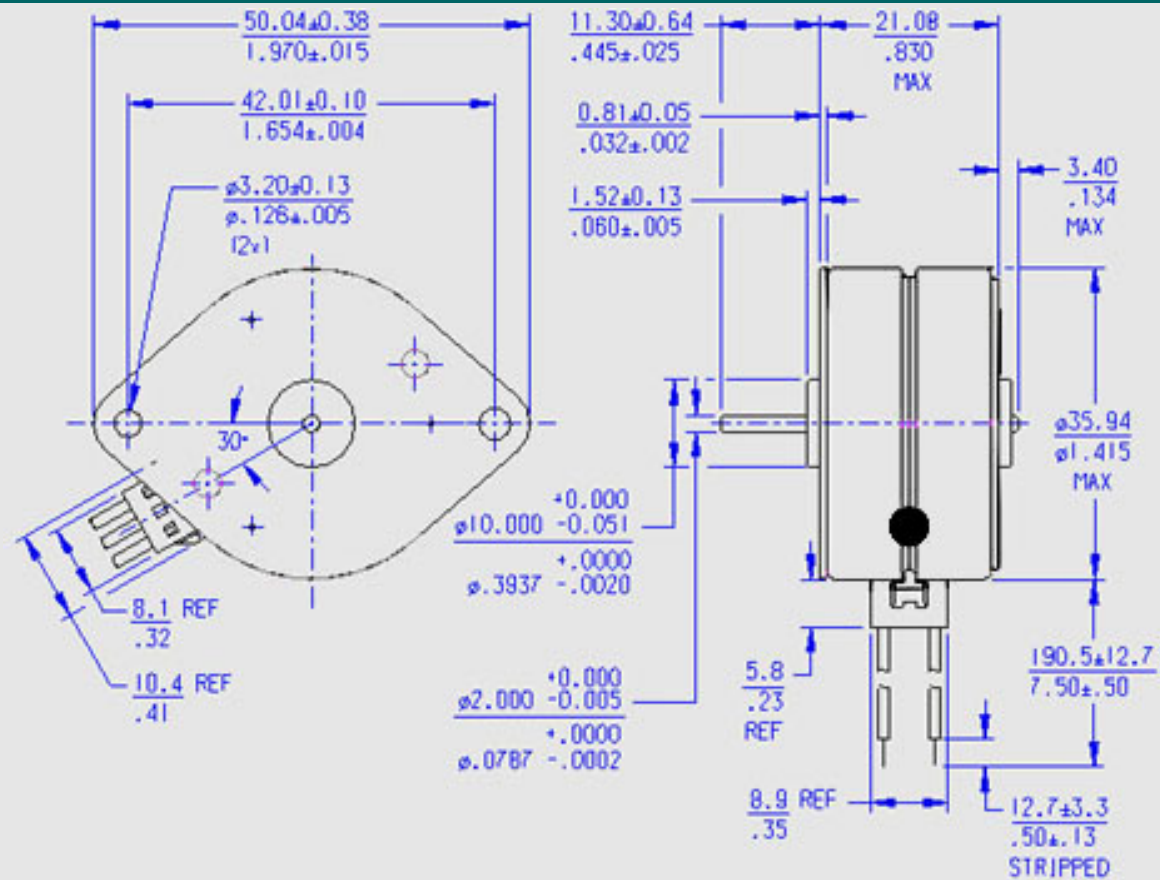

WIRING DIAGRAM

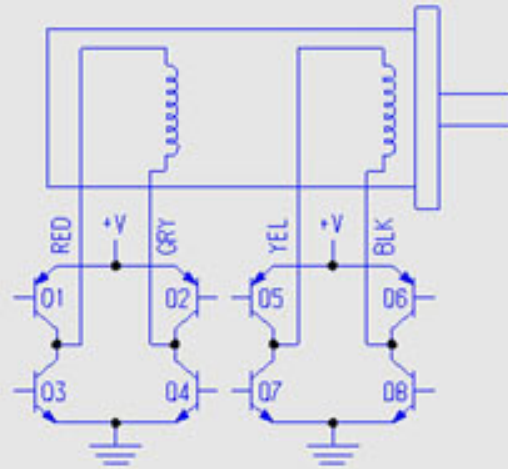

BIPOLAR

STEP	01-04	02-03	05-08	06-07
1	ON	OFF	ON	OFF
2	ON	OFF	OFF	ON
3	OFF	ON	OFF	ON
4	OFF	ON	ON	OFF
1	ON	OFF	ON	OFF

CW ROTATION ↓

↑ CCW ROTATION

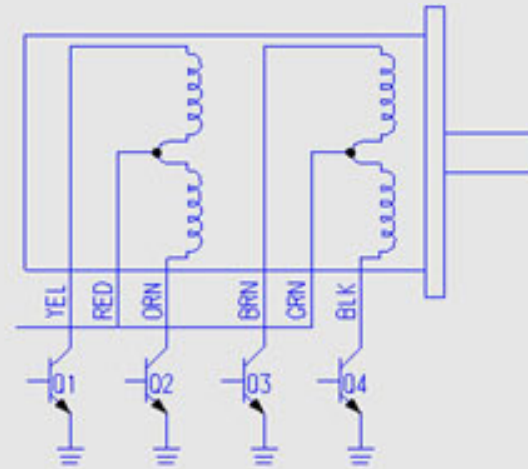

UNIPOLAR

STEP	01	02	03	04
1	ON	OFF	ON	OFF
2	ON	OFF	OFF	ON
3	OFF	ON	OFF	ON
4	OFF	ON	ON	OFF
1	ON	OFF	ON	OFF

CW ROTATION ↓

↑ CCW ROTATION

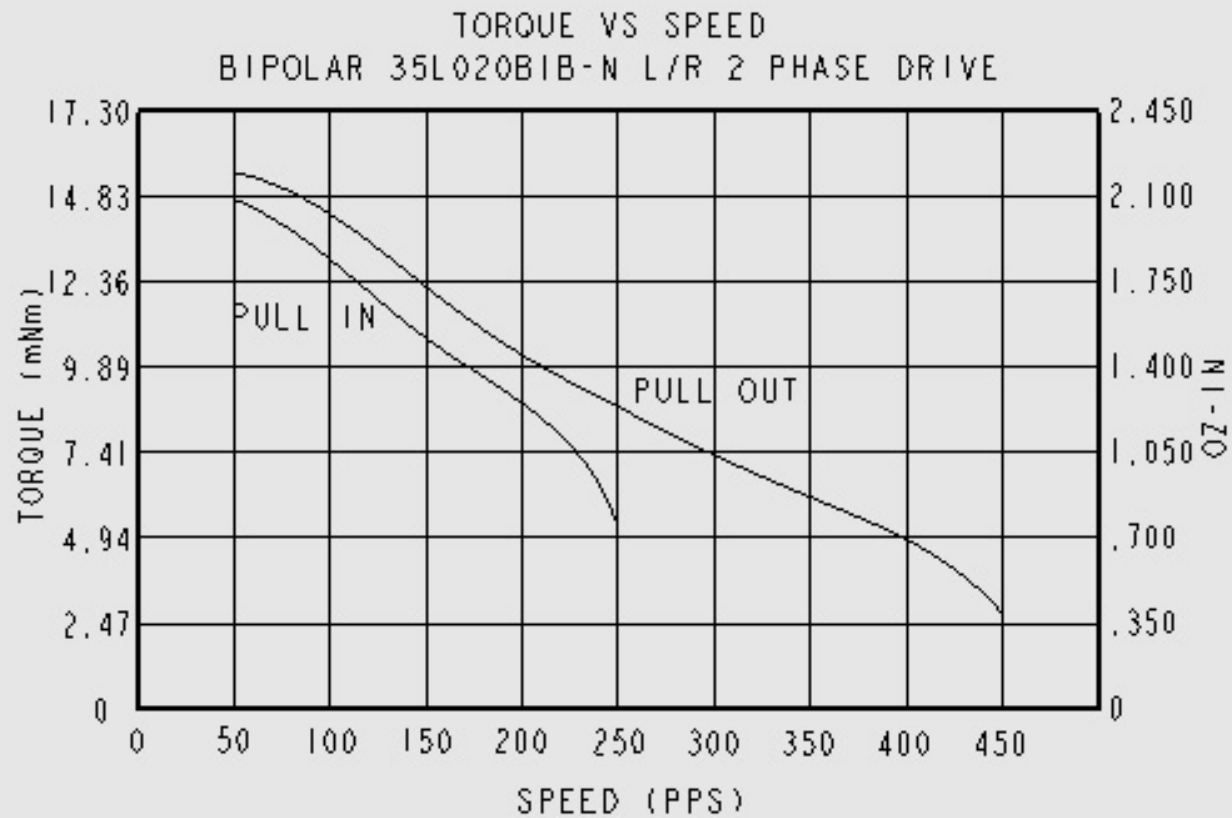

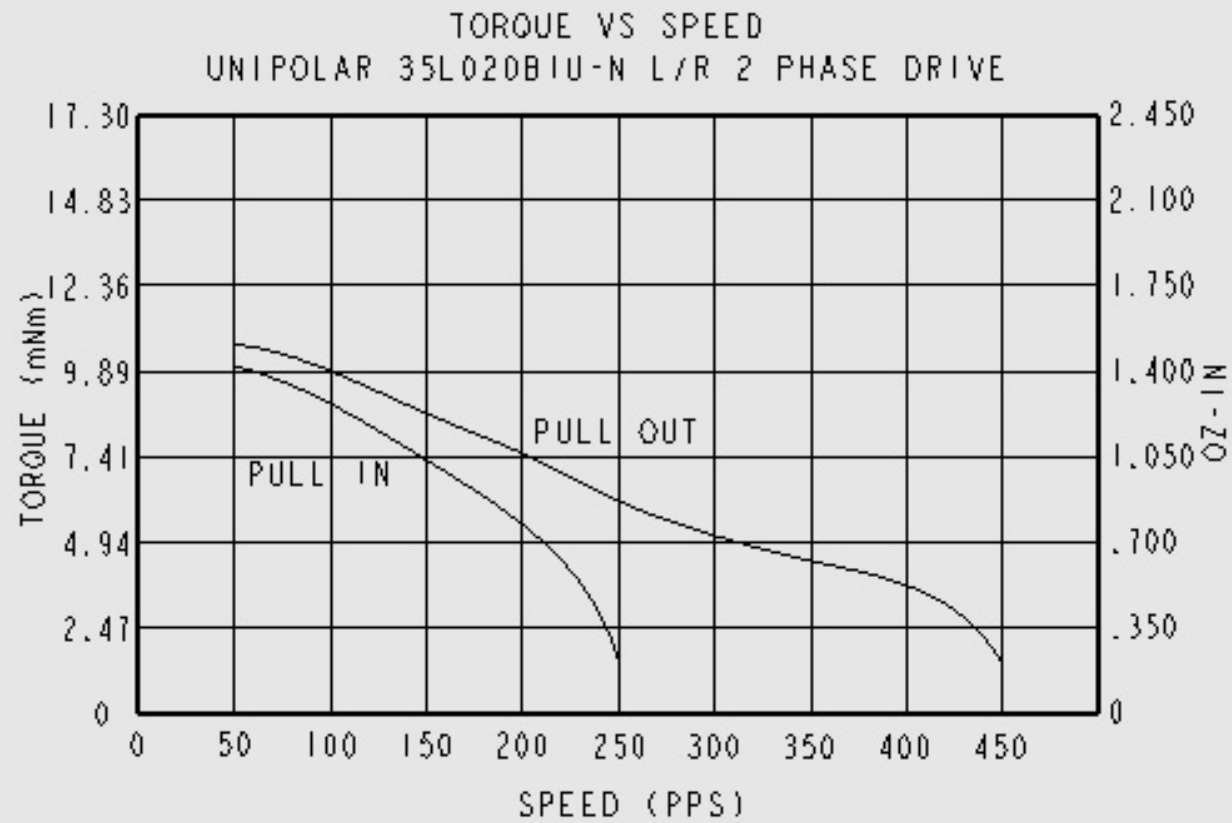

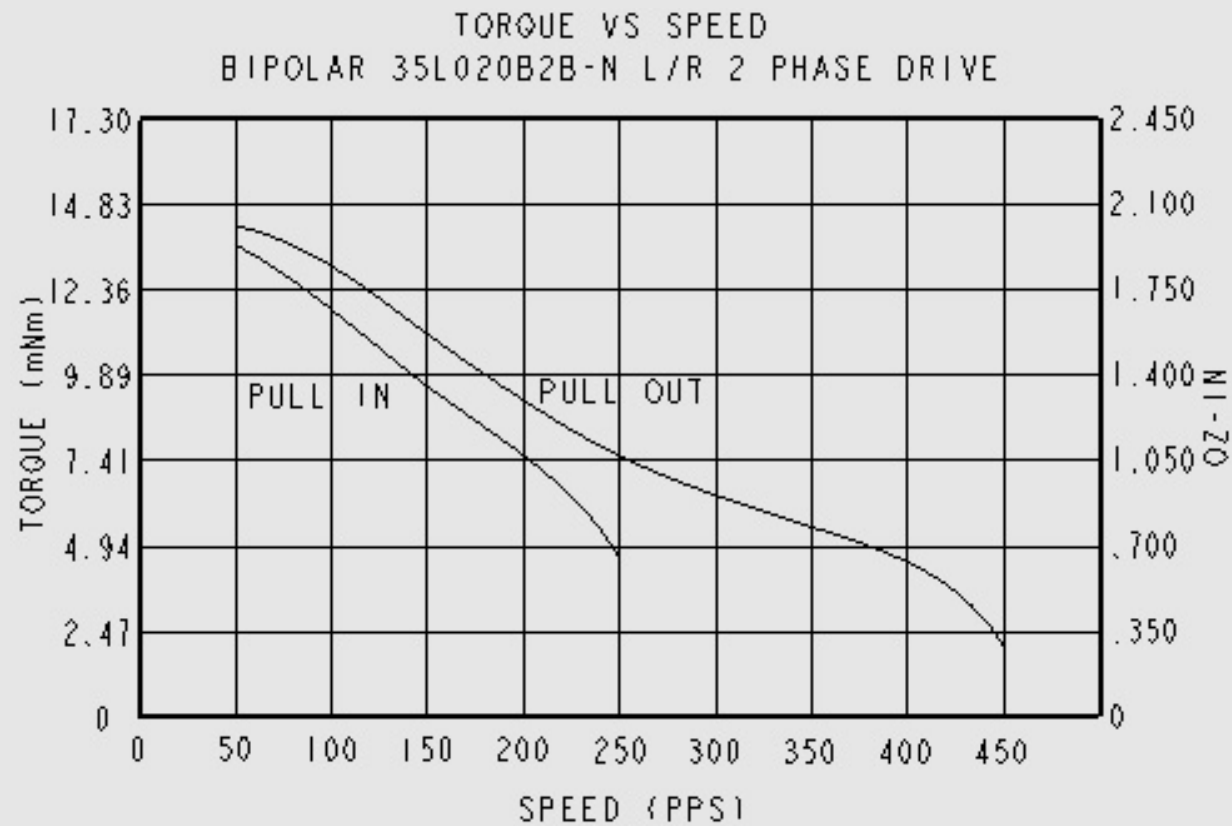

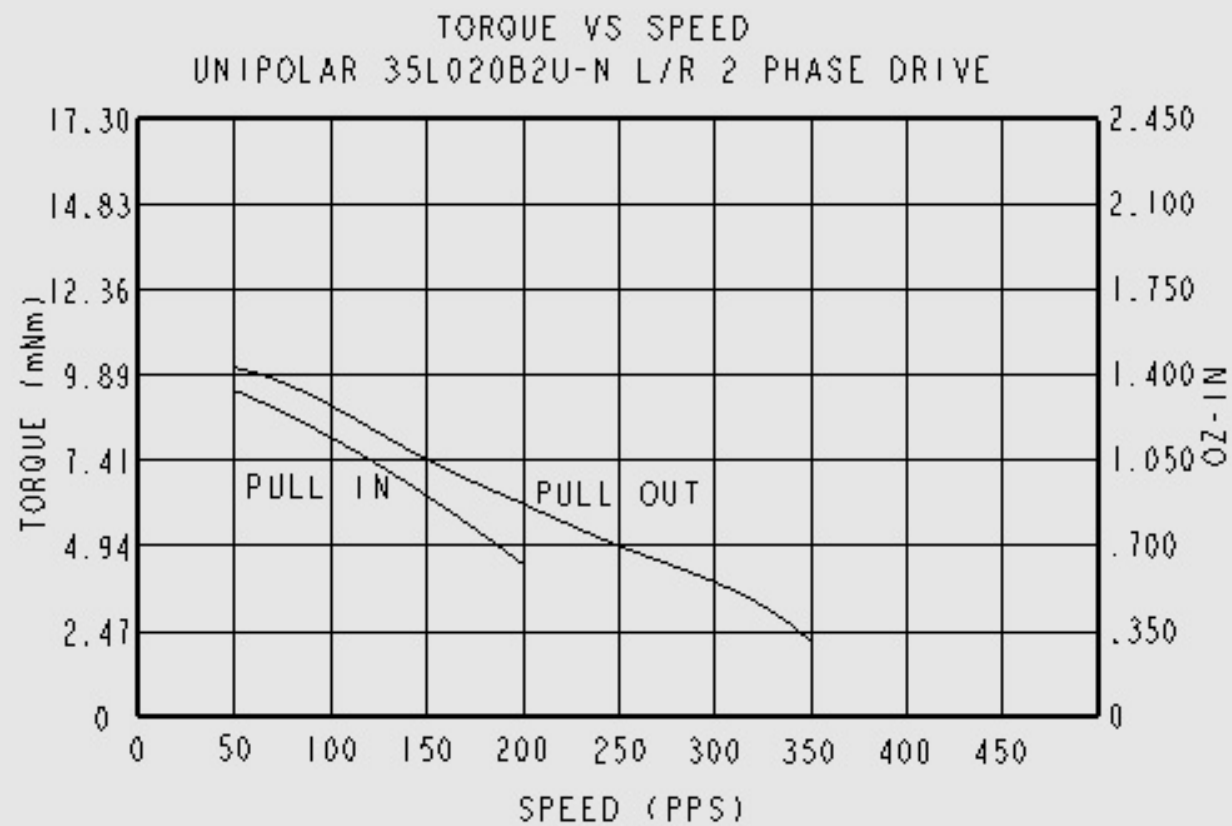

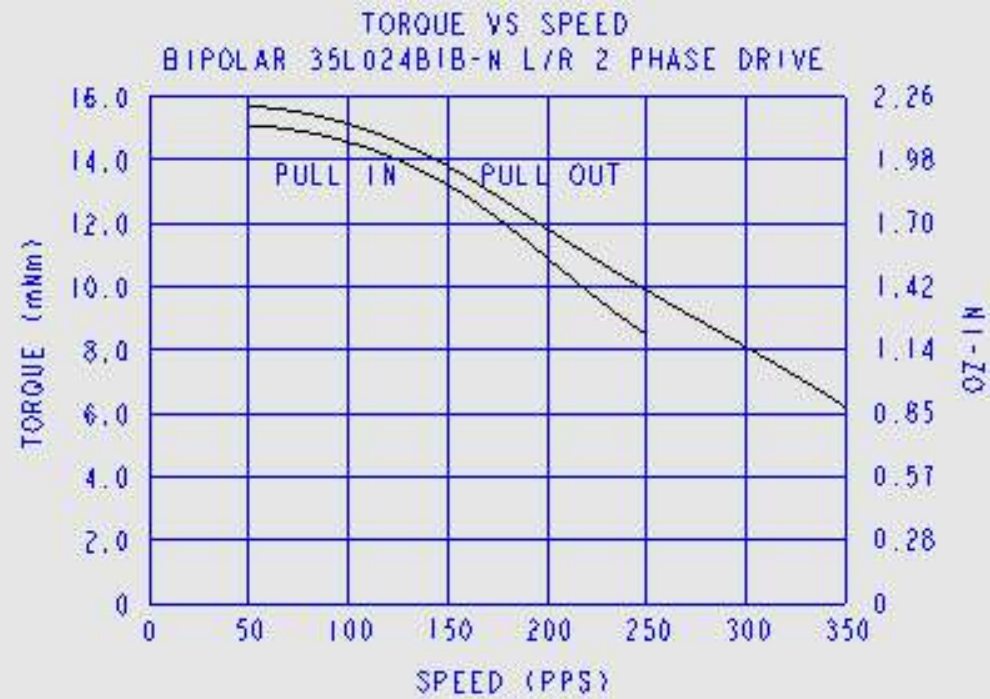

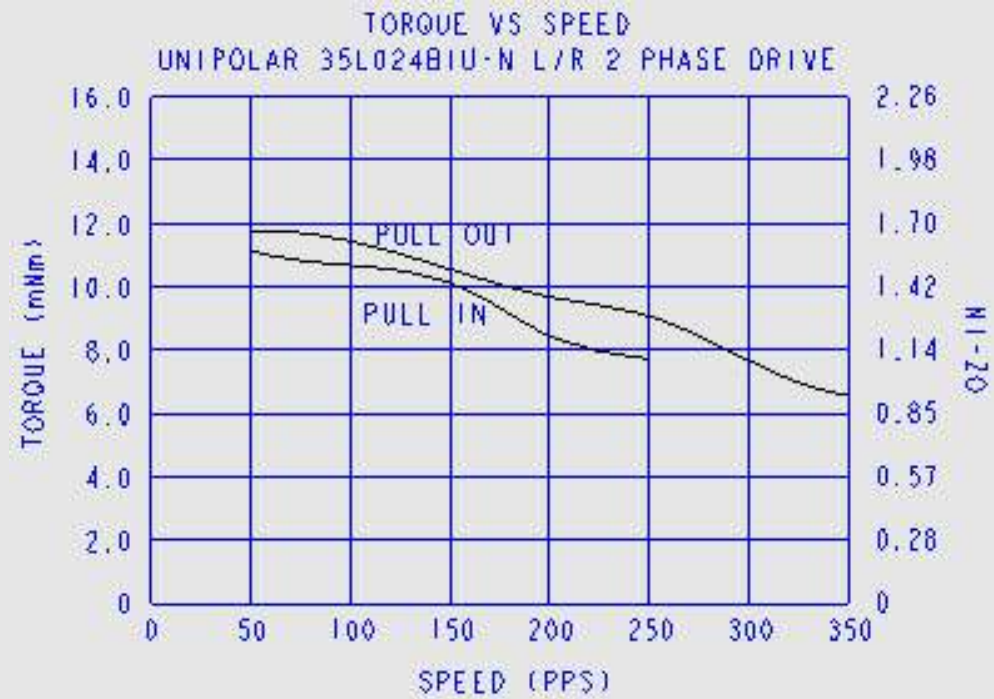

MOTOR DYNAMICS



CHART INDEX

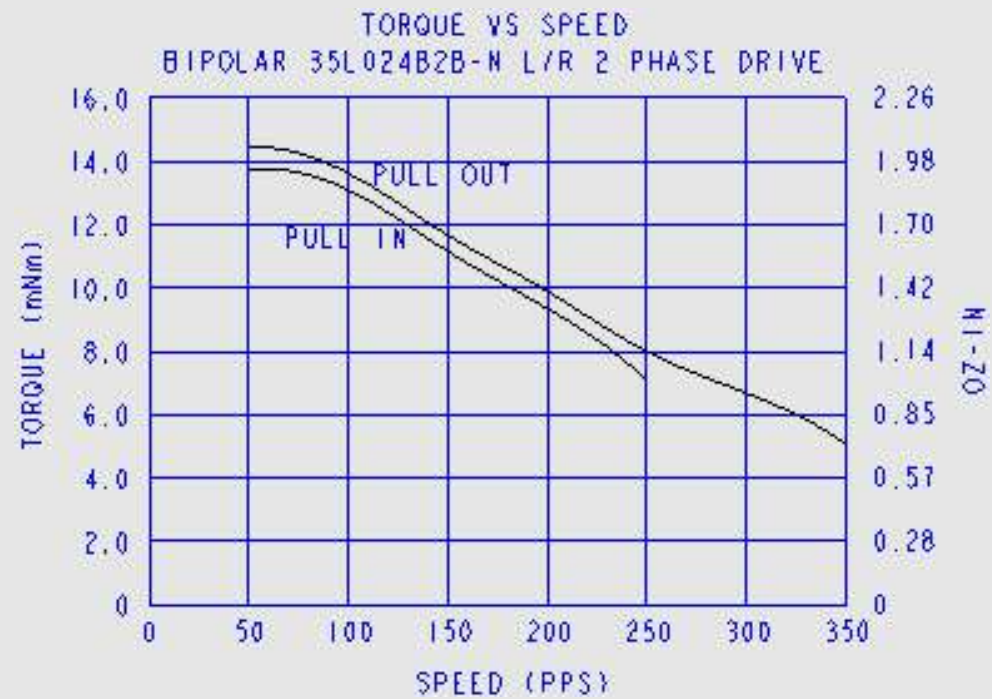

MOTOR DYNAMICS



CHART INDEX

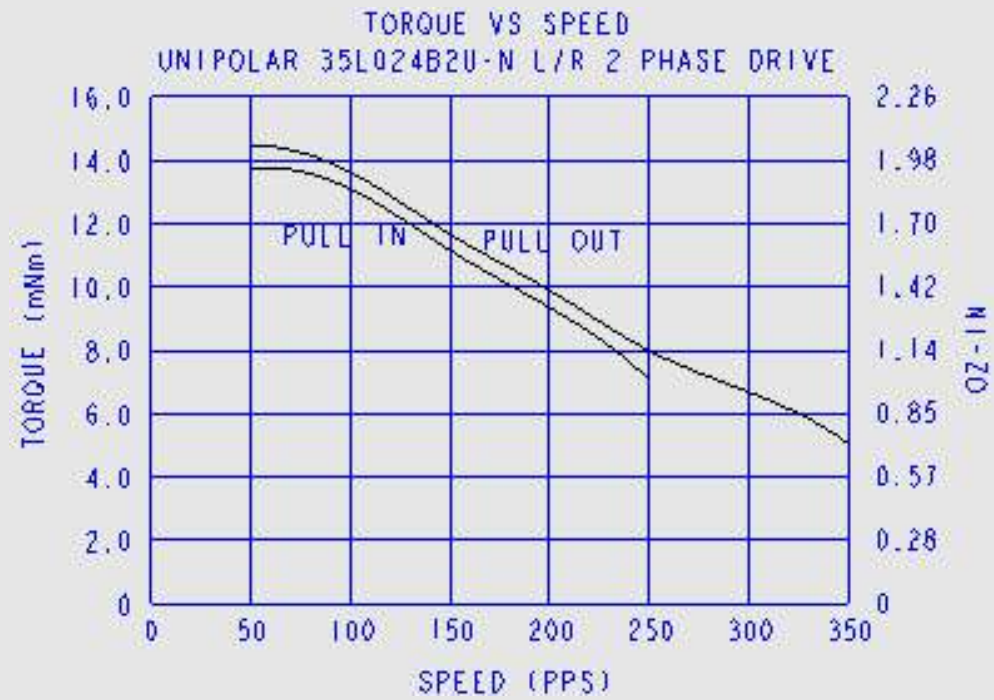

MOTOR DYNAMICS



CHART INDEX

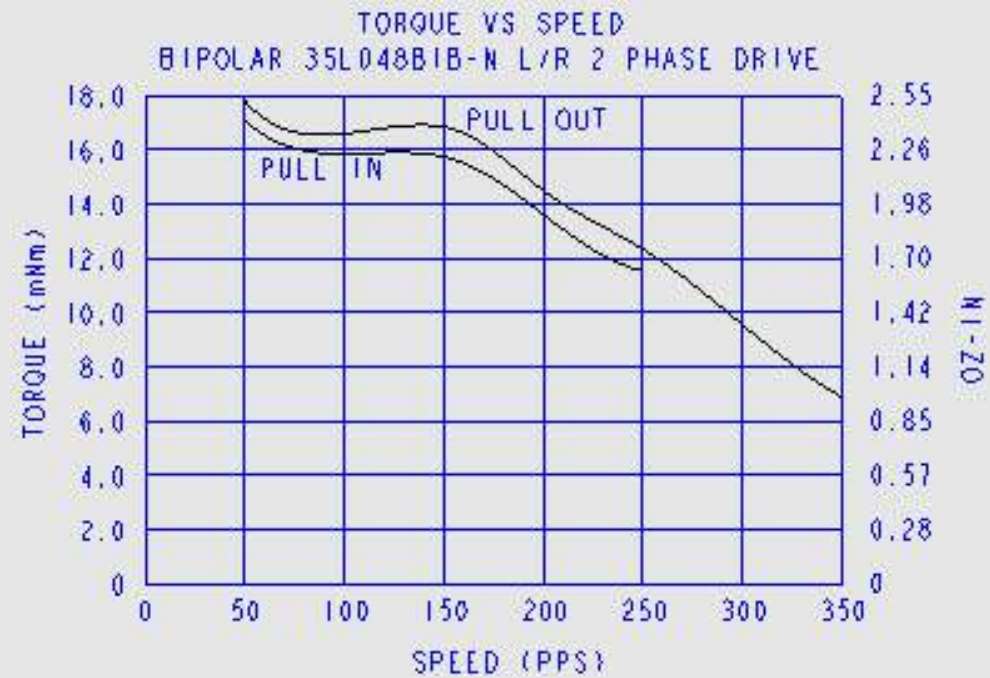

MOTOR DYNAMICS



CHART INDEX

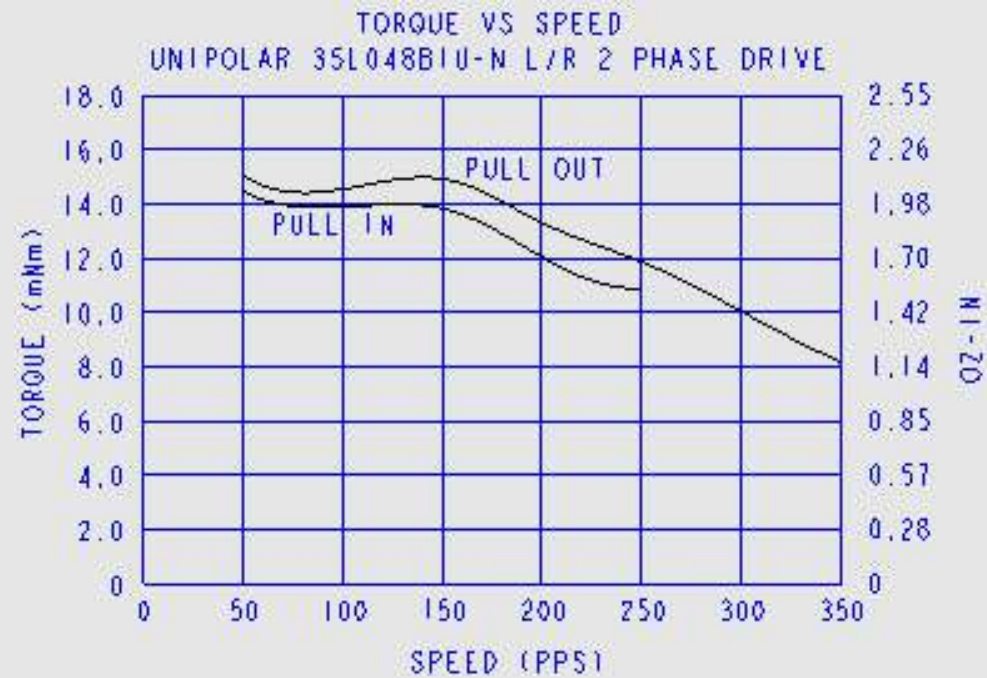

MOTOR DYNAMICS



CHART INDEX

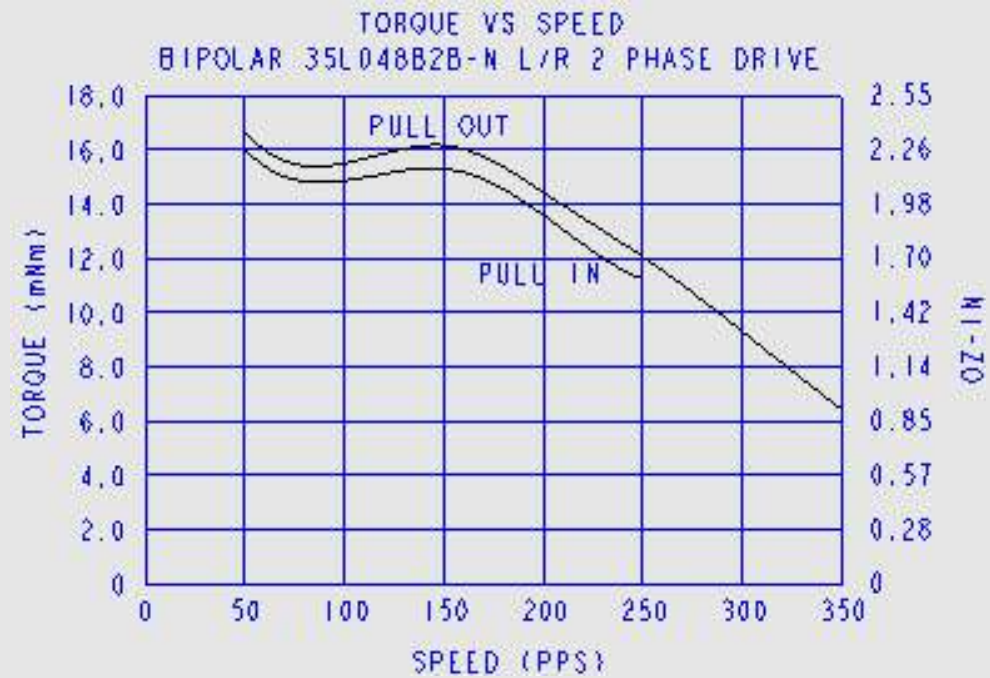

MOTOR DYNAMICS



CHART INDEX

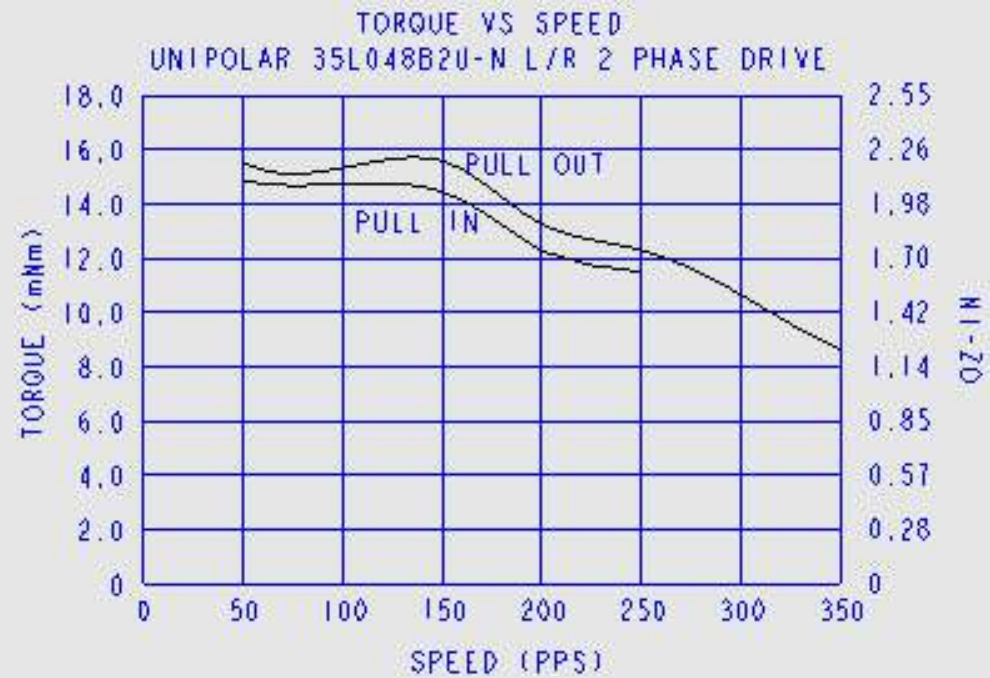



TORQUE VS SPEED

BIPOLAR 35L020B1B CHOPPER DRIVE
@ 36V, 300mA/ϕ, 2ϕ





TORQUE VS SPEED

BIPOLAR 35L024BIB CHOPPER DRIVE
@ 36V, 300mA/ϕ, 2ϕ

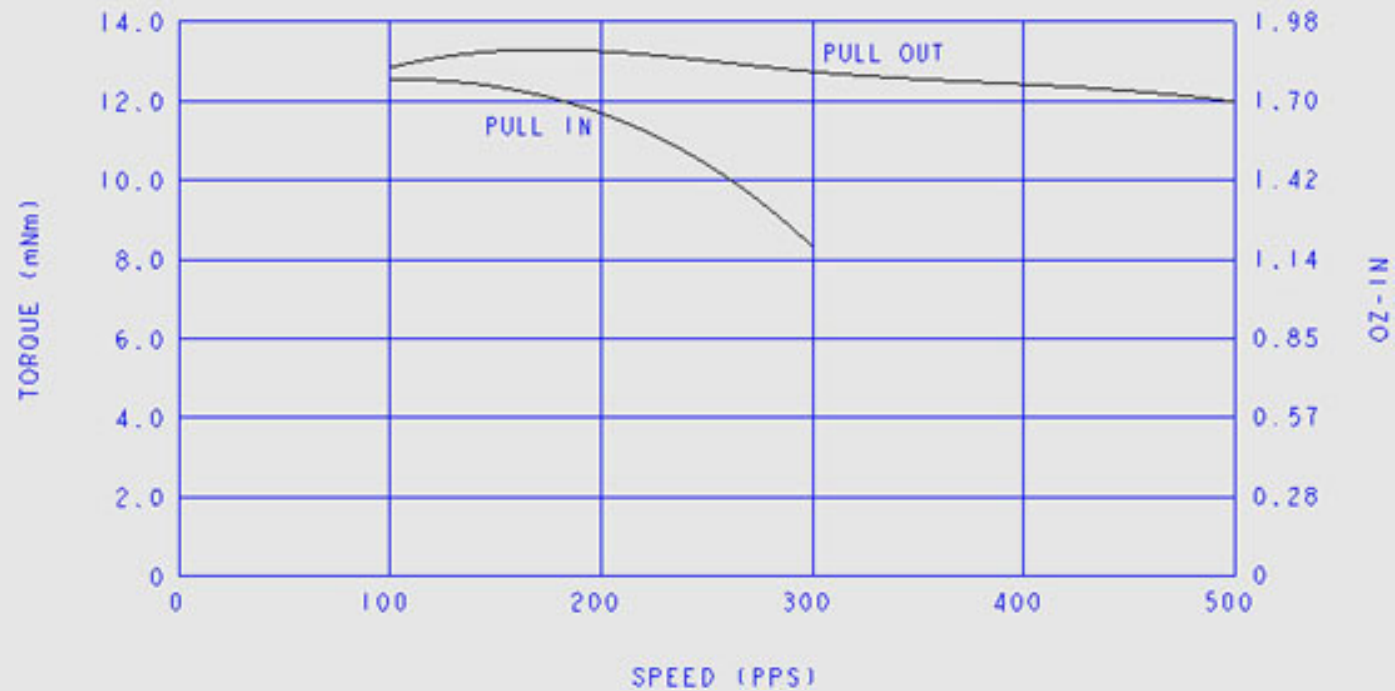



TORQUE VS SPEED

BIPOLAR 35L048B1B CHOPPER DRIVE
⊗ 36V, 300mA/ϕ, 2ϕ

