

ARF461A(G) ARF461B(G)

RF POWER MOSFETs N-CHANNEL ENHANCEMENT MODE

250V 150W 65MHz

The ARF461A and ARF461B comprise a symmetric pair of common drain RF power transistors designed for push-pull scientific, commercial, medical and industrial RF power amplifier applications up to 65 MHz. They have been optimized for both linear and high efficiency classes of operation.

- **Specified 250 Volt, 40.68 MHz Characteristics:**
 - Output Power = 150 Watts.**
 - Gain = 13dB (Class AB)**
 - Efficiency = 75% (Class C)**
- **Low Cost Common Source RF Package.**
- **Low Vth thermal coefficient.**
- **Low Thermal Resistance.**
- **Optimized SOA for Superior Ruggedness.**
- **RoHS Compliant** 

MAXIMUM RATINGS

All Ratings: $T_C = 25^\circ\text{C}$ unless otherwise specified.

Symbol	Parameter	ARF461AG/BG	Unit
V_{DSS}	Drain-Source Voltage	1000	V
V_{DGO}	Drain-Gate Voltage	1000	
I_D	Continuous Drain Current @ $T_C = 25^\circ\text{C}$	6.5	A
V_{GS}	Gate-Source Voltage	± 30	V
P_D	Total Power Dissipation @ $T_C = 25^\circ\text{C}$	250	W
$R_{\theta JC}$	Junction to Case	0.50	$^\circ\text{C}/\text{W}$
T_J, T_{STG}	Operating and Storage Junction Temperature Range	-55 to 150	$^\circ\text{C}$
T_L	Lead Temperature: 0.063" from Case for 10 Sec.	300	

STATIC ELECTRICAL CHARACTERISTICS

Symbol	Parameter	Min	Typ	Max	Unit
BV_{DSS}	Drain-Source Breakdown Voltage ($V_{GS} = 0\text{V}, I_D = 250 \mu\text{A}$)	1000			V
$V_{DS(ON)}$	On State Drain Voltage ¹ ($I_{D(ON)} = 3.25\text{A}, V_{GS} = 10\text{V}$)			6.5	
I_{DSS}	Zero Gate Voltage Drain Current ($V_{DS} = V_{DSS}, V_{GS} = 0\text{V}$)			25	μA
	Zero Gate Voltage Drain Current ($V_{DS} = 0.8V_{DSS}, V_{GS} = 0, T_C = 125^\circ\text{C}$)			250	
I_{GSS}	Gate-Source Leakage Current ($V_{DS} = \pm 30\text{V}, V_{GS} = 0\text{V}$)			± 100	nA
g_{fs}	Forward Transconductance ($V_{DS} = 25\text{V}, I_D = 3.25\text{A}$)	3	4		mhos
$V_{GS(TH)}$	Gate Threshold Voltage ($V_{DS} = V_{GS}, I_D = 50\text{mA}$)	3		5	Volts



CAUTION: These Devices are Sensitive to Electrostatic Discharge. Proper Handling Procedures Should Be Followed.

Dynamic Characteristics

ARF461A/B

Symbol	Parameter	Test Conditions	Min	Typ	Max	Unit
C_{iss}	Input Capacitance	$V_{GS} = 0V$ $V_{DS} = 50V$ $f = 1MHz$		1700		pF
C_{oss}	Output Capacitance			175		
C_{rss}	Reverse Transfer Capacitance			50		
$t_{d(on)}$	Turn-On Delay Time	$V_{GS} = 15V$ $V_{DD} = 0.5V_{DSS}$ $I_D = I_{D(Cont.)} @ 25^{\circ}C$ $R_G = 1.6\Omega$		8		ns
t_r	Rise Time			5		
$t_{d(off)}$	Turn-off Delay Time			21		
t_f	Fall Time			10.1		

Functional Characteristics

Symbol	Characteristic	Test Conditions	Min	Typ	Max	Unit
G_{PS}	Common Source Amplifier Power Gain	$f = 40.68MHz$ $V_{GS} = 0V$ $V_{DD} = 250V$ $P_{OUT} = 150W$	13	15		dB
η	Drain Efficiency		70	75		%
Ψ	Electrical Ruggedness VSWR 10:1		No Degradation in Output Power			

① Pulse Test: Pulse width < 380 μ S, Duty Cycle < 2%

APT Reserves the right to change, without notice, the specifications and information contained herein.

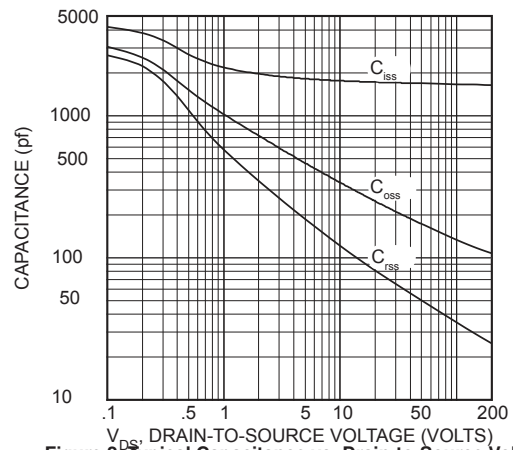

Figure 2, Typical Capacitance vs. Drain-to-Source Voltage

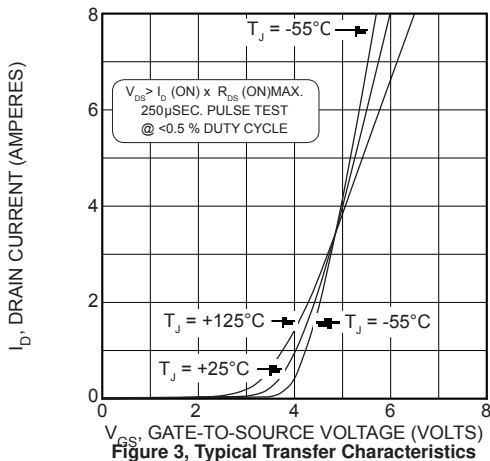

Figure 3, Typical Transfer Characteristics

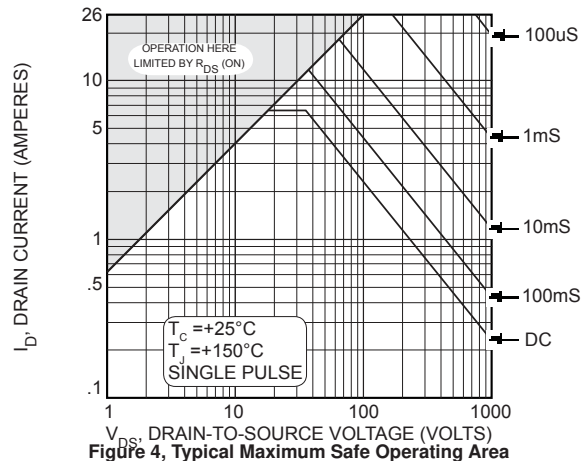

Figure 4, Typical Maximum Safe Operating Area

ARF461A/B

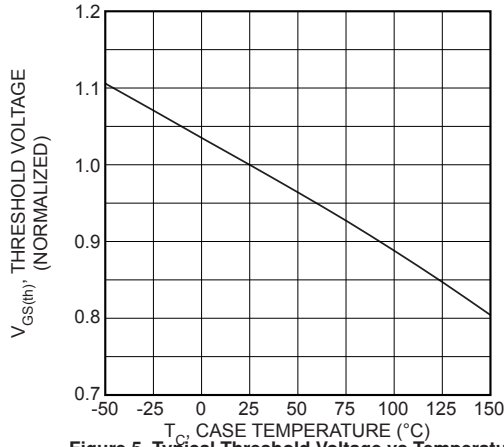

Figure 5, Typical Threshold Voltage vs Temperature

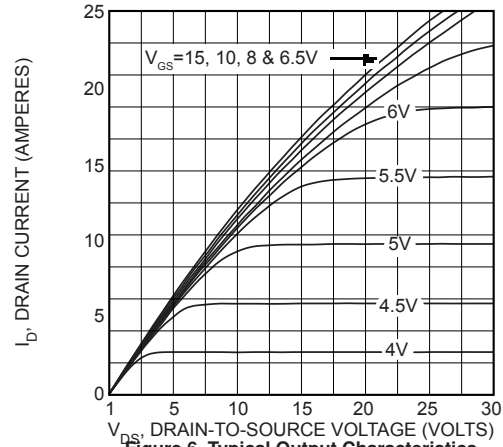

Figure 6, Typical Output Characteristics

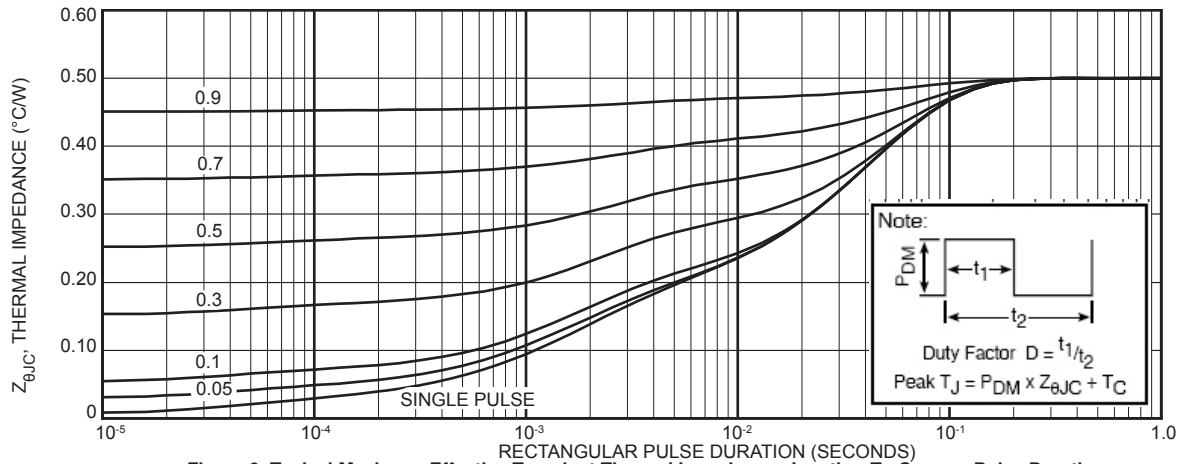

Figure 9, Typical Maximum Effective Transient Thermal Impedance, Junction-To-Case vs Pulse Duration

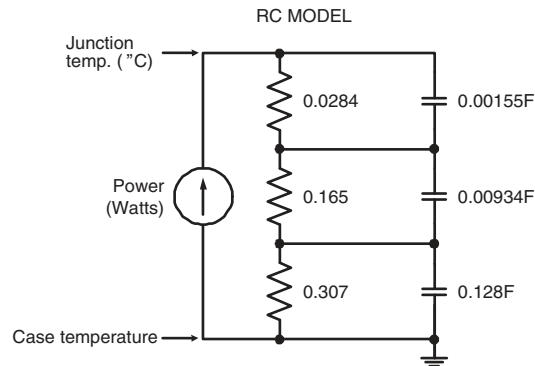

Figure 9a, TRANSIENT THERMAL IMPEDANCE MODEL

Table 1 - Typical Class AB Large Signal Input - Output Impedance

Freq. (MHz)	Z _{in} (Ω)	Z _{OL} (Ω)
2.0	20.9 - j 9.2	38 - j 2.6
13.5	2.4 - j 6.8	31 - j 14
27	.57 - j 2.6	19.6 - j 17.6
40	.31 - j 0.5	12.5 - j 15.8
65	.44 + j 1.9	6.0 - j 10.5

Z_{in} - Gate shunted with 25Ω

I_{DQ} = 100mA

Z_{OL} - Conjugate of optimum load for 150 Watts output at V_{dd} = 125V

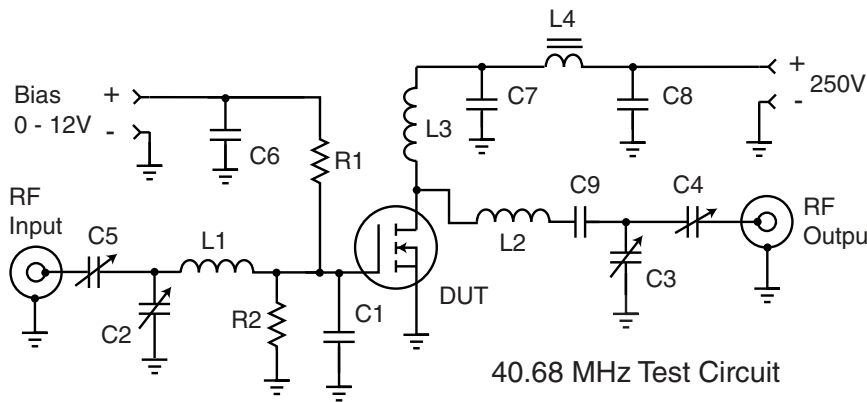

- C1 -- 1800pF + 1000pF 100V chips mounted at gate lead
- C2-C5 -- Arco 463 Mica trimmer
- C6-C8 -- .1 μF 500V ceramic chip
- C9 -- 2200 pF 500 V chip
- L1 -- 4t #20 AWG .25"ID .3 "L ~80nH
- L2 -- 7t #16 AWG .4" ID .5"L ~335nH
- L3 -- 25t #24 AWG .25"ID ~2.2uH
- L4 -- VK200-4B ferrite choke 3uH
- R1-R2 -- 51 Ohm 0.5W Carbon
- DUT = ARF461A/B

TO-247 Package Outline

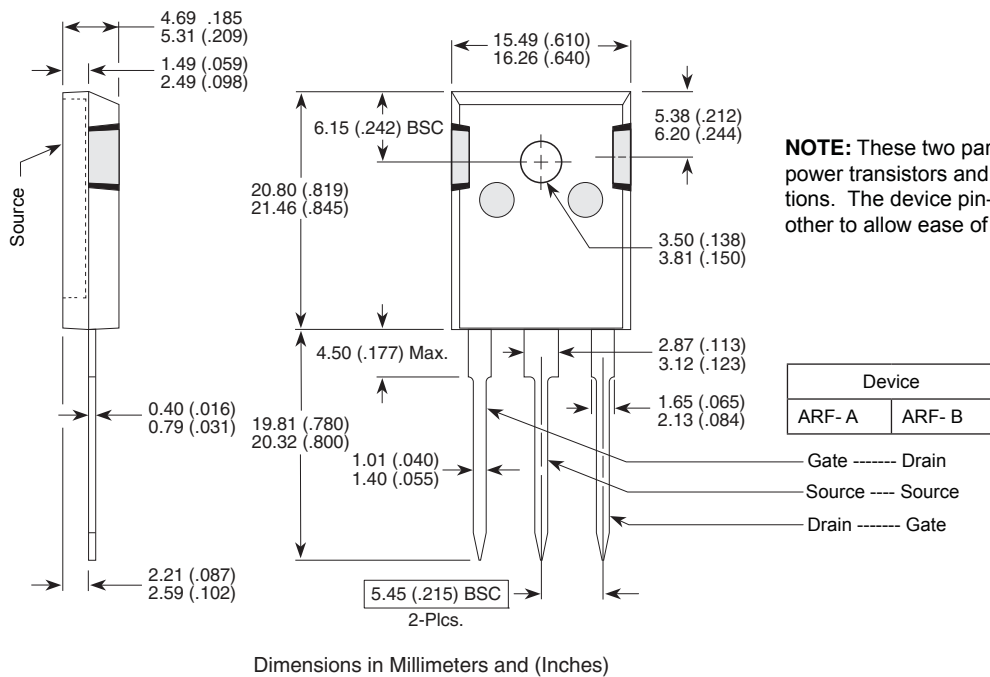

NOTE: These two parts comprise a symmetric pair of RF power transistors and meet the same electrical specifications. The device pin-outs are the mirror image of each other to allow ease of use as a push-pull pair.