

PATENT NUMBER
6159045

TSH-1XX-XX-XX-XX-XX-X-XX

No OF POSITIONS
-DH ROW SPEC:
-05 THRU -35
-RA ROW SPEC:
-05 THRU -48
(PER ROW)
[INCREMENTS OF 5 STD]

PACKAGING
BLANK: TUBES (SEE NOTE 12)
-TR: TAPE & REEL (-DH ONLY)
(SEE NOTES 13 & 14)
-FR: FULL REEL QTY TAPE & REEL
(-DH ONLY) (SEE NOTES 13 & 14)

PICK & PLACE OPTION
-K: POLYIMIDE FILM
(10 POS MIN)
(USE K-DOT-.177-.281-.005, SEE FIG 3,
SHT 3)
(NOT AVAILABLE ON -RA)
(NOT AVAILABLE ON 15 THRU
30 POSITIONS, SEE NOTE FIG 3)

OPTION
-SL: SOLDER LOCKS

ROW SPECIFICATION
-DH: DOUBLE HORIZONTAL (SEE FIG 1)
-RA: RIGHT ANGLE (SEE FIG 2, SHT 3)

PLATING SPECIFICATION

- G: 20µ" GOLD IN CONTACT AREA,
3µ" GOLD ON TAIL
- T: MATTE TIN CONTACT AND TAIL
- S: 30µ" SELECTIVE GOLD IN CONTACT AREA,
MATTE TIN ON TAIL
- L: 10µ" SELECTIVE GOLD IN CONTACT AREA,
MATTE TIN ON TAIL
- H: 30µ" GOLD IN CONTACT AREA,
3µ" GOLD ON TAIL
- F: 3µ" SELECTIVE GOLD IN CONTACT AREA,
MATTE TIN ON TAIL
- TM: MATTE TIN CONTACT AND TAIL
- SM: 30µ" SELECTIVE GOLD IN CONTACT AREA,
MATTE TIN ON TAIL
- LM: 10µ" SELECTIVE GOLD IN CONTACT AREA,
MATTE TIN ON TAIL
- FM: 3µ" SELECTIVE GOLD IN CONTACT AREA,
MATTE TIN ON TAIL

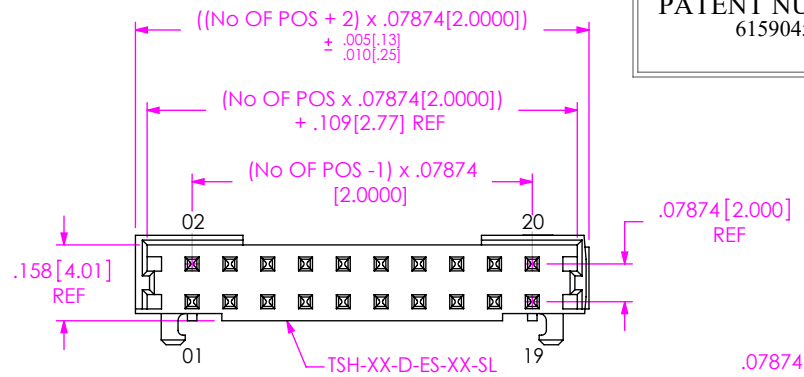

DO NOT
SCALE FROM
THIS PRINT

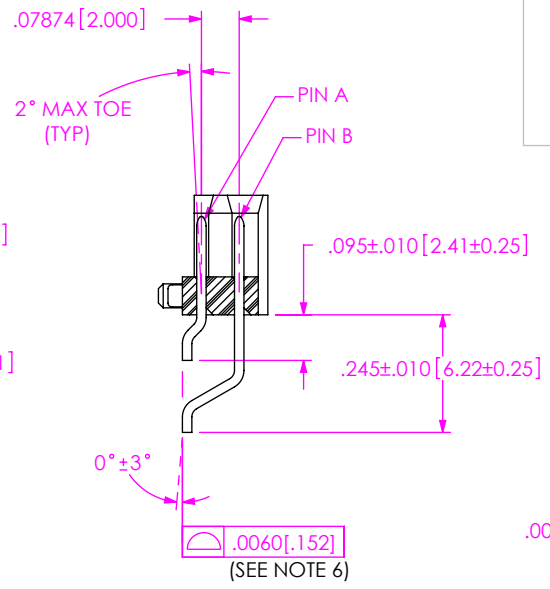
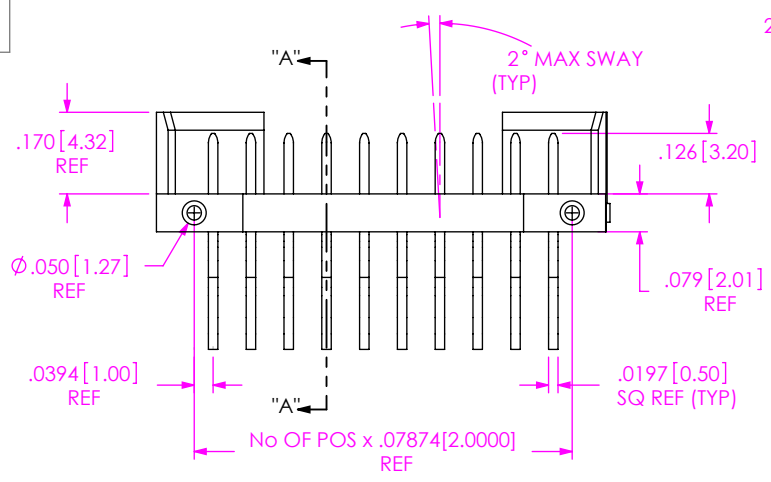

SECTION "A"- "A"

.000±.003 [0.00±0.08]
(SEE NOTE 11)

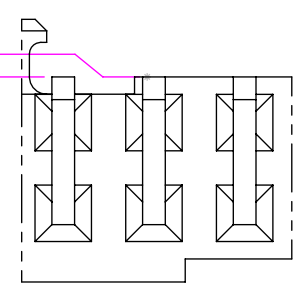

DETAIL 'E'
SCALE 6 : 1

STYLE	PIN A	PIN B
-DH	T-1S13-09-XX-2	T-1S13-09-XX-2
-RA	T-1S13-02-XX-2	T-1S13-03-XX-2

FIG 1
-DH: DOUBLE HORIZONTAL
TSH-110-01-XX-DH-SL SHOWN
(AVAILABLE IN POSITIONS -05 THRU -35)

- NOTES:
- REPRESENTS A CRITICAL DIMENSION.
 - MAX BURR ALLOWANCE: .002 [.05].
 - MAX CUT FLASH: .015 [.38].
 - MINIMUM PUSHOUT FORCE: 2 LB.
 - COPLANARITY TO INCLUDE INSULATOR.
 - ALL FIRST ROW PINS TO BE .001 [.025] BELOW TO .003 [0.076] ABOVE BODY(SEE DETAIL 'F').
 - SHEAR TO DIMENSION SHOWN.
 - MEASURE AT BEND.
 - T-1S13-XX-T-2 MUST BE FILLED IN THE SAME WAY AS THE SELECTIVE PLATED PINS TO PREVENT BAND MARKS FROM BEING IN THE POST AREA.
 - NOTE DELETED.
 - ALL SECOND ROW PINS TO BE .003[0.076] BELOW TO .003[0.076] ABOVE BODY (SEE DETAIL 'E').
 - TUBES ARE STANDARD PACKAGING.
 - ORDERS WILL BE PACKAGED ACCORDING TO THE SAMTEC PACKAGING EFFICIENCY STANDARDS (SPES) FOUND ON WWW.SAMTEC.COM.
 - ATTACH LABEL TO EACH REEL.

CPC
THIS SHEET

C1, C2, C7,
C10

UNLESS OTHERWISE SPECIFIED,
DIMENSIONS ARE IN INCHES.
TOLERANCES ARE:
DECIMALS ANGLES
.XX: ±.01 [.3] 2°
.XXX: ±.005 [.13]
.XXXX: ±.0020 [.051]

MATERIAL:
INSULATOR: LCP, UL 94 VO
TERMINAL: PHOSPHOR BRONZE

PROPRIETARY NOTE
THIS DOCUMENT CONTAINS CONFIDENTIAL AND PROPRIETARY INFORMATION AND ALL DESIGN, MANUFACTURING, REPRODUCTION, USE, PATENT RIGHTS AND SALES RIGHTS ARE EXPRESSLY RESERVED BY SAMTEC, INC. THIS DOCUMENT SHALL NOT BE DISCLOSED, IN WHOLE OR PART, TO ANY UNAUTHORIZED PERSON OR ENTITY NOR REPRODUCED, TRANSFERRED OR INCORPORATED IN ANY OTHER PROJECT IN ANY MANNER WITHOUT THE EXPRESS WRITTEN CONSENT OF SAMTEC, INC.

DO NOT SCALE DRAWING SHEET SCALE: 2.5:1

520 PARK EAST BLVD, NEW ALBANY, IN 47150
PHONE: 812-944-6733 FAX: 812-948-5047
e-Mail: info@SAMTEC.com code: 55322

DESCRIPTION:
2mm HORIZONTAL MOUNT TERMINAL STRIP ASSEMBLY

DWG. NO.
TSH-1XX-XX-XX-XX-XX-X-XX

BY: KEVIN B 9/8/99 SHEET 1 OF 3

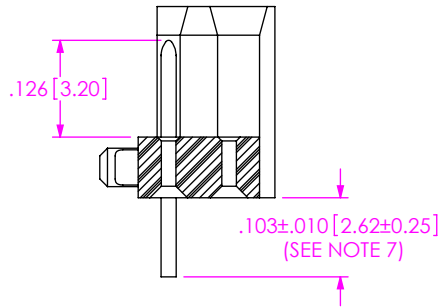

IN-PROCESS 1

POSITIONS -15 THRU -30

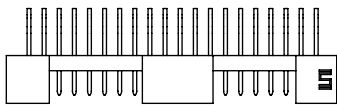

POSITIONS -31 THRU -48

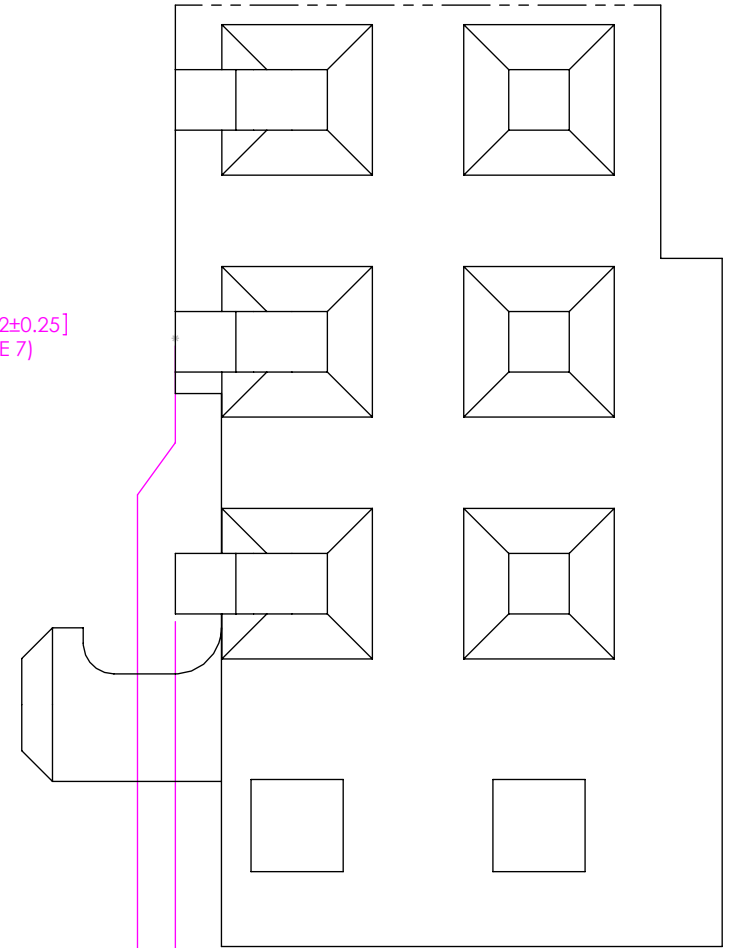
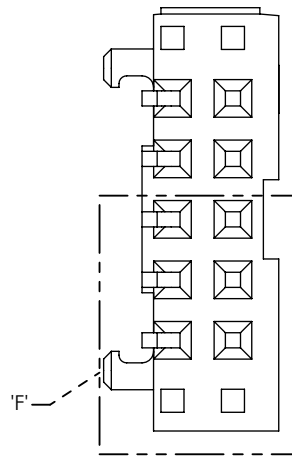
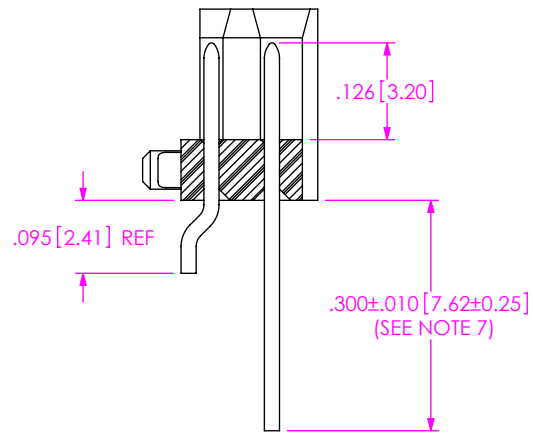
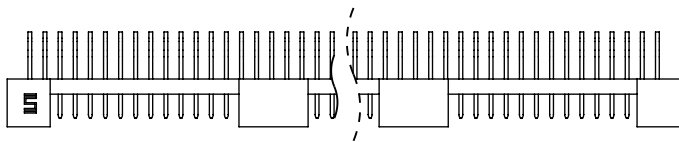

IN-PROCESS 2

F:\DWG\MISC\MKTG\TSH-1XX-XX-XX-XX-X-XX-MKT.SLDDRW

CPC
THIS SHEET

C3, C4, C11

PROPRIETARY NOTE
 * THIS DOCUMENT CONTAINS CONFIDENTIAL AND PROPRIETARY INFORMATION AND ALL DESIGN, MANUFACTURING, REPRODUCTION, USE, PATENT RIGHTS AND SALES RIGHTS ARE EXPRESSLY RESERVED BY SAMTEC, INC. THIS DOCUMENT SHALL NOT BE DISCLOSED, IN WHOLE OR PART, TO ANY UNAUTHORIZED PERSON OR ENTITY NOR REPRODUCED, TRANSFERRED OR INCORPORATED IN ANY OTHER PROJECT IN ANY MANNER WITHOUT THE EXPRESS WRITTEN CONSENT OF SAMTEC, INC.

DO NOT SCALE DRAWING

SHEET SCALE: 4:1



520 PARK EAST BLVD, NEW ALBANY, IN 47150
 PHONE: 812-944-6733 FAX: 812-948-5047
 e-Mail: info@SAMTEC.com code: 55322

DESCRIPTION:
 2mm HORIZONTAL MOUNT TERMINAL STRIP ASSEMBLY

DWG. NO.
TSH-1XX-XX-XX-XX-XX-X-XX

BY: KEVIN B 9/8/99 SHEET 2 OF 3

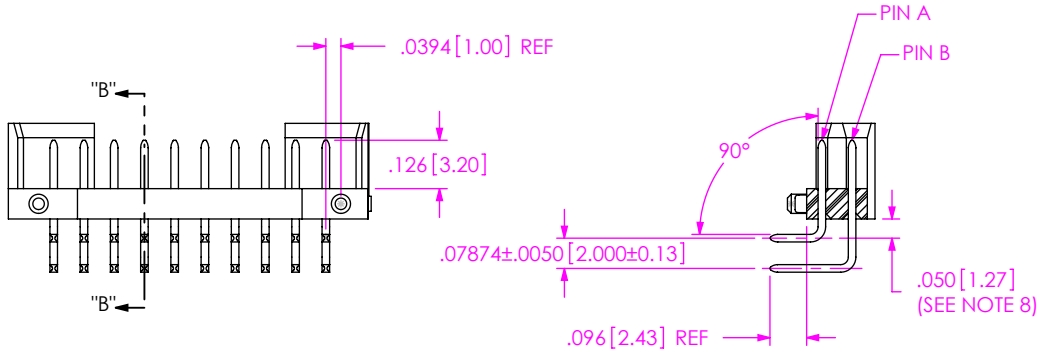
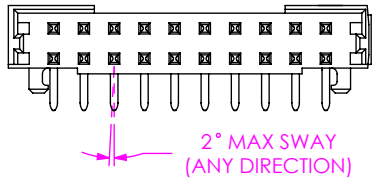

FIG 2
-RA: RIGHT ANGLE
(SAME AS FIG 1, UNLESS OTHERWISE STATED)
[AVAILABLE IN POSITIONS -05 THRU -48]

SECTION "B"-"B"

"R" = USE MEASURED DIMENSION
"S" = (("R" - .177[4.50]) / 2) ± .020[.51]

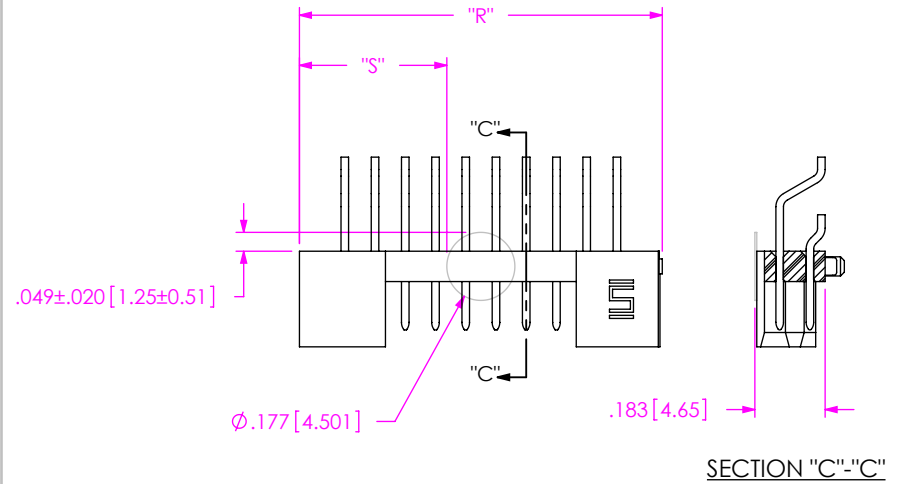
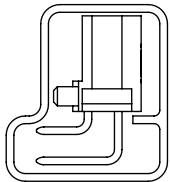

FIG 3

-K: POLYIMIDE FILM PAD
(10 POSITION MIN)
(SAME AS FIG 1, UNLESS OTHERWISE STATED)

NOTE:
FOR 15 THRU 30 POSITIONS, -K OPTION NOT NEEDED DUE TO LOCATION OF PLASTIC SHROUD

PACKAGING VIEW
-RA OPTION



TUBE: PT-1-24-01-45
PLUG: TP-03

PACKAGING VIEW
-DH OPTION

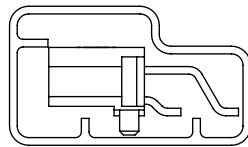

TUBE: PT-1-24-05-17
PLUG: TP-07

NOTE:
ALL POSITIONS ARE TO BE TUBED.

CRITICAL DIMENSION INSPECTION INSTRUCTION TABLE	
ASSEMBLY OPERATION	IN-PROCESS INSPECTION
FILL T-1S13-09-XX-2 (DH)	C1
FORM T-1S13-09-XX-2 (DH)	C2, C3, C4, C7, C10, C11
FILL T-1S13-XX-XX-2 (RA)	C1
RA T-1S13-XX-XX-2	C5, C6
CPS's INTENTIONALLY DELETED	C8, C9

CPC
THIS SHEET

C1, C5, C6

PROPRIETARY NOTE
THIS DOCUMENT CONTAINS CONFIDENTIAL AND PROPRIETARY INFORMATION AND ALL DESIGN, MANUFACTURING, REPRODUCTION, USE, PATENT RIGHTS AND SALES RIGHTS ARE EXPRESSLY RESERVED BY SAMTEC, INC. THIS DOCUMENT SHALL NOT BE DISCLOSED, IN WHOLE OR IN PART, TO ANY UNAUTHORIZED PERSON OR ENTITY FOR REPRODUCTION, TRANSFERRED OR INCORPORATED IN ANY OTHER PROJECT IN ANY MANNER WITHOUT THE EXPRESS WRITTEN CONSENT OF SAMTEC, INC.

DO NOT SCALE DRAWING

SHEET SCALE: 2:1



520 PARK EAST BLVD, NEW ALBANY, IN 47150
PHONE: 812-944-6733 FAX: 812-948-5047
e-Mail: info@SAMTEC.com code: 55322

DESCRIPTION:
2mm HORIZONTAL MOUNT TERMINAL STRIP ASSEMBLY

DWG. NO.
TSH-1 XX-XX-XX-XX-XX-X-XX

BY: KEVIN B 9/8/99 SHEET 3 OF 3