

## Simple Fast Charger Controller

### Product Features

- Fast charge of nickel cadmium (NiCd) or nickel-metal hydride (NiMH) batteries
- Fast-charge termination by negative delta voltage, maximum voltage, maximum temperature, and 90 minutes charging time
- Support 1 to 8 cells fast charging
- 10% (PT8A2704) or 4% (PT8A2704A) of constant charging current for trickle charging
- On-chip 2.0V regulator
- On chip precise ADC
- Internal RC oscillator with external R&C components
- Low cost 8-pin DIP/SOIC package

### Applications

- Rechargeable shavers and hair cutters
- Rechargeable RC cars
- Rechargeable power tools

### Product Description

The PT8A2704/04A Fast-Charger IC is low-cost CMOS battery-charge controller providing reliable charge termination for both NiCd and NiMH battery applications, such as Power tool and Consumer electronics. A current-limited or constant-current supply allows the PT8A2704/04A to be a cost-effective charger with only a few external components. The PT8A2704/04A has programmable charging time and programmable trickle charging rate control by options in a single IC for charging NiCd or NiMH battery cells.

For safety, fast or trickle charging is inhibited if the battery temperature is over a safety threshold. Fast charge is terminated by any of the following:

- Negative delta voltage/zero delta voltage
- Maximum voltage
- Maximum temperature
- Maximum time

### Pin Assignment and Pin Description

PT8A2704/04A  
DIP-8 or SOIC-8  
Package (Top View)

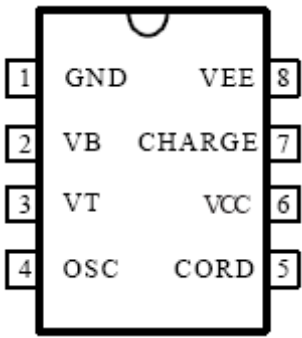

**Pin Description**

Pin No.	Pin Name	I/O	Description
1	GND	-	Power ground
2	VB	I	Battery voltage input (1.6V – 1.8V)
3	VT	I	NTC voltage input(1.6V – 1.8V)
4	OSC	I	RC oscillator input, external resistor pull-up and capacitor pull-down
5	CORD	I	Cord detection input
6	VCC	-	Positive power supply voltage
7	CHARGE	O	Charging control enable
8	VEE	O	2.0v regulated voltage

## Block Diagram

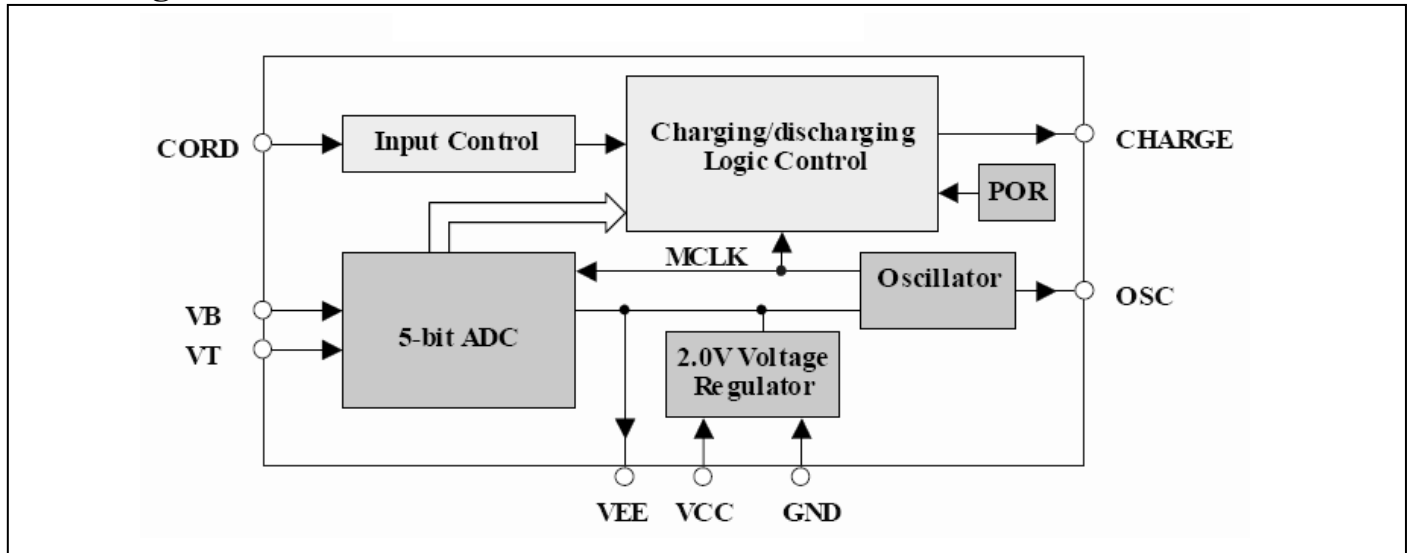

## Functional Description

**Voltage Regulator (2.0V Regulator):** Build-in voltage regulator used to power supply RC oscillator, precise ADC.

**Oscillator:** Internal RC oscillator to generate a 64 kHz clock for internal system.

**POR (Power-on Reset):** Power on reset to reset all internal logic while power on.

**Charging Control:** Charging control enables output CHARGE pin which can be used to show charging status. It is logic high during constant current charging and 12.5Hz with 10% (for PT8A2704) or 4% (for PT8A2704A) duty cycle during trickle current charging

**AC Cord Control:** CORD input is external cord detection pin (digital level), active high.

**Precision ADC:**

**VB** measures the battery voltage. VB is a divide voltage from the battery voltage. When VB exceeds the maximum voltage (0.9VEE), fast charging will be terminated. Moreover, VB detects the negative delta voltage during fast charging. It is suggested to set the termination voltage of VB within the input range of the ADC which is 0.8VEE to 0.9VEE.

**VT** measures the temperature of the battery with an external NTC (refer to *How to determine RX1 on page5*). Maximum temperature termination occurs when the VT exceeds a temperature cut-off threshold voltage (eg. 50°C which equivalent to 0.887VEE). Constant current or trickle charging will stop completely when the temperature exceeds another threshold voltage (eg. 55°C which equivalent to 0.897VEE).

### Charging Cycle Phases

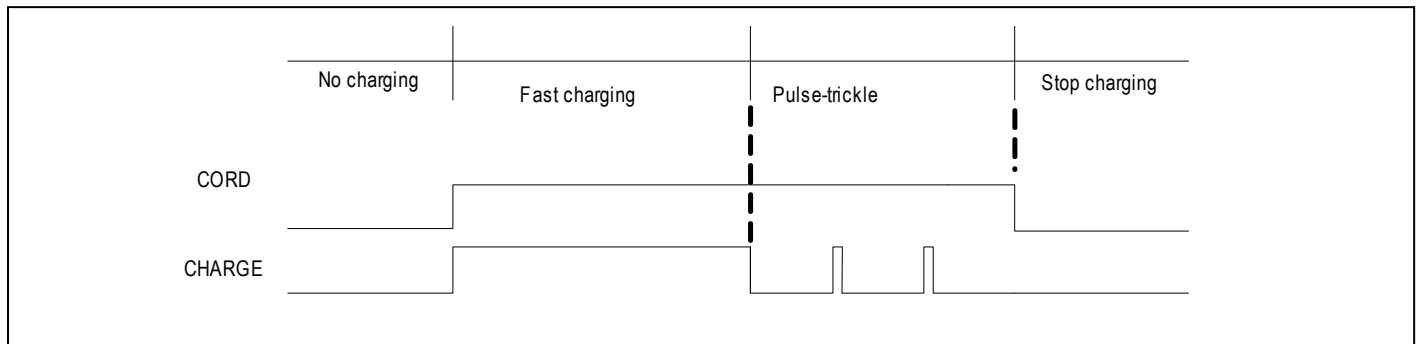

Fast charge is started when the CORD is high. If the battery voltage is over the limit or temperature exceeds 50°C, pulse-trickle charge begins and the device charges the battery with trickle charge till the CORD is low (see above Figure).

Fast charge will be termination by one or more of the four possible termination conditions:

- negative delta voltage/delta voltage
- maximum voltage
- maximum temperature
- maximum time

## Maximum Ratings

Storage Temperature.....	-25°C to +85°C
Supply Voltage to Ground Potential (V <sub>CC</sub> ).....	-0.5V to 6V
DC Input Voltage.....	-0.5V to V <sub>CC</sub> +0.5V
DC Output Current.....	20mA
Power Dissipation.....	500mW

**Note:**

Stresses greater than those listed under MAXIMUM RATINGS may cause permanent damage to the device. This is a stress rating only and functional operation of the device at these or any other conditions above those indicated in the operational sections of this specification is not implied. Exposure to absolute maximum rating conditions for extended periods may affect reliability.

## Recommended Operation Condition

Parameters	Description	Min.	Typ.	Max.	Unit
V <sub>CC</sub>	Operating Voltage	2.2	2.4	5.5	V
ADC V <sub>IN</sub>	Input voltage range (VT, VB)	0.8	-	0.9	VEE
Fosc	Frequency of oscillator (C=390pF, R=47kΩohm)	54.4	64	73.6	kHz
T <sub>A</sub>	Operation Temperature	0	25	70	°C

## DC Electrical Characteristics

(T<sub>A</sub>= 0~70°C, V<sub>CC</sub>= 2.4V unless otherwise claims)

Symbol	Description	Test Conditions	Min.	Typ.	Max.	Unit
I <sub>IL</sub> , I <sub>IH</sub>	Input Low/HIGH leakage current for CORD pin	V <sub>CC</sub> =2.4V, V <sub>IL</sub> =0.2V, V <sub>IH</sub> =2.2V	-1	-	1	μA
I <sub>OH</sub>	Output HIGH current	CHARGE pin, V <sub>OH</sub> =2.2V	-3	-	-	mA
I <sub>OL</sub>	Output LOW current	CHARGE pin, V <sub>OL</sub> =0.2V	3	-	1	
VEE	Regulator output voltage	No load	1.9	2.0	2.1	V
ΔV <sub>O</sub>	Line Regulation of regulator	2.2V ≤ V <sub>CC</sub> ≤ 3.0V, No load	-	-	50	mV
ΔV <sub>LDR</sub>	Load regulation	0mA ≤ I <sub>L</sub> ≤ 3mA	-	-	50	mV
VB <sub>max</sub>	Maximum battery voltage to stop fast-charge	-	-	0.9	-	VEE
VT <sub>max</sub>	Maximum VT voltage for battery temperature detection to stop fast-charge	-	-	0.897	-	VEE
R <sub>sIt</sub>	Average A/D resolution of ADC	No load	6.00	6.25	6.50	mV
DNL	ADC Differential nonlinearity	No load	-	1	-	LSB
INL	ADC Integral nonlinearity	No load	-	1	-	LSB
I <sub>CC</sub>	Supply Current	R=47kΩ, C=390pF, no load	-	-	380	μA

## AC Electrical Characteristics

(T<sub>A</sub>= 0~70°C, V<sub>CC</sub>= 2.2V~3.0V)

Symbol	Description	Test Conditions	Min.	Typ.	Max.	Unit
F <sub>OSC</sub>	Oscillator Frequency	C=390pF, R=47kΩ	54.4	64	73.6	kHz
T <sub>FC</sub>	Maximum fast-charge time	OSC=64kHz	-	90	-	Minutes
DC	Duty-cycle of charge pin output in trickle charge mode	PT8A2704	7	10	13	%
		PT8A2704A	3	4	5	%

### Typical Application Circuit

#### 1. Application circuit for larger discharging current.

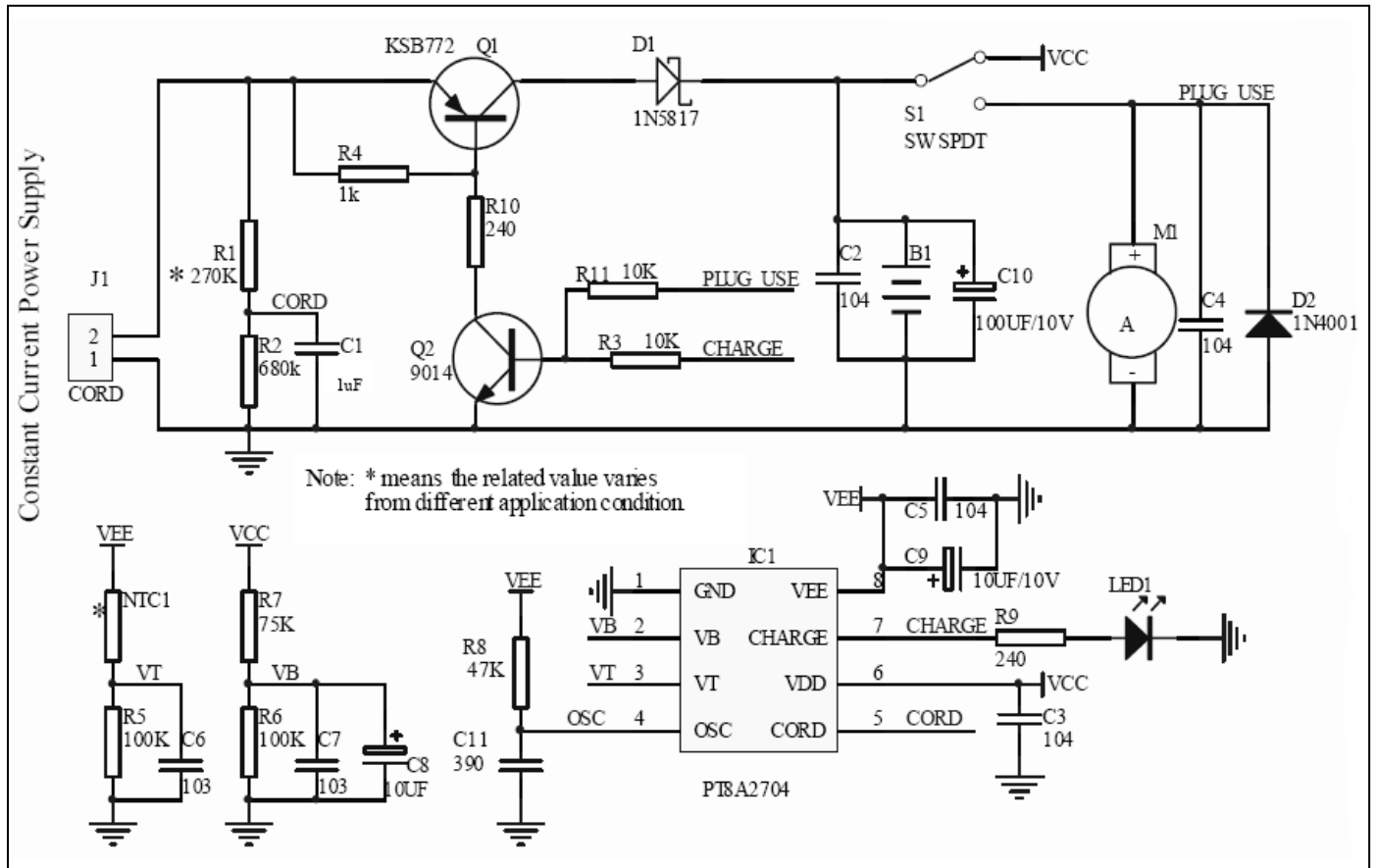

#### PT8A2704/04A Application Circuit for Shaver with Two Batteries

Note:

- R1 value can be adjusted to make sure the CORD voltage is around 2.0V.
- As the device is always powered by battery, the static consumption must be considered in application design.

### 2. Application circuit for smaller discharging current.

If discharging current is smaller, suggest using the following schematic:

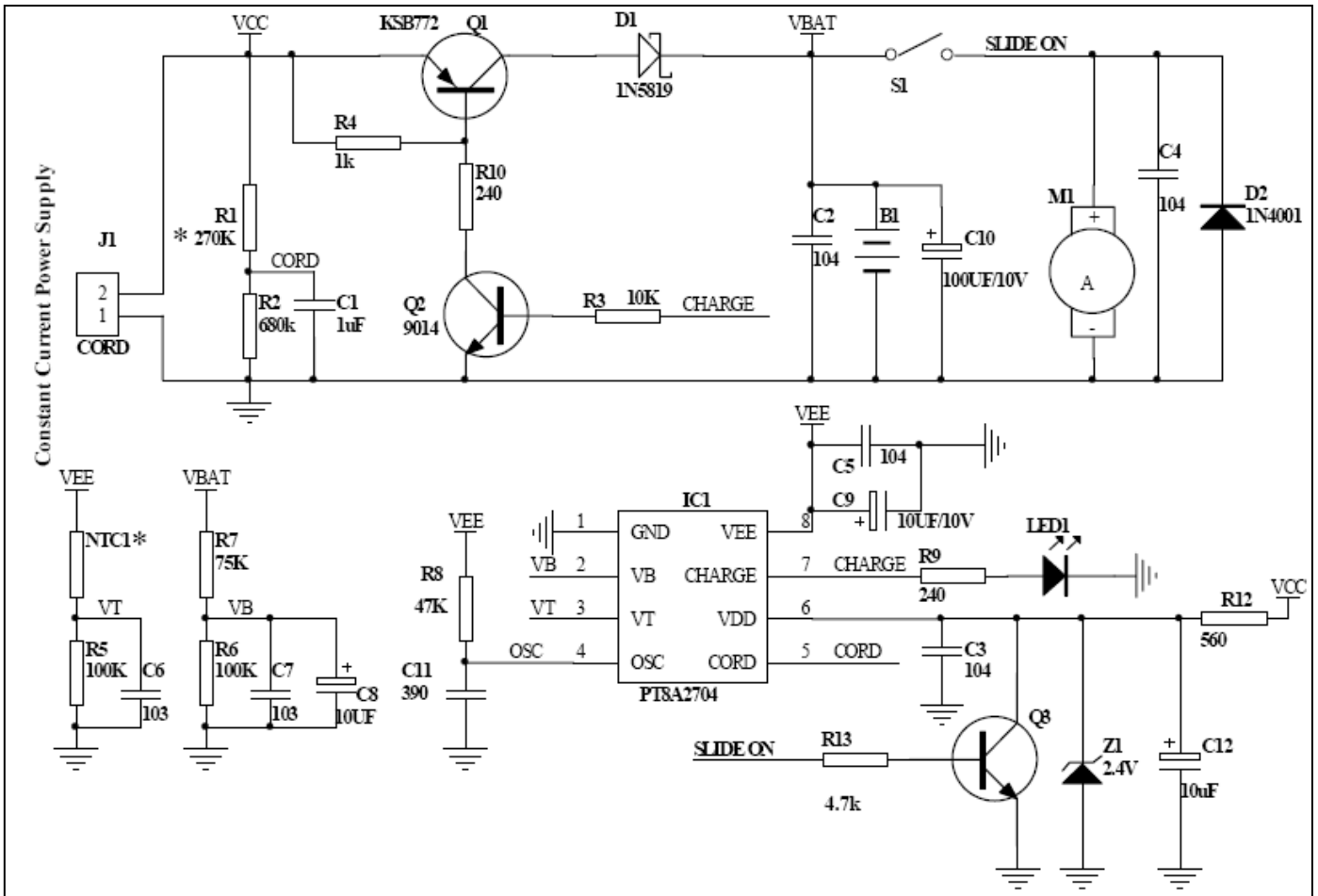

**PT8A2704/04A Application Circuit for Shaver with Two Batteries**

### PCB Layout Constraint

1. Cross angle between two Tracks should be larger than 90 degree.
2. Track should be short and wide enough to reduce voltage drop, especially Power supply and Ground as well as some tracks flowing with large current, such as switch Q1.
3. A ceramic cap C6 about 103 need to add between VT and Ground of PT8A2704 in order to prevent detection circuit from noise.
4. A ceramic cap C7 about 103 and C8 10µF Tan cap need to add between VB to Ground.

### How to determine RX1

Assuming Resistance of NTC at 55°C is RT.  
 See right figure, below formula can be attained.  
 $VT = RX1 * VEE / (RX1 + RT) = 1.8V$   
 VEE = 2.0V, finally  
 $RX1 = 9 * RT$

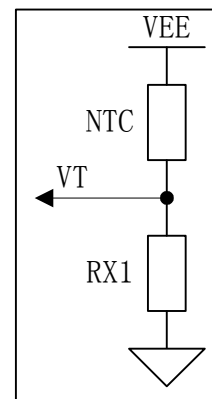

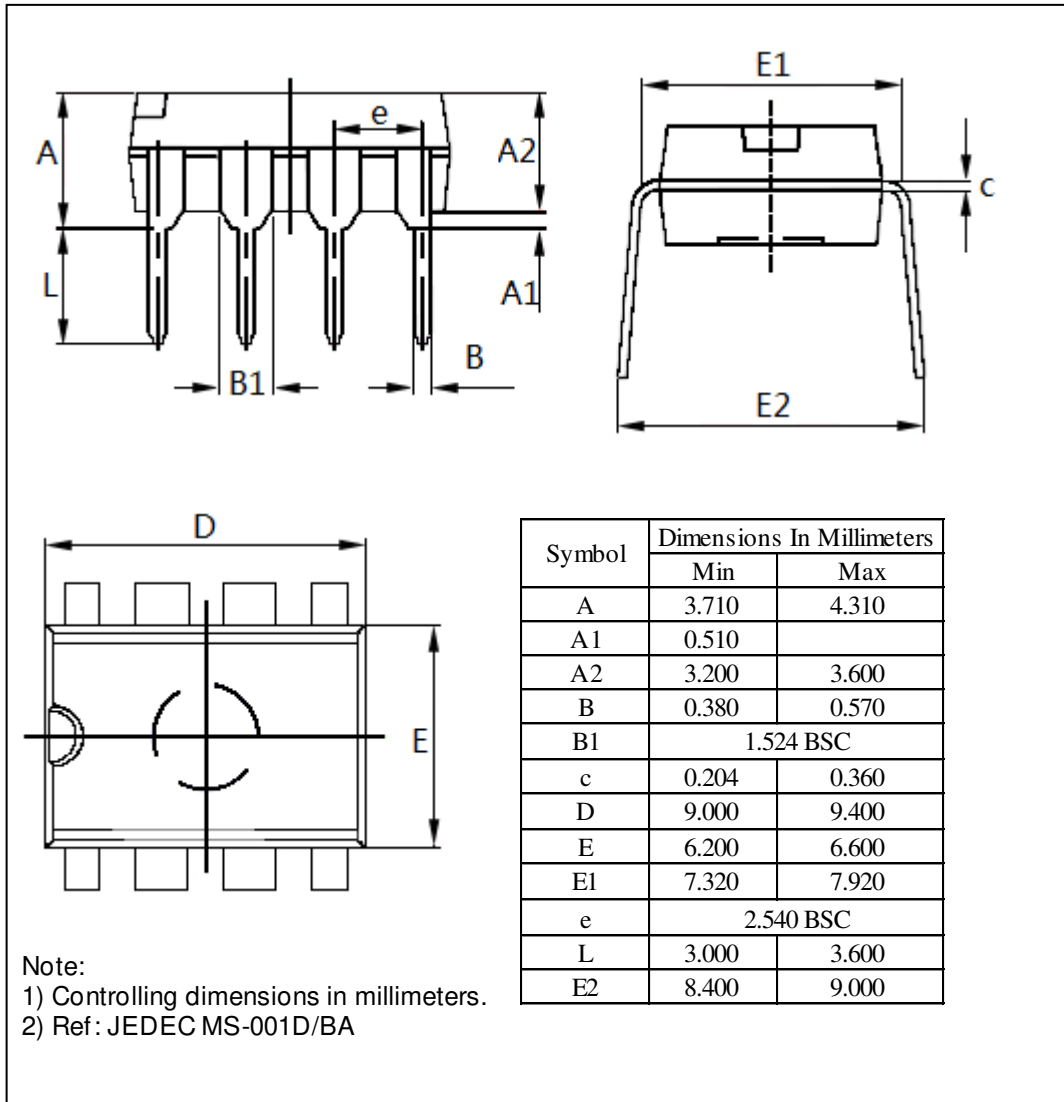
**Mechanical Information**
**8-Pin DIP**

WE (8-Pin SOIC)

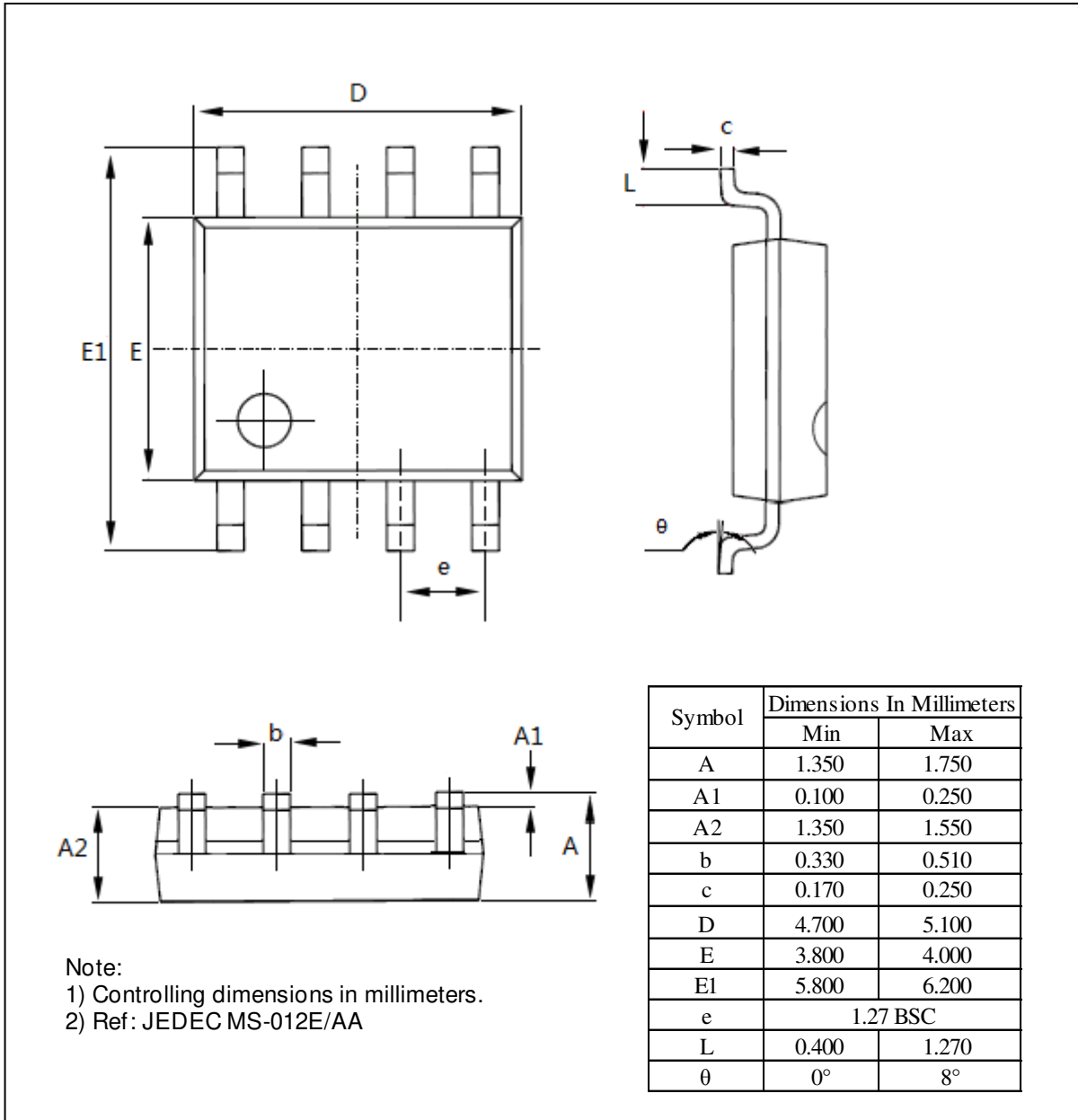

## Ordering Information

Part Number	Package Code	Package
PT8A2704PE	P	Lead free 8-Pin DIP
PT8A2704WE	W	Lead free and Green 8-Pin SOIC
PT8A2704APE*	P	Lead free 8-Pin DIP
PT8A2704AWE*	W	Lead free and Green 8-Pin SOIC

### Notes:

- E = Pb-free or Pb-free and Green
- Adding X Suffix= Tape/Reel
- \*Contact Pericom for availability.

Pericom Semiconductor Corporation • 1-800-435-2336 • [www.pericom.com](http://www.pericom.com)

Pericom reserves the right to make changes to its products or specifications at any time, without notice, in order to improve design or performance and to supply the best possible product. Pericom does not assume any responsibility for use of any circuitry described other than the circuitry embodied in Pericom product. The company makes no representations that circuitry described herein is free from patent infringement or other rights, of Pericom.