

MOLEX IRELAND PRODUCTION ONLY (OPTION)

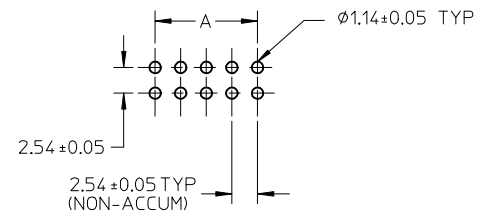
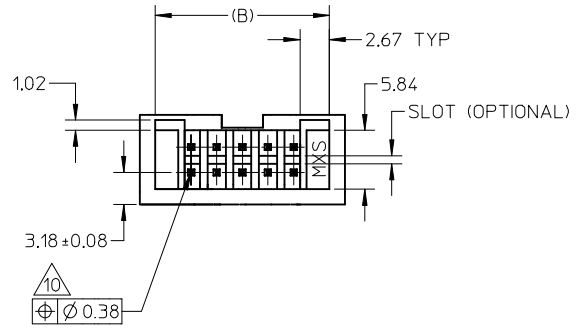

RECOMMENDED PCB HOLE LAYOUT

NOTES:

1. PIN PUSHOUT FORCE (.9072KG)/2LBS MIN.
2. PIN SOLDERABILITY PER MOLEX SPEC. ES-152.
3. PRODUCT SPEC: PS-70246-100 APPLIES.
4. WAFER TO BE FLAT WITHIN .003 MM/MM.
5. DIMENSIONS FOR PLATING LOCATION:
 - 5A MEASURE POINT FOR THICKNESS
 - 5B MINIMUM COVERAGE
6. GOLD END OF PIN UNLESS OVERALL PLATED.
7. FINISH:
 - 571 : 15 MICRO INCHES MIN GOLD PLATE ON CONTACT AND 75 MICRO INCHES MIN TIN PLATE ON SOLDER TAIL BOTH OVER 50 MICRO INCHES MIN NICKEL OVERALL.
 - 574 : 30 MICRO INCHES MIN GOLD PLATE ON CONTACT AND 75 MICRO INCHES MIN TIN PLATE ON SOLDER TAIL BOTH OVER 50 MICRO INCHES MIN NICKEL OVERALL.
 - 544 : 5 MICRO INCHES MIN GOLD PLATE ON CONTACT AND 75 MICRO INCHES MIN TIN PLATE ON SOLDER TAIL BOTH OVER 50 MICRO INCHES MIN NICKEL OVERALL.
 - 573 : 20 MICRO INCHES MIN GOLD PLATE ON CONTACT AND 100 MICRO INCHES MIN TIN PLATE ON SOLDER TAIL BOTH OVER 50 MICRO INCHES MIN NICKEL OVERALL.
8. DIM AT THE CENTRE OF THE SHROUDED WALL SHALL BE 5.91MM MIN. THIS SPEC IS VALID FOR ALL CKT SIZE.
9. MATERIAL:
 - HSG: GLASS FILLED PBT, UL94V-0, COLOUR BLACK
 - PIN: 0.64MM SQ. PIN PHOSPHOR BRONZE.
10. SOLDER TAIL POSITIONAL TOLERANCE SHALL BE GAUGED.

UPDATE NOTE #3. EC NO: S2013-0029 DRW:ATSEE 2012/07/20 CHKD:SKANG 2012/08/06 APPR:MLONG 2012/10/08	QUALITY SYMBOLS ▽=0 ◻=0	GENERAL TOLERANCES (UNLESS SPECIFIED)		DIMENSION STYLE MM ONLY		SCALE NTS	DESIGN UNITS METRIC	THIRD ANGLE PROJECTION		
			mm	INCH	DRAWN BY	DATE	TITLE			
		4 PLACES	± ---	± ---	JENNIFER	1987/09/18	C-GRID, SHROUDED HEADER (SLOTTED W/O STANDOFFS)			
		3 PLACES	± ---	± ---	CHECKED BY	DATE				
2 PLACES	± 0.20	± ---	RWONG	1987/09/18	MOLEX INCORPORATED					
1 PLACE	± ---	± ---	APPROVED BY	DATE						
	ANGULAR ± 3 °		ALANB	1987/09/18	MATERIAL NO. SEE TABLE		DOCUMENT NO. SDA-70246-**20-25_39-41		SHEET NO. 1 OF 2	
DRAFT WHERE APPLICABLE MUST REMAIN WITHIN DIMENSIONS		SIZE A3		THIS DRAWING CONTAINS INFORMATION THAT IS PROPRIETARY TO MOLEX INCORPORATED AND SHOULD NOT BE USED WITHOUT WRITTEN PERMISSION						

10	9		8		7		6	5	4	3	2	1
PART NUMBER	CKT SIZE	VOID CKT	DIM A	DIM B	DIM C	DIM D	VOID CKT, ONLY APPLY TO PLATING CODE					
70246-08**	08	-	7.62	14.73	17.78	15.24	-					
70246-10**	10	-	10.16	17.27	20.32	17.78	-					
70246-12**	12	-	12.70	19.81	22.86	20.32	-					
70246-14**	14	-	15.24	22.35	25.40	22.86	-					
70246-16**	16	-	17.78	24.89	27.94	25.40	-					
70246-20**	20	-	22.86	29.97	33.02	30.48	-					
70246-24**	24	-	27.94	35.05	38.10	35.56	-					
70246-26**	26	-	30.48	37.59	40.64	38.10	-					
70246-30**	30	-	35.56	42.67	45.72	43.18	-					
70246-34**	34	-	40.64	47.75	50.80	48.26	-					
70246-40**	40	-	48.26	55.37	58.42	55.88	-					
70246-44**	44	-	53.34	60.45	63.50	60.96	-					
70246-50**	50	-	60.96	68.07	71.12	68.58	-					
70246-1003	10	10	10.16	17.27	20.32	17.78	571					

LEGEND:

70246 - * * * * *

CKT SIZE

PLATING OPT.

SEE TABLE FOR DETAIL



△ PART NUMBER	PLATING OPTION
70246-**-01	571
70246-**-02	574
70246-**-04	544

D

C

B

A

UPDATE NOTE #3. EC NO: S2013-0029 2012/07/20 DR:WATSEE 2012/08/06 CHK:SKANG 2012/10/08 APPR:MLONG	QUALITY SYMBOLS  = 0  = 0.20	GENERAL TOLERANCES (UNLESS SPECIFIED)		DIMENSION STYLE MM ONLY		SCALE NTS	DESIGN UNITS METRIC	 THIRD ANGLE PROJECTION	
		4 PLACES ± --- ± ---	DRAWN BY JENNIFER	DATE 1987/09/18	TITLE C-GRID, SHROUDED HEADER (SLOTTED W/O STANDOFFS)				
		3 PLACES ± --- ± ---	CHECKED BY RWONG	DATE 1987/09/18					
		2 PLACES ± 0.20 ± ---	APPROVED BY ALANB	DATE 1987/09/18					
1 PLACE ± --- ± ---	MATERIAL NO. SEE TABLE								
DRAFT WHERE APPLICABLE MUST REMAIN WITHIN DIMENSIONS		ANGULAR ± 3 °		MOLEX INCORPORATED		DOCUMENT NO. SDA-70246-**-20-25_39-41	SHEET NO. 2 OF 2		
SIZE A3		THIS DRAWING CONTAINS INFORMATION THAT IS PROPRIETARY TO MOLEX INCORPORATED AND SHOULD NOT BE USED WITHOUT WRITTEN PERMISSION							