

PART NUMBER	ENGINEERING NO.	LENGTH
1300390095	DN5210A-M005	1' 7.68" +1.75 - 0 [0.5M +44.5 - 0]
1300390096	DN5210A-M010	3' 3.00" +2.19 - 0 [1.0M +55.6 - 0]
1300390097	DN5210A-M020	6' 6.72" +3.50 - 0 [2.0M +88.9 - 0]

- NOTES:
1. MATERIAL: SEE TABLE
 2. FINISHES: SEE TABLE
 3. CABLE ASSEMBLIES ARE BAGGED SEPARATELY IN POLY BAGS WITH BARCODE LABEL ATTACHED TO OUTSIDE OF BAG
 4. WRAP LABEL IS MARKED WITH P/N, DATE CODE VOLTAGE & AMPERAGE
 5. MATES WITH: MINI CHANGE, A-SIZE 5 POLE RECEPTACLE & CORD ASSEMBLY
 6. ELECTRICAL SPECIFICATIONS:
VOLTAGE RATING: 300V
CURRENT RATING: 4 AMPS
 7. ASSEMBLY IS RoHS COMPLIANT

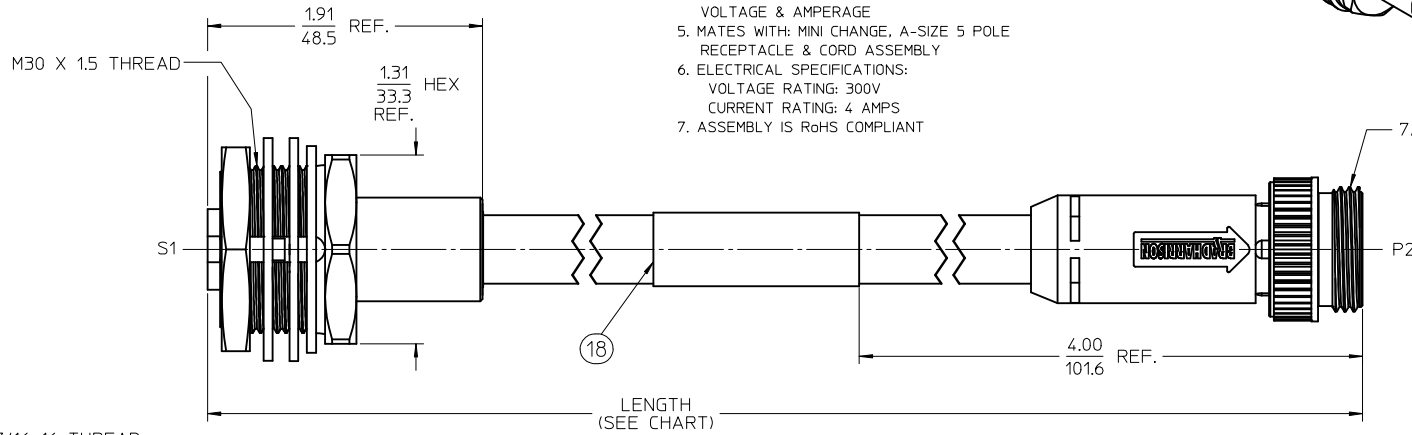

7/16-16 THREAD

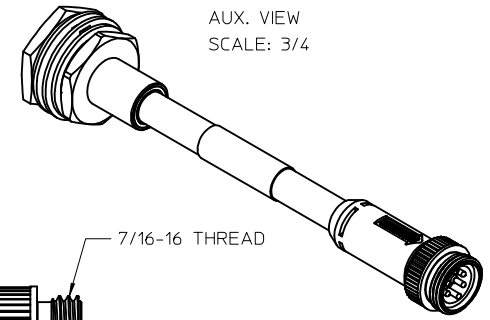
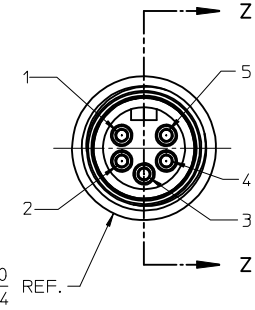
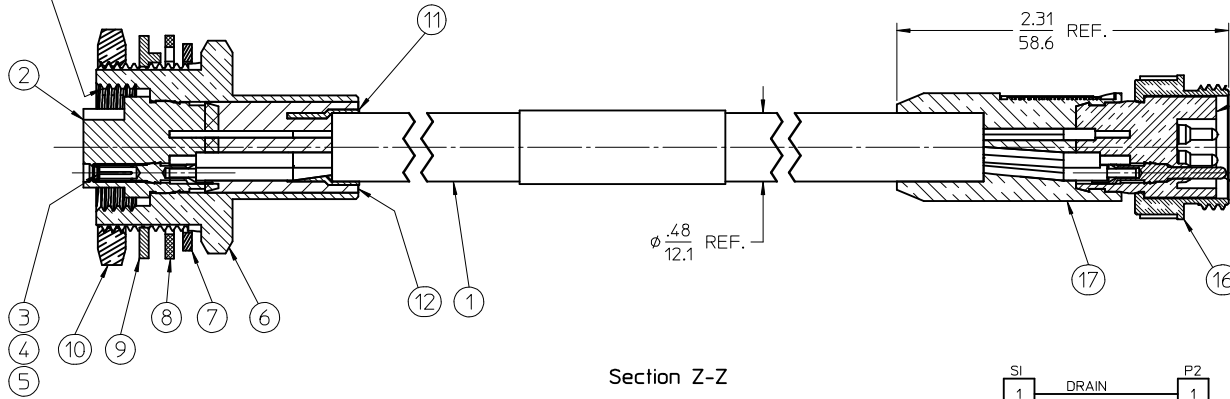
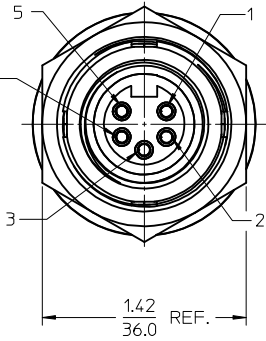

Section Z-Z

SI		P2
1	DRAIN	1
2	RED +V	2
3	BLACK -V	3
4	WHITE CAN H	4
5	BLUE CAN L	5

WIRING DIAGRAM

ITEM	QTY.	DESCRIPTION	MATERIAL	FINISH
18	1	LABEL	PLASTIC FILM	BLACK/YELLOW
17	1	OVERMOLD	PVC	GRAY
16	1	COUPLING NUT, MALE	ZINC DIE CAST	BLACK
15	3	CONTACT PIN, 18 AWG	BRASS	GOLD PLATED
14	2	CONTACT PIN, 16 AWG	BRASS	GOLD PLATED
13	1	INSERT, MALE, 5 POLE	PVC	GRAY
12	1	POTTING	EPOXY	BLACK
11	1	SHRINK TUBE	POLYOLEFIN	
10	1	HEXNUT	BRASS	NICKEL PLATED
9	1	THRUST WASHER	ZINC	NICKEL PLATED
8	1	FLAT WASHER	NYLON	WHITE
7	1	GASKET	NITRILE	BLACK
6	1	RECEPTACLE SHELL	BRASS	NICKEL PLATED
5	5	SOCKET SLEEVE	ST. STEEL	
4	3	CONTACT SOCKET, 18 AWG	BRASS	GOLD PLATED
3	2	CONTACT SOCKET, 16 AWG	BRASS	GOLD PLATED
2	1	INSERT, FEMALE, 5 POLE	PVC	GRAY
1	1	CABLE, DEV-NET, TRUNK, 18/2, 15/2	PVC JACKET	GRAY

RELEASED EC NO: MNA2009-0778 DRAWN BY: DRWINRSTONE 2009/05/29 CHKD BY: WOODMAN APPR: J.MURPHY 2009/06/10	QUALITY SYMBOLS ▽=0 ▽=0	GENERAL TOLERANCES (UNLESS SPECIFIED) <table border="1"> <thead> <tr> <th></th> <th>mm</th> <th>INCH</th> </tr> </thead> <tbody> <tr> <td>4 PLACES ±</td> <td>--- ±</td> <td>---</td> </tr> <tr> <td>3 PLACES ±</td> <td>---</td> <td>---</td> </tr> <tr> <td>2 PLACES ±</td> <td>---</td> <td>±.01</td> </tr> <tr> <td>1 PLACE ±</td> <td>0.3 ±</td> <td>---</td> </tr> </tbody> </table>			mm	INCH	4 PLACES ±	--- ±	---	3 PLACES ±	---	---	2 PLACES ±	---	±.01	1 PLACE ±	0.3 ±	---	DIMENSION STYLE IN/MM	SCALE 1.5:1	DESIGN UNITS INCH	THIRD ANGLE PROJECTION
			mm	INCH																		
		4 PLACES ±	--- ±	---																		
3 PLACES ±	---	---																				
2 PLACES ±	---	±.01																				
1 PLACE ±	0.3 ±	---																				
DRAFT WHERE APPLICABLE MUST REMAIN WITHIN DIMENSIONS		DRAWN BY R.STONE	DATE 2009/05/27	TITLE MINI-CHANGE, CORD/RECEPT M/F STRAIGHT DEV-NET, TRUNK CABLE																		
MATERIAL NO. SEE CHART		CHECKED BY B.WOODMAN	DATE 2009/05/29	MOLEX INCORPORATED																		

APPROVED BY: J.MURPHY 2009/06/05

DOCUMENT NO. SD-130039-005

SHEET NO. 1 OF 1

THIS DRAWING CONTAINS INFORMATION THAT IS PROPRIETARY TO MOLEX INCORPORATED AND SHOULD NOT BE USED WITHOUT WRITTEN PERMISSION