

## 3-Channel LED Array Driver IC

### Features

- Integrated 200V, 25Ω (Typical) MOSFETs
- Programmable Output Current of up to 80 mA per Channel
- TTL-Compatible PWM Dimming Inputs
- Three-Phase Synchronous Operation
- Leading Edge Blanking
- Individual Channel Short-Circuit Protection with Skip Mode
- Overtemperature Protection

### Applications

- LCD Panel Backlighting
- DLP RPTV or Projector LED Engine Driver
- RGB Decorative Lighting
- General LED Lighting

### General Description

The HV9980 is a fully integrated 3-channel peak-current PWM controller for driving buck converters in Constant Output Current mode. It is optimized for use with a large array of 20 mA to 80 mA LED strings, where multiple HV9980 ICs are used, sharing a common clock and a common reference voltage.

Both the clock and the voltage reference are external to the HV9980 for improved output current accuracy and uniform illumination. The output currents are programmed by controlling peak source current in each of the three internal 200V, 25Ω switching MOSFETs.

The peak current is detected by monitoring voltage at external sense resistors connected to RSENSE1-3. The switching MOSFET is turned off when the corresponding current sense signal exceeds the reference voltage applied at REF1-3 (in the case of normal output signal polarity). The beginning of the next switching cycle is determined by the external clock signal received at the CLK input. All three channels operate at a switching frequency of 1/6 of the external clock frequency and positioned 120° out-of-phase for the purpose of input and output ripple current reduction. Each channel is protected from an output Short-circuit condition. When an Overcurrent condition is detected in the output switch (RSENSE1-3), the corresponding channel shuts down for 200 μs. The HV9980 recovers automatically, when the Short-circuit Overcurrent condition is removed. Each current sense input (CS1-CS3) is equipped with a leading edge blanking delay to prevent false triggering of the current sense comparators due to circuit parasitics.

Overtemperature protection is included to prevent destructive failures due to overheating. Programmable slope compensation is available at each CS input. AGND and PGND1-3 must be tied together on the printed circuit board (PCB). VDD1-3 must be also connected together on the PCB.

### Package Type

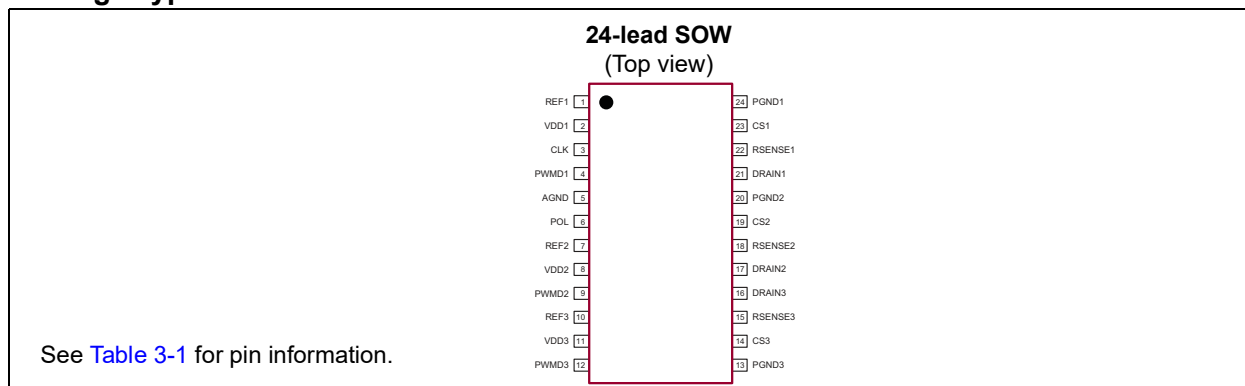

# HV9980

## Functional Block Diagram

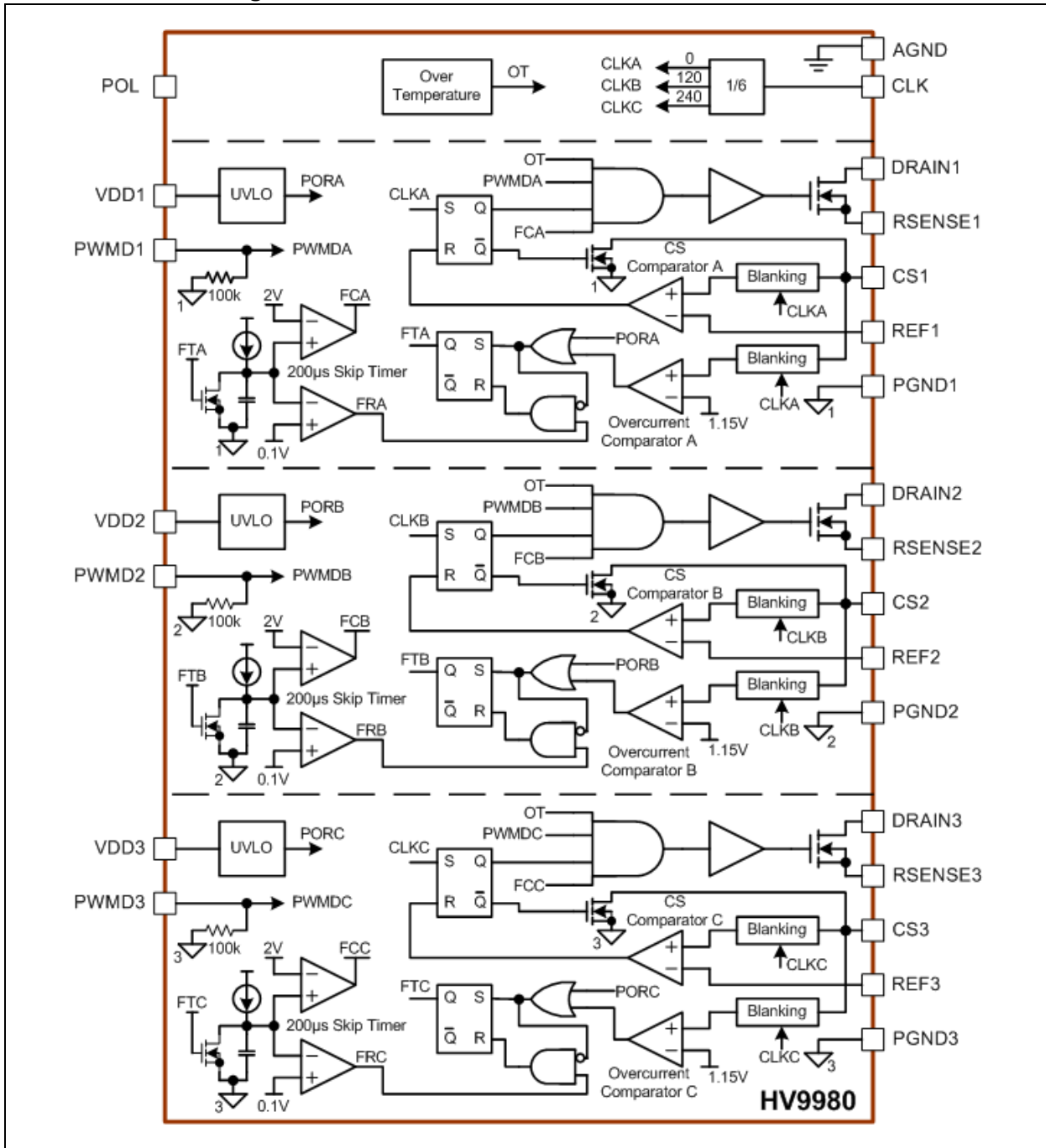

## Typical Application Circuit

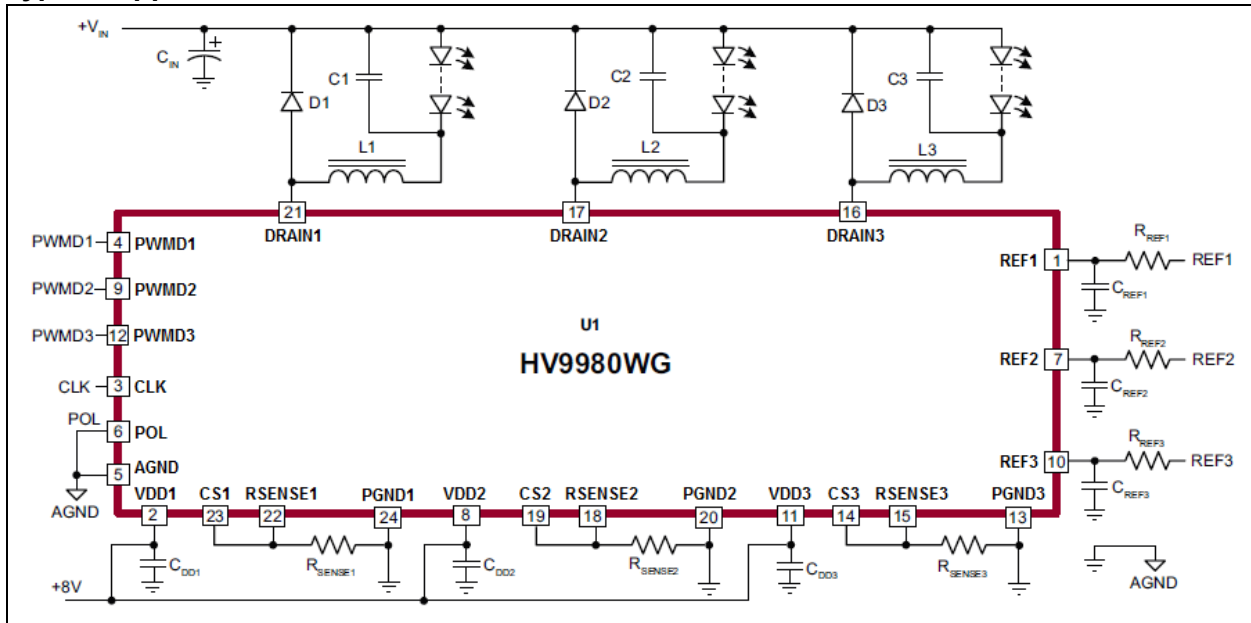

# HV9980

## 1.0 ELECTRICAL CHARACTERISTICS

### Absolute Maximum Ratings †

Supply Voltage, $V_{DD1-3}$ .....	-0.3V to +10V
DRAIN1–3 Outputs .....	-0.3V to +200V
CS1–3 Inputs .....	-0.3V to +5V
Other Inputs and Outputs .....	-0.3V to $V_{DD}$
Supply Current, $I_{DD}$ .....	+10 mA
Junction Temperature, $T_J$ ( <b>Note 1</b> ) .....	-40°C to +150°C
Storage Temperature Range, $T_S$ .....	-65°C to +150°C
Power Dissipation ( $T_A = +25^\circ\text{C}$ ) 24-lead SOW.....	1300 mW

† **Notice:** Stresses above those listed under “Absolute Maximum Ratings” may cause permanent damage to the device. This is a stress rating only, and functional operation of the device at those or any other conditions above those indicated in the operational sections of this specification is not intended. Exposure to maximum rating conditions for extended periods may affect device reliability.

**Note 1:** Operation out of this range will be destructive to the IC.

## ELECTRICAL CHARACTERISTICS

**Electrical Specifications:**  $T_A = 25^\circ\text{C}$  and  $V_{DD} = 8\text{V}$  unless otherwise specified.

Parameter	Sym.	Min.	Typ.	Max.	Unit	Conditions
<b>SUPPLY INPUT (VDD1, VDD2, and VDD3)</b>						
$V_{DD}$ Supply Voltage Range	$V_{DD}$	6	—	9.5	V	
$V_{DD}$ Undervoltage Lower Threshold	$V_{DD(UVLOF)}$	—	—	5.3	V	$V_{DD}$ falling ( <b>Note 1</b> )
$V_{DD}$ Undervoltage Hysteresis	$\Delta V_{DD(UVLO)}$	—	500	—	mV	
Operating Supply Current	$I_{DD}$	—	—	3	mA	Total of $V_{DD1} + V_{DD2} + V_{DD3}$ ( <b>Note 1</b> )
<b>HIGH VOLTAGE SWITCHES (DRAIN1 – RSENSE1, DRAIN2–RSENSE2, AND DRAIN3 – RSENSE3)</b>						
Breakdown Voltage	$V_{BR}$	210	—	—	V	<b>Note 1</b>
On-Resistance	$R_{ON}$	—	25	45	$\Omega$	$I_{DRAIN} = 50\text{ mA}$ , $V_{RSENSE} = 0\text{V}$
Drain Saturation Current	$I_{SAT}$	200	300	—	mA	$V_{DRAIN} = 120\text{V}$ , $V_{RSENSE} = 1.3\text{V}$ ( <b>Note 1</b> )
<b>CURRENT SENSE COMPARATORS (CS1 – REF1, CS2 – REF2, AND CS3 – REF3)</b>						
Short-Circuit Protection Overcurrent Limit Threshold	$V_{CS(LIM)}$	1	1.15	1.3	V	<b>Note 1</b>
Short-Circuit Recovery Delay	$T_{SKIP}$	—	200	—	$\mu\text{s}$	
Leading Edge Blanking Delay	$T_{BLANK}$	120	—	220	ns	
Input Offset Voltage	$V_{OS}$	-7	—	7	mV	<b>Note 1</b>
Propagation Delay CS-to-DRAIN	$T_{DELAY}$	—	—	150	ns	$V_{CS} - V_{REF} = 50\text{ mV}$ ( <b>Note 1</b> )
Short-Circuit Protection Delay CS-to-DRAIN	$T_{DELAY(LIM)}$	—	—	0.5	$\mu\text{s}$	$V_{CS} = V_{CS(LIM)} + 100\text{ mV}$ , $V_{REF} > V_{CS(LIM)}$ ( <b>Note 1</b> )
<b>OSCILLATOR INPUT AND FREQUENCY DIVIDER (CLK)</b>						
Maximum Switching Frequency	$F_{SW(MAX)}$	500	—	—	kHz	$f_{CLK} = 3\text{ MHz}$ ( <b>Note 1</b> )
Frequency Divider Ratio	$K_{SW}$	—	6	—	—	<b>Note 2</b>

**Note 1:** The specifications which apply over the full operating temperature range at  $-40^\circ\text{C} < T_A < +85^\circ\text{C}$  are guaranteed by design and characterization.

**2:** Guaranteed by design

## ELECTRICAL CHARACTERISTICS (CONTINUED)

Electrical Specifications:  $T_A = 25^\circ\text{C}$  and  $V_{DD} = 8\text{V}$  unless otherwise specified.

Parameter	Sym.	Min.	Typ.	Max.	Unit	Conditions
DRAIN1-DRAIN2 Phase Delay	$\phi_2$	—	120	—	deg	Note 2
DRAIN1-DRAIN3 Phase Delay	$\phi_3$	—	240	—	deg	Note 2
CLK High Time	$T_{OFF}$	50	—	—	ns	
CLK Low Time	$T_{ON}$	50	—	—	ns	
CLK Input High Voltage	$V_{CLK(HI)}$	2	—	—	V	Note 1
CLK Input Low Voltage	$V_{CLK(LO)}$	—	—	0.8	V	Note 1
<b>PWM DIMMING (PWMD1, PWMD2 AND PWMD3)</b>						
PWMD Input Low Voltage	$V_{PWMD(LO)}$	—	—	0.8	V	Note 1
PWMD Input High Voltage	$V_{PWMD(HI)}$	2	—	—	V	Note 1
PWMD Pull-Down Resistance	$R_{PWMD}$	100	200	300	k $\Omega$	$V_{PWMD} = 5\text{V}$
<b>OVERTEMPERATURE PROTECTION</b>						
Overtemperature Trip Limit	$T_{OT}$	125	140	—	$^\circ\text{C}$	Note 1
Overtemperature Hysteresis	$T_{OTHYST}$	—	60	—	$^\circ\text{C}$	Note 1

**Note 1:** The specifications which apply over the full operating temperature range at  $-40^\circ\text{C} < T_A < +85^\circ\text{C}$  are guaranteed by design and characterization.

**2:** Guaranteed by design

## TEMPERATURE SPECIFICATIONS

Parameter	Sym.	Min.	Typ.	Max.	Unit	Conditions
<b>TEMPERATURE RANGE</b>						
Operating Ambient Temperature	$T_A$	-40	—	+85	$^\circ\text{C}$	
Operating Junction Temperature	$T_J$	-40	—	+125	$^\circ\text{C}$	
Maximum Junction Temperature	$T_{J(ABSMAX)}$	—	—	+150	$^\circ\text{C}$	
Storage Temperature	$T_s$	-65	—	+150	$^\circ\text{C}$	
<b>PACKAGE THERMAL RESISTANCE</b>						
24-lead SOW	$\theta_{JA}$	—	60	—	$^\circ\text{C/W}$	

# HV9980

## 2.0 TYPICAL PERFORMANCE CURVES

**Note:** The graphs and tables provided following this note are a statistical summary based on a limited number of samples and are provided for informational purposes only. The performance characteristics listed herein are not tested or guaranteed. In some graphs or tables, the data presented may be outside the specified operating range (e.g. outside specified power supply range) and therefore outside the warranted range.

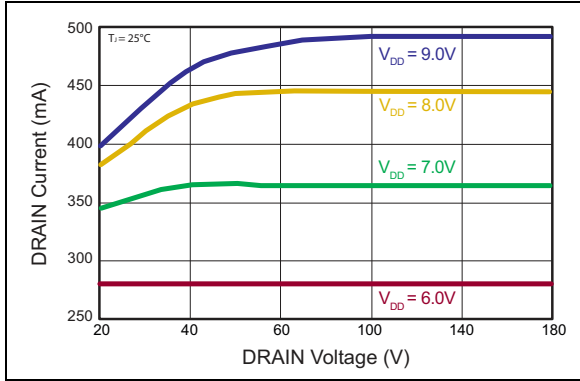

**FIGURE 2-1:** Output Saturation Current ( $I_{DRAIN}$  vs.  $V_{DRAIN}$  at  $V_{RSENSE} = 0V$ ).

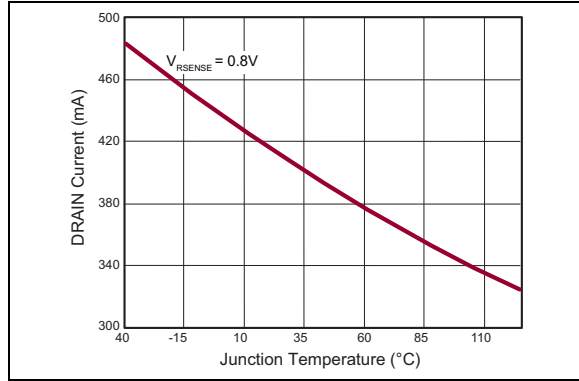

**FIGURE 2-4:** Output Saturation Current ( $I_{DRAIN}$  vs.  $T_J$  at  $V_{DD} = 9V$ ).

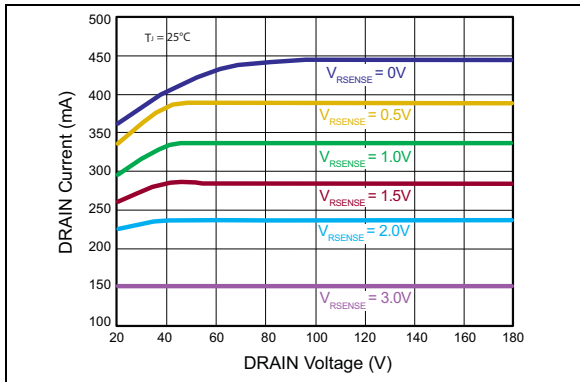

**FIGURE 2-2:** Output Saturation Current ( $I_{DRAIN}$  vs.  $V_{DRAIN}$  at  $V_{DD} = 8V$ ).

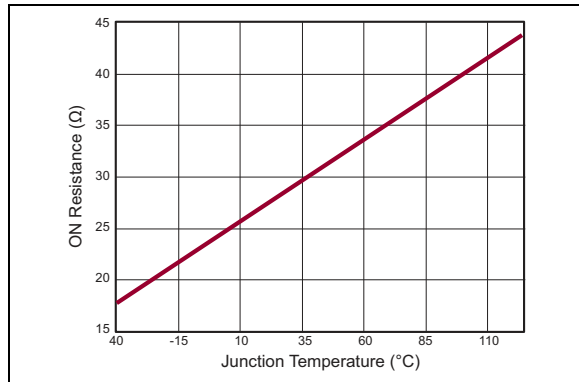

**FIGURE 2-5:** ON Resistance ( $R_{ON}$  vs.  $T_J$  at  $V_{DD} = 8V$  or  $9V$ ).

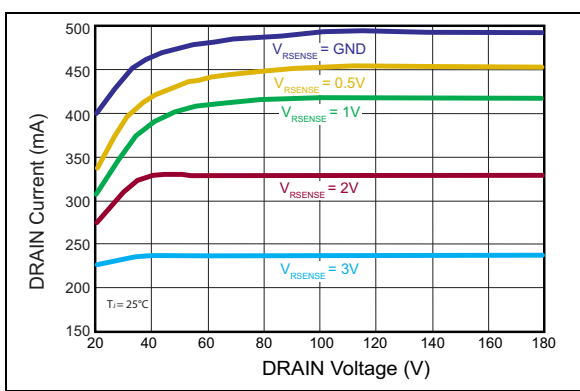

**FIGURE 2-3:** Output Saturation Current ( $I_{DRAIN}$  vs.  $V_{DRAIN}$  at  $V_{DD} = 9V$ ).

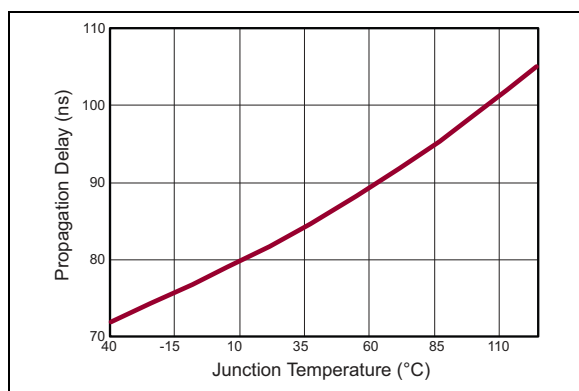

**FIGURE 2-6:** CS-to-DRAIN Propagation Delay ( $T_{DELAY}$  vs.  $T_J$  at  $V_{DD} = 8V$  or  $9V$ ).

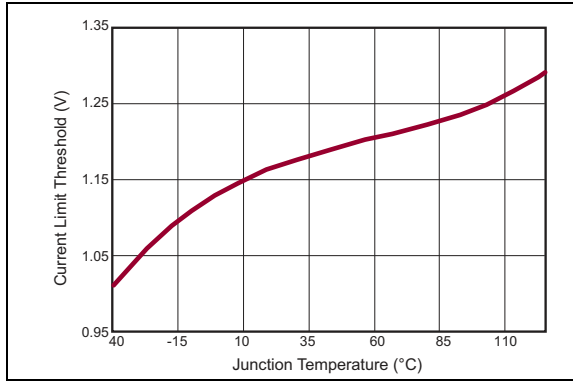

**FIGURE 2-7:** Short Circuit Current Limit Threshold Voltage ( $V_{CS(LIM)}$ ) vs.  $T_J$  at  $V_{DD} = 8V$  or  $9V$ .

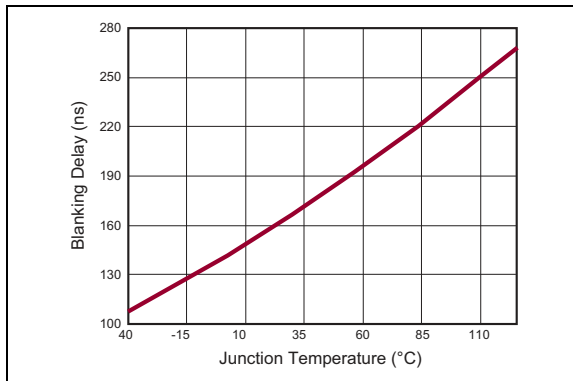

**FIGURE 2-8:** Leading Edge Blanking Delay ( $T_{BLANK}$ ) vs.  $T_J$  at  $V_{DD} = 8V$  or  $9V$ .

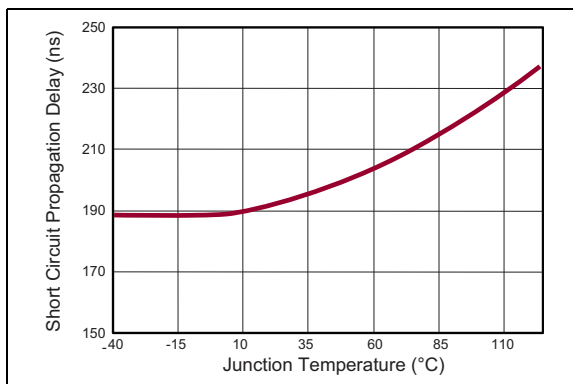

**FIGURE 2-9:** Short-Circuit Protection Delay ( $T_{DELAY(LIM)}$ ) vs.  $T_J$  at  $V_{DD} = 8V$  or  $9V$ .

## 3.0 PIN DESCRIPTION

Table 3-1 shows the description of pins in HV9980.

Refer to [Package Type](#) for the location of pins.

**TABLE 3-1: PIN FUNCTION TABLE**

Pin Number	Pin Name	Description
1	REF1	Voltage reference input to the current sense comparator. For best noise immunity, connect an RC filter at this pin referenced to the corresponding PGND1 pin. The filter can consist of a 1 nF low-impedance capacitor and a 1 kΩ resistor.
2	VDD1	Power supply input. For best noise immunity, bypass this pin to the corresponding PGND1 pin with a 0.1 μF low-impedance capacitor. The VDD pins must be tied together on the PCB.
3	CLK	Input to an external clock signal common to all three channels. Programs the switching frequency of the power MOSFET outputs at 1/6 of the clock signal frequency.
4	PWMD1	Dedicated PWM dimming input for individual LED string driver Channel 1
5	AGND	Common return pin for CLK, POL and PWMD inputs
6	POL	Must be connected to AGND
7	REF2	Voltage reference input to the current sense comparator. For best noise immunity, connect an RC filter at this pin referenced to the corresponding PGND2 pin. The filter can consist of a 1 nF low-impedance capacitor and a 1 kΩ resistor.
8	VDD2	Power supply input. For best noise immunity, bypass this pin to the corresponding PGND2 pin with a 0.1 μF low-impedance capacitor. The VDD pins must be tied together on the PCB.
9	PWMD2	Dedicated PWM dimming input for individual LED string driver Channel 2
10	REF3	Voltage reference input to the current sense comparator. For best noise immunity, connect an RC filter at this pin referenced to the corresponding PGND3 pin. The filter can consist of a 1 nF low-impedance capacitor and a 1 kΩ resistor.
11	VDD3	Power supply input. For best noise immunity, bypass this pin to the corresponding PGND3 pin with a 0.1 μF low-impedance capacitor. The VDD pins must be tied together on the PCB.
12	PWMD3	Dedicated PWM dimming input for individual LED string driver Channel 3
13	PGND3	Power return terminal for corresponding DRAIN3. The PGND and AGND pins must be tied together on the PCB.
14	CS3	Signal input to the current sense comparator. Connect this pin to the corresponding RSENSE3 output directly when the slope compensation feature is not used. When the slope compensation is needed, connect a capacitor between RSENSE3 and its corresponding CS3 pin, and connect a resistor between CS3 pin and VDD3.
15	RSENSE3	Open source output of the Channel 3 switching power MOSFET. Connect a current sense resistor between the RSENSE3 pin and its corresponding PGND3 pin.
16	DRAIN3	Open DRAIN output of the switching power MOSFET in Channel 3
17	DRAIN2	Open DRAIN output of the switching power MOSFET in Channel 2
18	RSENSE2	Open source output of the Channel 2 switching power MOSFET. Connect a current sense resistor between the RSENSE2 pin and its corresponding PGND2 pin.
19	CS2	Signal input to the current sense comparator. Connect this pin to the corresponding RSENSE2 output directly when the slope compensation feature is not used. When the slope compensation is needed, connect a capacitor between RSENSE2 and its corresponding CS2 pin, and connect a resistor between CS2 and VDD2.
20	PGND2	Power return terminal for corresponding DRAIN2 output. The PGND and AGND pins must be tied together on the PCB.
21	DRAIN1	Open DRAIN output of the switching power MOSFET in Channel 1
22	RSENSE1	Open source output of the Channel 1 switching power MOSFET. Connect a current sense resistor between the RSENSE1 pin and its corresponding PGND1 pin.

**TABLE 3-1: PIN FUNCTION TABLE**

Pin Number	Pin Name	Description
23	CS1	Signal input to the current sense comparator. Connect this pin to the corresponding RSENSE1 output directly when the slope compensation feature is not used. When the slope compensation is needed, connect a capacitor between RSENSE1 and its corresponding CS1 pin, and connect a resistor between CS1 pin and VDD1.
24	PGND1	Power return terminal for corresponding DRAIN1 output. The PGND and AGND pins must be tied together on the PCB.

## 4.0 APPLICATION INFORMATION

### 4.1 Programming LED Current and Selecting L and D

The required value of the output inductor, L, is inversely proportional to the ripple current,  $\Delta I_O$ , in it. Setting the relative peak-to-peak ripple to 20% to 30% of the average output current is a good practice to ensure the noise immunity of the current sense comparator. See [Equation 4-3](#).

#### EQUATION 4-1:

$$L = \frac{(V_O \times T_{OFF})}{\Delta I_O} = \frac{(V_O \times [1 - D])}{f_S \Delta I_O}$$

Where  $V_O$  is the forward voltage of the LED string,  $f_S$  is the switching frequency, and  $D = V_O/V_{IN}$  is the switching duty cycle.

The output current in each LED string ( $I_O$ ) is calculated as shown in [Equation 4-2](#).

#### EQUATION 4-2:

$$I_O = \left( \frac{V_{REF}}{R_{SENSE}} \right) - \frac{1}{2} \times \Delta I_O$$

Where  $V_{REF}$  is the voltage at REF1-3 and  $R_{SENSE}$  is the current sense resistor at RSENSE1-3. The ripple current introduces a peak-to-average error in the output current setting that needs to be accounted for.

Adding a filter capacitor across the LED string can reduce the output current ripple, yielding a reduced value of L. However, one must keep in mind that the peak-to-average current error is affected by the variation of the input and output voltage. Therefore, the line-and-load regulation of the LED current might be sacrificed at large ripple current in L.

Another important aspect of designing each LED driver channel with the HV9980 is related to certain parasitic elements of the circuit, including distributed coil capacitance  $C_L$  of L, junction capacitance,  $C_J$ , and reverse recovery time,  $t_{rr}$ , of the rectifier diode, D, capacitance of the PCB traces,  $C_{PCB}$ , and output capacitance,  $C_{DRAIN}$ , of the controller itself. These parasitic elements affect the efficiency of the switching converter and could potentially cause false triggering of the current sense comparator if not properly managed. Minimizing these parasitics is essential for efficient and reliable operation of the HV9980.

Coil capacitance of inductors is typically provided in the manufacturer's data books either directly or in terms of the self-resonant frequency (SRF). Refer to [Equation 4-3](#).

#### EQUATION 4-3:

$$SRF = \frac{1}{(2\pi\sqrt{L \times C_L})}$$

Where L is the inductance value, and  $C_L$  is the coil capacitance for the inductor in each driver channel.

Charging and discharging this capacitance every switching cycle causes high-current spikes in the LED string. Therefore, connecting a small capacitor,  $C_O$  (~10 nF), is recommended to bypass these spikes.

Using an ultra-fast rectifier diode for D is recommended to achieve high efficiency and reduce the risk of false triggering of the current sense comparator. Using diodes with shorter reverse recovery time,  $t_{rr}$ , and lower junction capacitance,  $C_J$ , achieves better performance. The reverse voltage rating,  $V_R$ , of the diode must be greater than the maximum input voltage of the LED lamp.

The total parasitic capacitance present at the DRAIN output of the HV9980 can be calculated as shown in [Equation 4-5](#).

#### EQUATION 4-4:

$$C_P = C_{DRAIN} + C_{PCB} + C_L + C_J$$

When the switch turns on, the capacitance,  $C_P$ , is discharged into the DRAIN output of the IC. The discharge current is limited to typically 300 mA of the internal MOSFET switch saturation current. However, it may become lower at increased junction temperature. The duration of the leading edge current spike can be estimated as shown in [Equation 4-5](#).

#### EQUATION 4-5:

$$T_{SPIKE} = [(V_{IN} \cdot C_P) / I_{SAT}] + t_{rr}$$

In order to avoid false triggering of the current sense comparator  $C_P$  must be minimized in accordance with [Equation 4-6](#).

#### EQUATION 4-6:

$$C_P < \frac{(I_{SAT} \times [T_{BLANK(MIN)} - t_{rr}])}{V_{IN(MAX)}}$$

Where  $T_{BLANK(MIN)}$  is the minimum blanking time 120 ns, and  $V_{IN(MAX)}$  is the maximum instantaneous input voltage.

## 4.2 Layout Considerations

The HV9980 provides three independent power ground connections, PGND1-3, for each channel. The PGND pins must be wired together on the PCB. To minimize interference between the channels, the PGND pins should be wired to the negative terminal of the input filter capacitor,  $C_{IN}$ , using separate tracks. All three power supply inputs VDD1, VDD2, and VDD3 must also be connected together on the PCB.

Although in many layout arrangements wiring the reference pins, REF1-3, together is acceptable, further reduction of the “cross-talk” between the channels is possible by adding low-pass RC filters with the filter capacitors referenced to the corresponding PGND pins. These filters composed from  $R_{REF1-3}$  and  $C_{REF1-3}$  are shown in the [Typical Application Circuit](#).

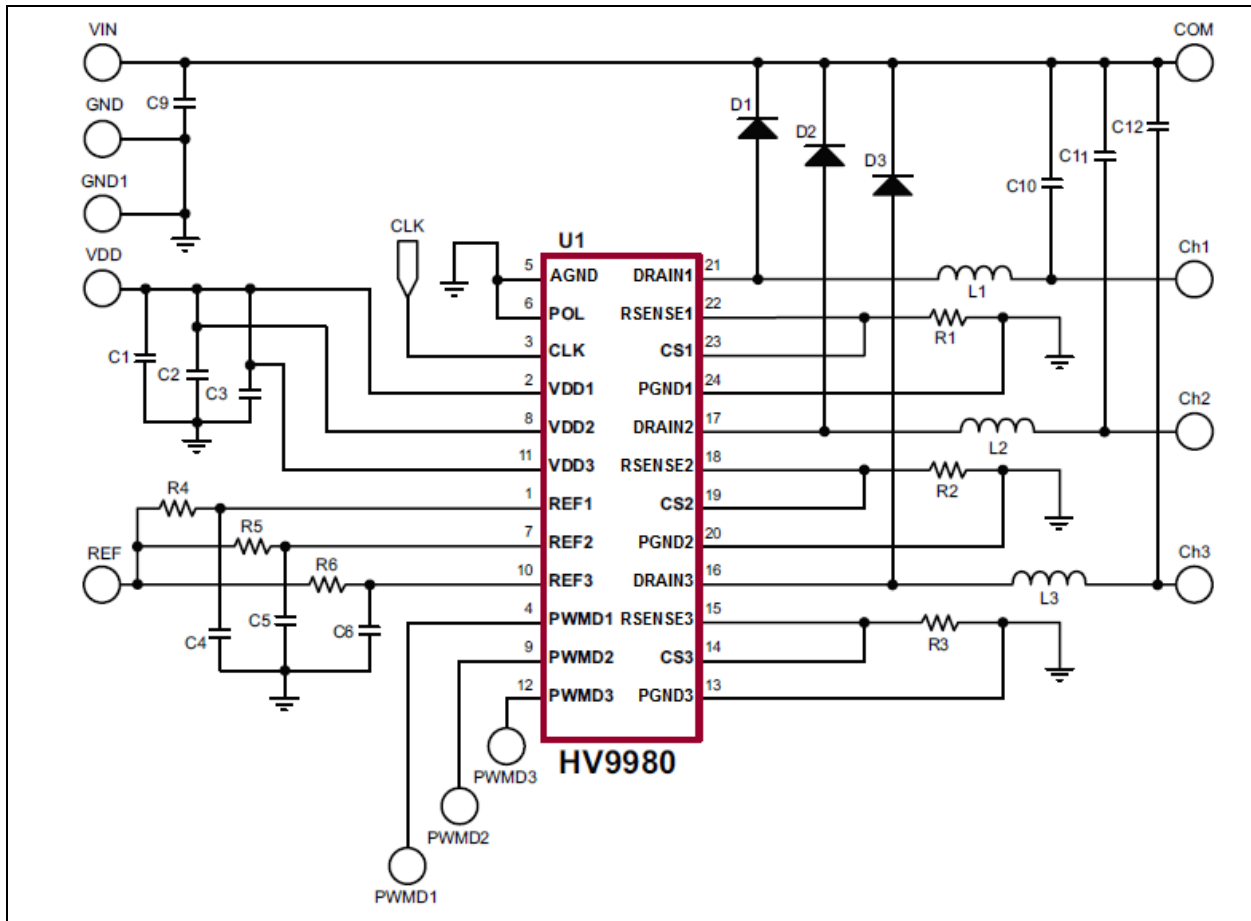

**FIGURE 4-1:** 110 VDC–190 VDC 3-channel 50V 70 mA LED Driver Schematic.

# HV9980

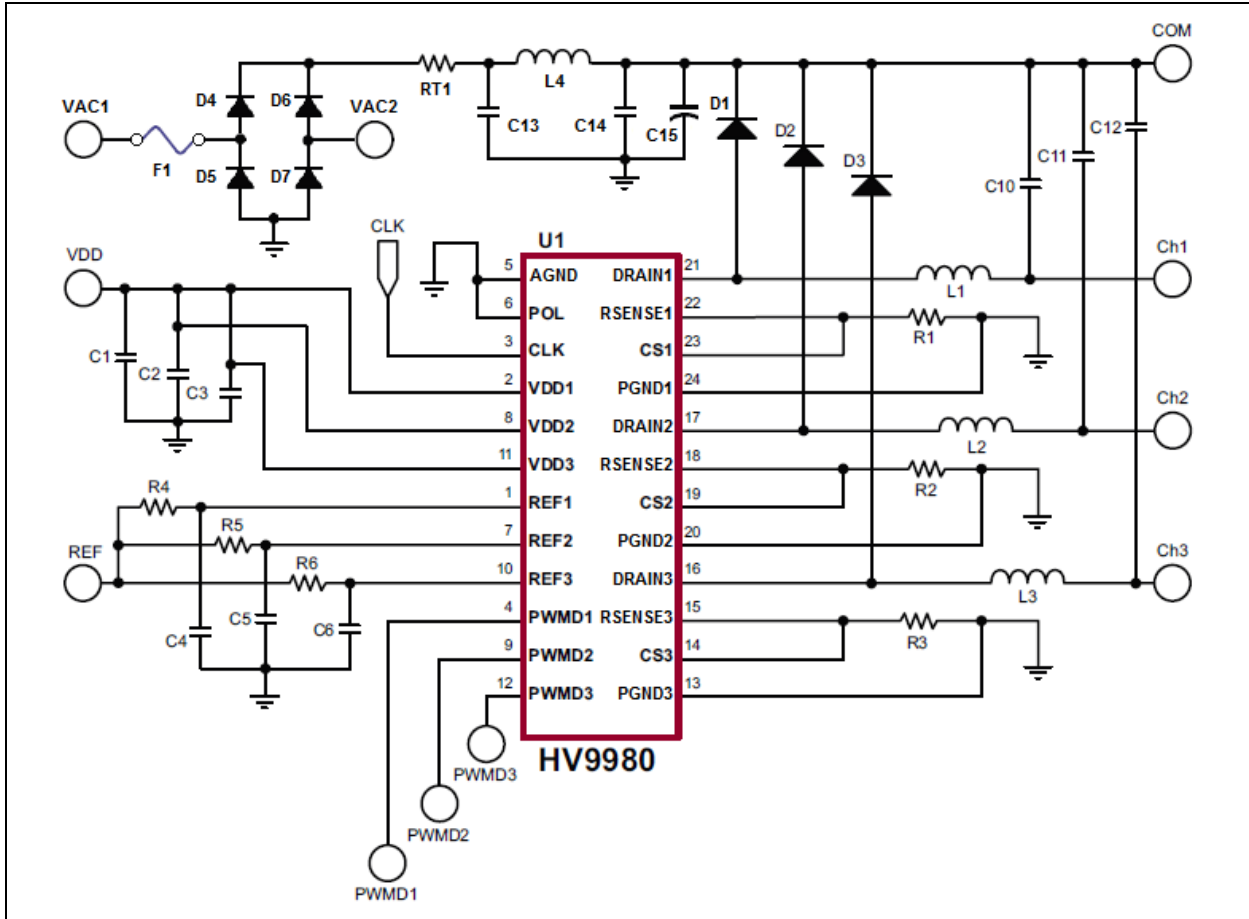

**FIGURE 4-2:** 90 VAC–135 VAC 3-channel 50V 70 mA LED Driver Schematic.

## 5.0 PACKAGING INFORMATION

### 5.1 Package Marking Information

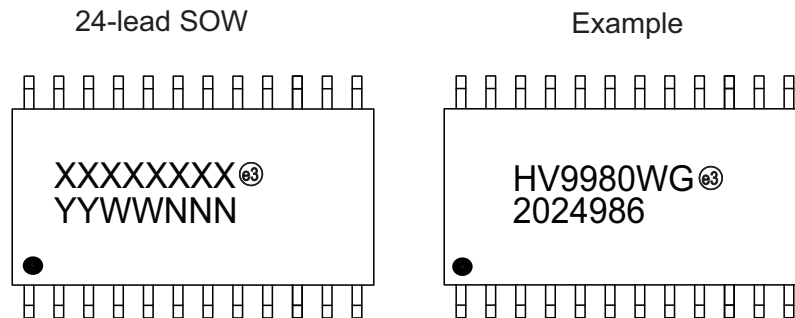

<b>Legend:</b>	XX...X	Product Code or Customer-specific information
	Y	Year code (last digit of calendar year)
	YY	Year code (last 2 digits of calendar year)
	WW	Week code (week of January 1 is week '01')
	NNN	Alphanumeric traceability code
	(e3)	Pb-free JEDEC® designator for Matte Tin (Sn)
	*	This package is Pb-free. The Pb-free JEDEC designator (e3) can be found on the outer packaging for this package.
<b>Note:</b>	In the event the full Microchip part number cannot be marked on one line, it will be carried over to the next line, thus limiting the number of available characters for product code or customer-specific information. Package may or not include the corporate logo.	

## 24-Lead SOW (Wide Body) Package Outline (WG) 15.40x7.50 body, 2.65mm height (max), 1.27mm pitch

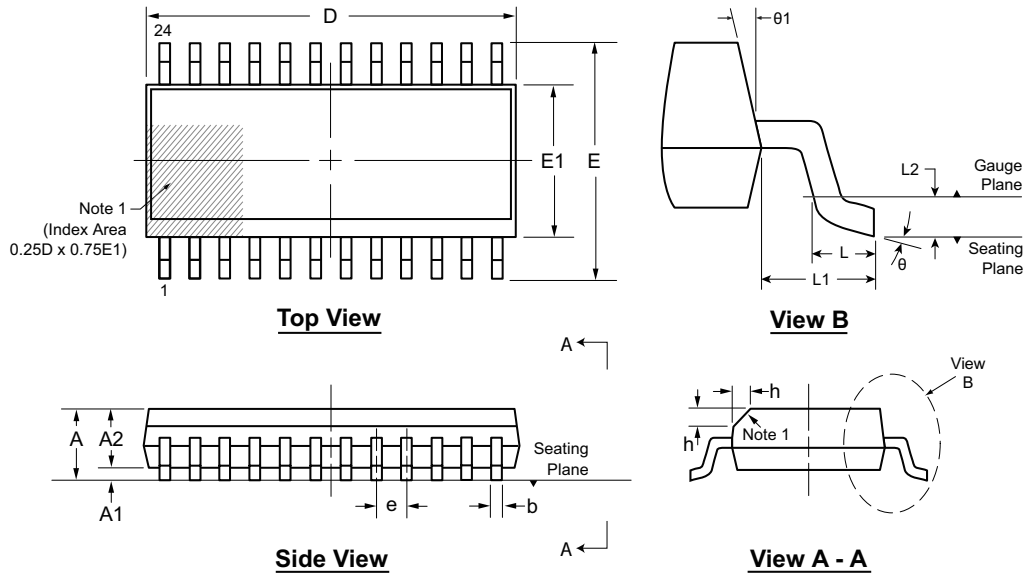

Note: For the most current package drawings, see the Microchip Packaging Specification at [www.microchip.com/packaging](http://www.microchip.com/packaging).

**Note:**

1. A Pin 1 identifier must be located in the index area indicated. The Pin 1 identifier can be: a molded mark/identifier; an embedded metal marker; or a printed indicator.

Symbol	A	A1	A2	b	D	E	E1	e	h	L	L1	L2	$\theta$	$\theta 1$	
Dimension (mm)	MIN	2.15*	0.10	2.05	0.31	15.20*	9.97*	7.40*	1.27 BSC	0.25	0.40	1.40 REF	0.25 BSC	0°	5°
	NOM	-	-	-	-	15.40	10.30	7.50		-	-		-	-	
	MAX	2.65	0.30	2.55*	0.51	15.60*	10.63*	7.60*		0.75	1.27		8°	15°	

JEDEC Registration MS-013, Variation AD, Issue E, Sep. 2005.

\* This dimension is not specified in the JEDEC drawing.

Drawings are not to scale.

## APPENDIX A: REVISION HISTORY

### Revision A (January 2020)

- Converted Supertex Document # DSFP-HV9980 to DS20005915A
- Changed the package marking format
- Made minor changes throughout the document

# HV9980

## PRODUCT IDENTIFICATION SYSTEM

To order or obtain information, e.g., on pricing or delivery, contact your local Microchip representative or sales office.

<u>PART NO.</u>	<u>XX</u>	-	<u>X</u>	-	<u>X</u>
Device	Package Options		Environmental		Media Type
Device:	HV9980	=	3-Channel LED Array Driver IC		
Package:	WG	=	24-lead SOW		
Environmental:	G	=	Lead (Pb)-free/RoHS-compliant Package		
Media Type:	(blank)	=	1000/Reel for a WG Package		

**Example:**

a) HV9980WG-G: 3-Channel LED Array Driver IC, 24-lead SOW Package, 1000/Reel

---

---

**Note the following details of the code protection feature on Microchip devices:**

- Microchip products meet the specification contained in their particular Microchip Data Sheet.
- Microchip believes that its family of products is one of the most secure families of its kind on the market today, when used in the intended manner and under normal conditions.
- There are dishonest and possibly illegal methods used to breach the code protection feature. All of these methods, to our knowledge, require using the Microchip products in a manner outside the operating specifications contained in Microchip's Data Sheets. Most likely, the person doing so is engaged in theft of intellectual property.
- Microchip is willing to work with the customer who is concerned about the integrity of their code.
- Neither Microchip nor any other semiconductor manufacturer can guarantee the security of their code. Code protection does not mean that we are guaranteeing the product as “unbreakable.”

Code protection is constantly evolving. We at Microchip are committed to continuously improving the code protection features of our products. Attempts to break Microchip's code protection feature may be a violation of the Digital Millennium Copyright Act. If such acts allow unauthorized access to your software or other copyrighted work, you may have a right to sue for relief under that Act.

---

Information contained in this publication regarding device applications and the like is provided only for your convenience and may be superseded by updates. It is your responsibility to ensure that your application meets with your specifications. MICROCHIP MAKES NO REPRESENTATIONS OR WARRANTIES OF ANY KIND WHETHER EXPRESS OR IMPLIED, WRITTEN OR ORAL, STATUTORY OR OTHERWISE, RELATED TO THE INFORMATION, INCLUDING BUT NOT LIMITED TO ITS CONDITION, QUALITY, PERFORMANCE, MERCHANTABILITY OR FITNESS FOR PURPOSE. Microchip disclaims all liability arising from this information and its use. Use of Microchip devices in life support and/or safety applications is entirely at the buyer's risk, and the buyer agrees to defend, indemnify and hold harmless Microchip from any and all damages, claims, suits, or expenses resulting from such use. No licenses are conveyed, implicitly or otherwise, under any Microchip intellectual property rights unless otherwise stated.

### Trademarks

The Microchip name and logo, the Microchip logo, Adaptec, AnyRate, AVR, AVR logo, AVR Freaks, BesTime, BitCloud, chipKIT, chipKIT logo, CryptoMemory, CryptoRF, dsPIC, FlashFlex, flexPWR, HELDO, IGLoo, JukeBlox, KeeLoq, Klear, LANCheck, LinkMD, maXStylus, maXTouch, MediaLB, megaAVR, Microsemi, Microsemi logo, MOST, MOST logo, MPLAB, OptoLyzer, PackeTime, PIC, picoPower, PICSTART, PIC32 logo, PolarFire, Prochip Designer, QTouch, SAM-BA, SenGenuity, SpyNIC, SST, SST Logo, SuperFlash, Symmetricom, SyncServer, Tachyon, TempTrackr, TimeSource, tinyAVR, UNI/O, Vectron, and XMEGA are registered trademarks of Microchip Technology Incorporated in the U.S.A. and other countries.

APT, ClockWorks, The Embedded Control Solutions Company, EtherSynch, FlashTec, Hyper Speed Control, HyperLight Load, IntelliMOS, Libero, motorBench, mTouch, Powermite 3, Precision Edge, ProASIC, ProASIC Plus, ProASIC Plus logo, Quiet-Wire, SmartFusion, SyncWorld, Temux, TimeCesium, TimeHub, TimePictra, TimeProvider, Vite, WinPath, and ZL are registered trademarks of Microchip Technology Incorporated in the U.S.A.

Adjacent Key Suppression, AKS, Analog-for-the-Digital Age, Any Capacitor, AnyIn, AnyOut, BlueSky, BodyCom, CodeGuard, CryptoAuthentication, CryptoAutomotive, CryptoCompanion, CryptoController, dsPICDEM, dsPICDEM.net, Dynamic Average Matching, DAM, ECAN, EtherGREEN, In-Circuit Serial Programming, ICSP, INICnet, Inter-Chip Connectivity, JitterBlocker, KlearNet, KlearNet logo, memBrain, Mindi, MiWi, MPASM, MPF, MPLAB Certified logo, MPLIB, MPLINK, MultiTRAK, NetDetach, Omniscient Code Generation, PICDEM, PICDEM.net, PICkit, PICtail, PowerSmart, PureSilicon, QMatrix, REAL ICE, Ripple Blocker, SAM-ICE, Serial Quad I/O, SMART-I.S., SQI, SuperSwitcher, SuperSwitcher II, Total Endurance, TSHARC, USBCheck, VariSense, ViewSpan, WiperLock, Wireless DNA, and ZENA are trademarks of Microchip Technology Incorporated in the U.S.A. and other countries.

SQTP is a service mark of Microchip Technology Incorporated in the U.S.A.

The Adaptec logo, Frequency on Demand, Silicon Storage Technology, and Symmcom are registered trademarks of Microchip Technology Inc. in other countries.

GestIC is a registered trademark of Microchip Technology Germany II GmbH & Co. KG, a subsidiary of Microchip Technology Inc., in other countries.

All other trademarks mentioned herein are property of their respective companies.

© 2020, Microchip Technology Incorporated, All Rights Reserved.

ISBN:978-1-5224-5506-6

For information regarding Microchip's Quality Management Systems, please visit [www.microchip.com/quality](http://www.microchip.com/quality).



# MICROCHIP

## Worldwide Sales and Service

### AMERICAS

**Corporate Office**  
2355 West Chandler Blvd.  
Chandler, AZ 85224-6199  
Tel: 480-792-7200  
Fax: 480-792-7277  
Technical Support:  
<http://www.microchip.com/support>  
Web Address:  
[www.microchip.com](http://www.microchip.com)

#### Atlanta

Duluth, GA  
Tel: 678-957-9614  
Fax: 678-957-1455

#### Austin, TX

Tel: 512-257-3370

#### Boston

Westborough, MA  
Tel: 774-760-0087  
Fax: 774-760-0088

#### Chicago

Itasca, IL  
Tel: 630-285-0071  
Fax: 630-285-0075

#### Dallas

Addison, TX  
Tel: 972-818-7423  
Fax: 972-818-2924

#### Detroit

Novi, MI  
Tel: 248-848-4000

#### Houston, TX

Tel: 281-894-5983

#### Indianapolis

Noblesville, IN  
Tel: 317-773-8323  
Fax: 317-773-5453  
Tel: 317-536-2380

#### Los Angeles

Mission Viejo, CA  
Tel: 949-462-9523  
Fax: 949-462-9608  
Tel: 951-273-7800

#### Raleigh, NC

Tel: 919-844-7510

#### New York, NY

Tel: 631-435-6000

#### San Jose, CA

Tel: 408-735-9110  
Tel: 408-436-4270

#### Canada - Toronto

Tel: 905-695-1980  
Fax: 905-695-2078

### ASIA/PACIFIC

**Australia - Sydney**  
Tel: 61-2-9868-6733

**China - Beijing**  
Tel: 86-10-8569-7000

**China - Chengdu**  
Tel: 86-28-8665-5511

**China - Chongqing**  
Tel: 86-23-8980-9588

**China - Dongguan**  
Tel: 86-769-8702-9880

**China - Guangzhou**  
Tel: 86-20-8755-8029

**China - Hangzhou**  
Tel: 86-571-8792-8115

**China - Hong Kong SAR**  
Tel: 852-2943-5100

**China - Nanjing**  
Tel: 86-25-8473-2460

**China - Qingdao**  
Tel: 86-532-8502-7355

**China - Shanghai**  
Tel: 86-21-3326-8000

**China - Shenyang**  
Tel: 86-24-2334-2829

**China - Shenzhen**  
Tel: 86-755-8864-2200

**China - Suzhou**  
Tel: 86-186-6233-1526

**China - Wuhan**  
Tel: 86-27-5980-5300

**China - Xian**  
Tel: 86-29-8833-7252

**China - Xiamen**  
Tel: 86-592-2388138

**China - Zhuhai**  
Tel: 86-756-3210040

### ASIA/PACIFIC

**India - Bangalore**  
Tel: 91-80-3090-4444

**India - New Delhi**  
Tel: 91-11-4160-8631

**India - Pune**  
Tel: 91-20-4121-0141

**Japan - Osaka**  
Tel: 81-6-6152-7160

**Japan - Tokyo**  
Tel: 81-3-6880-3770

**Korea - Daegu**  
Tel: 82-53-744-4301

**Korea - Seoul**  
Tel: 82-2-554-7200

**Malaysia - Kuala Lumpur**  
Tel: 60-3-7651-7906

**Malaysia - Penang**  
Tel: 60-4-227-8870

**Philippines - Manila**  
Tel: 63-2-634-9065

**Singapore**  
Tel: 65-6334-8870

**Taiwan - Hsin Chu**  
Tel: 886-3-577-8366

**Taiwan - Kaohsiung**  
Tel: 886-7-213-7830

**Taiwan - Taipei**  
Tel: 886-2-2508-8600

**Thailand - Bangkok**  
Tel: 66-2-694-1351

**Vietnam - Ho Chi Minh**  
Tel: 84-28-5448-2100

### EUROPE

**Austria - Wels**  
Tel: 43-7242-2244-39  
Fax: 43-7242-2244-393

**Denmark - Copenhagen**  
Tel: 45-4450-2828  
Fax: 45-4485-2829

**Finland - Espoo**  
Tel: 358-9-4520-820

**France - Paris**  
Tel: 33-1-69-53-63-20  
Fax: 33-1-69-30-90-79

**Germany - Garching**  
Tel: 49-8931-9700

**Germany - Haan**  
Tel: 49-2129-3766400

**Germany - Heilbronn**  
Tel: 49-7131-72400

**Germany - Karlsruhe**  
Tel: 49-721-625370

**Germany - Munich**  
Tel: 49-89-627-144-0  
Fax: 49-89-627-144-44

**Germany - Rosenheim**  
Tel: 49-8031-354-560

**Israel - Ra'anana**  
Tel: 972-9-744-7705

**Italy - Milan**  
Tel: 39-0331-742611  
Fax: 39-0331-466781

**Italy - Padova**  
Tel: 39-049-7625286

**Netherlands - Drunen**  
Tel: 31-416-690399  
Fax: 31-416-690340

**Norway - Trondheim**  
Tel: 47-7288-4388

**Poland - Warsaw**  
Tel: 48-22-3325737

**Romania - Bucharest**  
Tel: 40-21-407-87-50

**Spain - Madrid**  
Tel: 34-91-708-08-90  
Fax: 34-91-708-08-91

**Sweden - Gothenberg**  
Tel: 46-31-704-60-40

**Sweden - Stockholm**  
Tel: 46-8-5090-4654

**UK - Wokingham**  
Tel: 44-118-921-5800  
Fax: 44-118-921-5820