

MFE. | Push-pull clamps

Steel



- 1
- 2
- 3
- 4
- 5
- 6
- 7
- 8
- 9
- 10
- 11
- 12
- 13
- 14
- 15
- 16
- 17
- 18

MATERIAL

C10 zinc-plated steel.

RIVETS

Zinc-plated steel.

PUSH LEVER

Zinc-plated steel.

REFERENCE BUSHING

Zinc-plated steel.

NUT

Zinc-plated steel.

BUSHING FIXING SCREWS

Zinc-plated steel.

HANDLE

Polyurethane, red colour.

FIXING SQUARE

Zinc-plated steel (to be ordered separately).

CLAMPING BOLTS

To be ordered separately.

FEATURES AND APPLICATIONS

All articulated joints are lubricated with special grease. Thanks to the front outer thread, MFE. clamps can be mounted in a way that the control lever is conveniently positioned using fixing squares (to be ordered separately), or frontally directly on the equipment. Both push and pull clamping can be performed effectively.

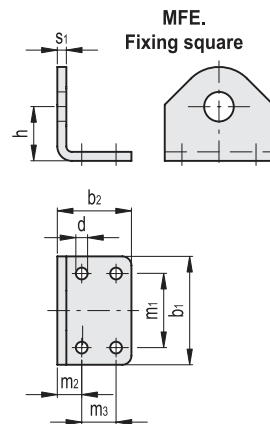
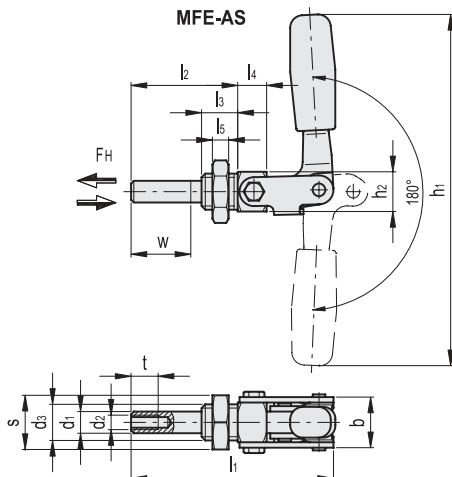
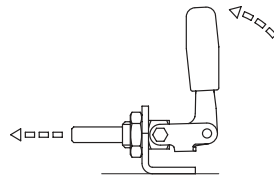

MFE-AS

Code	Description	b	d1	d2	d3	h1	h2	l1	l2	l3	l4	l5	s	t	Stroke w	FH [N]*	ΔΔ
GG.AG401	MFE.80-AS	24	10	M6	M16x1.5	120	19	71	38	15.5	10	8	24	12	21	3000	135
GG.AG406	MFE.165-AS	28	12	M8	M20x1.5	194	22	113	59	20	16	9	30	15	38	5400	335
GG.AG411	MFE.340-AS	38	16	M10	M24x2	256	30	173	90	22	28	10	36	18	66	7000	835

METRIC

MFE.

Code	Description	b1	b2	d	h	m1	m2	m3	s1	For MFE
GG.AG416	MFE.30080	35	22	5.5	24	20	12	-	4	MFE.80-AS
GG.AG421	MFE.30165	60	41	6.5	32	41	13.5	19	5	MFE.165-AS
GG.AG426	MFE.30340	75	59	8.5	48	55	19	25	5	MFE.340-AS

METRIC

Toggle clamps

* Holding force.