

4 3 2 1

REVISIONS				
ZONE	REV	DESCRIPTION	DATE	DRAWN
	A	Release For Tooling	09/23/02	MARTIN

D
C
B
A

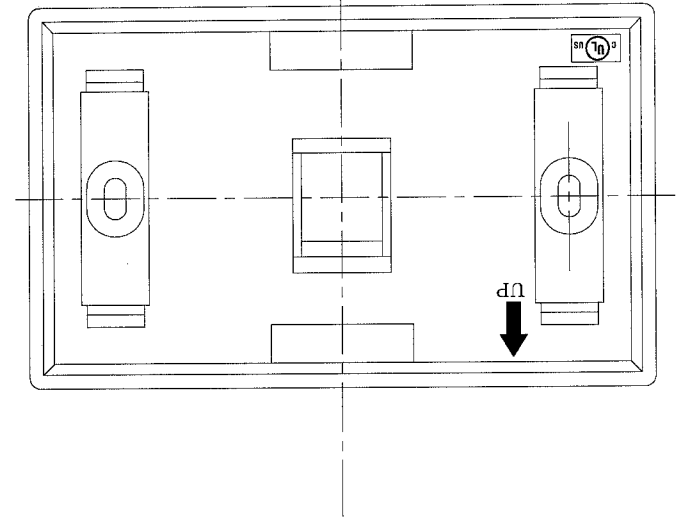
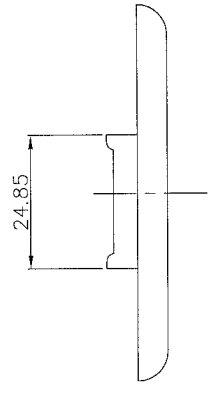
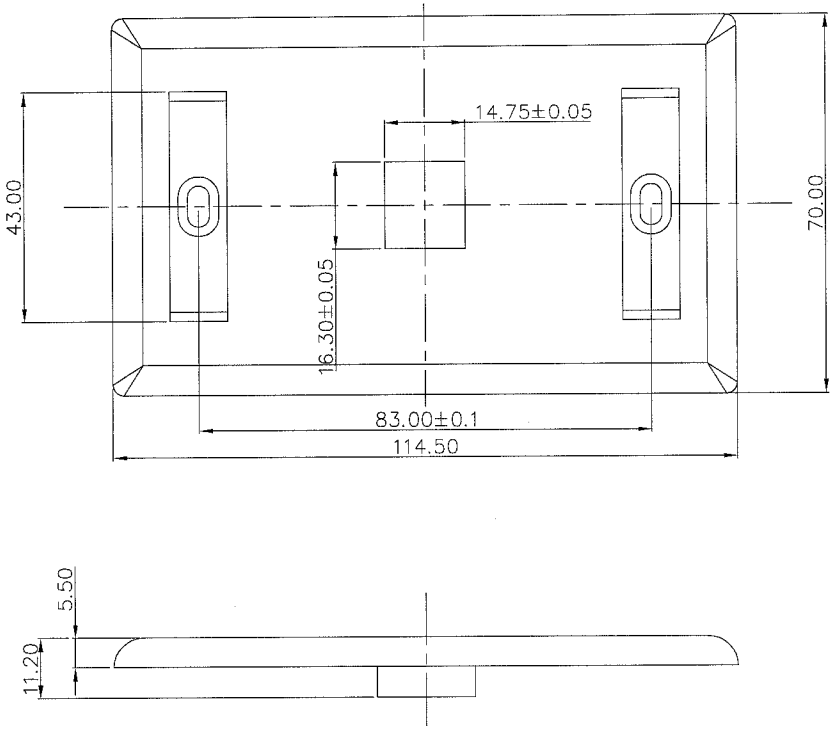

NOTE:
MOUNTING SCREWS INCLUDED

UNLESS OTHERWISE SPECIFIED: TOLERANCES		PROJECT ID 2031PH1		HellemannTyton.		
DECIMAL	-20 ±0.1mm	ANGULAR	±0°50'			
OVER 20-50	±0.15mm			P1681.DWG		HORIZONTAL FACE PLATE (1 PORT)
OVER 50-	±0.2mm			MATERIAL	DRAWN	
				ABS 94-V0	MARTIN	09/23/02
				SURFACE	CHECK	
				FINISH	APPROVED	
				MT11020		
SIZE	DRAWING NUMBER	PART NUMBER	REV			
A4	P1681	FPIHSINGLE	A			
SCALE	UNIT	SHEET	OF			
1:1	MM	1	1			

REC'D NOV 12 2002

XMI-DYNA062CST