

ORDER NO.	WOODHEAD NO.	COLOR
130144-0019	25T04	BLACK

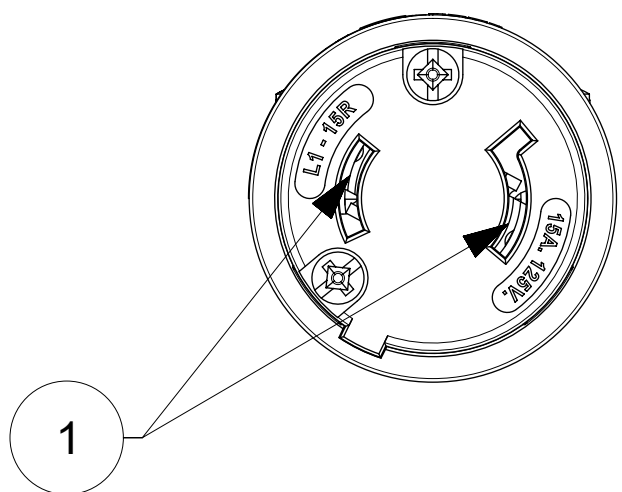

FACE VIEW

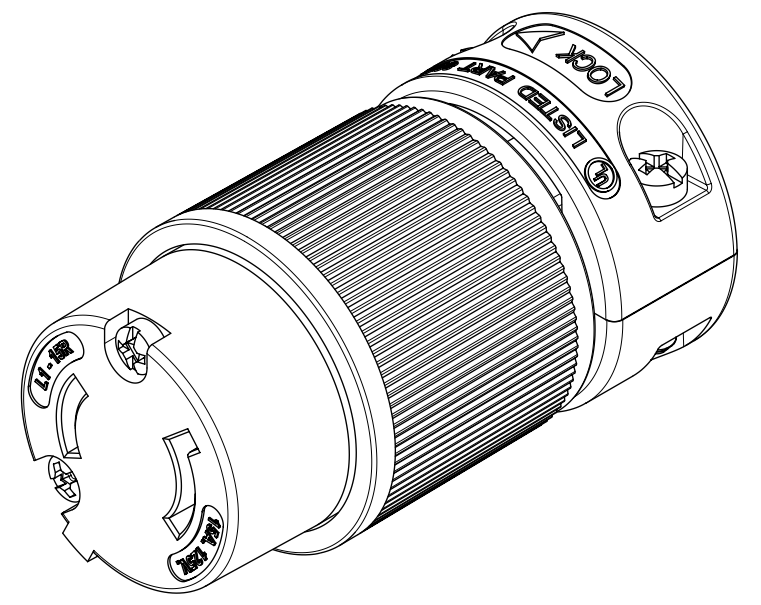
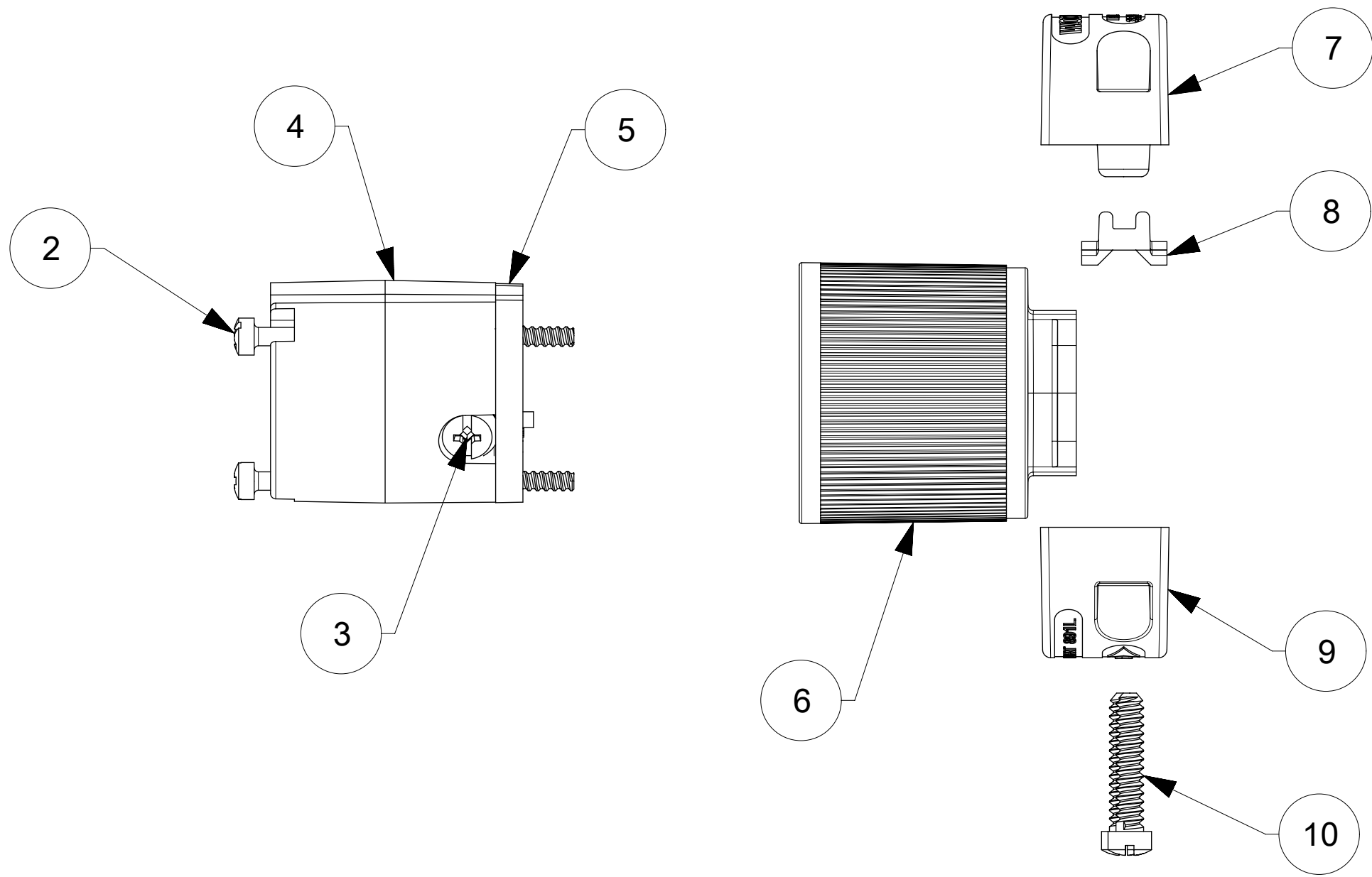
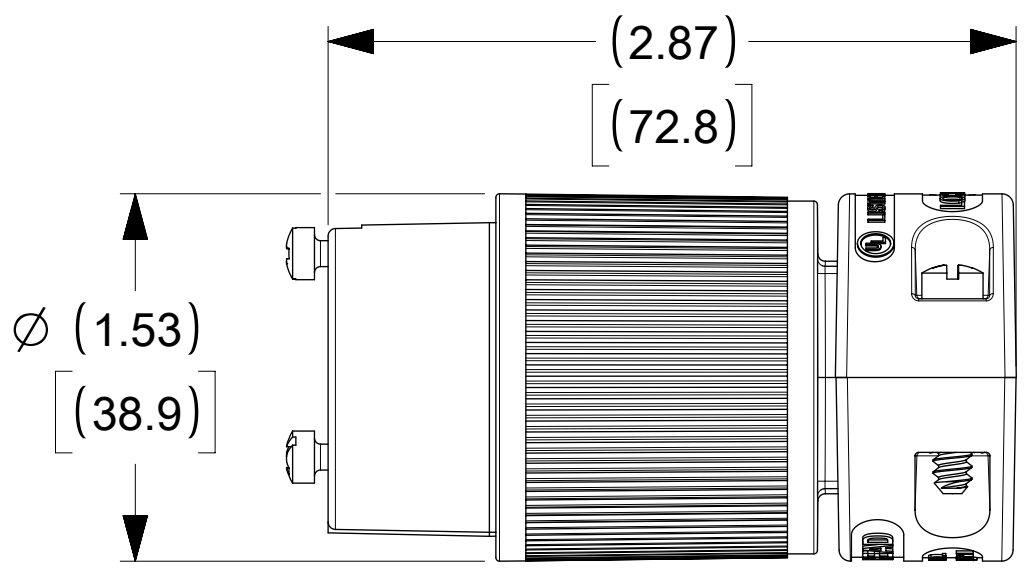

WIRING TERMINATION

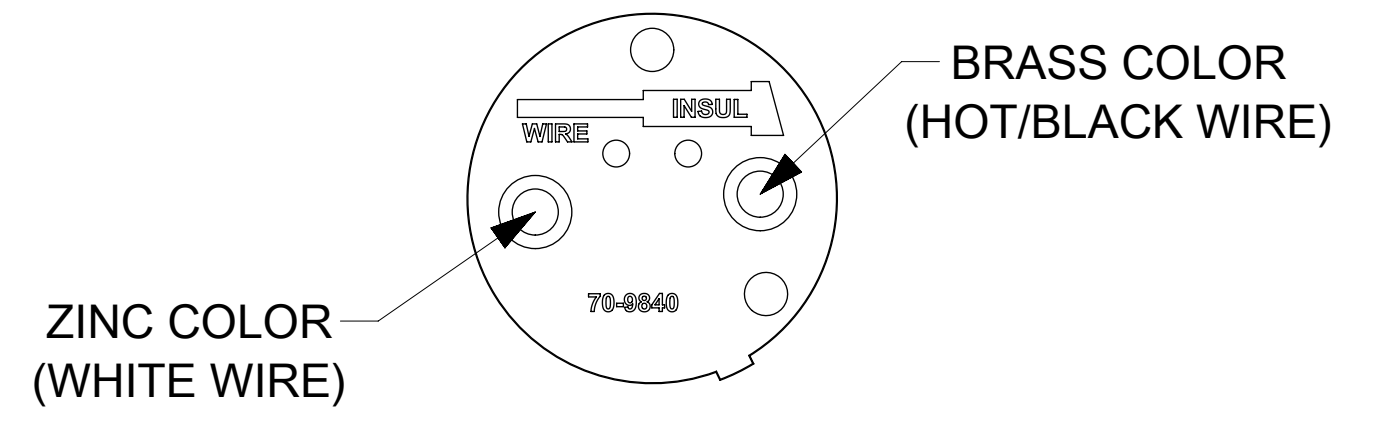

ITEM NO.	DESCRIPTIONS	MATERIAL	QTY.
1	BLADES	BRASS	2
2	RETAINING SCREWS	STAINLESS STEEL	2
3	TERMINAL SCREWS/CLAMP ASSEMBLY	BRASS, ZINC PLATED	2
4	INSERT	NYLON	1
5	TERMINAL COVER	POLYCARBONATE	1
6	HOUSING 20A	NYLON	1
7	CLAMP CORD MALE 20A	NYLON	1
8	CLAMP CORD 20A INSERT	NYLON	1
9	CLAMP CORD FEMALE 20A	NYLON	1
10	RETAINING SCREWS	STEEL, ZINC PLATED	2

SYMBOLS DIMENSION UNITS: INCH[MM] SCALE: NTS CURRENT REV DESC: NEW RELEASE		molex SAFEWAY CONNECTOR TURNEX 2P2W L1-15	
GENERAL TOLERANCES (UNLESS SPECIFIED) 4 PLACES ± 3 PLACES ± 2 PLACES ± 1 PLACE ± 0 PLACES ±		EC NO: 621489 DRWN: VBASUTHKARP 2019/02/28 CHK'D: DNGUYEN62 2019/12/02 APPR: HKNEELAND 2020/01/13	
DRAFT WHERE APPLICABLE MUST REMAIN WITHIN DIMENSIONS		PRODUCT CUSTOMER DRAWING DOCUMENT NUMBER: 1301440019 DOC TYPE: PSD DOC PART: 000 REVISION: A	
THIRD ANGLE PROJECTION		MATERIAL NUMBER: SEE TABLE CUSTOMER: GENERAL MARKET SHEET NUMBER: 1 OF 1	