

PART NO.	BASE TYPE	VOLTS	AMPS	WATTS	MSCP	FILAMENT TYPE	AVERAGE LIFE HOURS
787	G4 BI-PIN	6	1.67 ±10%	10	12 ±25%	C-6	100

REVISIONS			
REV	DESCRIPTION	DATE	APPROVED
1	ISSUED	11/20/2012	D.C.
2	REVISED MSCP AND DIMENSIONS	05/21/2013	D.C.

T2-3/4

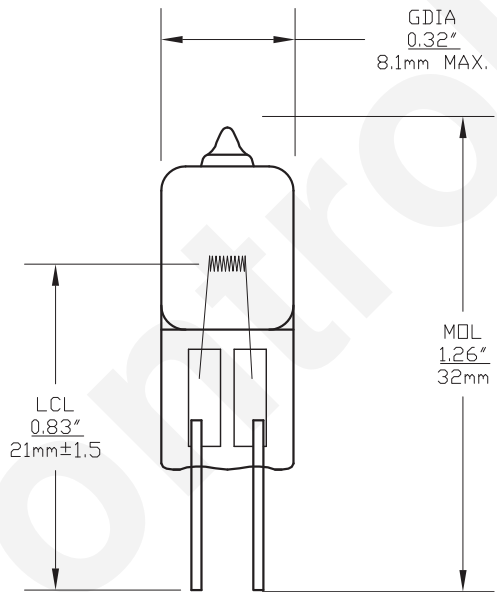

UNLESS OTHERWISE SPECIFIED: DIMENSIONS ARE IN INCHES TOLERANCES		CEC INDUSTRIES LTD			
DECIMALS .XX ± .05 .XXX ± .010 FRACTIONAL ±1/64		599 BOND STREET		LINCOLNSHIRE, IL 60069	
DRAWN D.C.		DATE 11/20/2012		TITLE HALOGEN LIGHT BULB NO. 787	
CHECKED		SIZE A	FSCM NO.	DWG NO. 787	REV 1
DESIGN		SCALE		PLOT SCALE	SHEET 1 OF 1
MATERIAL		FILE 787.dwg		DO NOT SCALE DRAWING	