

# INA826S Precision, 200- $\mu$ A Supply Current, 3-V to 36-V Supply Instrumentation Amplifier With Rail-to-Rail Output and Shutdown

## 1 Features

- Input Common-Mode Range: Includes  $V^-$
- Common-Mode Rejection:
  - 104 dB (Min,  $G = 10$ )
  - 100 dB (Min at 5 kHz,  $G = 10$ )
- Power-Supply Rejection: 100 dB (Min,  $G = 1$ )
- Low Offset Voltage: 150  $\mu$ V, max
- Gain Drift: 1 ppm/ $^{\circ}$ C ( $G = 1$ ), 35 ppm/ $^{\circ}$ C ( $G > 1$ )
- Noise: 18 nV/ $\sqrt{\text{Hz}}$ ,  $G \geq 100$
- Bandwidth: 1 MHz ( $G = 1$ ), 60 kHz ( $G = 100$ )
- Inputs Protected up to  $\pm 40$  V
- Rail-to-Rail Output
- Supply Current: 200  $\mu$ A
  - Shutdown Current: 2  $\mu$ A
- Supply Range:
  - Single Supply: 3 V to 36 V
  - Dual Supply:  $\pm 1.5$  V to  $\pm 18$  V
- Specified Temperature Range:  $-40^{\circ}$ C to  $+125^{\circ}$ C
- Packages: 3-mm  $\times$  3-mm VSON

## 2 Applications

- Industrial Process Controls
- Circuit Breakers
- Battery Testers
- ECG Amplifiers
- Power Automation
- Medical Instrumentation
- Portable Instrumentation

## 3 Description

The INA826S device is a low-cost instrumentation amplifier that offers extremely low power consumption along with shutdown and operates over a very wide single- or dual-supply range. A single external resistor sets any gain from 1 to 1000. The device offers excellent stability over temperature, even at  $G > 1$ , as a result of the low gain drift of only 35 ppm/ $^{\circ}$ C (max).

The INA826S is optimized to provide excellent common-mode rejection ratio of over 100 dB ( $G = 10$ ) over frequencies up to 5 kHz. At  $G = 1$ , the common-mode rejection ratio exceeds 84 dB across the full input common-mode range from the negative supply all the way up to 1 V of the positive supply. Using a rail-to-rail output, the INA826S is well-suited for low voltage operation from a 3-V single supply as well as dual supplies up to  $\pm 18$  V.

Shutdown pins are provided to reduce supply current below 2  $\mu$ A. Additional circuitry protects the inputs against overvoltage of up to  $\pm 40$  V beyond the power supplies by limiting the input currents to less than 8 mA.

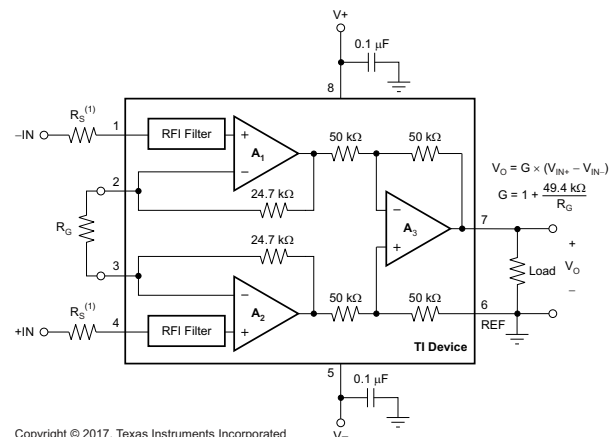
The INA826S is available in a 10-pin, 3-mm  $\times$  3-mm VSON surface-mount package. The INA826S is specified over the  $-40^{\circ}$ C to  $+125^{\circ}$ C temperature range.

### Device Information<sup>(1)</sup>

PART NUMBER	PACKAGE	BODY SIZE (NOM)
INA826S	VSON (10)	3.00 mm $\times$ 3.00 mm

(1) For all available packages, see the orderable addendum at the end of the data sheet.

### INA826S Simplified Internal Schematic



## Table of Contents

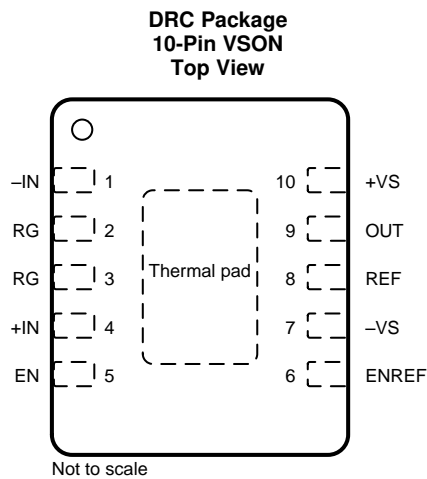
<b>1 Features</b> .....	<b>1</b>	<b>8 Application and Implementation</b> .....	<b>27</b>
<b>2 Applications</b> .....	<b>1</b>	8.1 Application Information.....	27
<b>3 Description</b> .....	<b>1</b>	8.2 Typical Application .....	28
<b>4 Revision History</b> .....	<b>2</b>	<b>9 Power Supply Recommendations</b> .....	<b>30</b>
<b>5 Pin Configuration and Functions</b> .....	<b>3</b>	9.1 Low-Voltage Operation .....	30
<b>6 Specifications</b> .....	<b>4</b>	<b>10 Layout</b> .....	<b>31</b>
6.1 Absolute Maximum Ratings .....	4	10.1 Layout Guidelines .....	31
6.2 ESD Ratings .....	4	10.2 Layout Example .....	31
6.3 Recommended Operating Conditions.....	4	<b>11 Device and Documentation Support</b> .....	<b>32</b>
6.4 Thermal Information .....	4	11.1 Documentation Support .....	32
6.5 Electrical Characteristics.....	5	11.2 Receiving Notification of Documentation Updates	32
6.6 Typical Characteristics.....	8	11.3 Community Resources.....	32
<b>7 Detailed Description</b> .....	<b>19</b>	11.4 Trademarks .....	32
7.1 Overview .....	19	11.5 Electrostatic Discharge Caution.....	32
7.2 Functional Block Diagram .....	19	11.6 Glossary .....	32
7.3 Feature Description.....	20	<b>12 Mechanical, Packaging, and Orderable</b>	<b>32</b>
7.4 Device Functional Modes.....	27	<b>Information</b> .....	<b>32</b>

## 4 Revision History

NOTE: Page numbers for previous revisions may differ from page numbers in the current version.

<b>Changes from Original (May 2017) to Revision A</b>	<b>Page</b>
• Changed output stage offset voltage from 700 $\mu$ V to 1000 $\mu$ V .....	<b>5</b>

## 5 Pin Configuration and Functions



### Pin Functions

NAME	NO.	I/O	DESCRIPTION
EN	5	I	Enable pin; active low with respect to ENREF
ENREF	6	I	Enable pin reference
-IN	1	I	Negative (inverting) input
+IN	4	I	Positive (noninverting) input
OUT	9	O	Output
REF	8	I	Reference input. This pin must be driven by low impedance.
RG	2, 3	—	Gain setting pins. Place a gain resistor between pin 2 and pin 3.
-VS	7	—	Negative supply
+VS	10	—	Positive supply
Thermal pad	Pad	—	Exposed thermal die pad on underside; connect thermal die pad to V-. Soldering the thermal pad improves heat dissipation and provides specified performance.

## 6 Specifications

### 6.1 Absolute Maximum Ratings

 over operating free-air temperature range (unless otherwise noted)<sup>(1)</sup>

		MIN	MAX	UNIT
Supply voltage		-20	20	V
Voltage	Signal input pins	$(-V_S) - 40$	$(+V_S) + 40$	V
	REF pin	-20	+20	
	ENREF pin	$(-V_S) - 0.3$	$(+V_S) + 0.3$	
	EN pin	$(-V_S) - 0.3$	$V_{ENREF} + 0.3$	
Current	Signal input pins	-10	10	mA
	REF pin	-10	10	
	ENREF pin	-1	1	
	EN pin	-1	1	
Output short-circuit <sup>(2)</sup>		Continuous		
Temperature	Operating, $T_A$	-50	150	°C
	Junction, $T_J$		175	
	Storage, $T_{stg}$	-65	150	

- (1) Stresses beyond those listed under *Absolute Maximum Ratings* may cause permanent damage to the device. These are stress ratings only, which do not imply functional operation of the device at these or any other conditions beyond those indicated under *Recommended Operating Conditions*. Exposure to absolute-maximum-rated conditions for extended periods may affect device reliability.
- (2) Short-circuit to  $V_S / 2$ .

### 6.2 ESD Ratings

		VALUE	UNIT
$V_{(ESD)}$	Electrostatic discharge	Human-body model (HBM), per ANSI/ESDA/JEDEC JS-001 <sup>(1)</sup>	±2500
		Charged-device model (CDM), per JEDEC specification JESD22-C101 <sup>(2)</sup>	±1500

- (1) JEDEC document JEP155 states that 500-V HBM allows safe manufacturing with a standard ESD control process.
- (2) JEDEC document JEP157 states that 250-V CDM allows safe manufacturing with a standard ESD control process.

### 6.3 Recommended Operating Conditions

over operating free-air temperature range (unless otherwise noted)

		MIN	NOM	MAX	UNIT
Supply voltage	Single-supply	3		36	V
	Dual-supply	±1.5		±18	
Specified temperature		-40		125	°C

### 6.4 Thermal Information

THERMAL METRIC <sup>(1)</sup>		INA826S	UNIT
		VSON (DRC)	
		10 PINS	
$R_{\theta JA}$	Junction-to-ambient thermal resistance	51.9	°C/W
$R_{\theta JC(top)}$	Junction-to-case (top) thermal resistance	58.2	°C/W
$R_{\theta JB}$	Junction-to-board thermal resistance	25.8	°C/W
$\Psi_{JT}$	Junction-to-top characterization parameter	2.0	°C/W
$\Psi_{JB}$	Junction-to-board characterization parameter	25.8	°C/W
$R_{\theta JC(bot)}$	Junction-to-case (bottom) thermal resistance	8.6	°C/W

- (1) For more information about traditional and new thermal metrics, see the [Semiconductor and IC Package Thermal Metrics](#) application report.

## 6.5 Electrical Characteristics

at  $T_A = 25^\circ\text{C}$ ,  $V_S = \pm 15\text{ V}$ ,  $R_L = 10\text{ k}\Omega$ ,  $V_{\text{REF}} = 0\text{ V}$ , and  $G = 1$  (unless otherwise noted)

PARAMETER		TEST CONDITIONS	MIN	TYP	MAX	UNIT
<b>INPUT</b>						
$V_{\text{OSI}}$	Input stage offset voltage <sup>(1)</sup>	RTI		40	150	$\mu\text{V}$
		vs temperature, $T_A = -40^\circ\text{C}$ to $+125^\circ\text{C}$		0.4	2	$\mu\text{V}/^\circ\text{C}$
$V_{\text{OSO}}$	Output stage offset voltage <sup>(1)</sup>	RTI		200	1000	$\mu\text{V}$
		vs temperature, $T_A = -40^\circ\text{C}$ to $+125^\circ\text{C}$		2	5	$\mu\text{V}/^\circ\text{C}$
PSRR	Power-supply rejection ratio	$G = 1$ , RTI	90	124		dB
		$G = 10$ , RTI	100	130		
		$G = 100$ , RTI	110	140		
		$G = 1000$ , RTI	120	140		
$z_{\text{id}}$	Differential impedance		20    1			$\text{G}\Omega$    pF
$z_{\text{ic}}$	Common-mode impedance		10    5			$\text{G}\Omega$    pF
	RFI filter, -3-dB frequency		20			MHz
$V_{\text{CM}}$	Operating input range <sup>(2)</sup>	$V_S = \pm 3\text{ V}$ to $\pm 18\text{ V}$ , $T_A = -40^\circ\text{C}$ to $+125^\circ\text{C}$	V-		$(V+) - 1$	V
			See Figure 12 to Figure 19			
	Input overvoltage range	$T_A = -40^\circ\text{C}$ to $125^\circ\text{C}$			$\pm 40$	V
CMRR	Common-mode rejection ratio	At dc to 60 Hz, RTI	$G = 1$ , $V_{\text{CM}} = (V-) \text{ to } (V+) - 1\text{ V}$	82	95	dB
			$G = 10$ , $V_{\text{CM}} = (V-) \text{ to } (V+) - 1\text{ V}$	104	115	
			$G = 100$ , $V_{\text{CM}} = (V-) \text{ to } (V+) - 1\text{ V}$	120	130	
			$G = 1000$ , $V_{\text{CM}} = (V-) \text{ to } (V+) - 1\text{ V}$	120	130	
		At 5 kHz, RTI	$G = 1$ , $V_{\text{CM}} = (V-) \text{ to } (V+) - 1\text{ V}$ , $T_A = -40^\circ\text{C}$ to $+125^\circ\text{C}$	80		
			$G = 1$ , $V_{\text{CM}} = (V-) \text{ to } (V+) - 1\text{ V}$	84		
			$G = 10$ , $V_{\text{CM}} = (V-) \text{ to } (V+) - 1\text{ V}$	100		
			$G = 100$ , $V_{\text{CM}} = (V-) \text{ to } (V+) - 1\text{ V}$	105		
	$G = 1000$ , $V_{\text{CM}} = (V-) \text{ to } (V+) - 1\text{ V}$	105				
<b>BIAS CURRENT</b>						
$I_B$	Input bias current	$V_{\text{CM}} = V_S / 2$		35	65	nA
		$T_A = -40^\circ\text{C}$ to $+125^\circ\text{C}$			95	
$I_{\text{OS}}$	Input offset current	$V_{\text{CM}} = V_S / 2$		0.7	5	nA
		$T_A = -40^\circ\text{C}$ to $+125^\circ\text{C}$			10	
<b>NOISE VOLTAGE</b>						
$e_{\text{NI}}$	Input stage voltage noise <sup>(3)</sup>	$f = 1\text{ kHz}$ , $G = 100$ , $R_S = 0\ \Omega$		18		$\text{nV}/\sqrt{\text{Hz}}$
		$f_B = 0.1\text{ Hz}$ to $10\text{ Hz}$ , $G = 100$ , $R_S = 0\ \Omega$		0.52		$\mu\text{V}_{\text{PP}}$
$e_{\text{NO}}$	Output stage voltage noise <sup>(3)</sup>	$f = 1\text{ kHz}$ , $G = 1$ , $R_S = 0\ \Omega$		110		$\text{nV}/\sqrt{\text{Hz}}$
		$f_B = 0.1\text{ Hz}$ to $10\text{ Hz}$ , $G = 1$ , $R_S = 0\ \Omega$		3.3		$\mu\text{V}_{\text{PP}}$
$I_n$	Noise current	$f = 1\text{ kHz}$		100		$\text{fA}/\sqrt{\text{Hz}}$
		$f_B = 0.1\text{ Hz}$ to $10\text{ Hz}$		5		$\text{pA}_{\text{PP}}$

(1) Total offset, referred-to-input (RTI):  $V_{\text{OS}} = (V_{\text{OSI}}) + (V_{\text{OSO}} / G)$ .

(2) Input voltage range of the INA826S input stage. The input range depends on the common-mode voltage, differential voltage, gain, and reference voltage.

(3) Total RTI voltage noise is equal to:
$$\sqrt{(e_{\text{NI}})^2 + \left(\frac{e_{\text{NO}}}{G}\right)^2}$$

**Electrical Characteristics (continued)**

 at  $T_A = 25^\circ\text{C}$ ,  $V_S = \pm 15\text{ V}$ ,  $R_L = 10\text{ k}\Omega$ ,  $V_{REF} = 0\text{ V}$ , and  $G = 1$  (unless otherwise noted)

PARAMETER		TEST CONDITIONS	MIN	TYP	MAX	UNIT
<b>GAIN</b>						
G	Gain equation		$1 + (49.4\text{ k}\Omega / R_G)$			V/V
G	Range of gain		1		1000	V/V
G <sub>E</sub>	Gain error	G = 1, V <sub>O</sub> = ±10 V		±0.003%	±0.020%	
		G = 10, V <sub>O</sub> = ±10 V		±0.03%	±0.15%	
		G = 100, V <sub>O</sub> = ±10 V		±0.04%	±0.15%	
		G = 1000, V <sub>O</sub> = ±10 V		±0.04%	±0.15%	
	Gain vs temperature <sup>(4)</sup>	G = 1, T <sub>A</sub> = –40°C to +125°C		±0.1	±1	ppm/°C
		G > 1, T <sub>A</sub> = –40°C to +125°C		±10	±35	
	Gain nonlinearity	G = 1 to 100, V <sub>O</sub> = –10 V to 10 V		1	5	ppm
		G = 1000, V <sub>O</sub> = –10 V to 10 V		5	20	
<b>OUTPUT</b>						
	Voltage swing	R <sub>L</sub> = 10 kΩ	(V–) + 0.1		(V+) – 0.15	V
	Load capacitance stability			1000		pF
Z <sub>O</sub>	Open-loop output impedance		See <a href="#">Figure 59</a>			
I <sub>SC</sub>	Short-circuit current	Continuous to V <sub>S</sub> / 2		±16		mA
<b>FREQUENCY RESPONSE</b>						
BW	Bandwidth, –3 dB	G = 1		1		MHz
		G = 10		500		kHz
		G = 100		60		
		G = 1000		6		
SR	Slew rate	G = 1, V <sub>STEP</sub> = 10 V		1		V/μs
		G = 100, V <sub>STEP</sub> = 10 V		1		
t <sub>S</sub>	Settling time	0.01%	G = 1, V <sub>STEP</sub> = 10 V		12	μs
			G = 10, V <sub>STEP</sub> = 10 V		12	
			G = 100, V <sub>STEP</sub> = 10 V		24	
			G = 1000, V <sub>STEP</sub> = 10 V		224	
		0.001%	G = 1, V <sub>STEP</sub> = 10 V		14	
			G = 10, V <sub>STEP</sub> = 10 V		14	
			G = 100, V <sub>STEP</sub> = 10 V		31	
			G = 1000, V <sub>STEP</sub> = 10 V		278	
<b>REFERENCE INPUT</b>						
R <sub>IN</sub>	Input impedance			100		kΩ
	Voltage range		(V–)		(V+)	V
	Gain to output			1		V/V
	Reference gain error			0.01%		
<b>ENABLE INPUT</b>						
	Enable threshold voltage	Referenced to ENREF pin		–0.75		V
		T <sub>A</sub> = –40°C to +125°C			–1.0	
	Disable threshold voltage	Referenced to ENREF pin		–0.7		V
		T <sub>A</sub> = –40°C to +125°C	–0.40			
	EN pin input current	V <sub>ENREF</sub> = 1.5 V, V <sub>EN</sub> = 0 V		3		μA
	ENREF pin input current	V <sub>ENREF</sub> = 1.5 V, V <sub>EN</sub> = 0 V		–3		μA
	EN pin voltage range		V–		V <sub>ENREF</sub>	V
	ENREF voltage range		(V–) + 1.5 V		V+	V
	Enable delay			100		μs

 (4) The values specified for G > 1 do not include the effects of the external gain-setting resistor, R<sub>G</sub>.

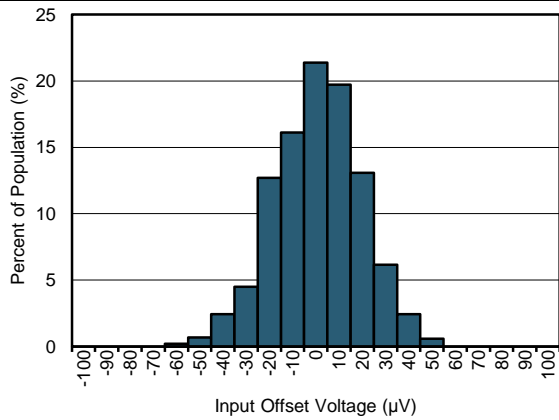
**Electrical Characteristics (continued)**

 at  $T_A = 25^\circ\text{C}$ ,  $V_S = \pm 15\text{ V}$ ,  $R_L = 10\text{ k}\Omega$ ,  $V_{\text{REF}} = 0\text{ V}$ , and  $G = 1$  (unless otherwise noted)

PARAMETER		TEST CONDITIONS	MIN	TYP	MAX	UNIT
<b>POWER SUPPLY</b>						
$V_S$	Power-supply voltage	Single	3		36	V
		Dual	$\pm 1.5$		$\pm 18$	
$I_Q$	Quiescent current	$V_{\text{IN}} = 0\text{ V}$		200	250	$\mu\text{A}$
		$T_A = -40^\circ\text{C}$ to $+125^\circ\text{C}$			320	
$I_{\text{QSD}}$	Shutdown current	$V_S = 3\text{ V}$ to $36\text{ V}$ , $V_{\text{IN}} = 0\text{ V}$		2	5	$\mu\text{A}$
		$T_A = -40^\circ\text{C}$ to $+125^\circ\text{C}$			6	
<b>TEMPERATURE RANGE</b>						
	Specified		-40		125	$^\circ\text{C}$
	Operating		-50		150	$^\circ\text{C}$

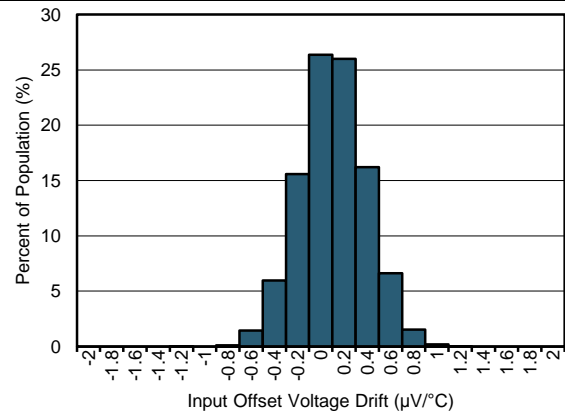
## 6.6 Typical Characteristics

at  $T_A = 25^\circ\text{C}$ ,  $V_S = \pm 15\text{ V}$ ,  $R_L = 10\text{ k}\Omega$ ,  $V_{REF} = 0\text{ V}$ , and  $G = 1$  (unless otherwise noted)



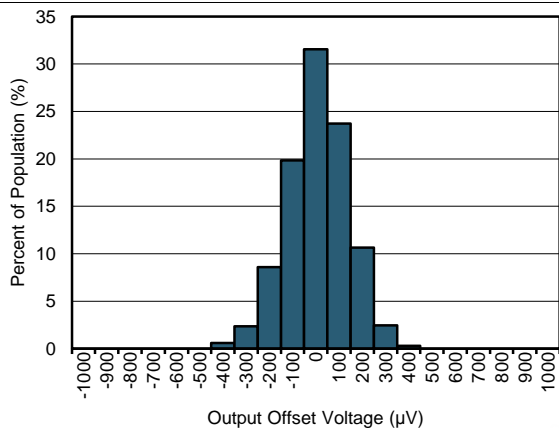
1024 units

Figure 1. Typical Distribution of Input Offset Voltage



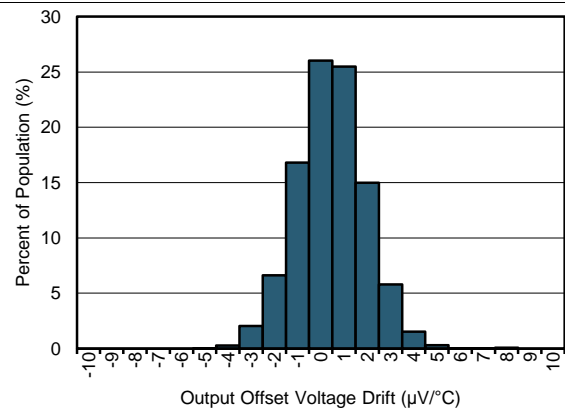
5977 units

Figure 2. Typical Distribution of Input Offset Voltage Drift



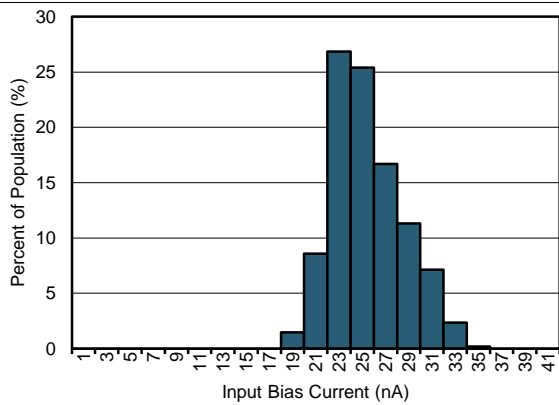
1024 units

Figure 3. Typical Distribution of Output Offset Voltage



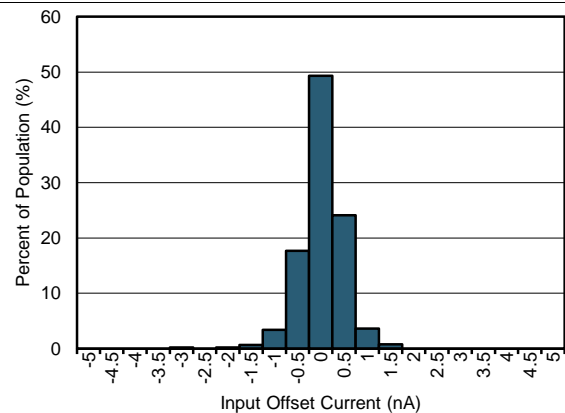
5977 units

Figure 4. Typical Distribution of Output Offset Voltage Drift



1024 units

Figure 5. Typical Distribution of Input Bias Current



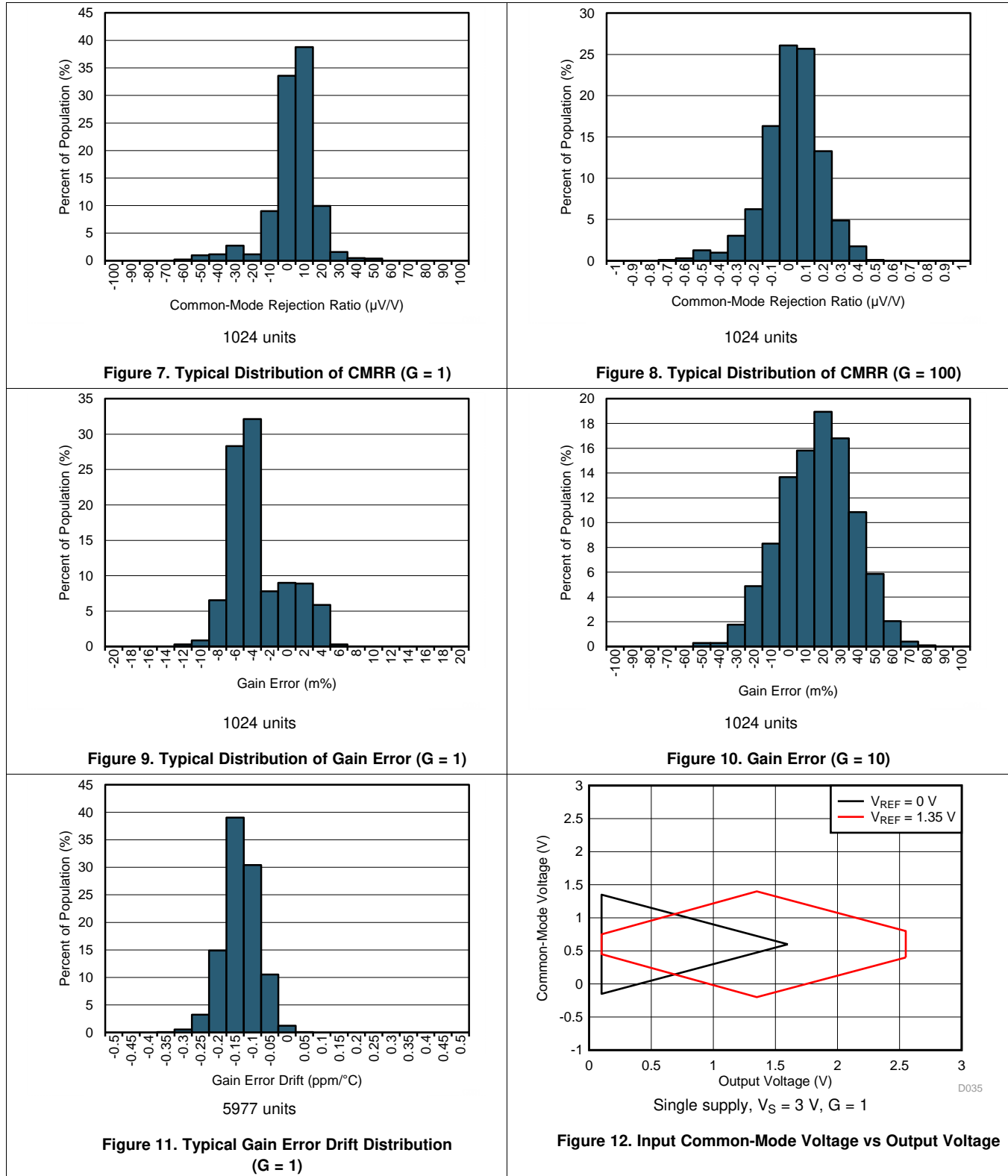
1024 units

Figure 6. Typical Distribution of Input Offset Current



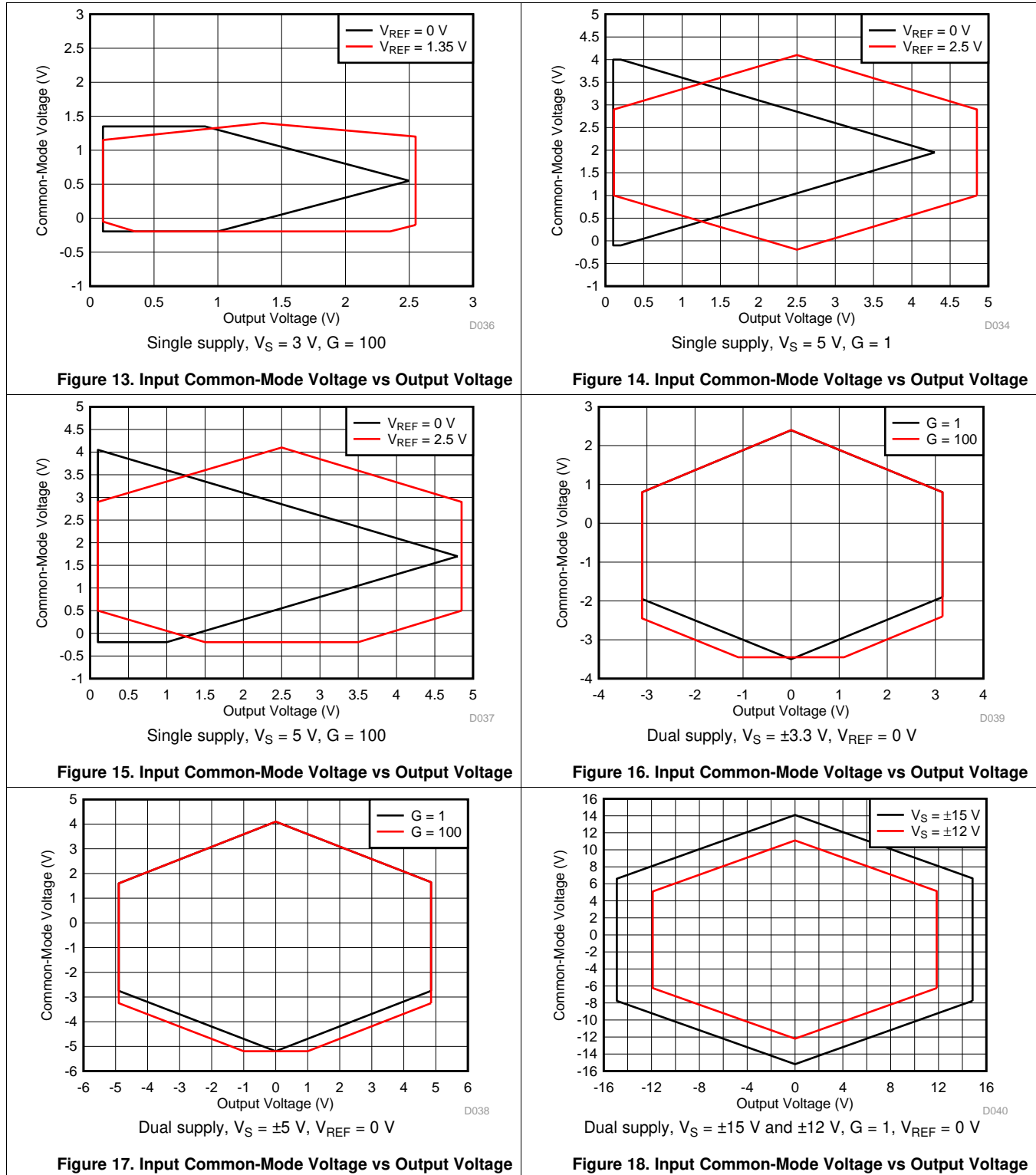
Typical Characteristics (continued)

at  $T_A = 25^\circ\text{C}$ ,  $V_S = \pm 15\text{ V}$ ,  $R_L = 10\text{ k}\Omega$ ,  $V_{REF} = 0\text{ V}$ , and  $G = 1$  (unless otherwise noted)



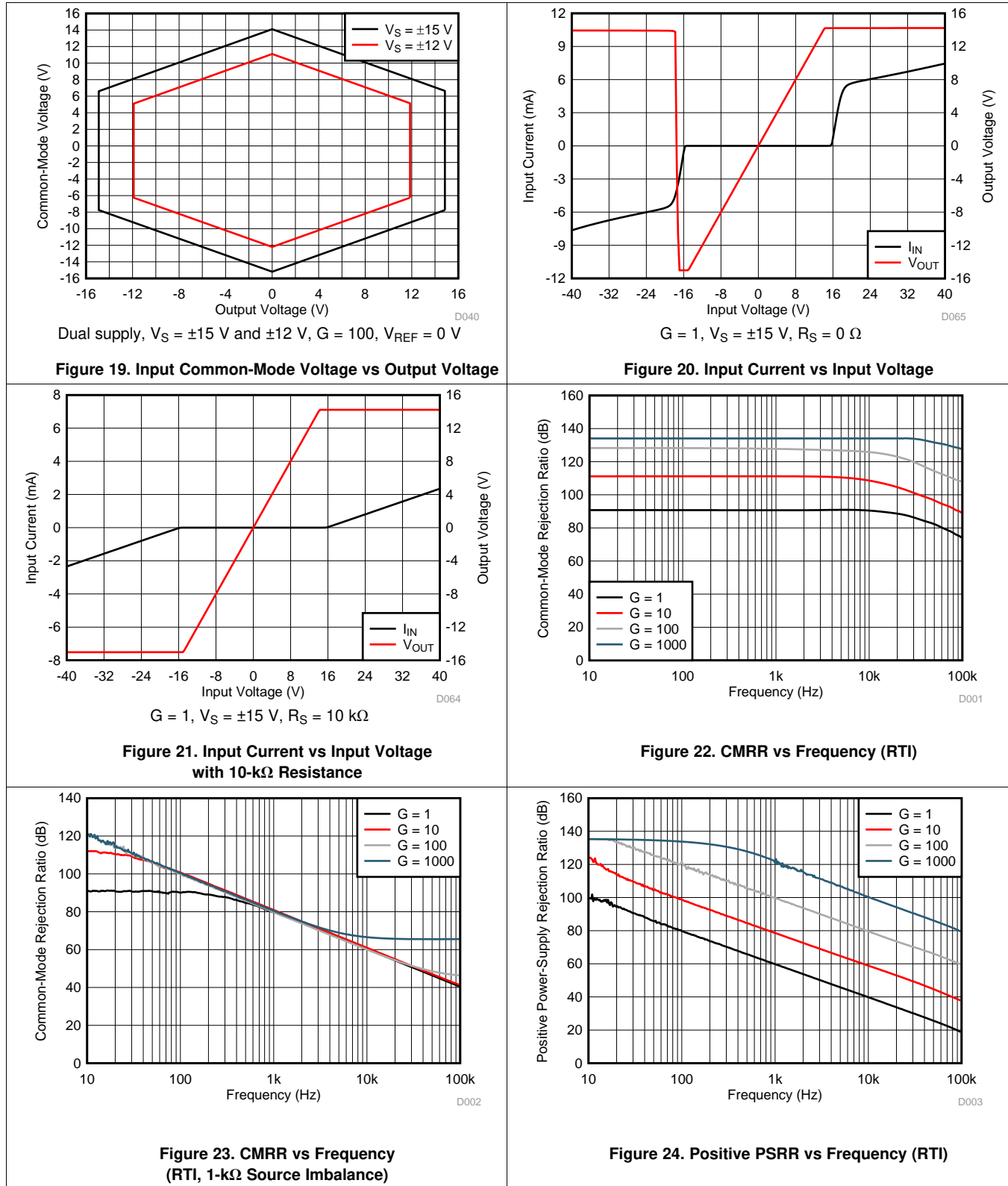
### Typical Characteristics (continued)

at  $T_A = 25^\circ\text{C}$ ,  $V_S = \pm 15\text{ V}$ ,  $R_L = 10\text{ k}\Omega$ ,  $V_{REF} = 0\text{ V}$ , and  $G = 1$  (unless otherwise noted)



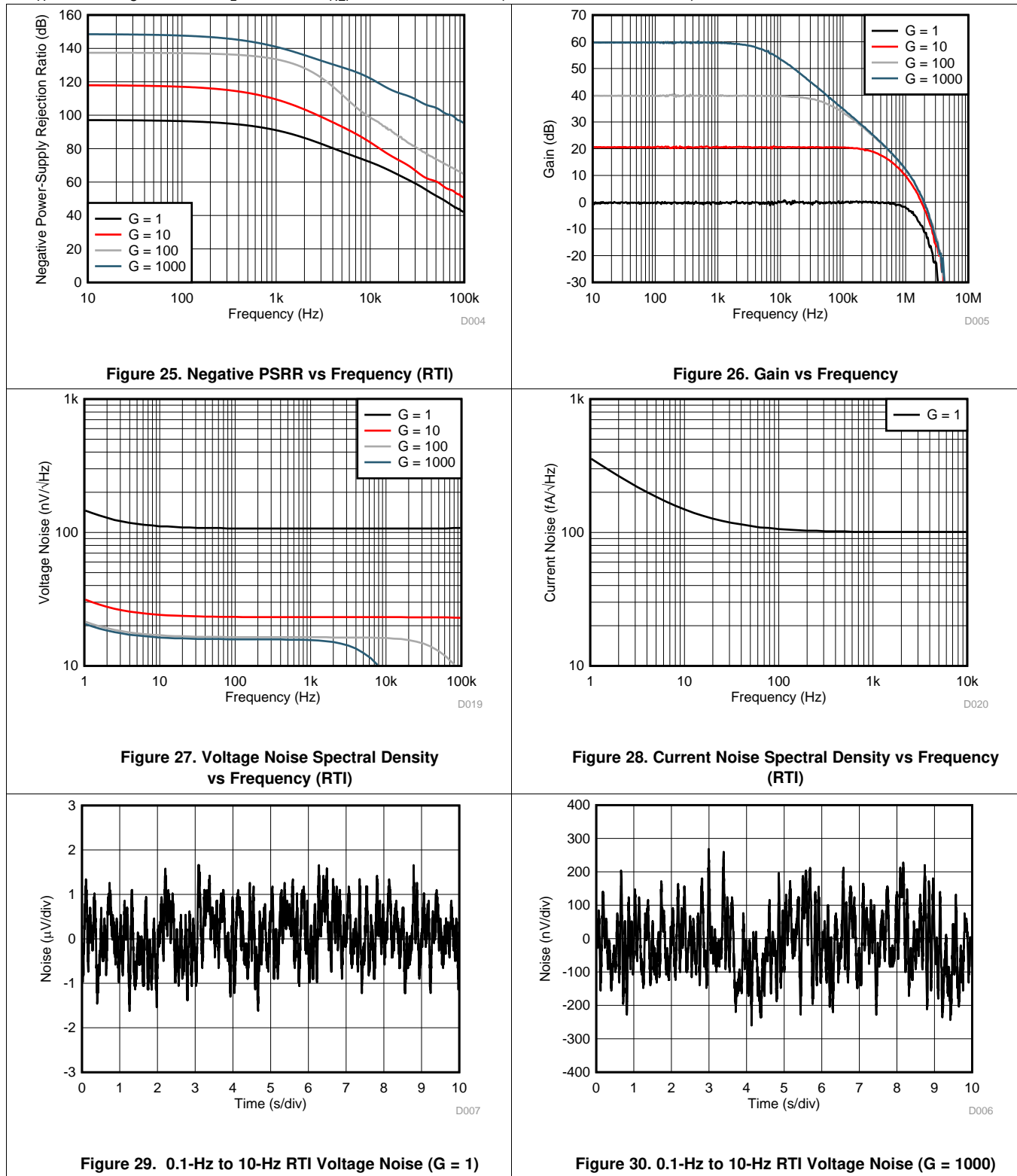
Typical Characteristics (continued)

at  $T_A = 25^\circ\text{C}$ ,  $V_S = \pm 15\text{ V}$ ,  $R_L = 10\text{ k}\Omega$ ,  $V_{REF} = 0\text{ V}$ , and  $G = 1$  (unless otherwise noted)



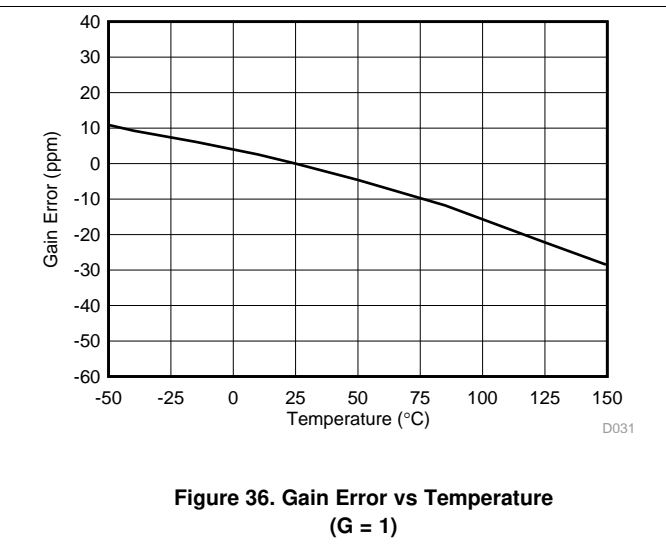
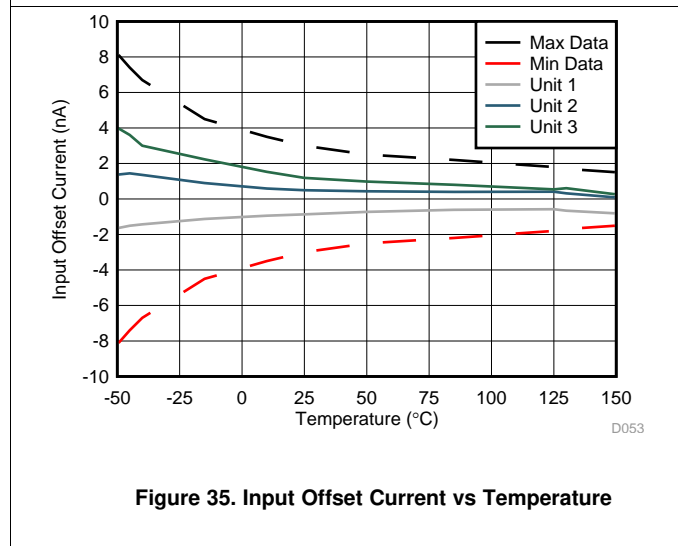
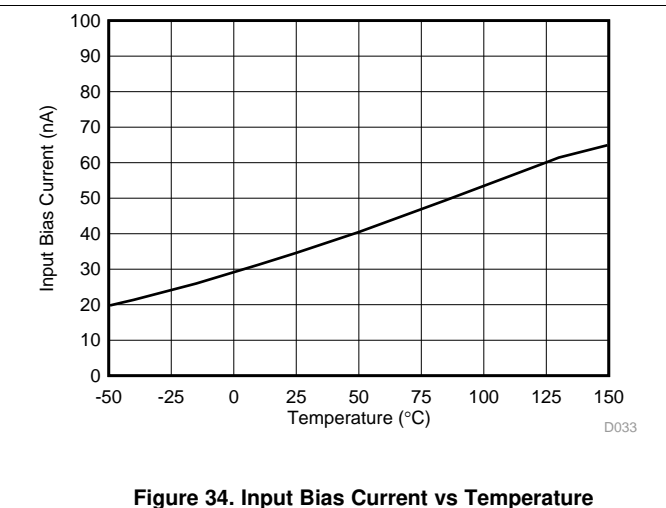
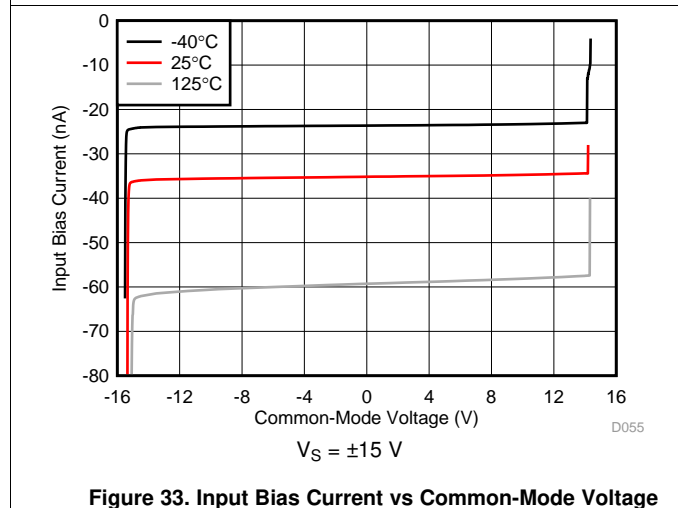
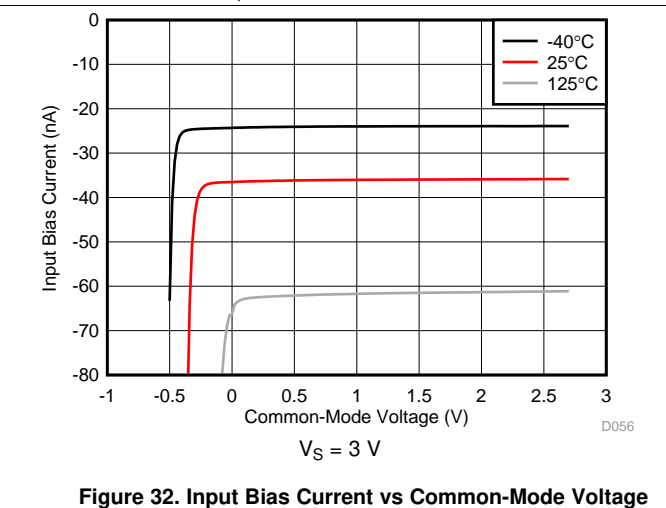
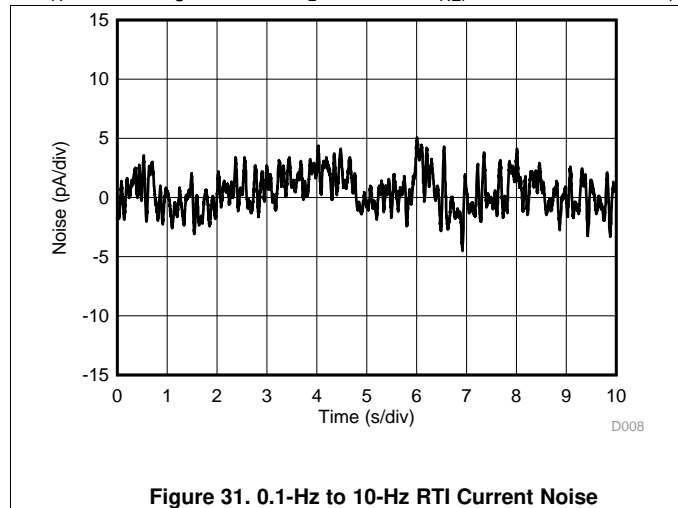
Typical Characteristics (continued)

at  $T_A = 25^\circ\text{C}$ ,  $V_S = \pm 15\text{ V}$ ,  $R_L = 10\text{ k}\Omega$ ,  $V_{REF} = 0\text{ V}$ , and  $G = 1$  (unless otherwise noted)



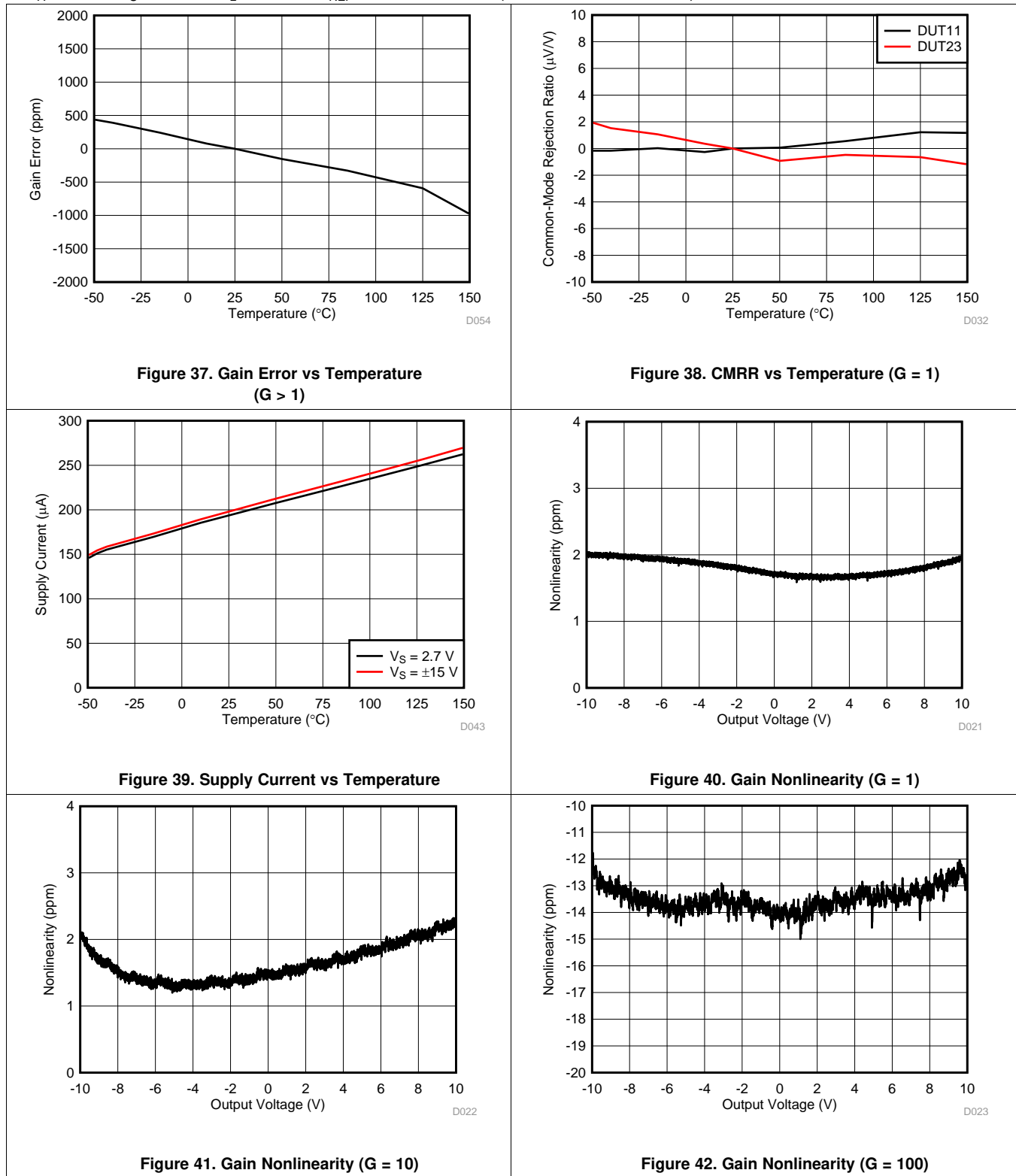
Typical Characteristics (continued)

at  $T_A = 25^\circ\text{C}$ ,  $V_S = \pm 15\text{ V}$ ,  $R_L = 10\text{ k}\Omega$ ,  $V_{REF} = 0\text{ V}$ , and  $G = 1$  (unless otherwise noted)



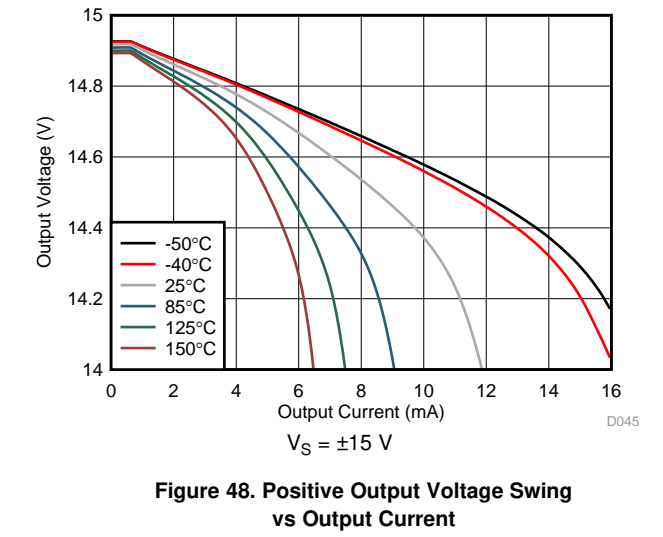
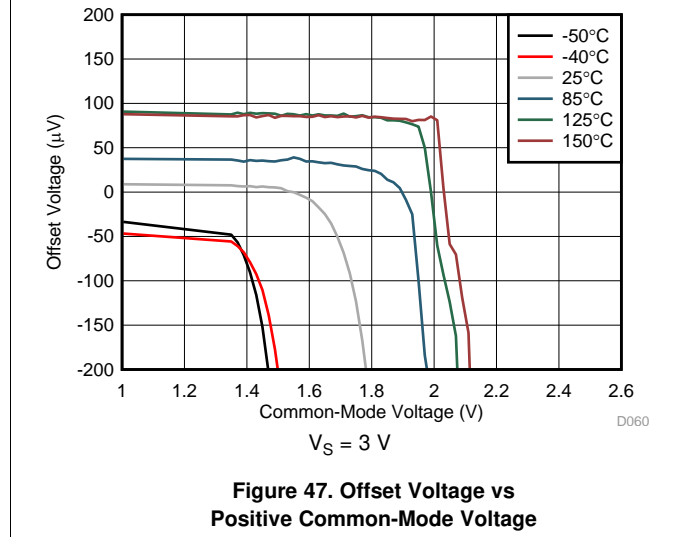
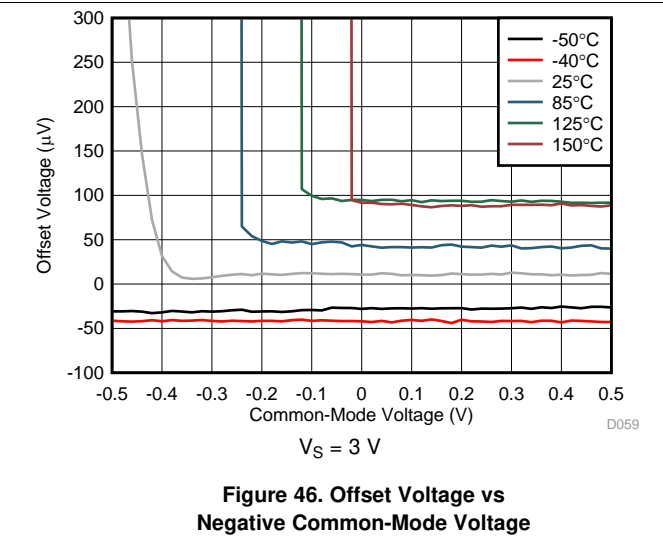
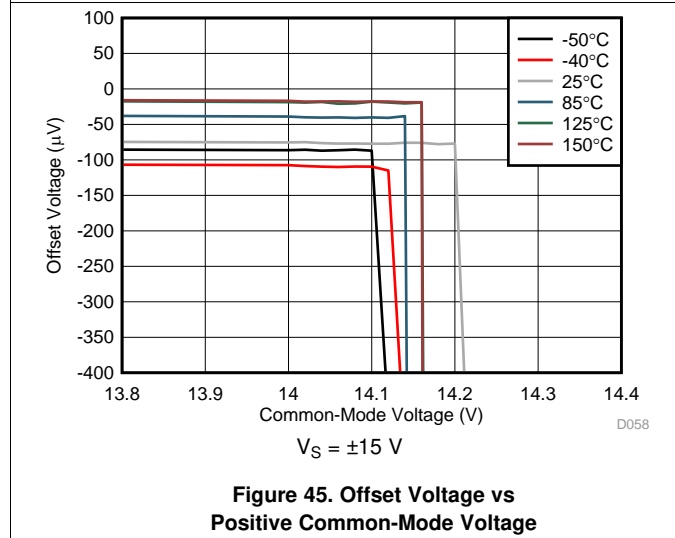
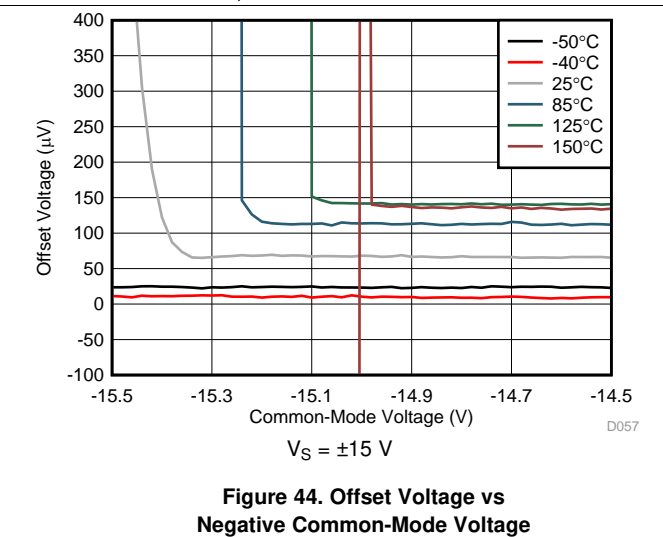
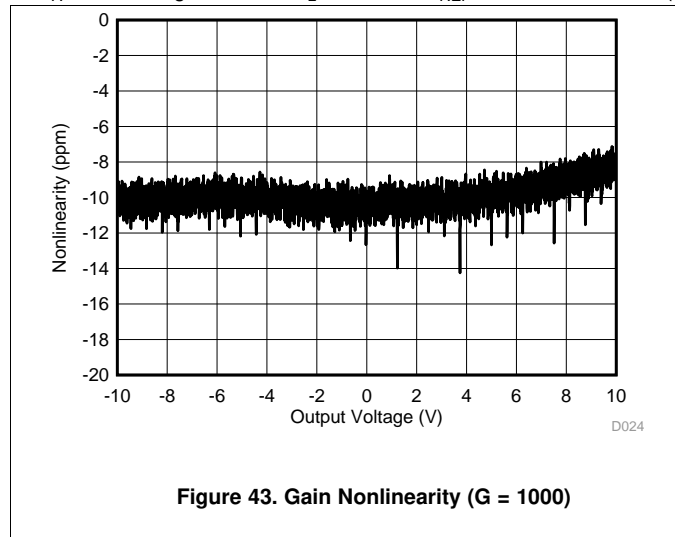
### Typical Characteristics (continued)

at  $T_A = 25^\circ\text{C}$ ,  $V_S = \pm 15\text{ V}$ ,  $R_L = 10\text{ k}\Omega$ ,  $V_{REF} = 0\text{ V}$ , and  $G = 1$  (unless otherwise noted)



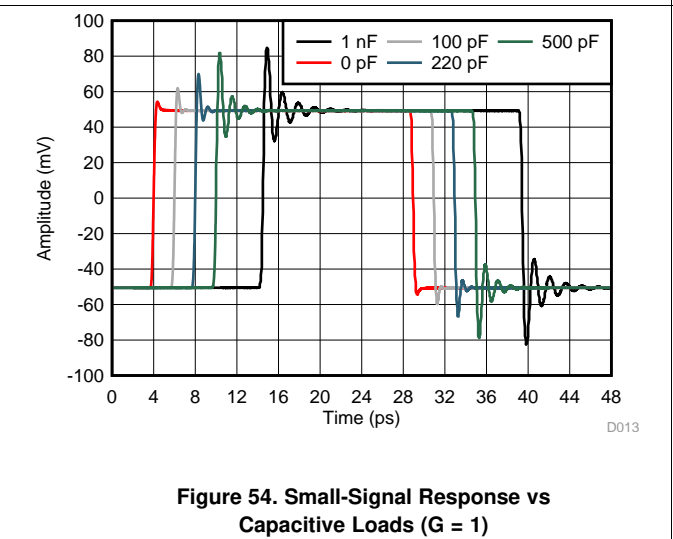
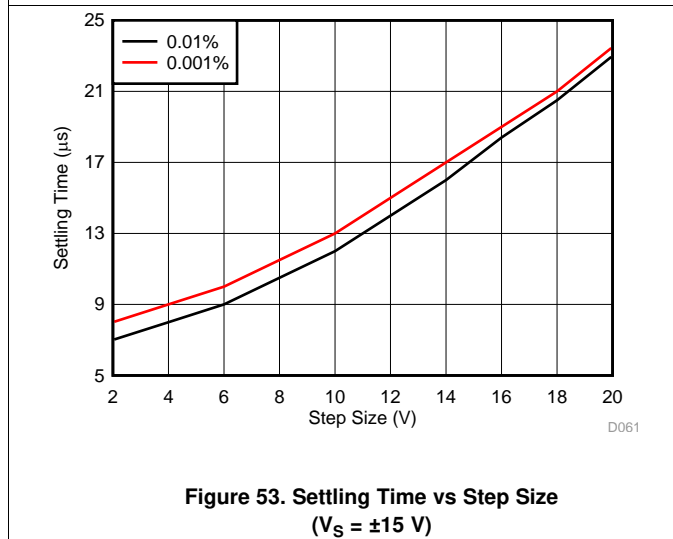
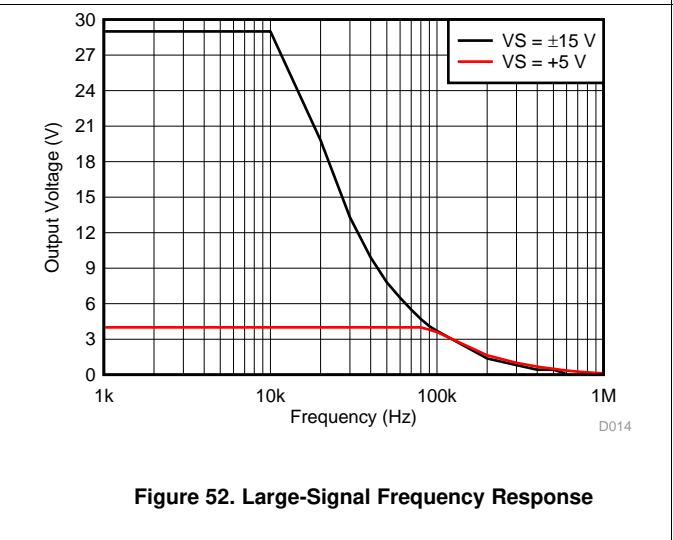
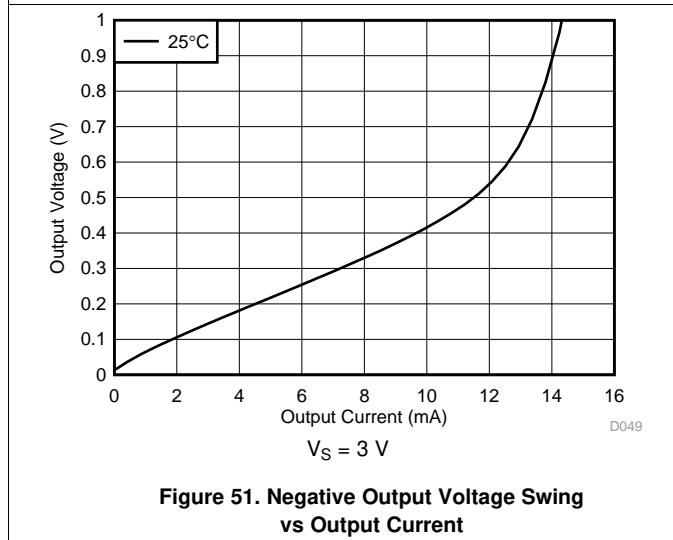
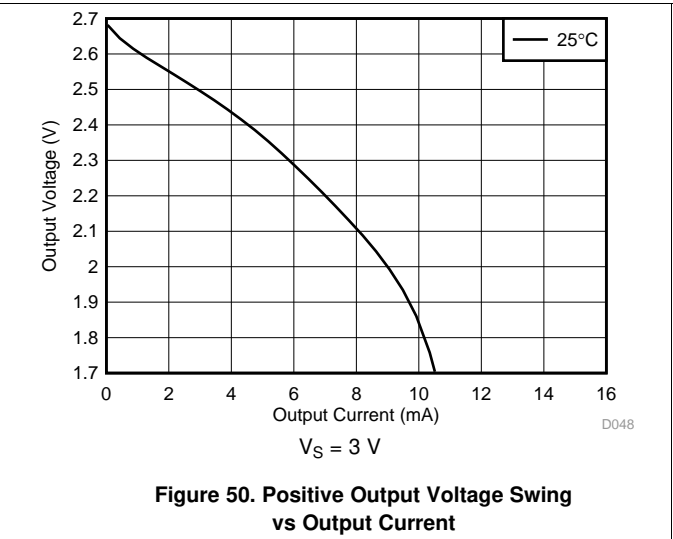
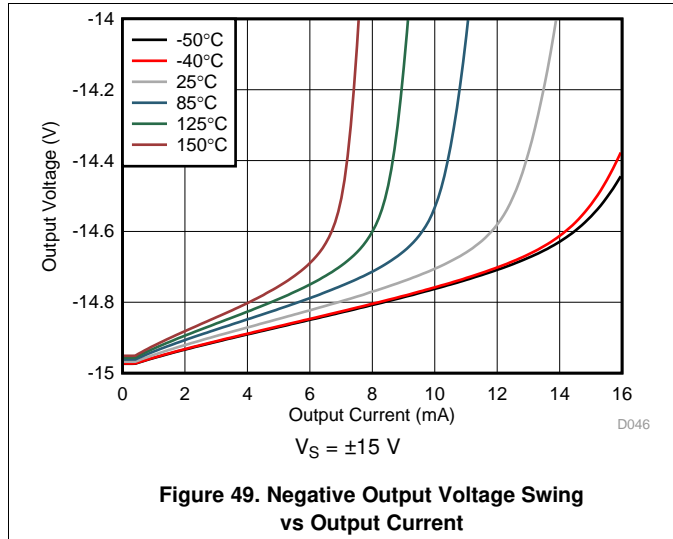
### Typical Characteristics (continued)

at  $T_A = 25^\circ\text{C}$ ,  $V_S = \pm 15\text{ V}$ ,  $R_L = 10\text{ k}\Omega$ ,  $V_{REF} = 0\text{ V}$ , and  $G = 1$  (unless otherwise noted)



Typical Characteristics (continued)

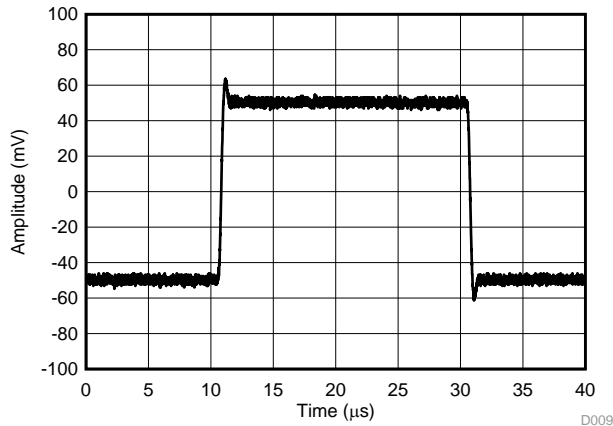
at  $T_A = 25^\circ\text{C}$ ,  $V_S = \pm 15\text{ V}$ ,  $R_L = 10\text{ k}\Omega$ ,  $V_{REF} = 0\text{ V}$ , and  $G = 1$  (unless otherwise noted)



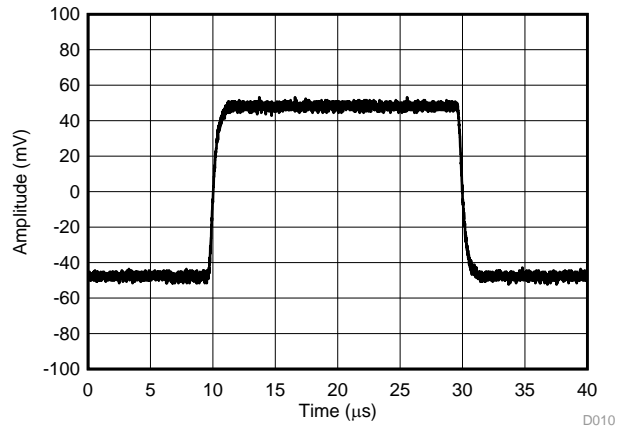


Typical Characteristics (continued)

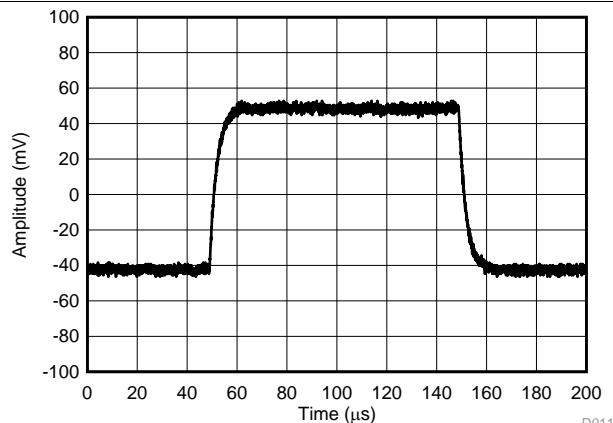
at  $T_A = 25^\circ\text{C}$ ,  $V_S = \pm 15\text{ V}$ ,  $R_L = 10\text{ k}\Omega$ ,  $V_{REF} = 0\text{ V}$ , and  $G = 1$  (unless otherwise noted)



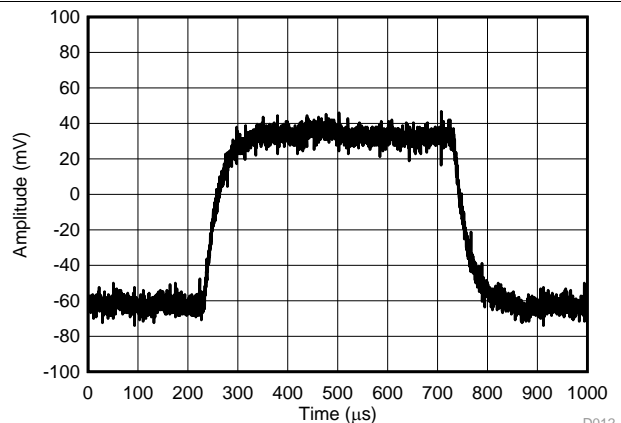
$G = 1, R_L = 1\text{ k}\Omega, C_L = 100\text{ pF}$   
**Figure 55. Small-Signal Response**



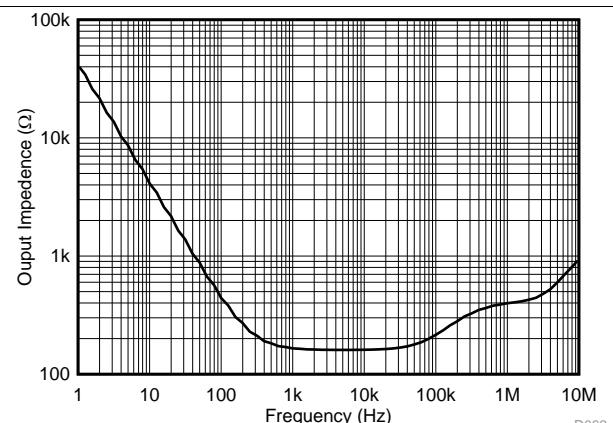
$G = 10, R_L = 10\text{ k}\Omega, C_L = 100\text{ pF}$   
**Figure 56. Small-Signal Response**



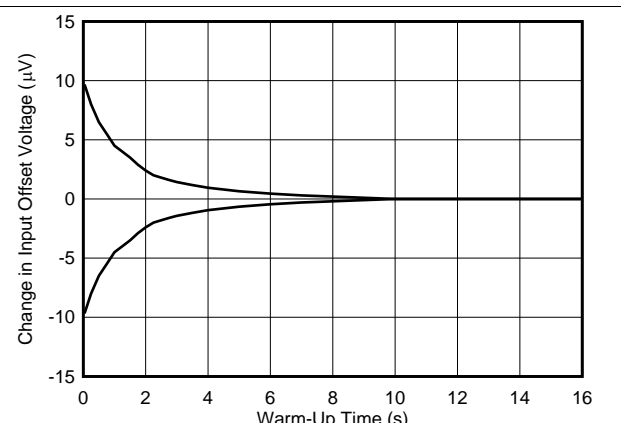
$G = 100, R_L = 10\text{ k}\Omega, C_L = 100\text{ pF}$   
**Figure 57. Small-Signal Response**



$G = 1000, R_L = 10\text{ k}\Omega, C_L = 100\text{ pF}$   
**Figure 58. Small-Signal Response**

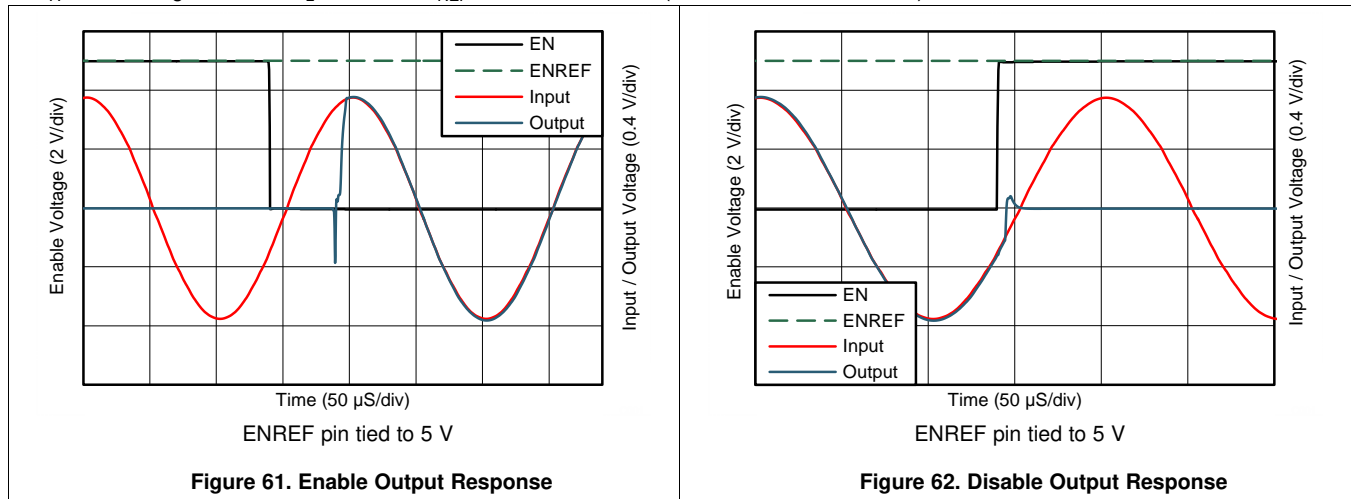


**Figure 59. Open-Loop Output Impedance vs Frequency**



**Figure 60. Change in Input Offset Voltage vs Warm-Up Time**

**Typical Characteristics (continued)**

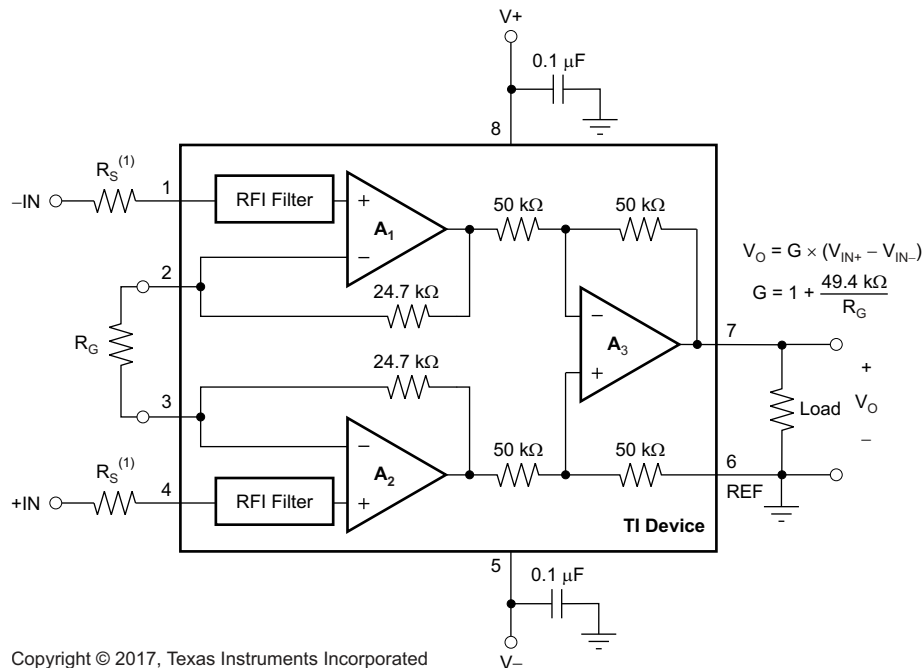
 at  $T_A = 25^\circ\text{C}$ ,  $V_S = \pm 15\text{ V}$ ,  $R_L = 10\text{ k}\Omega$ ,  $V_{REF} = 0\text{ V}$ , and  $G = 1$  (unless otherwise noted)


## 7 Detailed Description

### 7.1 Overview

A simplified schematic of the INA826S is shown in as well as the basic connections required for proper functionality. The INA826S consists of a 4-resistor difference amplifier, composed of amplifier A3 and 50-kΩ resistors, as well as buffer amplifiers A1 and A2. The gain of the circuit is set by a single external resistor placed across pins 2 and 3. Further information on the internal topology and setting the gain can be found in the [Feature Description](#) section. High-precision thin-film resistors integrated on-chip allow for excellent rejection of common-mode interference signals and high gain accuracy. The INA826S also integrates radio frequency interference (RFI) filters on the signal inputs to provide improved performance in the presence of high-frequency interference.

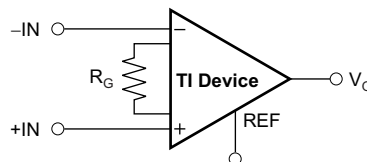
### 7.2 Functional Block Diagram



Copyright © 2017, Texas Instruments Incorporated

- (1) This resistor is optional if the input voltage stays above  $[(V-) - 2 \text{ V}]$  or the signal source current drive capability is limited to less than 3.5 mA. See the [Input Protection](#) section for more details.

Figure 63. Simplified Block Diagram



Copyright © 2017, Texas Instruments Incorporated

Figure 64. INA826S Basic Connections

### 7.3 Feature Description

#### 7.3.1 Inside the INA826S

See the *Functional Block Diagram* section for a simplified representation of the INA826S. A more detailed diagram (shown in Figure 65) provides additional details of the INA826S operation.

Each input is protected by two field-effect transistors (FETs) that provide a low series resistance under normal signal conditions, and preserve excellent noise performance. When excessive voltage is applied, these transistors limit input current to approximately 8 mA.

The differential input voltage is buffered by Q<sub>1</sub> and Q<sub>2</sub> and is impressed across R<sub>G</sub>, causing a signal current to flow through R<sub>G</sub>, R<sub>1</sub>, and R<sub>2</sub>. The output difference amplifier, A<sub>3</sub>, removes the common-mode component of the input signal and refers the output signal to the REF pin.

The equations shown in Figure 65 describe the output voltages of A<sub>1</sub> and A<sub>2</sub>. The V<sub>BE</sub> and voltage drop across R<sub>1</sub> and R<sub>2</sub> produce output voltages on A<sub>1</sub> and A<sub>2</sub> that are approximately 0.8 V higher than the input voltages.

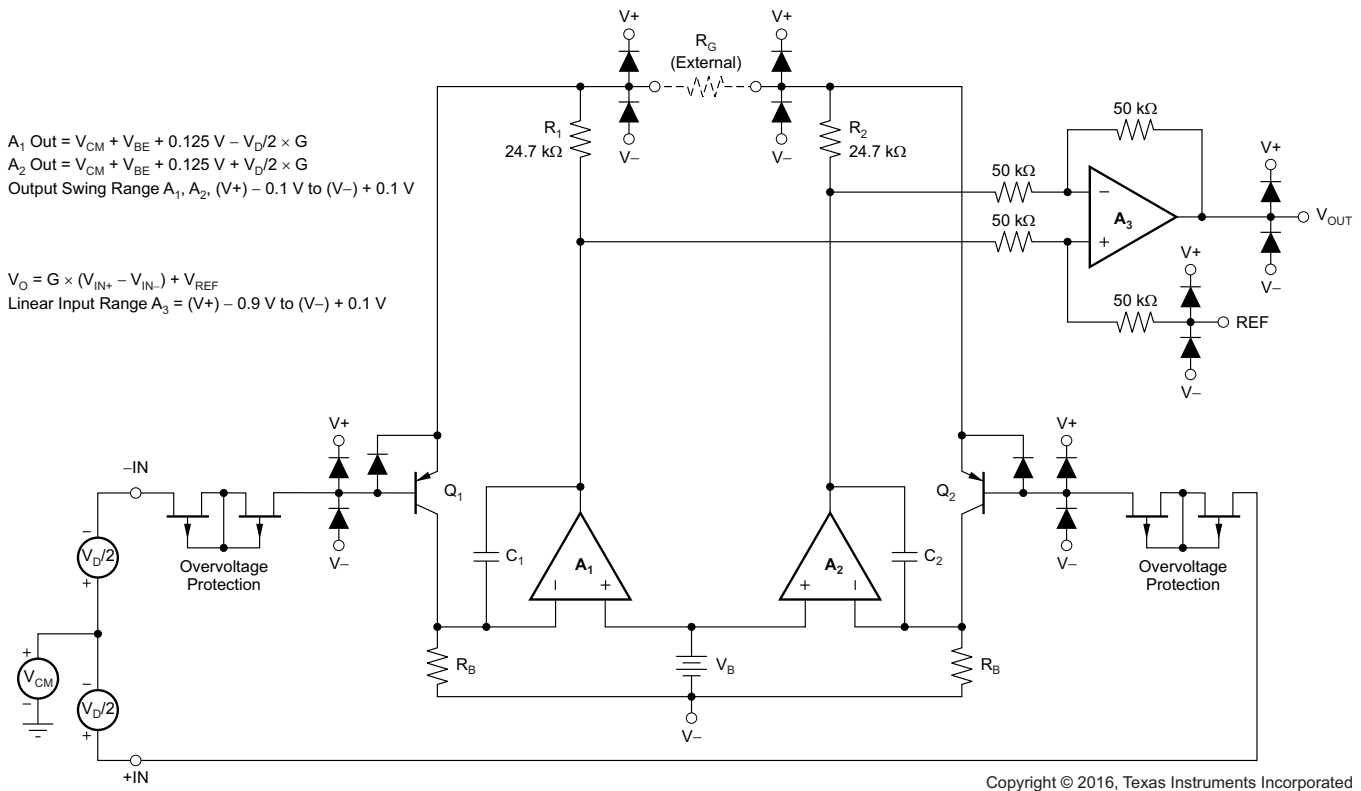


Figure 65. INA826S Simplified Circuit Diagram

## Feature Description (continued)

### 7.3.2 Setting the Gain

Gain of the INA826S is set by a single external resistor,  $R_G$ , connected between pins 2 and 3. Use [Equation 1](#) to select the value of  $R_G$ :

$$G = 1 + \left( \frac{49.4 \text{ k}\Omega}{R_G} \right) \quad (1)$$

[Table 1](#) lists several commonly-used gains and resistor values. The 49.4-k $\Omega$  term in [Equation 1](#) comes from the sum of the two internal 24.7-k $\Omega$  feedback resistors. These on-chip resistors are laser-trimmed to accurate absolute values. The accuracy and temperature coefficients of these resistors are included in the gain accuracy and drift specifications of the INA826S.

**Table 1. Commonly-Used Gains and Resistor Values**

DESIRED GAIN (V/V)	$R_G$ ( $\Omega$ )	NEAREST 1% $R_G$ ( $\Omega$ )
1	—	—
2	49.4 k	49.9 k
5	12.35 k	12.4 k
10	5.489 k	5.49 k
20	2.600 k	2.61 k
50	1.008 k	1 k
100	499	499
200	248	249
500	99	100
1000	49.5	49.9

#### 7.3.2.1 Gain Drift

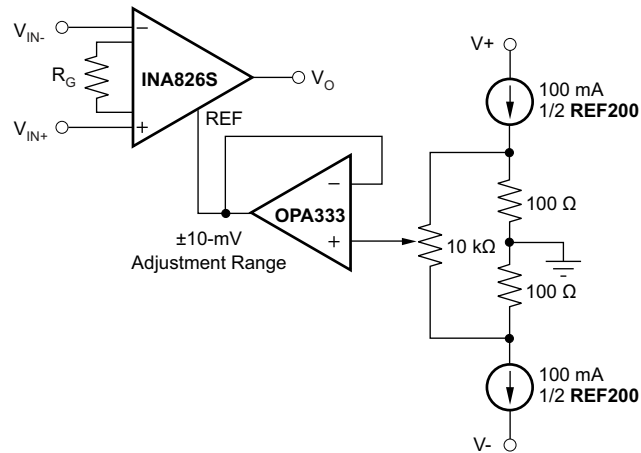
The stability and temperature drift of the external gain setting resistor,  $R_G$ , also affects gain. The contribution of  $R_G$  to gain accuracy and drift can be directly inferred from the gain of [Equation 1](#).

The best gain drift of 1 ppm/ $^{\circ}$ C can be achieved when the INA826S uses  $G = 1$  without  $R_G$  connected. In this case, the gain drift is limited only by the slight mismatch of the temperature coefficient of the integrated 50-k $\Omega$  resistors in the differential amplifier ( $A_3$ ). At  $G$  greater than 1, the gain drift increases as a result of the individual drift of the 24.7-k $\Omega$  resistors in the feedback of  $A_1$  and  $A_2$ , relative to the drift of the external gain resistor  $R_G$ . Process improvements of the temperature coefficient of the feedback resistors now make possible specifying a maximum gain drift of the feedback resistors of 35 ppm/ $^{\circ}$ C, thus significantly improving the overall temperature stability of applications using gains greater than 1.

Low resistor values required for high gain can make wiring resistance important. Sockets add to the wiring resistance and contribute additional gain error (such as a possible unstable gain error) at gains of approximately 100 or greater. To ensure stability, avoid parasitic capacitance of more than a few picofarads at  $R_G$  connections. Careful matching of any parasitics on both  $R_G$  pins maintains optimal CMRR over frequency; see typical characteristic curves [Figure 22](#) and [Figure 23](#).

### 7.3.3 Offset Trimming

Most applications require no external offset adjustment; however, if necessary, adjustments can be made by applying a voltage to the REF pin. Figure 66 shows an optional circuit for trimming the output offset voltage. The voltage applied to the REF pin is summed at the output. The op amp buffer provides low impedance at the REF pin to preserve good common-mode rejection.



Copyright © 2017, Texas Instruments Incorporated

**Figure 66. Optional Trimming of Output Offset Voltage**

### 7.3.4 Input Common-Mode Range

The linear input voltage range of the INA826S input circuitry extends from the negative supply voltage to 1 V below the positive supply, and maintains 84-dB (minimum) common-mode rejection throughout this range. The common-mode range for most common operating conditions is described in Figure 12 through Figure 18 and Figure 44 through Figure 46. The INA826S can operate over a wide range of power supplies and  $V_{REF}$  configurations, making a comprehensive guide to common-mode range limits impractical to be provided for all possible conditions.

The most commonly overlooked overload condition occurs when a circuit exceeds the output swing of  $A_1$  and  $A_2$ , which are internal circuit nodes that cannot be measured. Calculating the expected voltages at the output of  $A_1$  and  $A_2$  (see Figure 65) provides a check for the most common overload conditions. The designs of  $A_1$  and  $A_2$  are identical and the outputs can swing to within approximately 100 mV of the power-supply rails. For example, when the  $A_2$  output is saturated,  $A_1$  may continue to be in linear operation, responding to changes in the noninverting input voltage. This difference can give the appearance of linear operation but the output voltage is invalid.

A single-supply instrumentation amplifier has special design considerations. To achieve a common-mode range that extends to single-supply ground, the INA826S employs a current-feedback topology with PNP input transistors; see Figure 65. The matched PNP transistors  $Q_1$  and  $Q_2$  shift the input voltages of both inputs up by a diode drop, and through the feedback network, shift the output of  $A_1$  and  $A_2$  by approximately 0.8 V. With both inputs and  $V_{REF}$  at single-supply ground (negative power supply), the output of  $A_1$  and  $A_2$  is well within the linear range, allowing differential measurements to be made at the GND level. As a result of this input level-shifting, the voltages at pin 2 and pin 3 are not equal to the respective input pin voltages (pin 1 and pin 4). For most applications, this inequality is not important because only the gain-setting resistor connects to these pins.

### 7.3.5 Input Protection

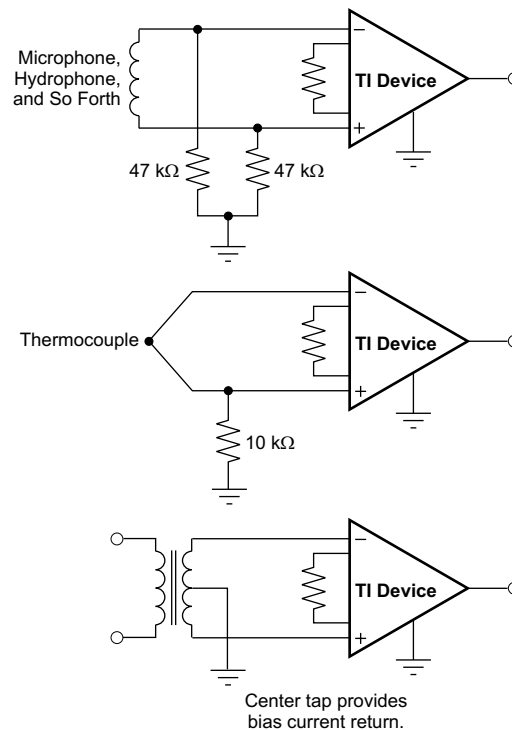
The inputs of the INA826S are individually protected for voltages up to  $\pm 40$  V. For example, a condition of  $-40$  V on one input and  $40$  V on the other input does not cause damage. However, if the input voltage exceeds  $(V-) - 2$  V and the signal source current drive capability exceeds  $3.5$  mA, the output voltage switches to the opposite polarity; see [Figure 20](#). This polarity reversal can easily be avoided by adding resistance of  $10$  k $\Omega$  in series with both inputs.

Internal circuitry on each input provides low series impedance under normal signal conditions. If the input is overloaded, the protection circuitry limits the input current to a safe value of approximately  $8$  mA. [Figure 20](#) and [Figure 21](#) illustrate this input current limit behavior. The inputs are protected even if the power supplies are disconnected or turned off.

### 7.3.6 Input Bias Current Return Path

The input impedance of the INA826S is extremely high—approximately  $20$  G $\Omega$ . However, a path must be provided for the input bias current of both inputs. This input bias current is typically  $35$  nA. High input impedance means that this input bias current changes very little with varying input voltage.

Input circuitry must provide a path for this input bias current for proper operation. [Figure 67](#) shows various provisions for an input bias current path. Without a bias current path, the inputs float to a potential that exceeds the common-mode range of the INA826S, and the input amplifiers saturate. If the differential source resistance is low, as shown in the thermocouple example in [Figure 67](#), the bias current return path can be connected to one input. With higher source impedance, using two equal resistors provides a balanced input with possible advantages of lower input offset voltage as a result of bias current and better high-frequency common-mode rejection.



Copyright © 2017, Texas Instruments Incorporated

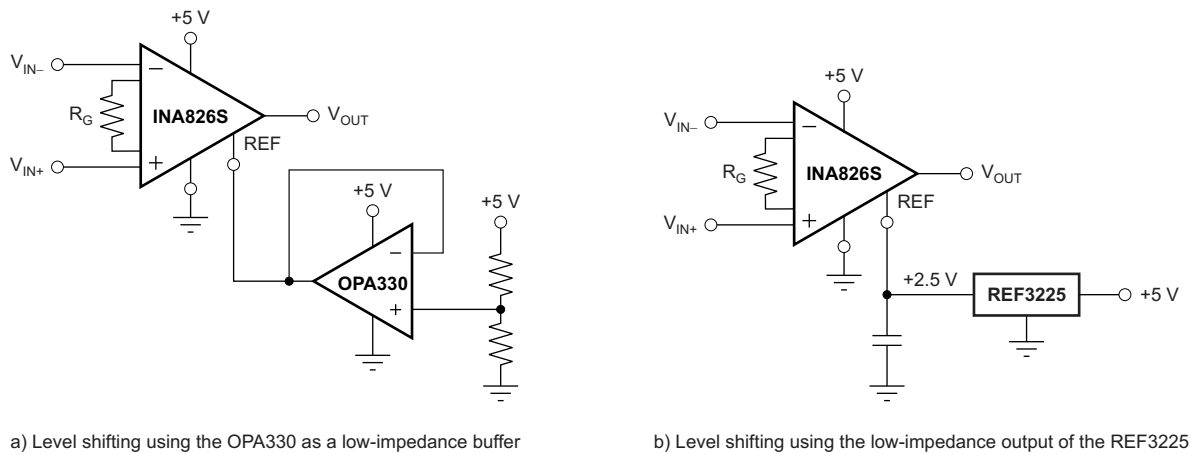
**Figure 67. Providing an Input Common-Mode Current Path**

### 7.3.7 Reference Pin (REF)

The output voltage of the INA826S is developed with respect to the voltage on the reference terminal. Often, in dual-supply operation, the reference pin (pin 6) is connected to the low-impedance system ground. In single-supply operation, offsetting the output signal to a precise mid-supply level can be useful (for example, 2.5 V in a 5-V supply environment). To accomplish this offset, a voltage source can be tied to the REF pin to level-shift the output so that the INA826S can drive a single-supply ADC, for example.

For the best performance, keep the source impedance to the REF pin below 5  $\Omega$ . As shown in , the reference resistor is at one end of a 50-k $\Omega$  resistor. Additional impedance at the REF pin adds to this 50-k $\Omega$  resistor. The imbalance in the resistor ratios results in degraded common-mode rejection ratio (CMRR).

[Figure 68](#) shows two different methods of driving the reference pin with low impedance. The [OPA330](#) is a low-power, chopper-stabilized amplifier, and therefore offers excellent stability over temperature. The OPA330 is available in the space-saving SC70 and even smaller chip-scale package. The [REF3225](#) is a precision reference in the small SOT23-6 package.



a) Level shifting using the OPA330 as a low-impedance buffer

b) Level shifting using the low-impedance output of the REF3225

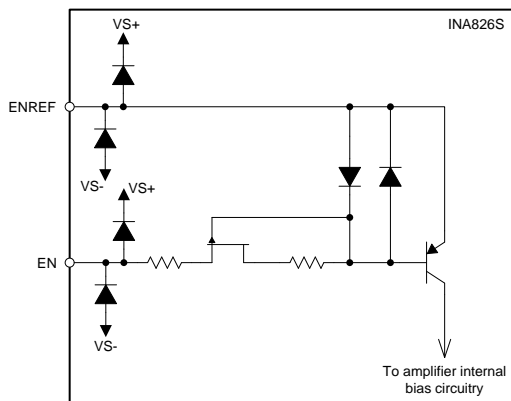
Copyright © 2017, Texas Instruments Incorporated

**Figure 68. Options for Low-Impedance Level Shifting**



### 7.3.8 Shutdown (EN and ENREF) Pins

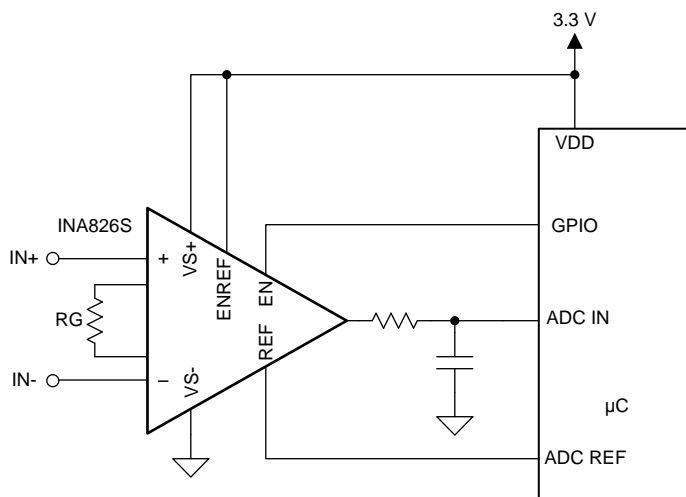
The INA826S provides two pins to shut the device down: EN (enable) and ENREF (enable reference). Figure 69 shows a basic schematic of the shutdown logic circuitry of the INA826S. A PNP transistor forms the basis of the internal shutdown circuitry. The ENREF pin is connected to the emitter of the PNP transistor and is meant to be connected to a voltage reference point for the enable logic. The EN pin is connected to the base of the PNP transistor. Applying a voltage to the EN pin that is 0.8 V or more below the enable reference voltage (at the ENREF pin) causes a small current to flow in the internal PNP transistor that powers the INA826S internal bias circuitry and powers-up the instrumentation amplifier. The shutdown circuitry functions properly with ENREF connected to a voltage between  $(V-) + 1.5\text{ V}$  up to  $V+$ . The voltage on the EN pin can be as low as the negative supply voltage ( $VS-$ ) but cannot go above the voltage applied to the ENREF pin.



Copyright © 2017, Texas Instruments Incorporated

Figure 69. Shutdown Pin Simplified Schematic

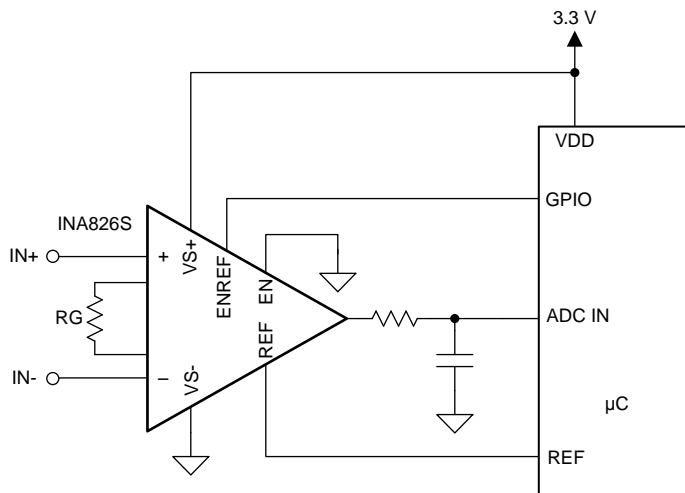
To better understand the functionality of these pins, consider the low-voltage, single-supply application shown in Figure 70 with  $V+ = 3.3\text{ V}$ . ENREF is connected to the 3.3-V power supply of the microcontroller (labeled  $\mu\text{C}$ ) and the EN pin is toggled by a general-purpose input/output (GPIO) pin of the microcontroller. When the GPIO pin is asserted low, such that the voltage at the GPIO pin output is at or near 0 V, the INA826S is enabled. Conversely, if the GPIO pin is asserted high, with an output voltage at or near 3.3 V, the INA826S is disabled.



Copyright © 2017, Texas Instruments Incorporated

Figure 70. Example Configuration in a Single-Supply System (Pulling EN low enables the INA826S.)

Figure 71 shows an alternate configuration of the enable logic pins. By grounding the enable pin, and toggling the ENREF pin with the GPIO of the microcontroller, the enable logic is reversed. Now asserting high at the GPIO output enables the INA826S, and pulling the GPIO pin low disables the INA826S.



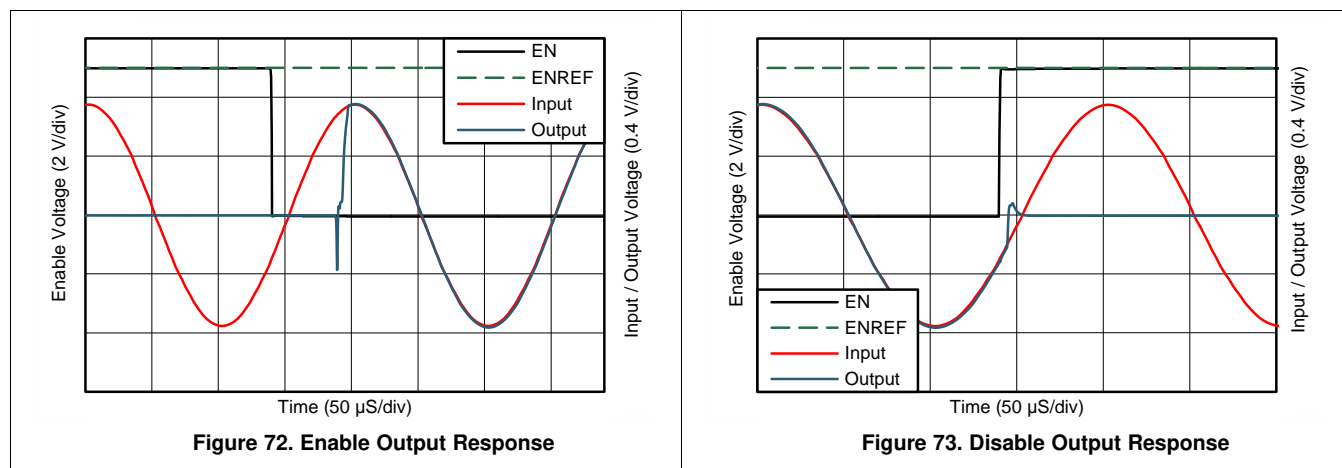
Copyright © 2017, Texas Instruments Incorporated

**Figure 71. Alternate Configuration for the Enable Logic Pins  
(Pulling ENREF high enables the INA826S.)**

The majority of INA826S applications benefit greatly from the reduction of quiescent current from the typical 200  $\mu\text{A}$  to values at or below 6  $\mu\text{A}$ . Achieving the lowest possible system-level current in a system requires attention to other system voltages applied to the INA826S. When shutdown, voltages applied to the reference or input pins of the INA826S can find paths for currents to flow up into the several microamps region. In many systems these voltages are shut down when the INA826S is shutdown, simplifying the problem. Otherwise, additional switching may be added to reduce currents to a minimum.

## 7.4 Device Functional Modes

The INA826S features a shutdown mode that reduces the typical power-supply current consumption from 200  $\mu\text{A}$  to less than 6  $\mu\text{A}$ . Disabling the INA826S turns off the bias circuitry that powers the internal amplifiers of the INA826S. [Figure 72](#) and [Figure 73](#) show the output behavior of the INA826S when the shutdown state is toggled. For these plots, the ENREF pin was connected to a 5-V potential and the EN pin was pulled low to enable the INA826S. [Figure 72](#) shows how quickly the INA826S output responds when transitioning from a shutdown state to an enabled state. When the EN pin is pulled low, the INA826S output begins to track the input signal approximately 60  $\mu\text{s}$  later. When transitioning from enabled to shutdown, as shown in [Figure 73](#), the output of the INA826S stops tracking the input waveform in approximately 10  $\mu\text{s}$ .



## 8 Application and Implementation

### NOTE

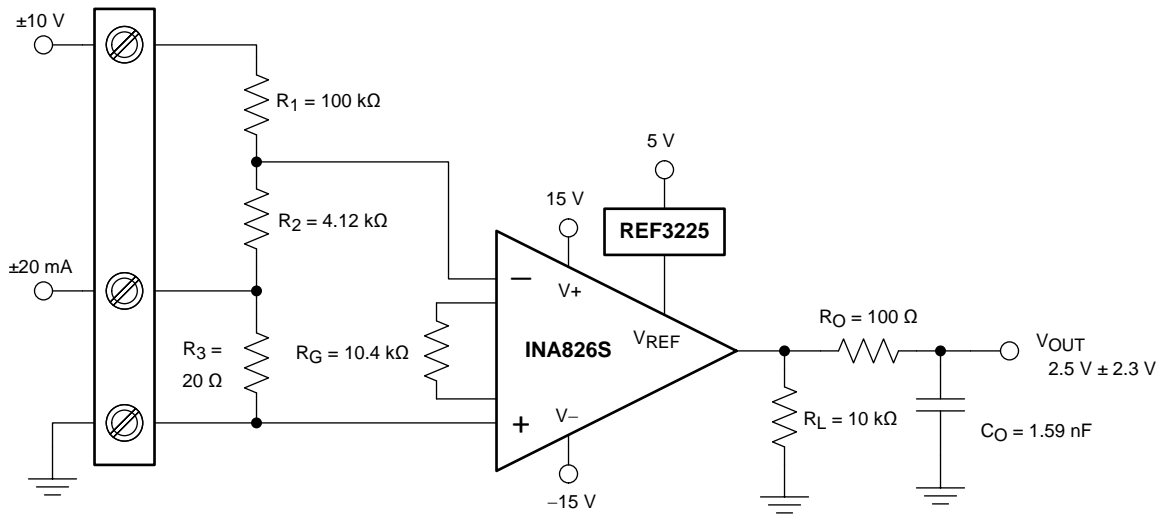
Information in the following applications sections is not part of the TI component specification, and TI does not warrant its accuracy or completeness. TI's customers are responsible for determining suitability of components for their purposes. Customers should validate and test their design implementation to confirm system functionality.

### 8.1 Application Information

The low power consumption and high performance of the INA826S make the device an excellent instrumentation amplifier for many applications. The INA826S can be used in many low-power, portable applications because the device has a low quiescent current (200  $\mu\text{A}$ , typical) and comes in a small 10-pin VSON package. The input protection circuitry, low maximum gain drift, low offset voltage, and 36-V maximum supply voltage also make the INA826S an ideal choice for industrial applications as well.

## 8.2 Typical Application

Figure 74 shows a three-terminal, programmable-logic controller (PLC) design for the INA826S. This PLC reference design accepts inputs of  $\pm 10$  V or  $\pm 20$  mA. The output is a single-ended voltage of  $2.5$  V  $\pm 2.3$  V (or 200 mV to 4.8 V). Many PLCs typically have these input and output ranges.



Copyright © 2017, Texas Instruments Incorporated

**Figure 74. Three-Terminal Analog Input for PLCs**

### 8.2.1 Design Requirements

This design has the following requirements:

- Supply voltage:  $\pm 15$  V, 5 V
- Inputs:  $\pm 10$  V,  $\pm 20$  mA
- Output: 2.5 V,  $\pm 2.3$  V

### 8.2.2 Detailed Design Procedure

There are two modes of operation for the circuit shown in Figure 74: current input and voltage input. This design requires  $R_1 \gg R_2 \gg R_3$ . Given this relationship, Equation 2 calculates the current input mode transfer function.

$$V_{\text{OUT-I}} = V_D \times G + V_{\text{REF}} = -(I_{\text{IN}} \times R_3) \times G + V_{\text{REF}}$$

where

- G represents the gain of the instrumentation amplifier (2)

Equation 3 shows the transfer function for the voltage input mode.

$$V_{\text{OUT-V}} = V_D \times G + V_{\text{REF}} = -\left[V_{\text{IN}} \times \frac{R_2}{R_1 + R_2}\right] \times G + V_{\text{REF}} \quad (3)$$

$R_1$  sets the input impedance of the voltage input mode. The minimum typical input impedance is 100 k $\Omega$ . 100 k $\Omega$  is selected for  $R_1$  because increasing the  $R_1$  value also increases noise. The value of  $R_3$  must be extremely small compared to  $R_1$  and  $R_2$ . 20  $\Omega$  for  $R_3$  is selected because that resistance value is much smaller than  $R_1$  and yields an input voltage of  $\pm 400$  mV when operated in current mode ( $\pm 20$  mA).

Equation 4 can be used to calculate  $R_2$  given  $V_D = \pm 400$  mV,  $V_{\text{IN}} = \pm 10$  V, and  $R_1 = 100$  k $\Omega$ .

$$V_D = V_{\text{IN}} \times \frac{R_2}{R_1 + R_2} \rightarrow R_2 = \frac{R_1 \times V_D}{V_{\text{IN}} - V_D} = 4.167 \text{ k}\Omega \quad (4)$$

### Typical Application (continued)

The value obtained from Equation 4 is not a standard 0.1% value, so 4.12 kΩ is selected. R<sub>1</sub> and R<sub>2</sub> also use 0.1% tolerance resistors to minimize error.

Use Equation 5 to calculate the ideal gain of the instrumentation amplifier.

$$G = \frac{V_{OUT} - V_{REF}}{V_D} = \frac{4.8 \text{ V} - 2.5 \text{ V}}{400 \text{ mV}} = 5.75 \frac{\text{V}}{\text{V}} \tag{5}$$

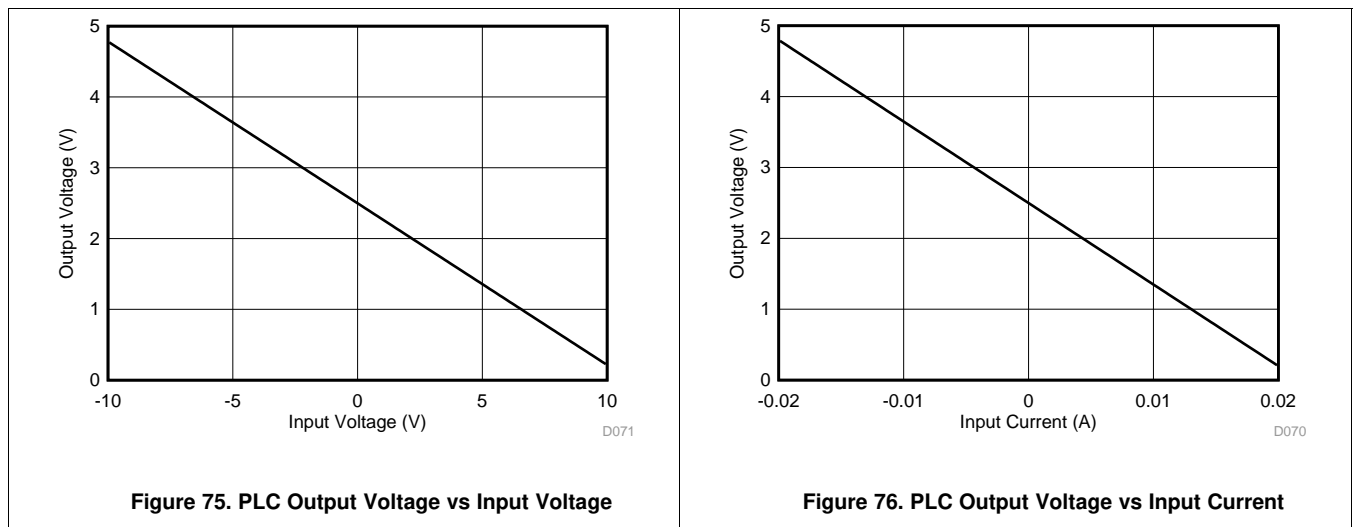
Equation 6 calculates the gain-setting resistor value using the INA826S gain equation, Equation 1.

$$G_{INA826} = 1 + \frac{49.4 \text{ k}\Omega}{R_G} \rightarrow R_G = \frac{49.4 \text{ k}\Omega}{G_{INA826} - 1} = \frac{49.4 \text{ k}\Omega}{5.75 - 1} = 10.4 \text{ k}\Omega \tag{6}$$

10.4 kΩ is a standard 0.1% resistor value that can be used in this design. Finally, the output RC filter components are selected to have a –3-dB cutoff frequency of 1 MHz.

### 8.2.3 Application Curves

Figure 75 and Figure 76 show typical characteristic curves for Figure 74.



## 9 Power Supply Recommendations

The INA826S operates over a power-supply range of 3 V to 36 V ( $\pm 3$  V to  $\pm 18$  V). Supply voltages higher than 40 V ( $\pm 20$  V) can permanently damage the device. Parameters that vary over supply voltage or temperature are illustrated in the [Typical Characteristics](#) section.

### 9.1 Low-Voltage Operation

The INA826S can operate on power supplies as low as 3 V. Most parameters vary only slightly throughout this supply voltage range; see the [Typical Characteristics](#) section. Operation at very low supply voltage requires careful attention to assure that the input voltages remain within the linear range. Voltage swing requirements of internal nodes limit the input common-mode range with low power-supply voltage. The typical characteristic curves [Figure 12](#) through [Figure 18](#) and [Figure 44](#) through [Figure 46](#) describe the range of linear operation for various supply voltages, reference connections, and gains.

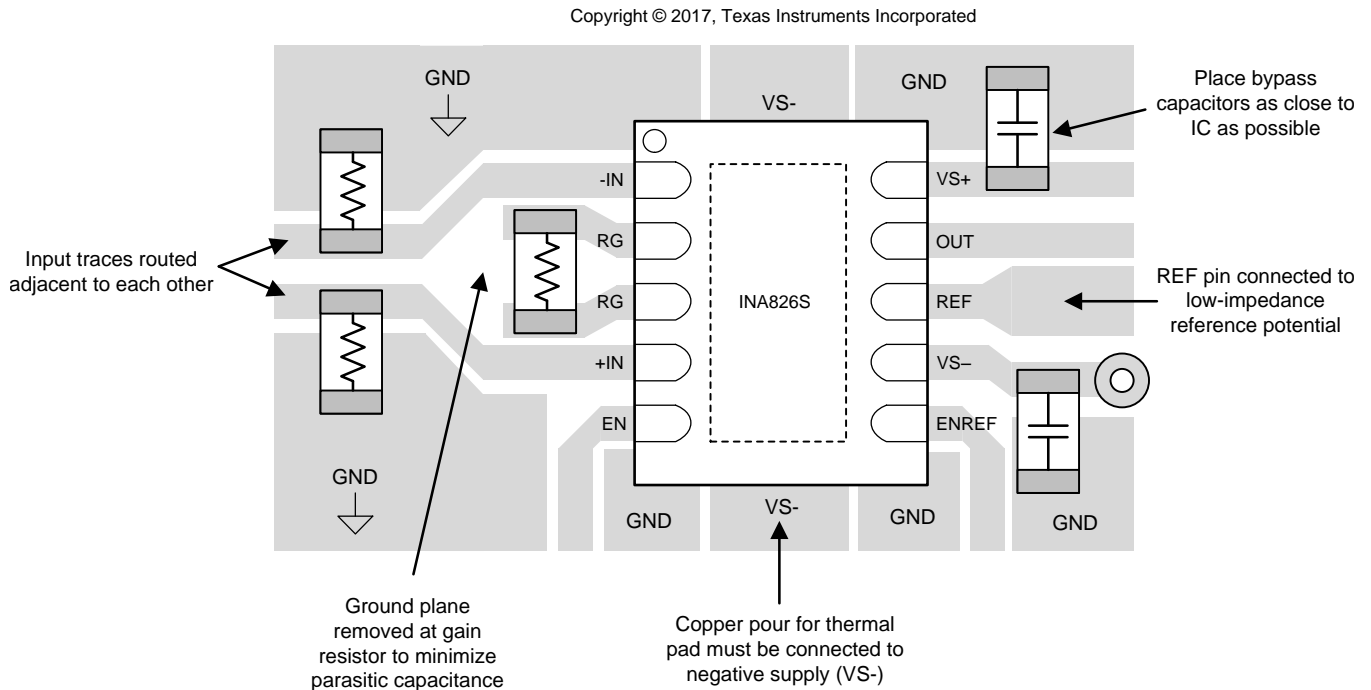
## 10 Layout

### 10.1 Layout Guidelines

For best operational performance of the device, use good printed circuit board (PCB) layout practices, including:

- Connect low-ESR, 0.1- $\mu$ F ceramic bypass capacitors between each supply pin and ground, placed as close to the device as possible. A single bypass capacitor from  $V_+$  to ground is applicable for single-supply applications. The bypass capacitors are used to reduce the coupled noise by providing low-impedance power sources local to the analog circuitry, because noise can propagate into analog circuitry through the power pins of the circuit as a whole and the op amp specifically.
- Connect the device reference pin to a low-impedance, low-noise, system reference point, such as an analog ground. If a potential other than ground is used as a reference, a low output impedance (such as a voltage divider with an op amp buffer) must be included.
- Minimize the parasitic capacitance and inductance present at the gain resistor connections. Place the gain resistor as close to the device as possible, and remove the ground plane around the gain resistor to minimize parasitic capacitances at these nodes.
- For best performance, route the input traces adjacent to each other as a differential pair.
- For proper amplifier function, connect the package thermal pad to the most negative supply voltage ( $V_{EE}$ ).

### 10.2 Layout Example



**Figure 77. INA826S PCB Layout Example**

## 11 Device and Documentation Support

### 11.1 Documentation Support

#### 11.1.1 Related Documentation

For related documentation see the following:

- [OPAx330 50- \$\mu\$ V VOS, 0.25- \$\mu\$ V/ \$^{\circ}\$ C, 35- \$\mu\$ A CMOS Operational Amplifiers Zero-Drift Series](#)
- [REF32xx 4ppm/ \$^{\circ}\$ C, 100 \$\mu\$ A, SOT23-6 Series Voltage Reference](#)
- [REF50xx Low-Noise, Very Low Drift, Precision Voltage Reference](#)
- [SPICE-Based Analog Simulation Program](#)

#### 11.2 Receiving Notification of Documentation Updates

To receive notification of documentation updates, navigate to the device product folder on ti.com. In the upper right corner, click on *Alert me* to register and receive a weekly digest of any product information that has changed. For change details, review the revision history included in any revised document.

#### 11.3 Community Resources

The following links connect to TI community resources. Linked contents are provided "AS IS" by the respective contributors. They do not constitute TI specifications and do not necessarily reflect TI's views; see TI's [Terms of Use](#).

**TI E2E™ Online Community** *TI's Engineer-to-Engineer (E2E) Community*. Created to foster collaboration among engineers. At e2e.ti.com, you can ask questions, share knowledge, explore ideas and help solve problems with fellow engineers.

**Design Support** *TI's Design Support* Quickly find helpful E2E forums along with design support tools and contact information for technical support.

#### 11.4 Trademarks

E2E is a trademark of Texas Instruments.

All other trademarks are the property of their respective owners.

#### 11.5 Electrostatic Discharge Caution



This integrated circuit can be damaged by ESD. Texas Instruments recommends that all integrated circuits be handled with appropriate precautions. Failure to observe proper handling and installation procedures can cause damage.

ESD damage can range from subtle performance degradation to complete device failure. Precision integrated circuits may be more susceptible to damage because very small parametric changes could cause the device not to meet its published specifications.

#### 11.6 Glossary

[SLYZ022](#) — *TI Glossary*.

This glossary lists and explains terms, acronyms, and definitions.

## 12 Mechanical, Packaging, and Orderable Information

The following pages include mechanical, packaging, and orderable information. This information is the most current data available for the designated devices. This data is subject to change without notice and revision of this document. For browser-based versions of this data sheet, refer to the left-hand navigation.



**PACKAGING INFORMATION**

Orderable Device	Status (1)	Package Type	Package Drawing	Pins	Package Qty	Eco Plan (2)	Lead finish/ Ball material (6)	MSL Peak Temp (3)	Op Temp (°C)	Device Marking (4/5)	Samples
INA826SIDRCR	ACTIVE	VSON	DRC	10	3000	RoHS & Green	NIPDAU	Level-1-260C-UNLIM	-40 to 125	IN826S	<a href="#">Samples</a>
INA826SIDRCT	ACTIVE	VSON	DRC	10	250	RoHS & Green	NIPDAU	Level-1-260C-UNLIM	-40 to 125	IN826S	<a href="#">Samples</a>

(1) The marketing status values are defined as follows:

**ACTIVE:** Product device recommended for new designs.

**LIFEBUY:** TI has announced that the device will be discontinued, and a lifetime-buy period is in effect.

**NRND:** Not recommended for new designs. Device is in production to support existing customers, but TI does not recommend using this part in a new design.

**PREVIEW:** Device has been announced but is not in production. Samples may or may not be available.

**OBSOLETE:** TI has discontinued the production of the device.

(2) **RoHS:** TI defines "RoHS" to mean semiconductor products that are compliant with the current EU RoHS requirements for all 10 RoHS substances, including the requirement that RoHS substance do not exceed 0.1% by weight in homogeneous materials. Where designed to be soldered at high temperatures, "RoHS" products are suitable for use in specified lead-free processes. TI may reference these types of products as "Pb-Free".

**RoHS Exempt:** TI defines "RoHS Exempt" to mean products that contain lead but are compliant with EU RoHS pursuant to a specific EU RoHS exemption.

**Green:** TI defines "Green" to mean the content of Chlorine (Cl) and Bromine (Br) based flame retardants meet JS709B low halogen requirements of <=1000ppm threshold. Antimony trioxide based flame retardants must also meet the <=1000ppm threshold requirement.

(3) MSL, Peak Temp. - The Moisture Sensitivity Level rating according to the JEDEC industry standard classifications, and peak solder temperature.

(4) There may be additional marking, which relates to the logo, the lot trace code information, or the environmental category on the device.

(5) Multiple Device Markings will be inside parentheses. Only one Device Marking contained in parentheses and separated by a "~" will appear on a device. If a line is indented then it is a continuation of the previous line and the two combined represent the entire Device Marking for that device.

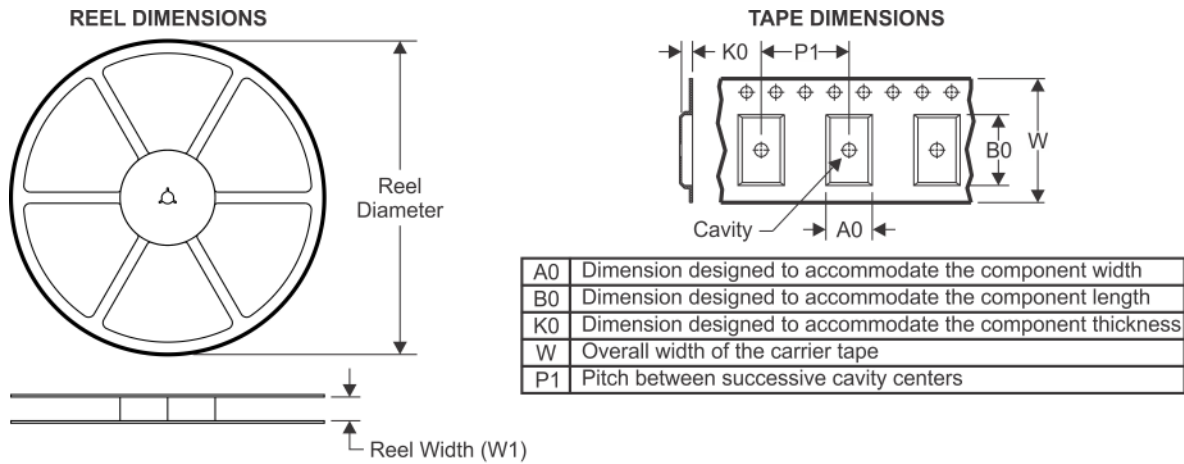
(6) Lead finish/Ball material - Orderable Devices may have multiple material finish options. Finish options are separated by a vertical ruled line. Lead finish/Ball material values may wrap to two lines if the finish value exceeds the maximum column width.

**Important Information and Disclaimer:**The information provided on this page represents TI's knowledge and belief as of the date that it is provided. TI bases its knowledge and belief on information provided by third parties, and makes no representation or warranty as to the accuracy of such information. Efforts are underway to better integrate information from third parties. TI has taken and continues to take reasonable steps to provide representative and accurate information but may not have conducted destructive testing or chemical analysis on incoming materials and chemicals. TI and TI suppliers consider certain information to be proprietary, and thus CAS numbers and other limited information may not be available for release.

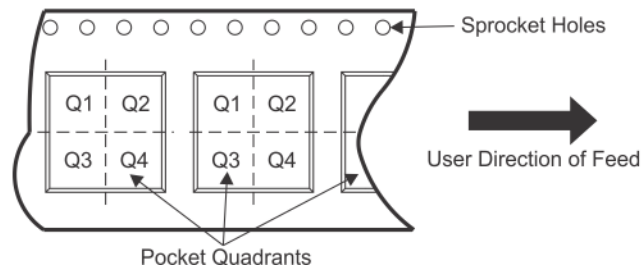
In no event shall TI's liability arising out of such information exceed the total purchase price of the TI part(s) at issue in this document sold by TI to Customer on an annual basis.



## TAPE AND REEL INFORMATION



### QUADRANT ASSIGNMENTS FOR PIN 1 ORIENTATION IN TAPE



\*All dimensions are nominal

Device	Package Type	Package Drawing	Pins	SPQ	Reel Diameter (mm)	Reel Width W1 (mm)	A0 (mm)	B0 (mm)	K0 (mm)	P1 (mm)	W (mm)	Pin1 Quadrant
INA826SIDRCR	VSON	DRC	10	3000	330.0	12.4	3.3	3.3	1.1	8.0	12.0	Q2
INA826SIDRCT	VSON	DRC	10	250	180.0	12.4	3.3	3.3	1.1	8.0	12.0	Q2

**TAPE AND REEL BOX DIMENSIONS**


\*All dimensions are nominal

Device	Package Type	Package Drawing	Pins	SPQ	Length (mm)	Width (mm)	Height (mm)
INA826SIDRCR	VSON	DRC	10	3000	367.0	367.0	35.0
INA826SIDRCT	VSON	DRC	10	250	210.0	185.0	35.0

## GENERIC PACKAGE VIEW

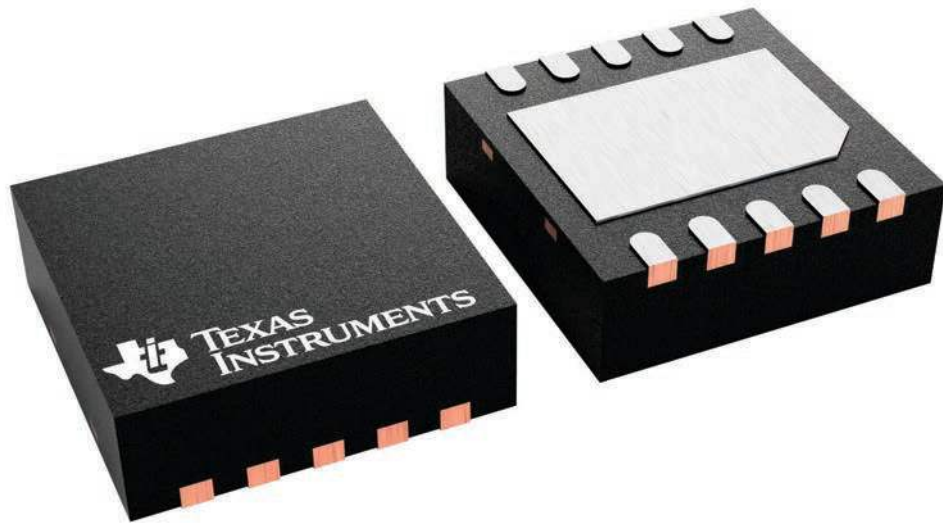
**DRC 10**

**VSON - 1 mm max height**

3 x 3, 0.5 mm pitch

PLASTIC SMALL OUTLINE - NO LEAD

This image is a representation of the package family, actual package may vary.  
Refer to the product data sheet for package details.



4226193/A

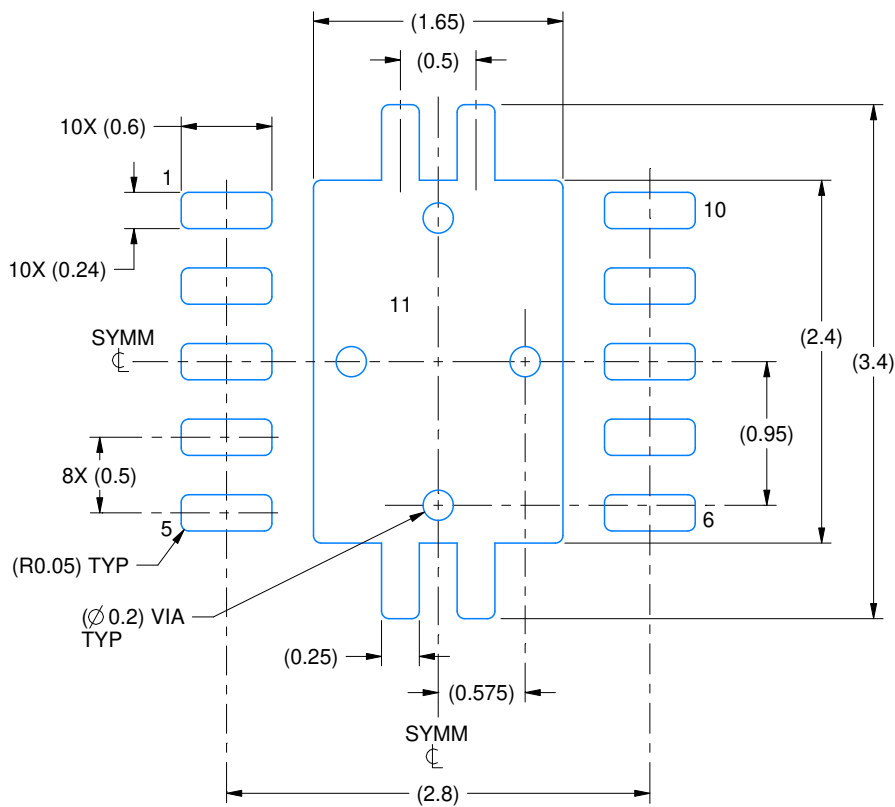


# EXAMPLE BOARD LAYOUT

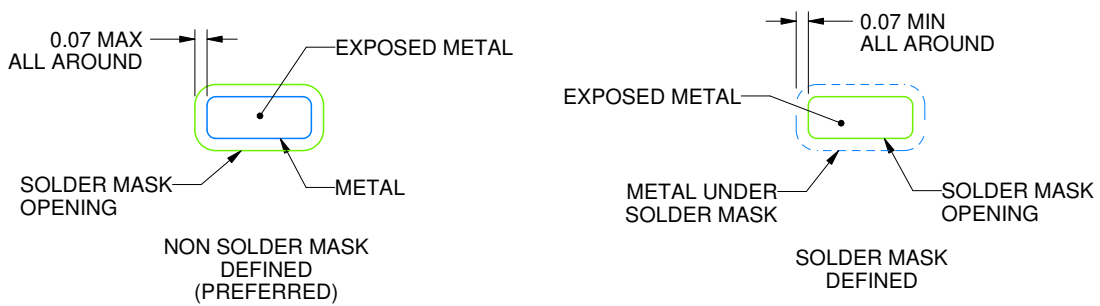
DRC0010J

VSON - 1 mm max height

PLASTIC SMALL OUTLINE - NO LEAD



LAND PATTERN EXAMPLE  
EXPOSED METAL SHOWN  
SCALE:20X



SOLDER MASK DETAILS

4218878/B 07/2018

NOTES: (continued)

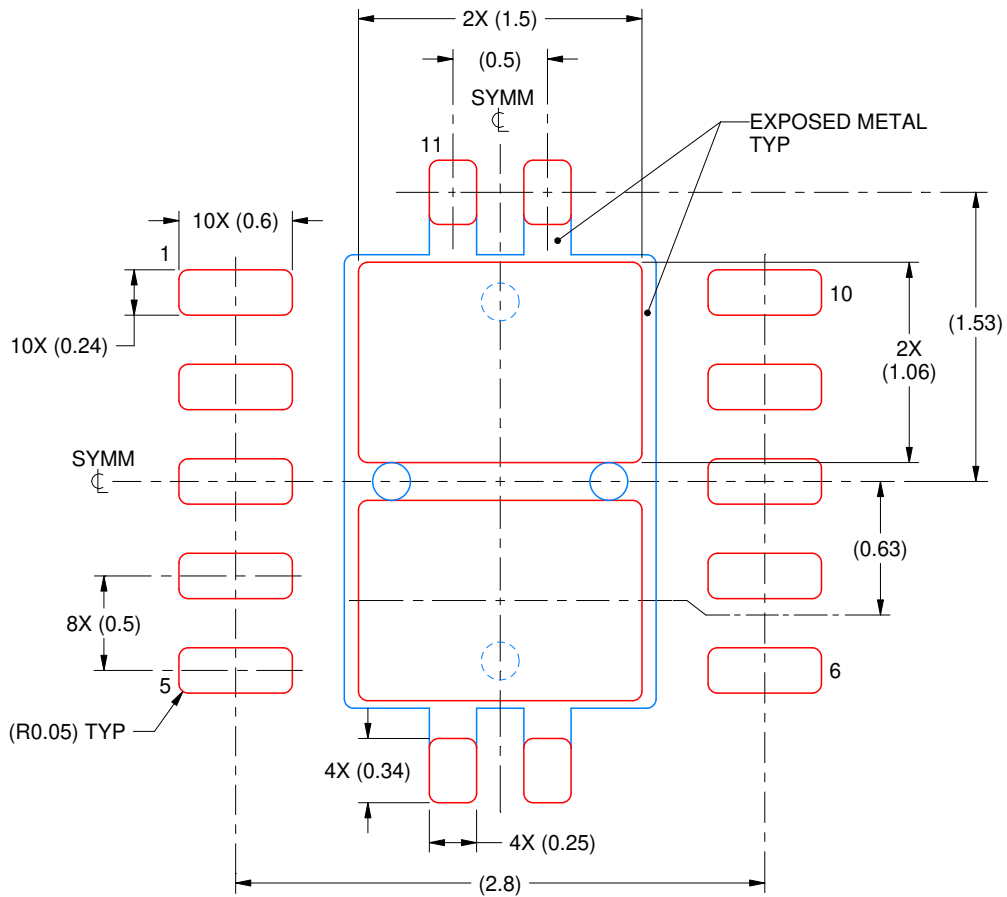
4. This package is designed to be soldered to a thermal pad on the board. For more information, see Texas Instruments literature number SLUA271 ([www.ti.com/lit/sluea271](http://www.ti.com/lit/sluea271)).
5. Vias are optional depending on application, refer to device data sheet. If any vias are implemented, refer to their locations shown on this view. It is recommended that vias under paste be filled, plugged or tented.

# EXAMPLE STENCIL DESIGN

DRC0010J

VSON - 1 mm max height

PLASTIC SMALL OUTLINE - NO LEAD



SOLDER PASTE EXAMPLE  
BASED ON 0.125 mm THICK STENCIL

EXPOSED PAD 11:  
80% PRINTED SOLDER COVERAGE BY AREA  
SCALE:25X

4218878/B 07/2018

NOTES: (continued)

6. Laser cutting apertures with trapezoidal walls and rounded corners may offer better paste release. IPC-7525 may have alternate design recommendations.



## IMPORTANT NOTICE AND DISCLAIMER

TI PROVIDES TECHNICAL AND RELIABILITY DATA (INCLUDING DATASHEETS), DESIGN RESOURCES (INCLUDING REFERENCE DESIGNS), APPLICATION OR OTHER DESIGN ADVICE, WEB TOOLS, SAFETY INFORMATION, AND OTHER RESOURCES "AS IS" AND WITH ALL FAULTS, AND DISCLAIMS ALL WARRANTIES, EXPRESS AND IMPLIED, INCLUDING WITHOUT LIMITATION ANY IMPLIED WARRANTIES OF MERCHANTABILITY, FITNESS FOR A PARTICULAR PURPOSE OR NON-INFRINGEMENT OF THIRD PARTY INTELLECTUAL PROPERTY RIGHTS.

These resources are intended for skilled developers designing with TI products. You are solely responsible for (1) selecting the appropriate TI products for your application, (2) designing, validating and testing your application, and (3) ensuring your application meets applicable standards, and any other safety, security, or other requirements. These resources are subject to change without notice. TI grants you permission to use these resources only for development of an application that uses the TI products described in the resource. Other reproduction and display of these resources is prohibited. No license is granted to any other TI intellectual property right or to any third party intellectual property right. TI disclaims responsibility for, and you will fully indemnify TI and its representatives against, any claims, damages, costs, losses, and liabilities arising out of your use of these resources.

TI's products are provided subject to TI's Terms of Sale (<https://www.ti.com/legal/termsofsale.html>) or other applicable terms available either on [ti.com](https://www.ti.com) or provided in conjunction with such TI products. TI's provision of these resources does not expand or otherwise alter TI's applicable warranties or warranty disclaimers for TI products.

Mailing Address: Texas Instruments, Post Office Box 655303, Dallas, Texas 75265  
Copyright © 2021, Texas Instruments Incorporated