

MAX31840

MR16 LED Driver with Integrated Control MOSFET and Deep Dimming

General Description

The MAX31840 is an LED driver IC for dimmable 12V MR16, as well as AR111 and other 12V lighting applications. This next-generation MR16 LED driver minimizes BOM count, cost, and board space by integrating a number of value-added functions: deep dimming, bleeder control, constant brightness control, and a boost FET; while significantly improving electronic transformer compatibility with standard trailing-edge dimmers. The MAX31840 is designed for the boost architecture to address 35W and higher-wattage MR16 LED replacement bulbs.

The MAX31840 is a high-end MR16 LED driver that incorporates a proprietary circuit that enables deep dimming down to ~1%; an improvement over others that only dim down to 10% or 20%. An integrated bleeder and constant brightness controller enables the MAX31840 to shine, flicker-free, with a broad range of electronic transformers. An optimized compensation circuit and boost FET are integrated to further reduce BOM and board space, simplifying design and saving cost.

The MAX31840 is available in an 8-pin, 3mm x 3mm TDFN enhanced power package and is rated over the -40°C to +125°C operating temperature range.

Applications

- 12V MR16 GU5.3 LED Bulb
- Other 12V LED bulbs (MR11, AR111, 12V Track Lighting)

Benefits and Features

- High Integration Saves PCB Space and BOM Costs
 - 36V Boost N-Channel DMOS FET
 - Bleeder FET Control
 - Deep Dimming Control
 - Constant Brightness Control
 - Internal Compensation
 - LED Overvoltage Protection
 - Overcurrent and Overtemperature Protection
- High-Performance for New LED Dimming Requirements
 - Meets California Title 24 Part 6 JA8
 - Flickering < 30%
 - > 0.9 Power Factor
 - Dimming to <1% Brightness, Depending on LEDs
 - Tight LED Current Regulation of 2% Typical

Ordering Information appears at end of data sheet.

Absolute Maximum Ratings

IN, DRAIN to GND	-0.3V to +36V	Any Pin to Any Pin ESD Rating.....	±2kV(HBM)
ACREC to GND.....	-0.3V to +26V	Operating Temperature Range.....	-40°C to +125°C
AVDET, BGT, BSRC to GND.....	-0.3V to +6V	Maximum Junction Temperature	+150°C
CS, SOURCE to GND.....	-0.3V to 1.5V	Storage Temperature Range	-65°C to +150°C
Maximum RMS Current Through DRAIN and SOURCE	±1A	Lead Temperature (soldering, 10s)	+300°C
Continuous Power Dissipation (T _A = +70°C) TDFN (derate 23.8mW/°C above +70°C)	1904mW	Soldering Temperature (reflow).....	+260°C

Stresses beyond those listed under "Absolute Maximum Ratings" may cause permanent damage to the device. These are stress ratings only, and functional operation of the device at these or any other conditions beyond those indicated in the operational sections of the specifications is not implied. Exposure to absolute maximum rating conditions for extended periods may affect device reliability.

Package Information

8 TDFN-EP

PACKAGE CODE	T833+3
Outline Number	21-0137
Land Pattern Number	90-0059
Thermal Resistance, Single-Layer Board:	
Junction to Ambient (θ _{JA})	54
Junction to Case (θ _{JC})	8
Thermal Resistance, Four-Layer Board:	
Junction to Ambient (θ _{JA})	42
Junction to Case (θ _{JC})	8

For the latest package outline information and land patterns (footprints), go to www.maximintegrated.com/packages. Note that a "+", "#", or "-" in the package code indicates RoHS status only. Package drawings may show a different suffix character, but the drawing pertains to the package regardless of RoHS status.

Package thermal resistances were obtained using the method described in JEDEC specification JESD51-7, using a four-layer board. For detailed information on package thermal considerations, refer to www.maximintegrated.com/thermal-tutorial.

Electrical Characteristics

(V_{IN} = V_{ACDEC} = 12V; V_{ACREC} = V_{SOURCE} = V_{CS} = V_{GND} = 0V; 1kΩ from DRAIN to IN, 100kΩ from BSRC to BGT; T_A = T_J = -40°C to +125°C, unless otherwise noted. Typical values are at T_A = +25°C.) (Note 1)

PARAMETER	SYMBOL	CONDITIONS	MIN	TYP	MAX	UNITS
Operating Voltage Range	V _{IN}	Guaranteed by Undervoltage Lockout and IN Overvoltage Protection	6.5		26	V
IN Supply Current	I _{IN}	When MOSFET fully on, V _{CS} = 0.		1	2.3	mA
		When MOSFET switching at 60% duty, refers to Typical Application Circuit, when V _{LED} /V _{ACREC} = 30V/12V, measure IN current		1.5	3.2	
Undervoltage Lockout	UVLO _{IN}	IN rising, when DRAIN goes low	5	5.6	6.1	V
UVLO Hysteresis				200		mV
IN Overvoltage Protection	V _{OVP}	IN rising, when DRAIN goes high	34.8	35.9	37	V
IN Overvoltage Hysteresis				1.15		V
Switching Frequency		Switching frequency at DRAIN	630	700	770	kHz

Electrical Characteristics (continued)

($V_{IN} = V_{ACDEC} = 12V$; $V_{ACREC} = V_{SOURCE} = V_{CS} = V_{GND} = 0V$; $1k\Omega$ from DRAIN to IN, $100k\Omega$ from BSRC to BGT; $T_A = T_J = -40^\circ C$ to $+125^\circ C$, unless otherwise noted. Typical values are at $T_A = +25^\circ C$.) (Note 1)

PARAMETER	SYMBOL	CONDITIONS	MIN	TYP	MAX	UNITS	
CS Average Voltage		$T_A = +25^\circ C$	196	200	204	mV	
		$-40^\circ C \leq T_A \leq +125^\circ C$	190		210		
Power Switch On-Resistance	R_{DSON}	$I_{DS} = 1A$		100	200	m Ω	
Switch Leakage Current	I_{LEAK}	$V_{DRAIN} = 36V, T_A = 25^\circ C$		0.01	20	μA	
DRAIN Rise Time	t_{RDRAIN}	$I_{DS} = 1A$		10		ns	
DRAIN Fall Time	t_{FDRAIN}	$I_{DS} = 1A$		10		ns	
SOURCE Limit Threshold	$V_{SOURCEETH}$	SOURCE connected to CS	0.66	0.72	0.78	V	
SOURCE Current-Limit Comparator Propagation Delay				25		ns	
CS Input Bias Current	I_{CS}	$V_{CS} = 0V$ and $V_{CS} = 0.3V, T_A = 25^\circ C$	-1		+1	μA	
Thermal-Shutdown Temperature		Temperature rising		165		$^\circ C$	
Thermal Shutdown Hysteresis				15		$^\circ C$	
ACREC Input Threshold	V_{ACREC}	ACREC rising	3.5	3.8	4.2	V	
ACREC Constant Brightness Center Point	$V_{THAVREC}$	V_{ACREC} when $V_{CS} = 0.2V$ (constant brightness center point)	11.4	12	12.6	V	
ACREC Constant Brightness Range		Where LED brightness is held constant		12 $\pm 15\%$		V	
BSRC Voltage	V_{BSRC}	Bleeder in regulation	0.475	0.5	0.525	V	
Bleeder Startup Pulse	t_{OS}	From ACREC rising to BGT falling		75		μs	
CS Bleeder Enable Threshold	$V_{THBLEEDER}$	CS Rising. When CS falling V_{BSRC} goes low, 100mV (typ) hysteresis	186	200	214	mV	
Deep Dim Delay	t_{DIM}	From ACREC high to boost off	$t_{ACREC} = 2ms$	0.9		ms	
			$t_{ACREC} = 4ms$	3.3	3.6		3.9
			$t_{ACREC} = 6ms$	6.3			
BGT Output Voltage		BSRC < 0.5V, output high	1		5.2	V	
		BSRC > 0.5V, output low	0		0.5		

Note 1: All devices are 100% tested at $T_A = T_J = +25^\circ C$. Limits over temperature are guaranteed by design.

Typical Operating Characteristics

($T_A = +25^\circ\text{C}$, unless otherwise noted.)

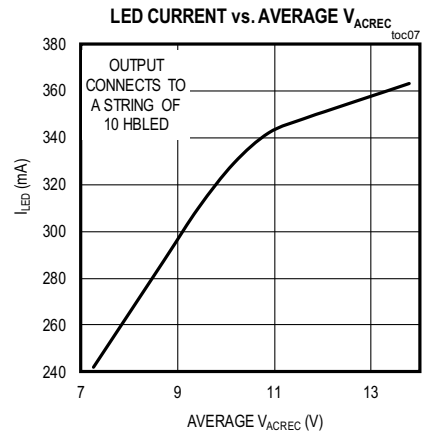
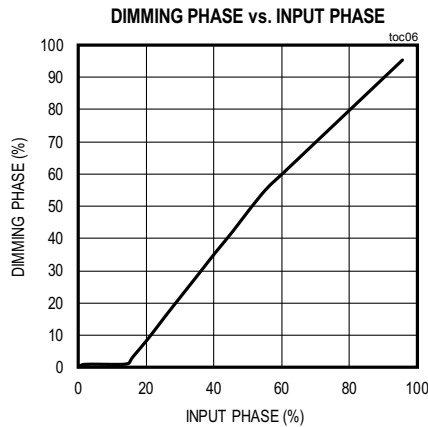
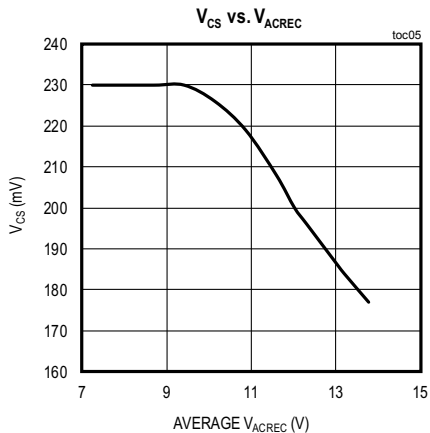
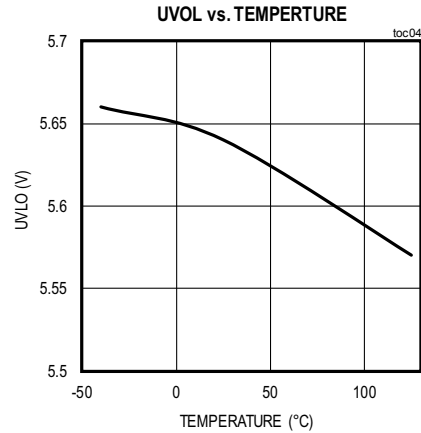
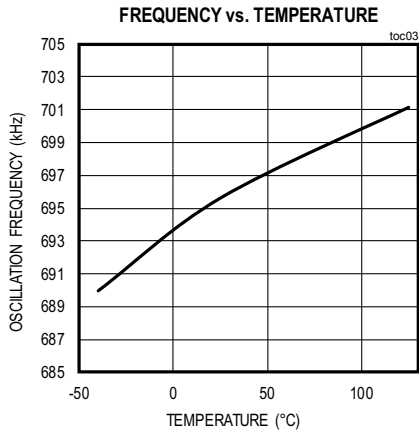
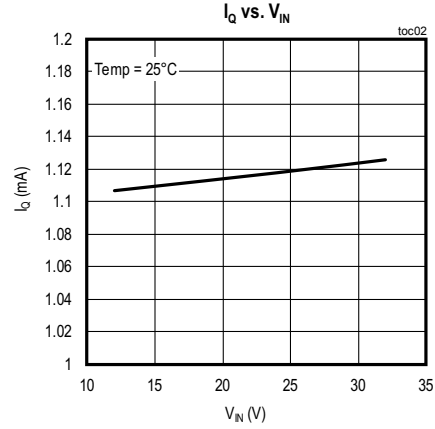
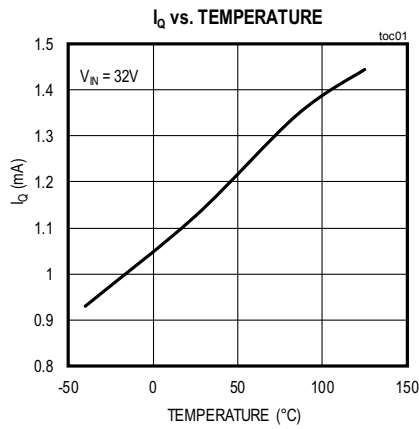

Pin Configuration

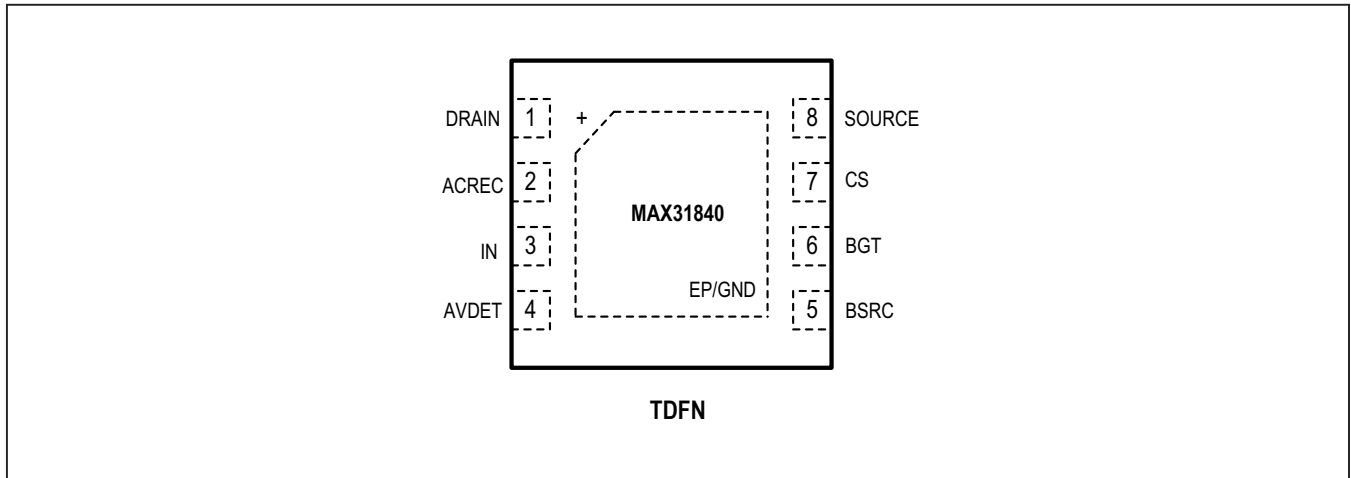

Pin Description

PIN	NAME	FUNCTION
1	DRAIN	Drain of the Internal Switching MOSFET
2	ACREC	Rectified AC Voltage Sensing. Connect this pin to positive side of the rectified AC waveform. Also, connect a bypass capacitor to ground. The zero crossing and dimmer phase information are detected and used to drive an external bleeding FET.
3	IN	Input. Connect to LED string anode to get OVP protection during open LED. Also, input to internal supplies. Bypass it with a 150µF capacitor. Also need a bootstrap diode from rectified input to jump-start internal digital circuit.
4	AVDET	Average AC Voltage Detection. Connect a bypass capacitor to ground for the constant power circuit. This pin is connected to an internal voltage controlled current source.
5	BSRC	Bleeder FET Source Connection. Connect to the source of an NMOS FET for precise bleeding current level control.
6	BGT	Bleeder FET Gate Connection. Connect to the gate of an NMOS FET to supplement input current to maintain electronic transformer operation.
7	CS	Current Sense. This pin includes a 5kΩ/4pF RC filter at its input to average the current information over the switching cycle. Connect this pin directly to SOURCE.
8	SOURCE	Source of the Internal Switching MOSFET
-	GND	Ground via the exposed pad.

Functional Diagram

Internal Functional Block

Refer to the [Simplified Block Diagram](#).

Detailed Description

The MAX31840 is an average current-mode-control LED driver IC for boost topology in low-voltage SSL applications. The IC has an integrated 0.2Ω (max), 36V switching MOSFET that allows the device to be used in lighting applications for MR16 and other SSL applications. The LED driver uses constant-frequency, average current-mode control to control the duty cycle of the integrated switching MOSFET. The IC has all the necessary features required for LED MR16 lighting applications. The IC uses an input-current-control scheme to achieve power factor correction. The IC turns on an external bleeder when the boost operation is off. This feature allows the IC to be compatible with electronic transformers and trailing-edge dimmers (for electronic transformers).

The switch current is sensed on CS. The voltage on CS goes through an internal RC filter. This voltage is then fed to the negative input of a transconductance amplifier. The positive input of the gm amplifier is the programmed input current level. The output voltage of the amplifier is compared with a ramp at the switching frequency to set the duty cycle. The switching frequency is set at 700kHz. The average current-mode controller inside the IC regulates the input current. The IC also features an internal overvoltage protection of 36V on IN to protect the internal switching MOSFET from damage if the LED string is open or if the voltage is too high.

The IC regulates the average voltage on CS to 200mV. The average input current is determined by the value of the resistor connected from the CS pin to ground.

To keep the input power almost constant for line-voltage variation of $\pm 13\%$, a constant brightness circuit has been integrated into the MAX31840. The rectified AC supply after a RC filter, consists of an internal resistor in conjunction with the capacitor connected from the AVDET pin to ground, is used to sense the average voltage level.

The IC has a bleeder gate (BGT) pin and a bleeder source (BSRC) pin for the control of an external bleeder N-channel MOSFET. A bleeder is required to draw current after each AC zero-crossing cycle when the boost converter just get started. The same bleeder is also used to provide deep dimming. The bleeder driving circuit inside the IC maintains the BSRC pin at 0.5V. The bleeder current is determined by the value of the resistor connected from the BSRC pin to the ground.

Internal Oscillator

The IC has an internal oscillator with a fixed switching frequency of 700kHz. 700kHz was chosen to balance between inductor size and EMI emission.

Input Voltage (IN)

The IC is powered by the voltage on IN and needs to be maintained within the operating voltage range of from 6.5V to 35V. An internal UVLO is set at 5.6V. Below 5.4V, there is no switching of the internal power MOSFET and the gate driver for the MOSFET is low. The typical hysteresis of the UVLO threshold is 200mV. There is an internal LDO of 5V that is used to power all the internal circuitry and the gate driver for the internal switching MOSFET. The switching of the internal MOSFET ceases once the rising voltage on IN exceeds 35V and stays off until the voltage on IN drops by 1.2V.

Rectified AC (ACREC)

The ACREC pin senses the zero crossings for the external bleeder driver. The ACREC pin is also used to detect the dimmer phase to drive the same shared external bleeder FET. The zero crossing bleeding happens at every AC zero crossing and lasts a very short time duration. For deep dimming, an internal circuit detects the time duration of the dimming phase per a half AC period. It then turns off the the boost controller at a shorter duration according to the dimming phase for the next half AC period. The smaller the dimming phase the shorter the duration. At around 15° of dimming phase, the deepest dimming is reached per R4 and C1 values on the ACREC pin. For both zero crossing and deep dimming, the bleeder FET is turned on when the LED boost is off, to maintain a minimum input loading on the electronic transformer. The deep dimming control is capable of delivering $<1\%$ of maximum power to the LEDs.

External Bleeder Driver (BGT/BSRC)

The BGT and BSRC pins drive an external N-channel MOSFET for both zero crossing and deep dimming bleeding. A resistor at the BSRC pin to ground is used to configure the electronic transformer loading current during either zero cross and deep dimming. With 0.5V of source voltage, and a 0.5Ω resistor from source to GND, the bleeder would draw 1A from the input when the ACREC voltage is high and the boost regulator is off.

Internal Switching MOSFET

The IC has an integrated switching MOSFET with a maximum $R_{DS(on)}$ of $200m\Omega$ at $+125^\circ\text{C}$. The typical $R_{DS(on)}$ at $+25^\circ\text{C}$ is $100m\Omega$. This allows the IC to be used in a boost LED driver for power levels up to 12W. The maximum voltage rating of the MOSFET is 36V operation. The drain of the internal MOSFET is connected to the DRAIN pin and the source of the internal MOSFET is connected to the SOURCE pin.

Current Sense (CS)

The source of the internal MOSFET is connected to SOURCE. A current-sense resistor must be connected between SOURCE and ground to set the regulated average input current. The current information is read by CS, so SOURCE must be connected to CS. The set point of the current is determined by the IC's control loop and is nominally 200mV. With a 200mΩ R_{CS} resistor, the average input current will be set to 1A. There is a separate peak-limit comparator that terminates switching every cycle if the voltage on CS exceeds 720mV. This comparator has a leading-edge blanking time of 50ns. This limits the peak current in the switching MOSFET and the inductor during transients to 3.6A when the average current is set to 1A.

Control Loop

The IC uses an average current-mode control scheme to regulate the input current. The control loop regulates the average voltage on CS. An internal RC filter removes current spikes appearing on this pin. The current-regulation loop consists of the current-sense resistor R_{CS} , the internal

RC filter, the transconductance error amplifier (gm), the internal compensation circuits, an oscillator providing the 700kHz ramp, the control voltage on the positive input of the gm amplifier, and the PWM comparator (PWMC).

Peak-Limit Comparator

The IC has a peak-limit comparator that limits the peak current in the switching MOSFET. If the current-sense voltage on CS exceeds 0.72V, the peak-limit comparator terminates switching for that switching cycle. This limits the peak current in the switching MOSFET and the inductor during transients.

PWM Comparator

The PWM comparator (PWMC) determines the on-time of the switching MOSFET on a cycle-by-cycle basis by comparing the output of the gm amplifier to a 2V_{P-P} ramp signal. At the start of each clock cycle, an RS flip-flop resets and the gate driver turns on the switching MOSFET. The comparator sets the flip-flop as soon as the ramp signal exceeds the COMP voltage, thus terminating the on cycle.

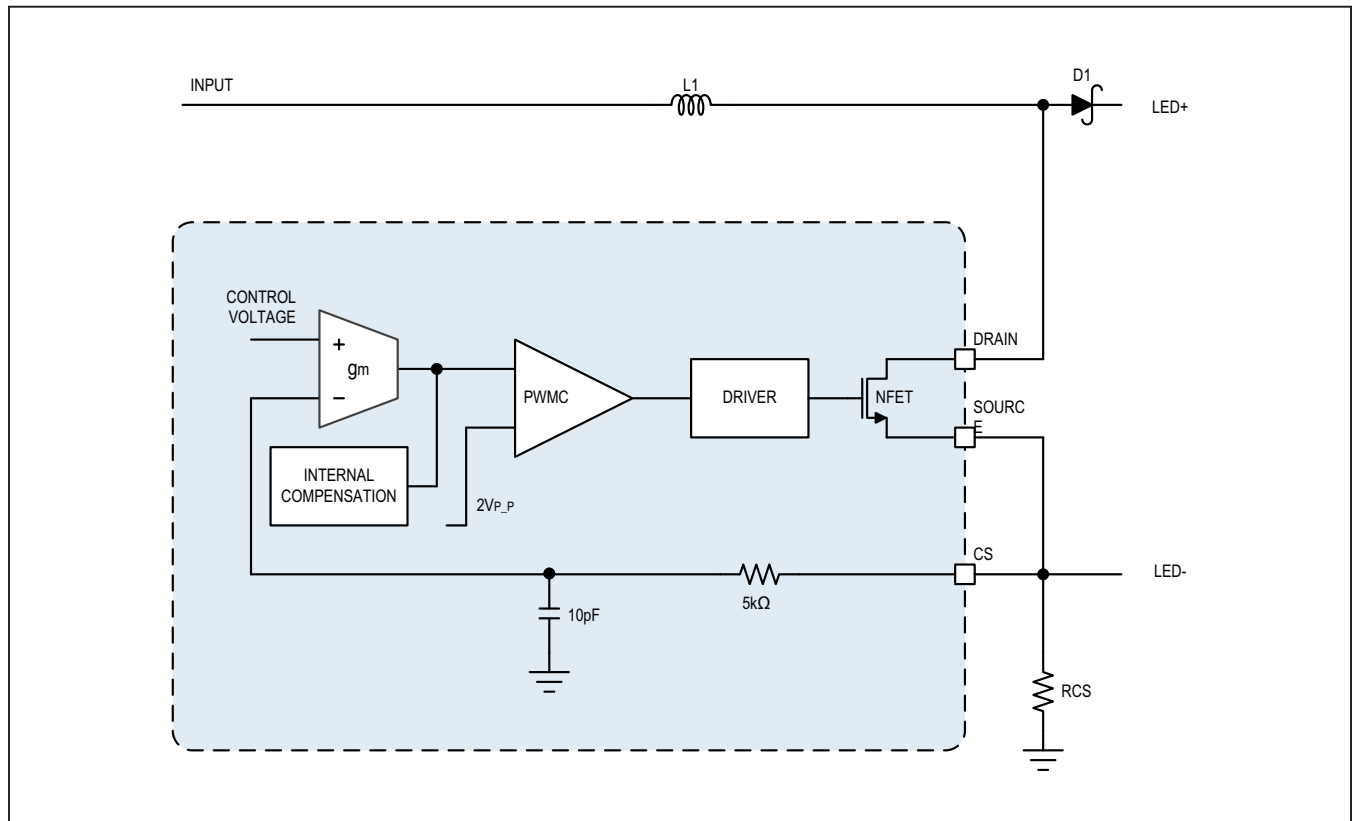

Figure 1. Control Loop

Deep Dimming

Controlled by the same dimmer, a Halogen bulb appears to be more dim-able compared with a LED replacement. The brightness of a Halogen bulb is proportional to the cube of the average voltage across its inputs. [Figure 2](#) shows the supply waveform of a typical electronic transformer with an oscillation frequency of 20kHz for a duration of a half 60Hz AC cycle. The red and blue curves show minimum and maximum dimmer phases of 12% to 70%, respectively. By calculating the area under these curves, we can find that the corresponding average voltage variation is 13:100. For this voltage variation ratio, the brightness variation for a Halogen bulb is about 0.2:100. For the LED

replacement, the brightness variation is only 13:100 since its brightness is linearly proportional to the average voltage across it.

The deep dimming circuit inside the MAX31840 starts to cut down the LED on duration at dimming phase of about 60%. It eventually cuts down the LED-On duration to a minimum at an input phase of about 15%. Since the brightness is determined by the input duty and the sinusoidal input voltage, the deep dimming profile is more gradual at both low and high duties, as seen in [Figure 3](#). The MAX31840 controls the boost regulator and bleeder to maintain continuous input current, while lowering the power delivered to the LED's, in order to achieve this dimming profile.

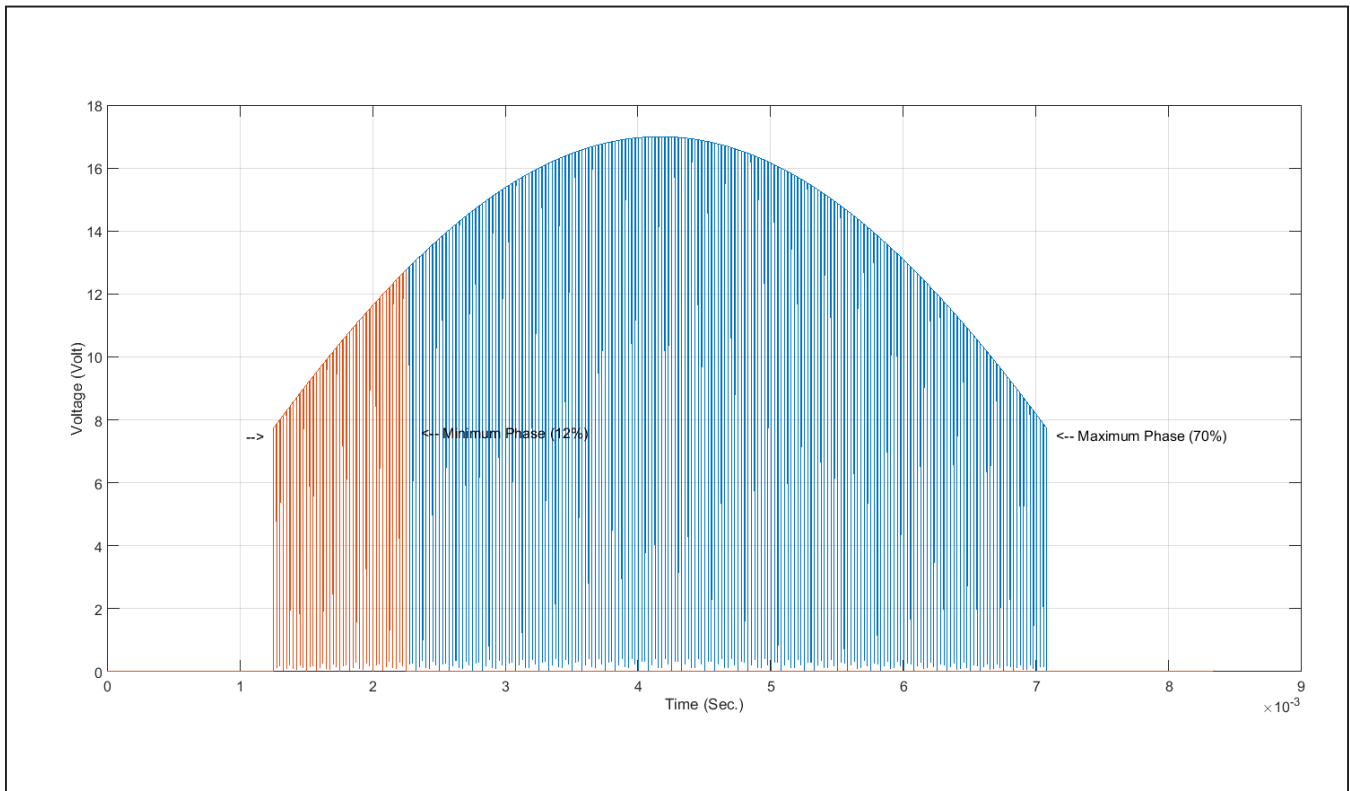

Figure 2. Typical Trailing-Edge Dimming Phase Variation

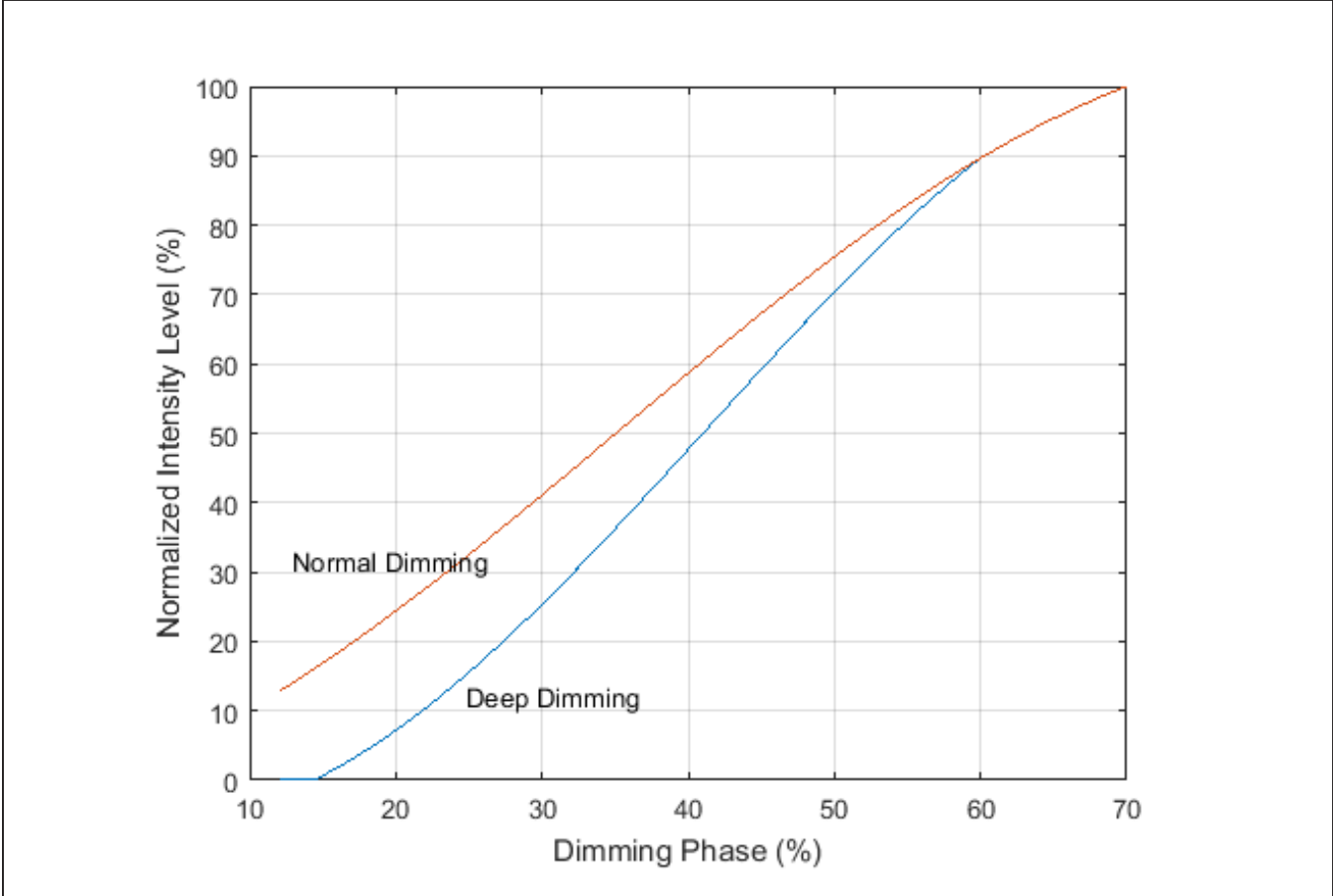

Figure 3. Deep Dimming Effect vs. Dimming Phase of A Dimmer

Applications Information

Boost Configuration

For MR16 and other 12V AC input applications, this MAX31840 boost controller is used for the LED strings with forward voltage exceeds 18V. The number of LEDs can range from 6 to 10 LEDs depending on the forward voltage. The maximum voltage across the LED string should not exceed 34V. In this boost configuration, the current in the inductor is the same as the current in the current-sense resistor R1.

Resistor (R1)

The current in resistor R1 is the same as the current in inductor L1. If the desired maximum output power with 12V AC at 50Hz or 60Hz is P_{OUT} , the input power P_{IN} is given:

$$P_{IN} = P_{OUT}/n$$

where n is the efficiency. The input current is given by:

$$I_{IN} = P_{IN}/12V$$

Resistor R1 is then given by:

$$R1 = 0.2V/I_{IN}$$

where R1 is in ohms and I_{IN} is in amps.

Boost Inductor (L1)

For optimum efficiency, the boost inductor must be operating in continuous-conduction mode. The maximum peak current in the inductor occurs at the peak of the highest input voltage. The peak to peak ripple at this input voltage is ΔI_L . The highest input voltage is 13.2V AC, which is 10% higher than the typical value.

The peak current in the inductor is:

$$I_{PK} = I_{IN} + 0.5\Delta I_L$$

The output voltage of the LED string is given by V_{LED} . As a first-order approximation, the LED voltage is assumed constant. The duty cycle at the peak of the input voltage is therefore:

$$D_{MIN} = 1 - \frac{13.2 \times \sqrt{2}}{V_{LED}} = 1 - \frac{18.66V}{V_{LED}}$$

The percentage peak to peak ripple is typically selected in the 30% to 60% range of the maximum input current. Assuming a 60% peak to peak inductor-current ripple, the maximum inductor current is given by:

$$I_{PK} = 1.3I_{INMAX}$$

The minimum inductor value is given by:

$$L_{MIN} = \frac{18.66V \times D_{MIN}}{0.6I_{INMAX} \times 700kHz}$$

where the switching frequency is 700kHz. The saturation current of the inductor should be higher than peak to peak and the minimum value of the inductor at I_{P-P} should exceed L_{MIN} .

The temperature of the inductor can be in the +90°C to +100°C range in the application and the losses should be estimated at these elevated temperatures.

Boost Diode (D1)

A Schottky diode must be used as rectifier diode D1 to reduce power dissipation. The voltage rating of diode D1 must be greater than the maximum output voltage. Choose a diode that minimizes dissipation at temperatures in the +90°C to +100°C range. The diode should be selected to minimize reverse leakage at the maximum output voltage while minimizing forward losses when the diode is conducting.

Resistor (R2)

The current in resistor R2 is the same as the bleeding current for both zero cross and deep dimming. The source voltage is regulated at 0.5V. The current through R2 is given:

$$I_{R2} = 0.5/R2$$

Or the resistor value is dependent on the desired bleeding current by:

$$R2 = 0.5/I_{R2}$$

Typical Application Circuit

Boost for 50W MR16 Bulb Application

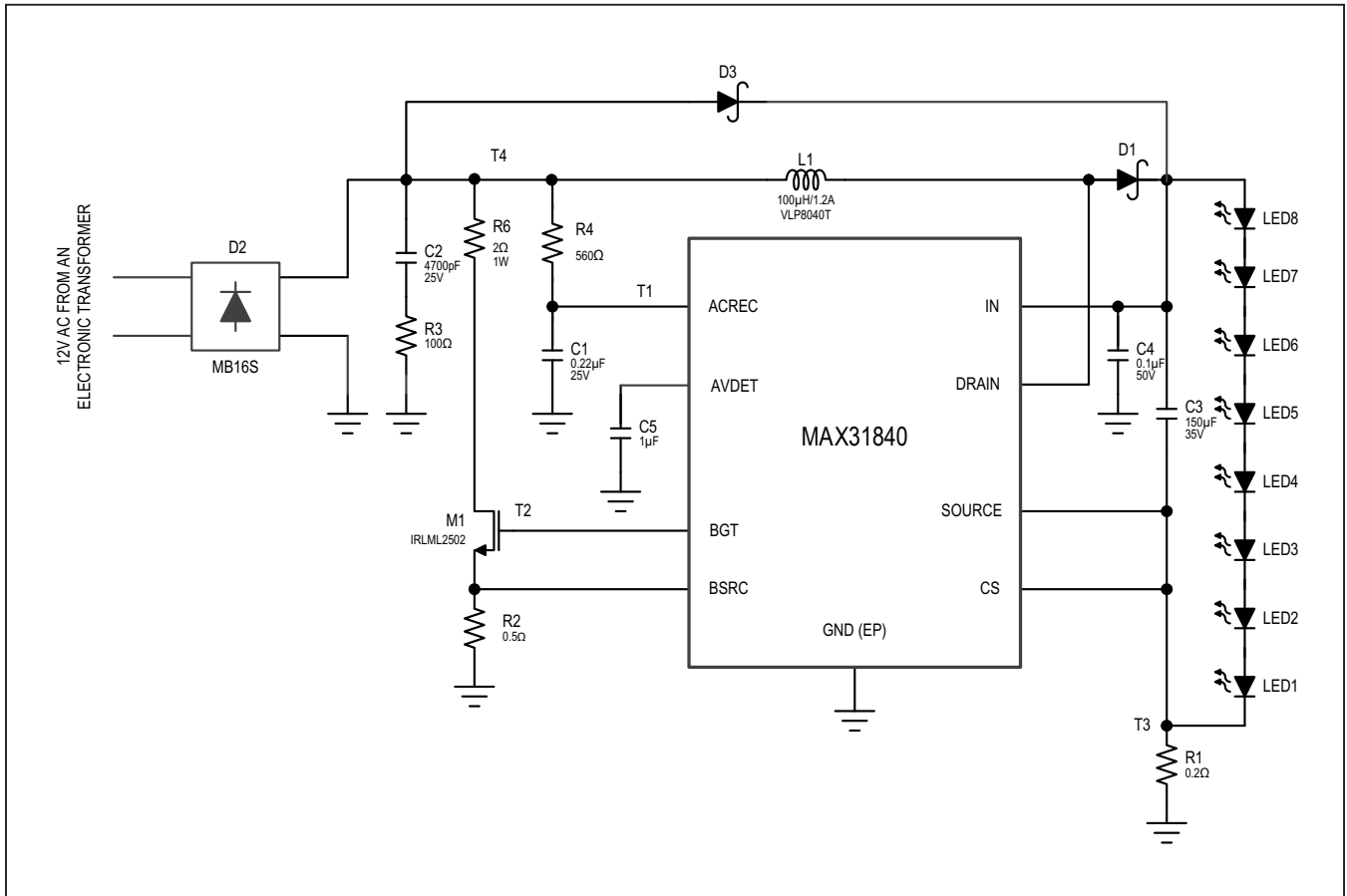

Ordering Information

PART NUMBER	TEMP RANGE	PIN-PACKAGE
MAX31840ATA+	-40°C to +125°C	8 TDFN-EP*

+Denotes a lead(Pb)-free/RoHS-compliant package.

*EP = Exposed pad.

MAX31840

MR16 LED Driver with Integrated Control
MOSFET and Deep Dimming

Revision History

REVISION NUMBER	REVISION DATE	DESCRIPTION	PAGES CHANGED
0	6/17	Initial release	—

For pricing, delivery, and ordering information, please contact Maxim Direct at 1-888-629-4642, or visit Maxim Integrated's website at www.maximintegrated.com.

Maxim Integrated cannot assume responsibility for use of any circuitry other than circuitry entirely embodied in a Maxim Integrated product. No circuit patent licenses are implied. Maxim Integrated reserves the right to change the circuitry and specifications without notice at any time. The parametric values (min and max limits) shown in the Electrical Characteristics table are guaranteed. Other parametric values quoted in this data sheet are provided for guidance.