

PANEL CUT OUT

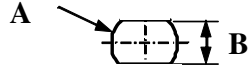

inches		
	Maxi	mini
A	.643	.637
B	.541	.535

REVISIONS			
REV.	DESCRIPTION	DATE	APPROVED
A	INITIAL RELEASE	04/23/18	D.N.

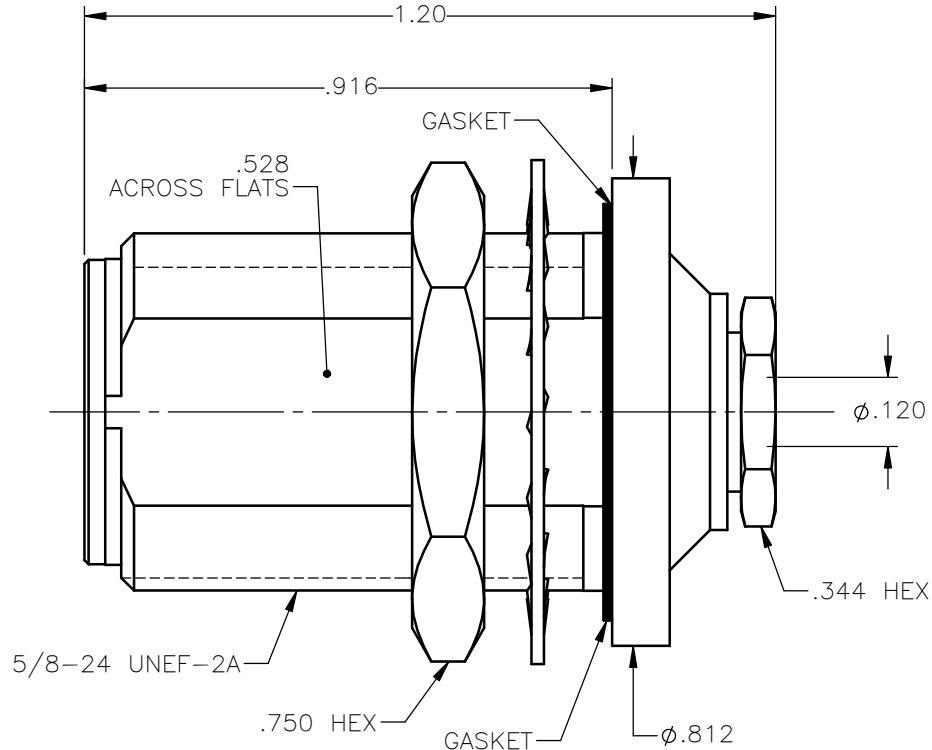



NOTES:

MATERIALS:

1. INSULATORS = VIRGIN WHITE TEFLON PER ASTM D1710, GRADE 1, TYPE I, CLASS "B".
2. CONTACT = BERYLLIUM COPPER PER ASTM B196, ALLOY C17300, TEMPER TD04.
3. GASKET = SILICONE RUBBER PER ZZ-R-765, CLASS 2B, GRADE 65-75.
4. LOCKWASHER = PHOSPHOR BRONZE PER ASTM B139, COPPER ALLOY C53400, TEMPER H04.
5. ALL OTHER METAL PARTS = BRASS PER ASTM B16, ALLOY C36000, TEMPER H02.

FINISHES:

1. CONTACT = GOLD PLATE PER ASTM B488-11, TYPE II, 50 μ in MIN, GRADE C, OVER 100 TO 200 μ in STRESS FREE SULFAMATE NICKEL PER AMS-QQ-N-290.
2. ALL OTHER METAL PARTS = GOLD PLATE PER ASTM B488-11, TYPE II, 30 μ in MIN, GRADE C OVER 100 TO 200 μ in COPPER STRIKE PER AMS 2418.

UNLESS OTHERWISE SPECIFIED DIMENSIONS ARE IN INCHES TOLERANCES ON	DWN:	DATE	 Property of Radiall This document cannot be reproduced or communicated to a third party without prior written permission of RADIALL.	
	D.N.	04/23/18		
DECIMAL	ANGLE	CHKD:	DATE	TYPE "N" JACK BULKHAD REAR MOUNT CLAMP TYPE FOR RG-316DS & SIMILAR CABLES
		C.E.	04/23/18	
		APVD:	DATE	SIZE A FSCM NO. 19505 DWG NO. 4501-1051-019 REV A
		J.M.	04/23/18	
REFERENCE:	MATERIALS & FINISHES:	SEE NOTES		SCALE 3:1 THIRD ANGLE PROJECTION
ORIGINATED: D.N. DATE: 04/23/18				SHEET 1 OF 1

4501-1051-019