

REVISIONS				
P.	LTN	DESCRIPTION	DATE	APVD
B1		REV PER ECO-12-015596	11OCT2012	RGV DCS
B2		REV PER ECO-19-000477	11JAN2019	DS DS

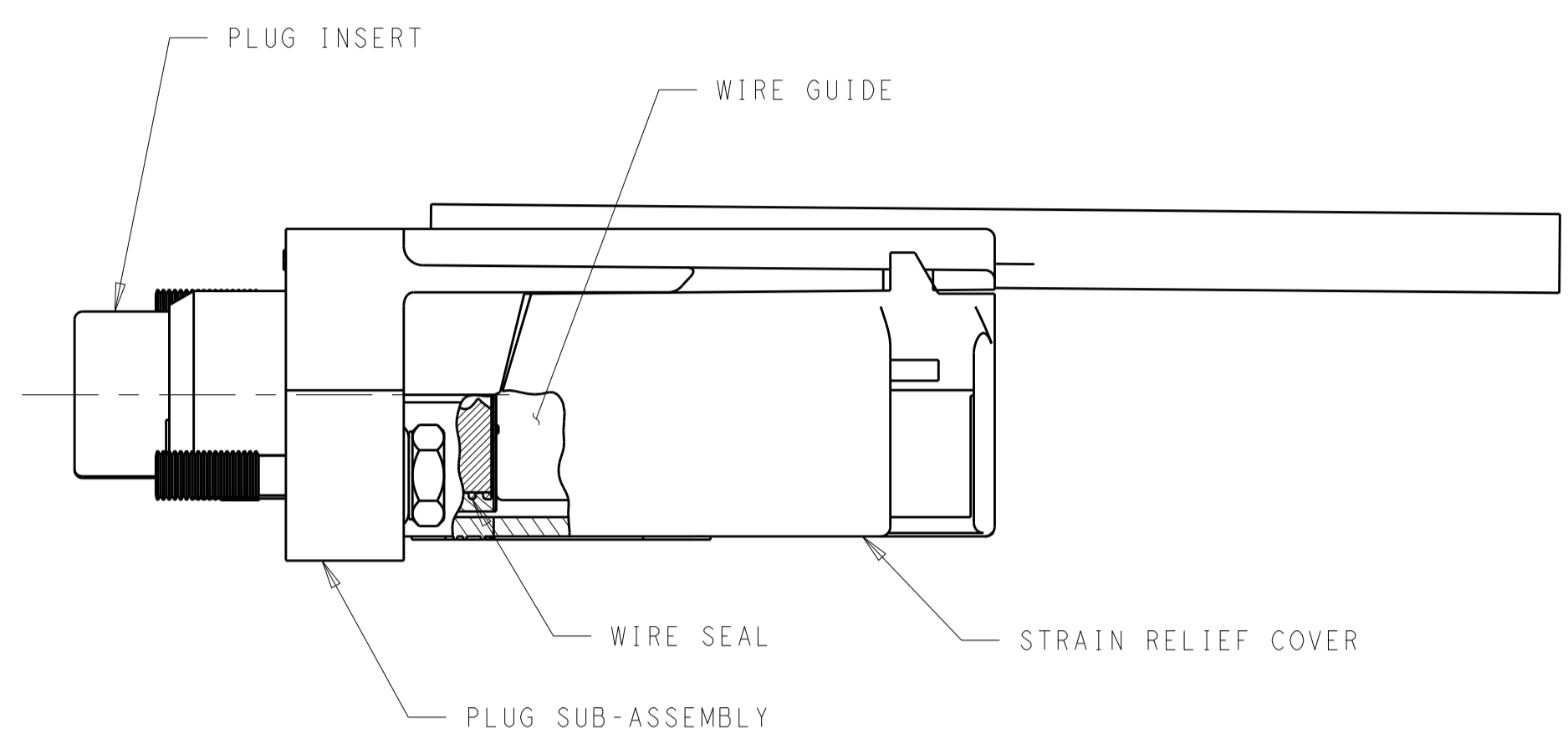

SECTION A-A

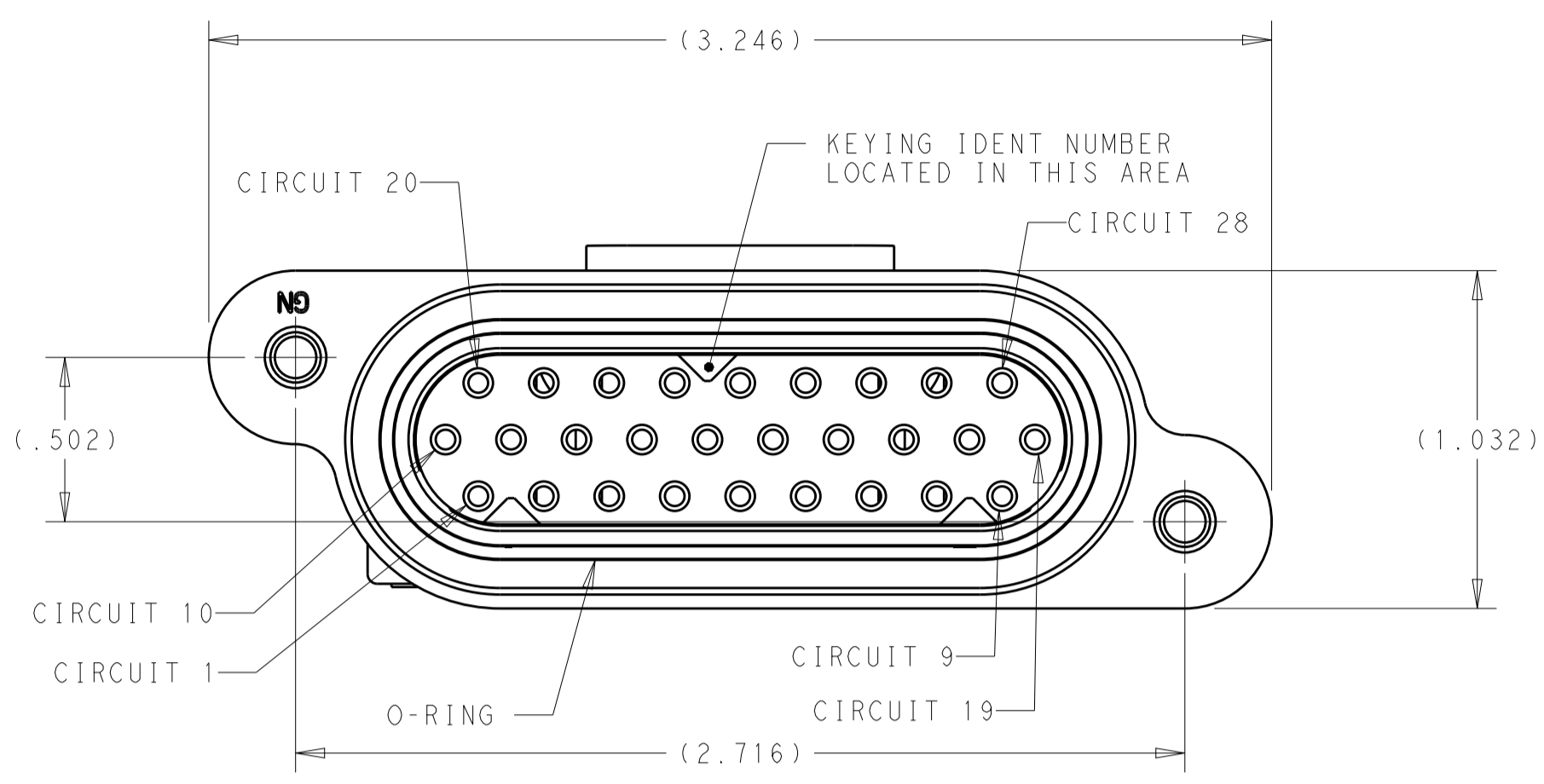
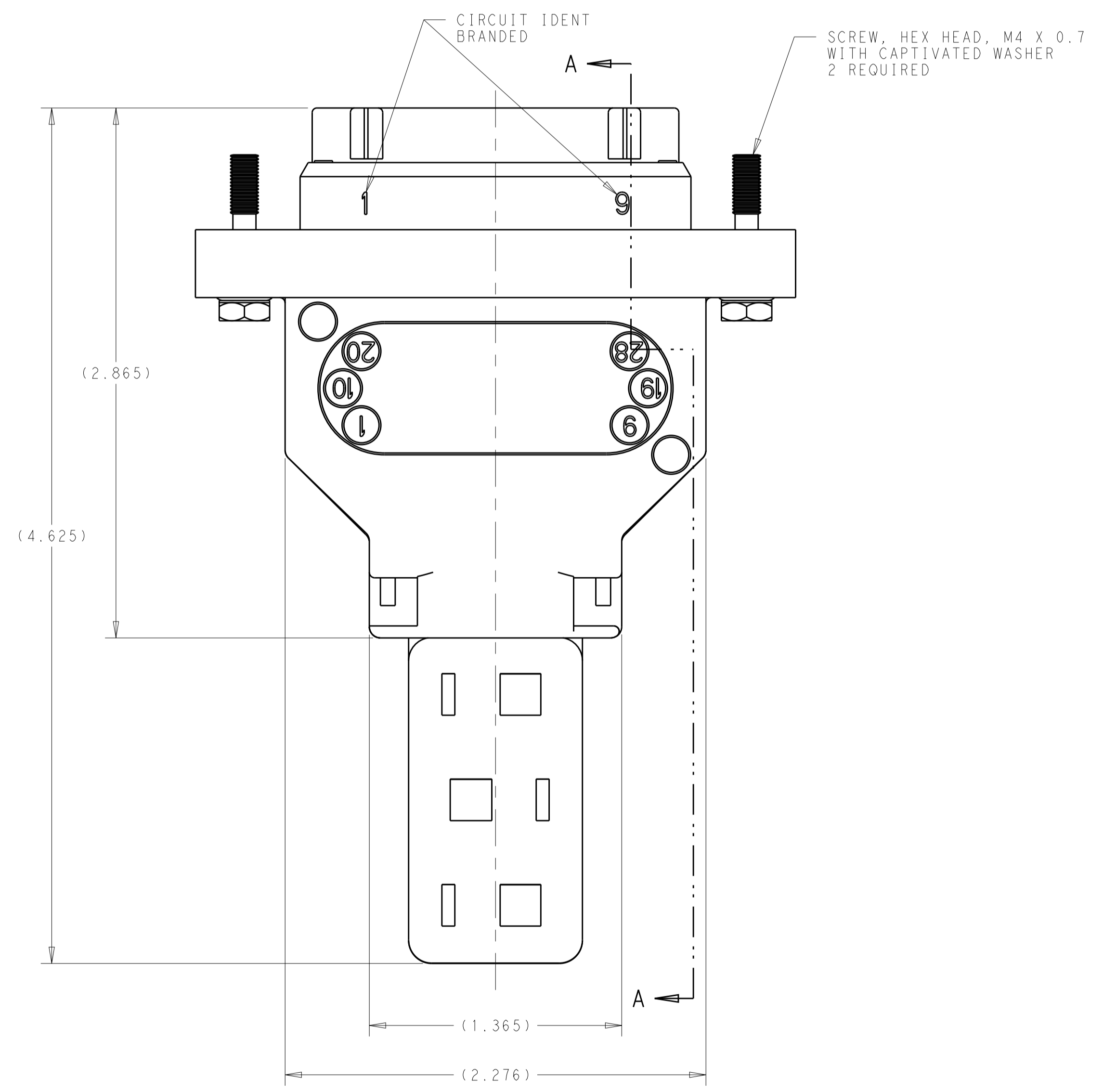

- ⚠ MATERIAL: PLUG SUB-ASSEMBLY - THERMOPLASTIC, BLACK
 PLUG INSERT - THERMOPLASTIC, BLACK
 WIRE SEAL - SILICONE RUBBER, GRAY
 SCREW AND WASHER - STAINLESS STEEL
 WIRE GUIDE - THERMOPLASTIC, BLACK
- PLUG ACCEPTS 28 SOCKET CONTACTS, PN 66773, WITH WIRE RANGE OF 18 - 16 AWG AND INSULATION RANGE 2.54 - 3.05 DIAMETER (NOT SUPPLIED, MUST BE ORDERED SEPARATELY).
 - PARTS MUST BE PACKAGED IN BULK KIT FORM.
 - CUMMINS ELECTRONICS MUST BE INFORMED BY WAY OF A PRODUCT CHANGE IDENTIFICATION OF ALL CHANGES TO THE TE CUSTOMER DRAWINGS.
 - MATES WITH HEADER ASSEMBLY, PN 213341.

776177-1	776104-1	212977-1	212982-1	776176-1	212984-7	770394-1	3614847	7		776179-7
776177-1	776104-1	212977-1	212982-1	776176-1	212984-6	770394-1	3614848	6		776179-6
776177-1	776104-1	212977-1	212982-1	776176-1	212984-5	770394-1	3049068	5		776179-5
776177-1	776104-1	212977-1	212982-1	776176-1	212984-4	770394-1	3049067	4		776179-4
776177-1	776104-1	212977-1	212982-1	776176-1	212984-3	770394-1	3048604	3		776179-3
776177-1	776104-1	212977-1	212982-1	776176-1	212984-2	770394-1	3048603	2		776179-2
776177-1	776104-1	212977-1	212982-1	776176-1	212984-1	770394-1	3048602	1		776179-1
WIRE GUIDE	O-RING	STRAIN RELIEF COVER	SCREW AND WASHER	WIRE SEAL	PLUG INSERT	PLUG SUB-ASSEMBLY	CUMMINS PART NUMBER	KEYING IDENT NO.	KEYING ARRANGEMENT	PART NUMBER

THIS DRAWING IS A CONTROLLED DOCUMENT.

APVD: D. STRAUSSER 13AUG2012

CHK: R. VESTAL 13AUG2012

NAME: PLUG KIT, WITH O-RING AND WIRE GUIDE, 28 POSITION, ECMSC CONNECTOR

SIZE: A100779 C=776179

SCALE: 2:1 SHEET 1 OF 1 REV B2

TE Connectivity