

END PANEL - NOT TO SCALE

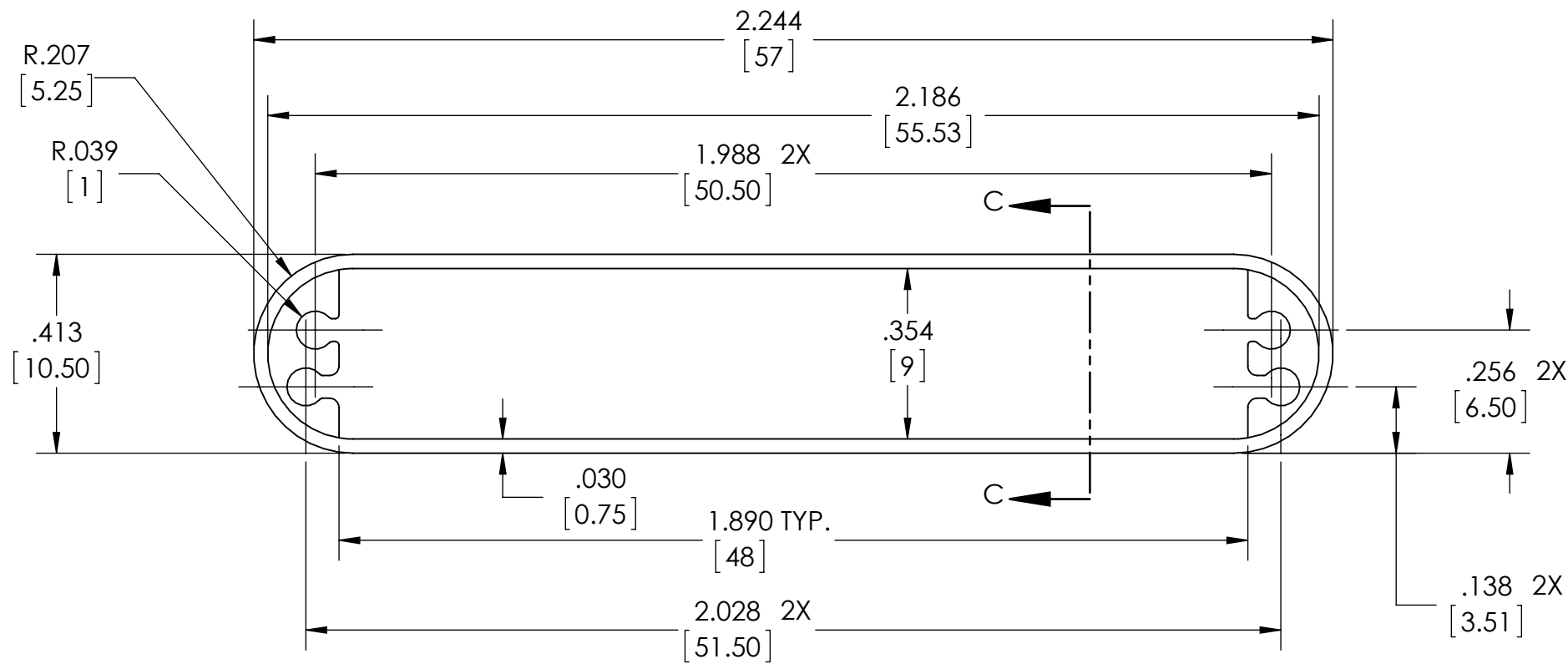

EXTRUSION PROFILE

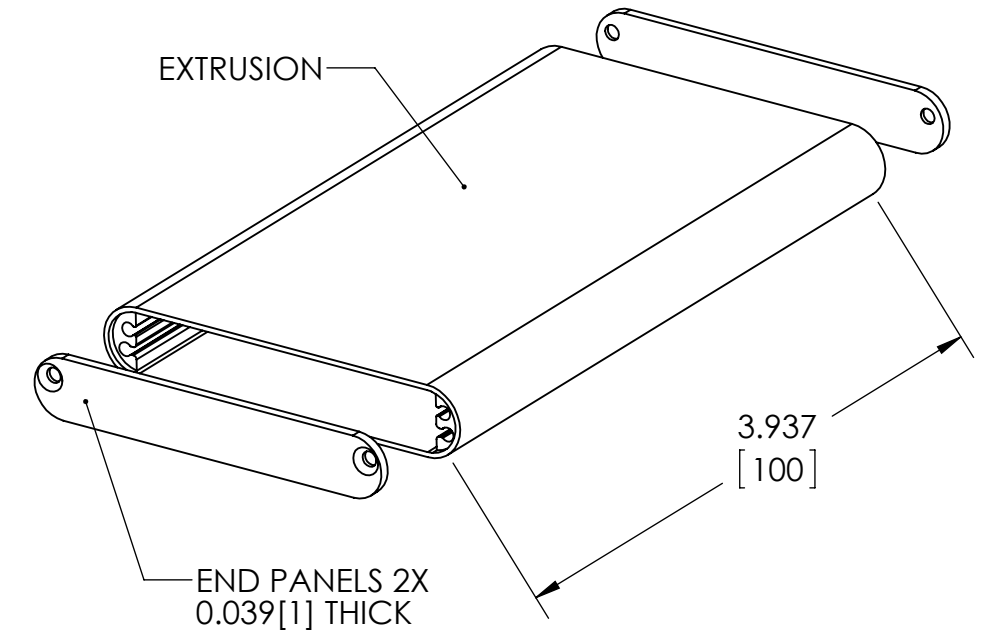
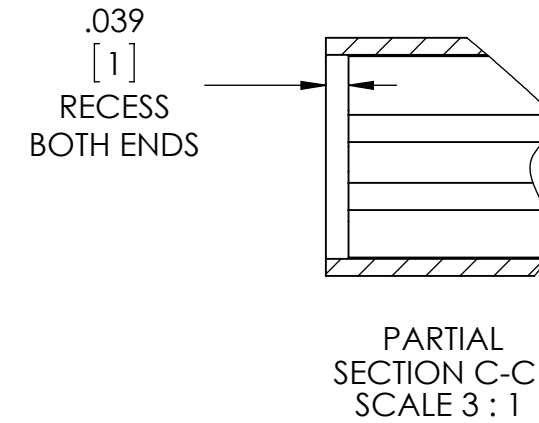

NOTES:

- 1- MATERIAL: EXTRUSION/END PANELS - ALUMINUM
- 2- FINISH: BLACK
- 3- DIMENSIONS ARE INCH[MM]
- 4- TOLERANCE ON PROFILE/END PANELS = +/- .020[.50]  
TOLERANCE ON CUT LENGTH = +/- .062[1.57]
- 5- SUPPLIED WITH TWO END PANELS AND FOUR M2 X 8mm STAINLESS STEEL - BLACK ZINC PLATE - FLATHEAD PHILLIPS SCREWS FOR MOUNTING THE PANELS