

Low-power dual voltage comparator

Datasheet - production data

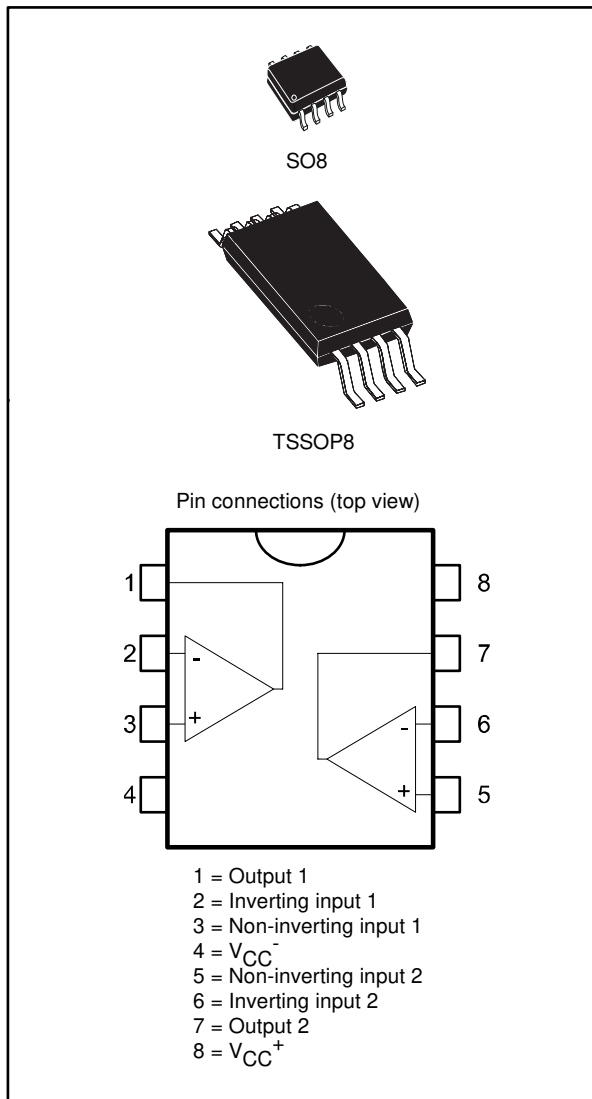

Features

- Wide single supply voltage range or dual supplies 2 V to 36 V or ± 1 V to ± 18 V
- Very low supply current (0.4 mA) independent of supply voltage (1 mW/comparator at 5 V)
- Low input bias current: 25 nA typ.
- Low input offset current: ± 5 nA typ.
- Input common-mode voltage range includes ground
- Low output saturation voltage: 250 mV typ. ($I_o = 4$ mA)
- Differential input voltage range equal to the supply voltage
- TTL, DTL, ECL, MOS, CMOS compatible outputs

Description

This device consists of two independent low power voltage comparators designed specifically to operate from a single supply over a wide range of voltages. Operation from split power supplies is also possible.

These comparators also have a unique characteristic in that the input common-mode voltage range includes ground even though operated from a single power supply voltage.

Contents

| | | |
|----------|--|-----------|
| 1 | Absolute maximum ratings and operating conditions | 3 |
| 2 | Circuit schematics..... | 4 |
| 3 | Electrical characteristics | 5 |
| 4 | Package information | 7 |
| | 4.1 SO8 package information..... | 8 |
| | 4.2 TSSOP8 package information..... | 9 |
| 5 | Ordering information..... | 10 |
| 6 | Revision history | 11 |

1 Absolute maximum ratings and operating conditions

Table 1: Absolute maximum ratings (AMR)

| Symbol | Parameter | Value | Unit | |
|------------|---|----------------|------|------|
| V_{CC} | Supply voltage | ± 18 or 36 | V | |
| V_{id} | Differential input voltage | ± 36 | | |
| V_{in} | Input voltage | -0.3 to 36 | | |
| | Output short-circuit to ground ⁽¹⁾ | 20 | mA | |
| R_{thja} | Thermal resistance junction to ambient ⁽²⁾ | SO8 | 125 | °C/W |
| | | TSSOP8 | 120 | |
| R_{thjc} | Thermal resistance junction to case ⁽²⁾ | SO8 | 40 | |
| | | TSSOP8 | 37 | |
| T_j | Maximum junction temperature | 160 | °C | |
| T_{stg} | Storage temperature range | -65 to 150 | | |
| ESD | HBM: human body model ⁽³⁾ | 800 | V | |
| | MM: machine model ⁽⁴⁾ | 200 | | |
| | CDM: charged device model ⁽⁵⁾ | 1500 | | |

Notes:

⁽¹⁾Short-circuit from the output to V_{CC}^+ can cause excessive heating and eventual destruction. The maximum output current is approximately 20 mA, independent of the magnitude of V_{CC}^+ .

⁽²⁾Short-circuits can cause excessive heating and destructive dissipation. Values are typical.

⁽³⁾Human body model: a 100 pF capacitor is charged to the specified voltage, then discharged through a 1.5 k Ω resistor between two pins of the device. This is done for all couples of connected pin combinations while the other pins are floating.

⁽⁴⁾Machine model: a 200 pF capacitor is charged to the specified voltage, then discharged directly between two pins of the device with no external series resistor (internal resistor < 5 Ω). This is done for all couples of connected pin combinations while the other pins are floating.

⁽⁵⁾Charged device model: all pins and the package are charged together to the specified voltage and then discharged directly to the ground through only one pin. This is done for all pins.

Table 2: Operating conditions

| Symbol | Parameter | Value | Unit |
|------------|---|--------------------------|------|
| V_{CC}^+ | Supply voltage | 2 to 36 | V |
| T_{oper} | Operating free-air temperature range | -40 to 150 | °C |
| V_{icm} | Input common mode voltage range ($V_{CC} = 30$ V), $T_{amb} = 25$ °C ⁽¹⁾ | 0 to (V_{CC+}) - 1.5 | V |
| | Input common mode voltage range ($V_{CC} = 30$ V), $T_{min} \leq T_{amb} \leq T_{max}$ ⁽¹⁾ | 0 to (V_{CC+}) - 2 | |

Notes:

⁽¹⁾The input common-mode voltage of either input signal voltage should not be allowed to go negative by more than 0.3 V. The upper end of the common-mode voltage range is (V_{CC}^+) - 1.5 V, but either or both inputs can go to 30 V without damage.

2 Circuit schematics

Figure 1: Schematic diagram (1/2 LM2903)

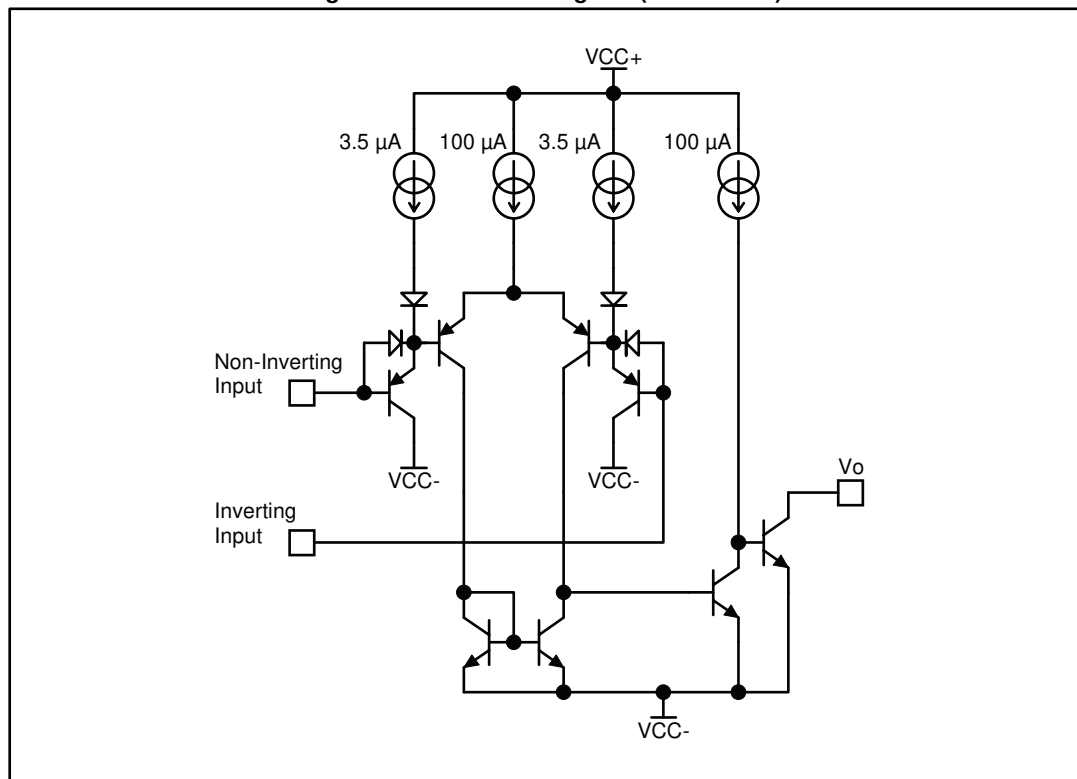

3 Electrical characteristics

Table 3: $V_{CC+} = 5\text{ V}$, $V_{CC-} = \text{GND}$, $T_{\text{amb}} = 25\text{ }^{\circ}\text{C}$ (unless otherwise specified),
 $T_{\text{min}} = -40\text{ }^{\circ}\text{C}$, and $T_{\text{max}} = 150\text{ }^{\circ}\text{C}$

| Symbol | Parameter | Min. | Typ. | Max. | Unit |
|-------------------|---|------|------|-------------------|---------------|
| V_{io} | Input offset voltage ⁽¹⁾ | | 1 | 7 | mV |
| | Input offset voltage, $T_{\text{min}} \leq T_{\text{amb}} \leq T_{\text{max}}$ | | | 15 | |
| I_{io} | Input offset current | | 5 | 50 | nA |
| | Input offset current, $T_{\text{min}} \leq T_{\text{amb}} \leq T_{\text{max}}$ | | | 150 | |
| I_{ib} | Input bias current ⁽²⁾ | | 25 | 250 | nA |
| | Input bias current, $T_{\text{min}} \leq T_{\text{amb}} \leq T_{\text{max}}$ | | | 400 | |
| A_{VD} | Large signal voltage gain, $(V_{\text{CC}^+}) = 15\text{ V}$, $R_{\text{L}} = 15\text{ k}\Omega$, $V_{\text{o}} = 1\text{ to }11\text{ V}$ | 25 | 200 | | V/mV |
| I_{CC} | Supply current, all comparators, $(V_{\text{CC}^+}) = 5\text{ V}$, no load | | 0.4 | 1 | mA |
| | Supply current, all comparators, $(V_{\text{CC}^+}) = 30\text{ V}$, no load | | 1 | 2.5 | |
| V_{id} | Differential input voltage ⁽³⁾ | | | V_{CC^+} | V |
| V_{OL} | Low level output voltage, $V_{\text{id}} = -1\text{ V}$, $I_{\text{sink}} = 4\text{ mA}$ | | 250 | 400 | mV |
| | Low level output voltage, $T_{\text{min}} \leq T_{\text{amb}} \leq T_{\text{max}}$ | | | 800 | |
| I_{OH} | High level output current, $(V_{\text{CC}^+}) = V_{\text{o}} = 30\text{ V}$, $V_{\text{id}} = 1\text{ V}$ | | 0.1 | | nA |
| | High level output current, $T_{\text{min}} \leq T_{\text{amb}} \leq T_{\text{max}}$ | | | 1 | μA |
| I_{sink} | Output sink current, $V_{\text{id}} = -1\text{ V}$, $V_{\text{o}} = 1.5\text{ V}$ | 6 | 16 | | mA |
| | Output sink current, $T_{\text{min}} \leq T_{\text{amb}} \leq T_{\text{max}}$ | 2 | | | |
| t_{re} | Small signal response time, $R_{\text{L}} = 5.1\text{ k}\Omega$ to (V_{CC^+}) ⁽⁴⁾ | | 1.3 | | μs |
| t_{rel} | Large signal response time, TTL input, $V_{\text{ref}} = 1.4\text{ V}$, $R_{\text{L}} = 5.1\text{ k}\Omega$ to (V_{CC^+}) , output signal at 50 % of final value ⁽⁵⁾ | | | 500 | ns |
| | Large signal response time, TTL input, $V_{\text{ref}} = 1.4\text{ V}$, $R_{\text{L}} = 5.1\text{ k}\Omega$ to (V_{CC^+}) , output signal at 50 % of final value ⁽⁵⁾ | | | 1 | μs |

Notes:

⁽¹⁾ At the output switch point, $v_{\text{o}} \approx 1.4\text{ V}$, $R_{\text{S}} = 0\text{ }\Omega$ with (V_{CC^+}) from 5 V to 30 V, and over the full input common-mode range (0 V to $(V_{\text{CC}^+}) - 1.5\text{ V}$).

⁽²⁾ The direction of the input current is out of the IC due to the PNP input stage. This current is essentially constant, independent of the state of the output, so there is no load charge on the reference of input lines.

⁽³⁾ Positive excursions of the input voltage may exceed the power supply level. As long as the other voltage remains within the common-mode range, the comparator will provide a proper output state. The low input voltage state must not be less than -0.3 V (or 0.3 V below the negative power supply, if used).

⁽⁴⁾ The response time specified is for a 100 mV input step with 5 mV overdrive.

⁽⁵⁾ Maximum values are guaranteed by design and evaluation.

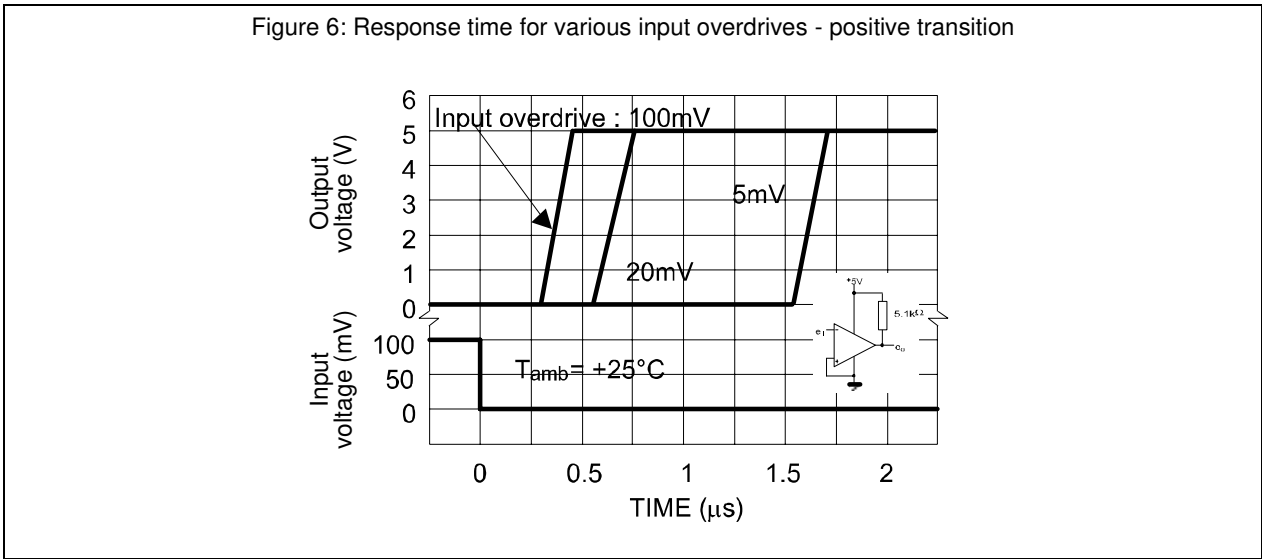
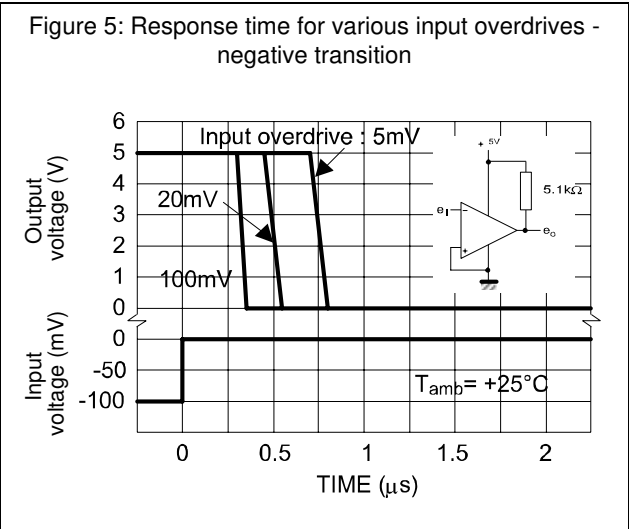
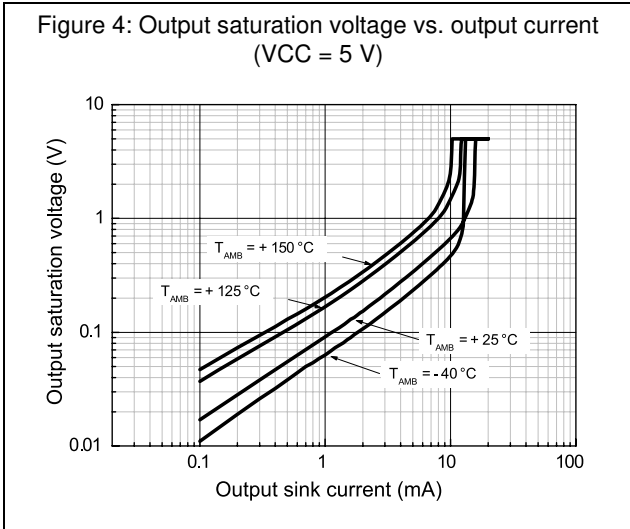
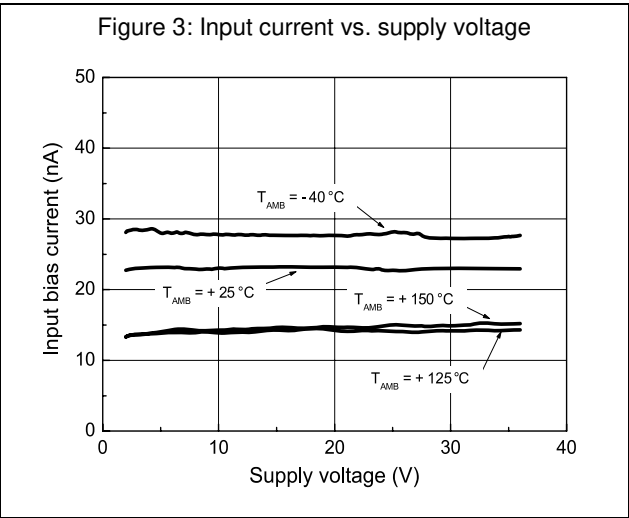
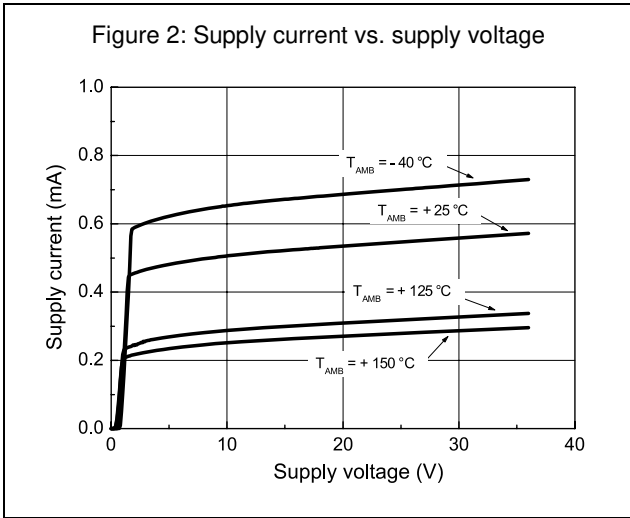

4 Package information

In order to meet environmental requirements, ST offers these devices in different grades of ECOPACK[®] packages, depending on their level of environmental compliance. ECOPACK[®] specifications, grade definitions and product status are available at: www.st.com. ECOPACK[®] is an ST trademark.

4.1 SO8 package information

Figure 7: SO8 package outline

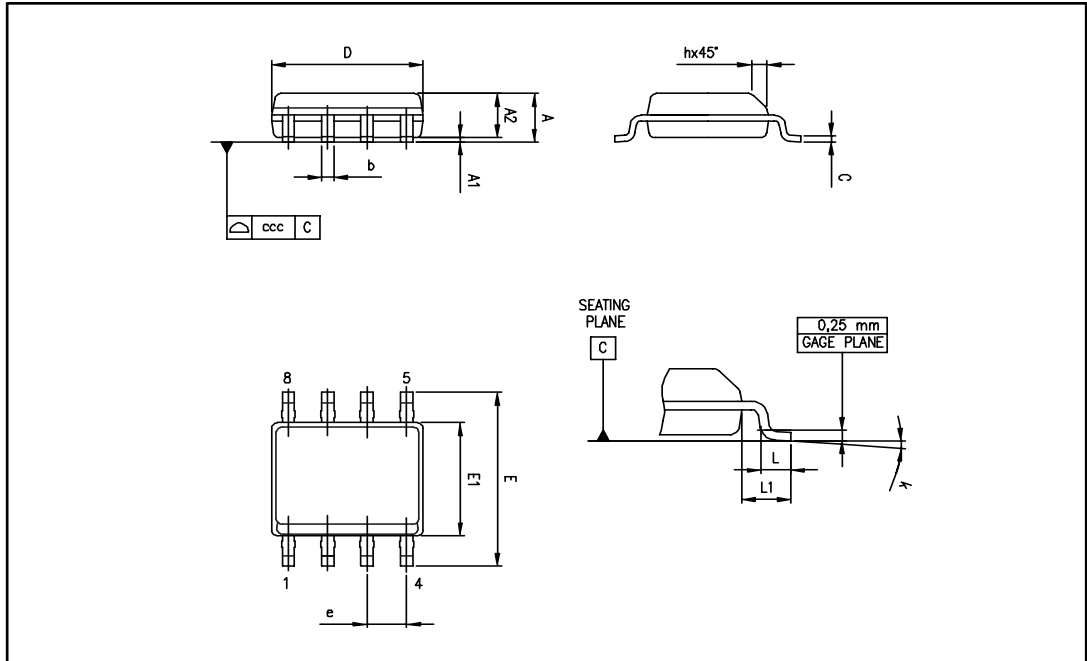

Table 4: SO8 mechanical data

| Ref. | Dimensions | | | | | |
|------|-------------|------|------|--------|-------|-------|
| | Millimeters | | | Inches | | |
| | Min. | Typ. | Max. | Min. | Typ. | Max. |
| A | | | 1.75 | | | 0.069 |
| A1 | 0.10 | | 0.25 | 0.004 | | 0.010 |
| A2 | 1.25 | | | 0.049 | | |
| b | 0.28 | | 0.48 | 0.011 | | 0.019 |
| c | 0.17 | | 0.23 | 0.007 | | 0.010 |
| D | 4.80 | 4.90 | 5.00 | 0.189 | 0.193 | 0.197 |
| E | 5.80 | 6.00 | 6.20 | 0.228 | 0.236 | 0.244 |
| E1 | 3.80 | 3.90 | 4.00 | 0.150 | 0.154 | 0.157 |
| e | | 1.27 | | | 0.050 | |
| h | 0.25 | | 0.50 | 0.010 | | 0.020 |
| L | 0.40 | | 1.27 | 0.016 | | 0.050 |
| L1 | | 1.04 | | | 0.040 | |
| k | 1° | | 8° | 1° | | 8° |
| ccc | | | 0.10 | | | 0.004 |

4.2 TSSOP8 package information

Figure 8: TSSOP8 package outline

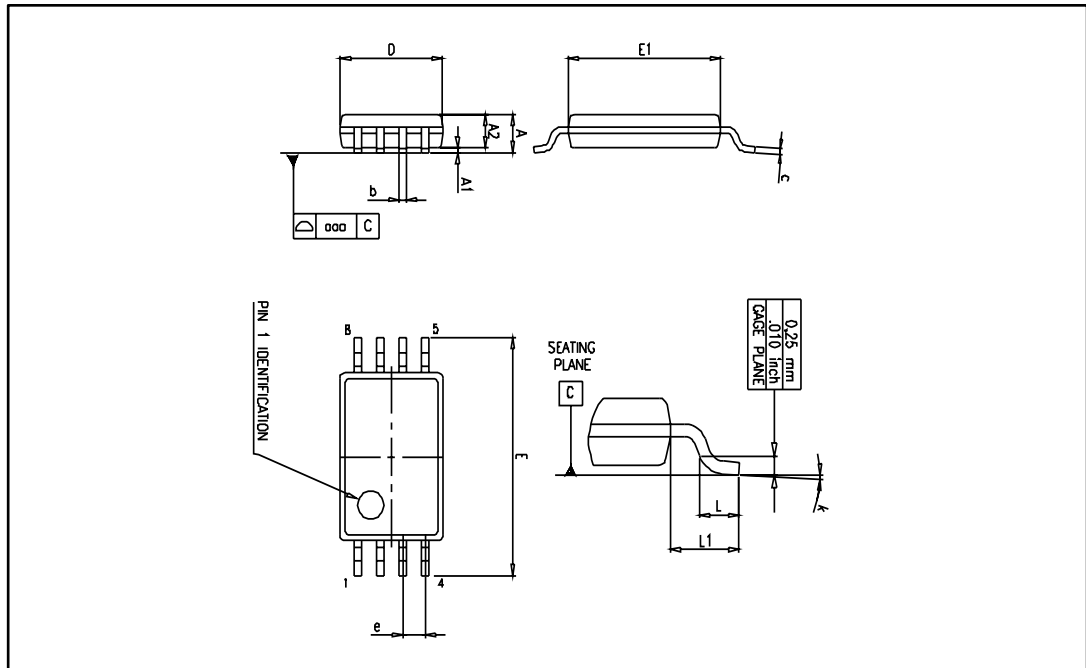

Table 5: TSSOP8 mechanical data

| Ref. | Dimensions | | | | | |
|------|-------------|------|------|--------|--------|-------|
| | Millimeters | | | Inches | | |
| | Min. | Typ. | Max. | Min. | Typ. | Max. |
| A | | | 1.2 | | | 0.047 |
| A1 | 0.05 | | 0.15 | 0.002 | | 0.006 |
| A2 | 0.80 | 1.00 | 1.05 | 0.031 | 0.039 | 0.041 |
| b | 0.19 | | 0.30 | 0.007 | | 0.012 |
| c | 0.09 | | 0.20 | 0.004 | | 0.008 |
| D | 2.90 | 3.00 | 3.10 | 0.114 | 0.118 | 0.122 |
| E | 6.20 | 6.40 | 6.60 | 0.244 | 0.252 | 0.260 |
| E1 | 4.30 | 4.40 | 4.50 | 0.169 | 0.173 | 0.177 |
| e | | 0.65 | | | 0.0256 | |
| k | 0° | | 8° | 0° | | 8° |
| L | 0.45 | 0.60 | 0.75 | 0.018 | 0.024 | 0.030 |
| L1 | | 1 | | | 0.039 | |
| aaa | | 0.1 | | | 0.004 | |

5 Ordering information

Table 6: Order codes

| Order code | Temperature range | Package | Packing | Marking |
|---------------------------|-------------------|---------------------------|---------------|---------|
| LM2903HYDT ⁽¹⁾ | -40 °C to 150 °C | SO8 (automotive grade) | Tape and reel | 2903HY |
| LM2903HYPT ⁽¹⁾ | | TSSOP8 (automotive grade) | | LM3H |

Notes:

⁽¹⁾ Qualified and characterized according to AEC Q100 and Q003 or equivalent, advanced screening according to AEC Q001 & Q 002 or equivalent.

6 Revision history

Table 7: Document revision history

| Date | Revision | Changes |
|-------------|----------|---|
| 25-Sep-2003 | 1 | Initial release. |
| 23-Aug-2005 | 2 | PPAP references inserted in the datasheet, see order codes table. |
| 27-Mar-2008 | 3 | Added ESD parameters in AMR table. Updated document format. |
| 13-Mar-2012 | 4 | Changed value of T_J in Table 1: Absolute maximum ratings (AMR). Removed LM2903HYD order code from Table 5. |
| 24-Sep-2015 | 5 | Added TSSOP8 package and new data related to it (Table 1: "Absolute maximum ratings (AMR)" and Table 6: "Order codes"). Removed obsolete wafer and all information pertaining to it (pad locations, order code). Table 6: "Order codes": removed obsolete order codes JLM2903H-E6D1, LM2903HD, and LM2903HDT. |
| 22-Oct-2015 | 6 | <i>Table 3</i> : modified title <i>Figure 2</i> , <i>Figure 3</i> , and <i>Figure 4</i> : corrected text of Y-axes |

IMPORTANT NOTICE – PLEASE READ CAREFULLY

STMicroelectronics NV and its subsidiaries ("ST") reserve the right to make changes, corrections, enhancements, modifications, and improvements to ST products and/or to this document at any time without notice. Purchasers should obtain the latest relevant information on ST products before placing orders. ST products are sold pursuant to ST's terms and conditions of sale in place at the time of order acknowledgement.

Purchasers are solely responsible for the choice, selection, and use of ST products and ST assumes no liability for application assistance or the design of Purchasers' products.

No license, express or implied, to any intellectual property right is granted by ST herein.

Resale of ST products with provisions different from the information set forth herein shall void any warranty granted by ST for such product.

ST and the ST logo are trademarks of ST. All other product or service names are the property of their respective owners.

Information in this document supersedes and replaces information previously supplied in any prior versions of this document.

© 2015 STMicroelectronics – All rights reserved