

CUSTOMER TERMINAL	RoHS	LEAD(Pb)-FREE
Sn96%, Ag4%	Yes	Yes



ELECTRICAL SPECIFICATIONS @ 25°C unless otherwise noted:

PARAMETER	TEST CONDITIONS	VALUE
D.C. RESISTANCE	2-4 @20°C	0.240 ohms ±10%
D.C. RESISTANCE	7-8 @20°C	3.50 ohms ±10%
D.C. RESISTANCE	9-10 @20°C	0.470 ohms ±10%
D.C. RESISTANCE	11-12 @20°C	1.35 ohms ±10%
INDUCTANCE	2-4 10kHz, 100mVAC, Ls	120uH ±10%
SATURATION CURRENT	2-4 20% rolloff from initial	650mA
LEAKAGE INDUCTANCE	2-4 tie(7+8+9+10+11+12), 100kHz, 100mVAC, Ls	2.5uH typ., 5.0uH max.
DIELECTRIC	2-7 tie(8+9+11), 625VAC, 1 second	-
DIELECTRIC	7-12 tie(8+9), 625VAC, 1 second	-
DIELECTRIC	7-10 625VAC, 1 second	-
TURNS RATIO	(7-8):(2-4)	3:1, ±1%
TURNS RATIO	(2-4):(9-10)	1.77:1, ±1%
TURNS RATIO	(2-4):(11-12)	1.77:1, ±1%

GENERAL SPECIFICATIONS:

OPERATING TEMPERATURE RANGE: -40°C to +125°C including temp rise.

Functional insulation only.

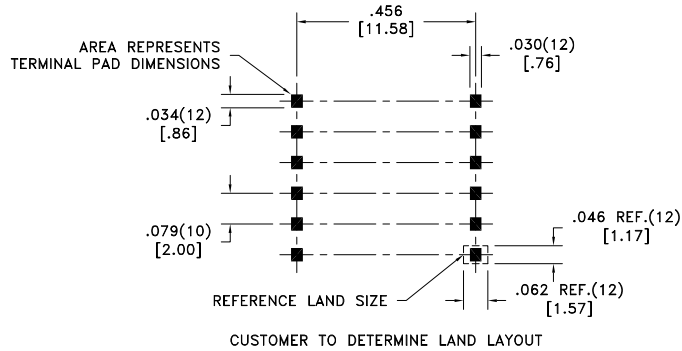
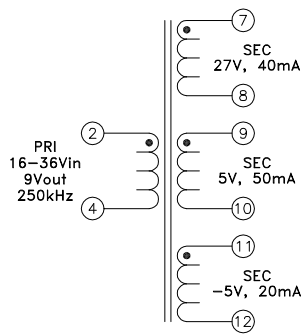
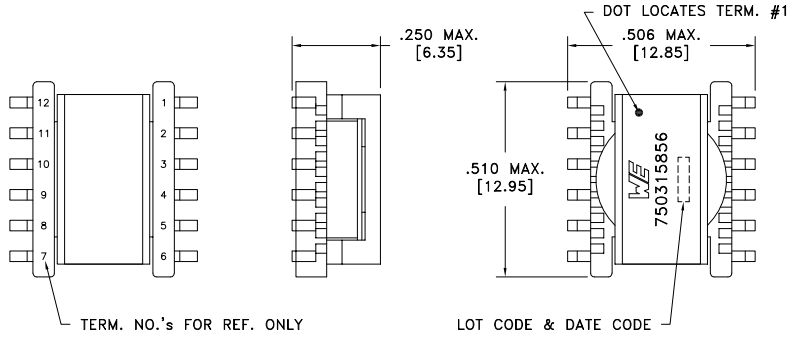

Wire insulation & RoHS status not affected by wire color.
Wire insulation color may vary depending on availability.

REV.	DATE	Packaging Specifications	CONVENTION PLACEMENT
		Method: Tape & Reel PKG-0757 www.we-online.com/midcom	
6B	11/18		
6A	4/16	SEE REVISION SHEET FOR REVISION LEVEL	

Tolerances unless otherwise specified:
Angles: ±1° Decimals: ±.005 [.13]
Fractions: ±1/64 Footprint: ±.005 [.13]

This drawing is dual dimensioned. Dimensions in brackets are in millimeters.

DRAWING TITLE
TRANSFORMER

eiSos p/n: 750315856

PART NO.
750315856

SPECIFICATION SHEET 1 OF 1

