

**Keyed-IO Cable-Board Connector System**

**1 SCOPE.**

**1.1 Content.**

This specification covers the performance, test and quality requirements for the Tyco Electronics Keyed-IO 8 pairs IO board and cable connector. The cable-plug-assembly is used to connect the cable to the board-connector.

**1.2 Qualification.**

When tests are performed on subject product, procedures specified in this Product Specification shall be used. All inspections shall be performed using applicable inspection plan and product drawing.

**1.3 Applicable partnumbers**

The partnumbers of subject products:

- X-1551451-x Keyed IO Cable Plug Assembly
- X-1551454-x Keyed IO Connector Assembly, version 1 (referred to as BCv1)
- X-1551967-x Keyed IO Connector Assembly, version 2 (referred to as BCv2)

**1.4 Completion**

Qualification of the Keyed IO Board Connector Assembly version 1 and version 2 have successfully been completed and are reported in the following Qualification Test Reports;

- Keyed IO version 1: 501-19170
- Keyed IO version 2: 501-19179

This documentation is on file and available from Engineering Practices and Standards (EPS).

**2 Applicable Documents.**

The following documents form a part of this specification to extend specified herein. Unless otherwise specified, latest edition of the document applies. In the event of conflict between the requirements in this specification and the product drawing, product drawing shall take precedence. In the event of conflict between requirements of this specification and referenced documents, this specification shall take precedence.

**2.1 Tyco Documents.**

- 501-19170 Test report. Cable/Board Keyed-IO Connector assy (version 1)
- 501-19179 Test report. Cable/Board Keyed-IO Connector assy (version 2)
- 114-19132 Application specification Keyed-IO Cable/Board Connector System.

**2.2 Other Documents.**

- IEC 60512 Basic testing procedures and measuring methods for electromechanical components for electronic equipment.

J. Smits

DATE 10 JUL 2012

T de Boer

DATE 10 JUL 2012

### **3 Requirements:**

#### **3.1 Design and Construction.**

Products shall be of design, construction and physical dimensions as specified on the applicable customer product drawings C-1551451 (Cable Connector), C-1551454 (Board Connector version 1) and C-1551967 (Board Connector version 2).

#### **3.2 Materials and Finish.**

Materials used in the construction of this product shall be as specified on the applicable customer drawing.

#### **3.3 Ratings**

- A. Operating voltage - 30 Volt DC max
- B. Impedance - 100 Ohm
- B. Current - 0,7 Amp max (position 14 and 20), 0,5 Amp max. (other positions)
- C. Operating temperature - -55°C to 105°C.
- D. Durability - 100 cycles.

**3.4 Performance and Test Description.**

The product is designed to meet mechanical and environmental performance specified in this paragraph as tested per test sequence specified in Para 3.5.

Unless otherwise specified, all tests are performed at ambient environmental conditions per IEC specification 60068-1 clause 5.3 and are performed with connectors in mated condition.

VISUAL			
Para	Test Description	Performance Requirements or Severity	Procedures
3.4.1	Examination of product	Meets requirements of product Drawing and applicable instructions on customer drawing, instruction sheet, application specification.	Visual, dimensional and functional per applicable inspection plan.

ELECTRICAL			
Para	Test Description	Performance Requirements or Severity	Procedures
3.4.2	Termination resistance Board connector – Cable connector (signal and ground)	Max. open voltage 20mV. Max. current 100 mA DC. All contacts to be measured. Measuring points shall be as indicated in fig.1  Requirement: 30 mΩ max. (Initial; exclusive bulk) 40 mΩ max. (Final; exclusive bulk)	In acc. With IEC 60512-2-1
3.4.3	Termination resistance Board connector – Cable connector (shield)	Max. open voltage 20mV. Max. current 100 mA DC. All contacts to be measured. Measuring points shall be as indicated in fig.2  Requirement: 10 mΩ max. (Initial; exclusive bulk) 20 mΩ max. (Final; exclusive bulk)	In acc. With IEC 60512-2-1
3.4.4	Insulation resistance	Test voltage 100V . Duration: 1 minute. Test between adjacent contacts.  Requirement: 10 <sup>3</sup> MΩ min.	In acc. with IEC 60512-3-1
3.4.5	Voltage proof	Test voltage 300 VDC for adjacent contacts. Duration 1 minute.  Requirement: no break-down or flash-over.	In acc. with IEC 60512-4-1
3.4.6	Current temperature de-rating curve	Temperature rise: 30°C maximum over ambient temperature (65°C) at 0,7A on positions 14 and 20, 0,5A on all other positions.	In acc. with IEC 60512-5-2 / test 5b

MECHANICAL			
Para	Test Description	Performance Requirements or Severity	Procedures
3.4.10	Signal Contact spring force	Min. 0,5N	At deflection of 0.165 mm.
3.4.11	Shielding Contact spring force	Min. 2,5N	At required deflection to reach dimension A (see figure 5).
3.4.14	Vibration	10-500 Hz sweeping 1 oct./min., displacement 0,75mm peak/accel. 10 g , 30 minutes in each of 3 mutual perpendicular axes.  Requirement: No Physical damage. No discontinuity > 1 μsec.	In acc. with IEC 60068-2-6
3.4.15	Physical shock	Subject connector to 50 g half sine shock pulses of 11 ms duration. 6 shocks in two directions of 3 mutual perpendicular axes.	In acc. with IEC 60512-6-3
3.4.17	Mate / un-mate forces without latch.	Mate and un-mate connector-pair. Speed: 2 mm/sec. rest 30 sec min.  Requirement: Total mating force 50 N max. Total un-mating force 10 N min to 40 N max.	In acc. with IEC 60512-13-2
3.4.18	Mechanical operation (Inclusive latch)	Mate and un-mate specimens for 100 cycles at a maximum rate of 500 cycles per hour with cage latch operable at room conditions.	In acc. With IEC 60512-9-1
3.4.19	Side-load in 4 directions (up-down-right-left)	Cable connector mated on board connector.  BCv1: Apply 40N on cable connector in every direction (individually) (at 27mm from edge of pcb), during 10 seconds. (see figure 4)  BCv2: Apply 60N on cable connector in every direction (individually) (at 27mm from edge of pcb), during 10 seconds. (see figure 4)  Requirement: No functional damage, latch should be in place.	In acc. with IEC 60512-17-3
3.4.20	Locking latch strength	Apply 100 N straight force at the mated cable connector, in un-mating direction.  Requirement: No functional damage, cable plug shall not unmate.	In acc. with IEC 60512-15-1
3.4.21	Rotational pull force (not applicable for BCv1)	Load cabled module into board-connector. Apply an axial pull-force of 40N on the cable, the pull-force will be in a 33 degrees angle with the axial direction of the connector. Rotate the load 3 full rotations (1080 degrees) with respect to the axial direction of the connector.  Requirement: plug shall remain mated with no evidence of housing damage.	In acc. with IEC 60512-15-1

SIGNAL INTEGRITY			
Para	Test Description	Performance Requirements or Severity	Procedures
3.4.30	Characteristic Impedance	Time Domain (TDR) measurement Impedance profile : the test board, PCB cable connector and 1000ps cable Risetime of incident pulse : 1ns (20%-80%) Pairs 15-16 and 18-19  Requirement : 100 Ω +/- 10%	In accordance with IEC 60512-25-7
3.4.31	Delay skew	Max 450ps/m asymmetry between pairs.	Measurements to be performed on 0,9m cable assemblies.
3.4.33	Insertion Loss	Frequency Domain (FDT) S-parameter measurement Pairs 15-16 and 18-19 Samples : 0,9m with AWG28  Requirement: Max 0,2db at 10MHz	In accordance with IEC 61156-1
3.4.36	Screening Attenuation	Requirement : < -40dB at 0 to 1GHz for cable assembly and PCB connector Measurements to be performed on 0,9m cable assemblies	In accordance with IEC 62153-4-4 / IEC 62153-4-7

ENVIRONMENTAL			
Para	Test Description	Performance Requirements or Severity	Procedures
3.4.40	Rapid change of Temperature	-40°90°C, 0,5 hrs / 0,5 hrs, 5 cycles	In acc. with IEC 60512-11-4
3.4.41	Climatic sequence Dry heat 1 <sup>st</sup> Damp heat cycle Cold 2 <sup>nd</sup> Damp heat cycle	90°C, 16 hrs 25°55°C, RH 93%, 24 hrs -40°C, 2 hrs 25°55°C, RH 93%, 24 hrs	In acc. with IEC 60512-11-1
3.4.42	Damp/heat steady state	Temperature 40°C, RH 93%, Duration: 21 days	In acc. with IEC 60512-11-3
3.4.43	Temperature life.	Subject mated specimens to 105°C for 240 hours without electrical load.	In acc. with IEC 60512-11-9
3.4.44	Corrosion mixed flowing gas	Temperature 25°C, RH 75%, Cl <sub>2</sub> 10 ppb, NO <sub>2</sub> 200 ppb, H <sub>2</sub> S 10 ppb, SO <sub>2</sub> 200 ppb. Duration: 20 days (board-connector only)	In acc. with IEC 60512-11-7
3.4.45	Resistance to soldering heat board connector	Specimens were subject to the following reflow profile. (see figure 3)	Tyco 109-201, method C

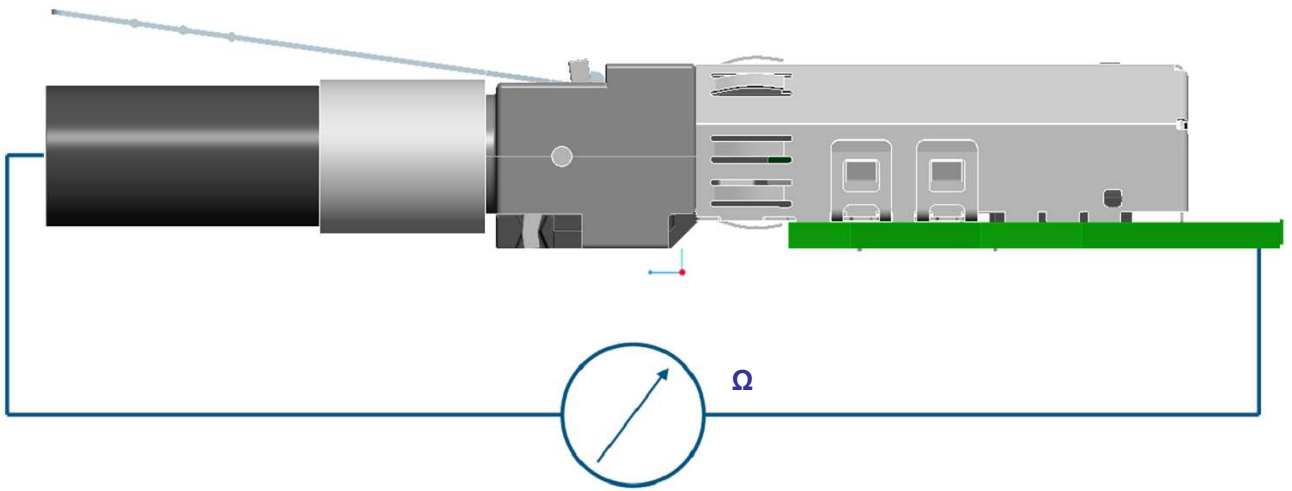

Figure 1

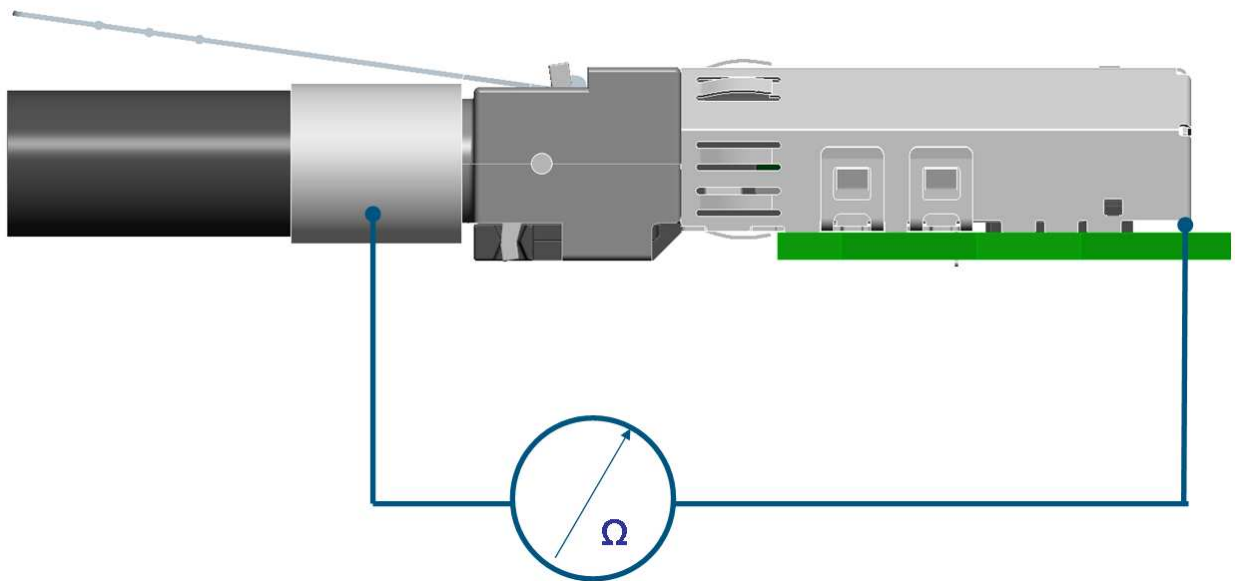

Figure 2

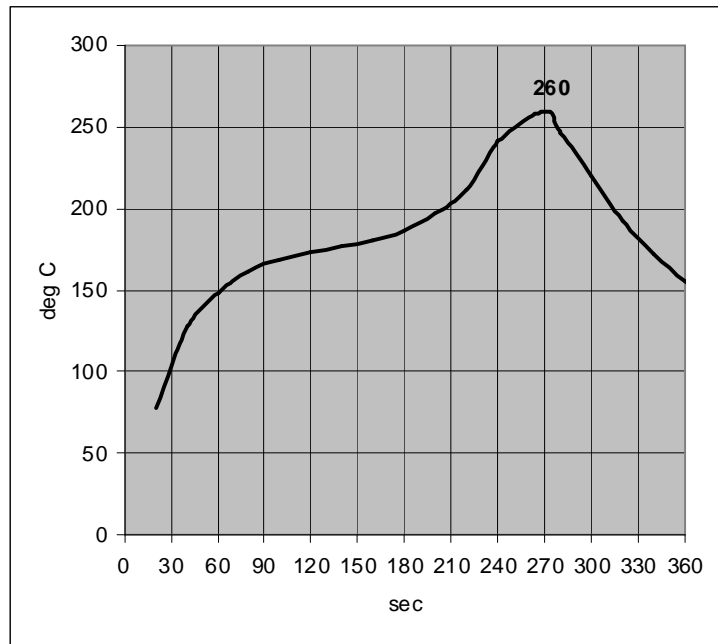

Figure 3

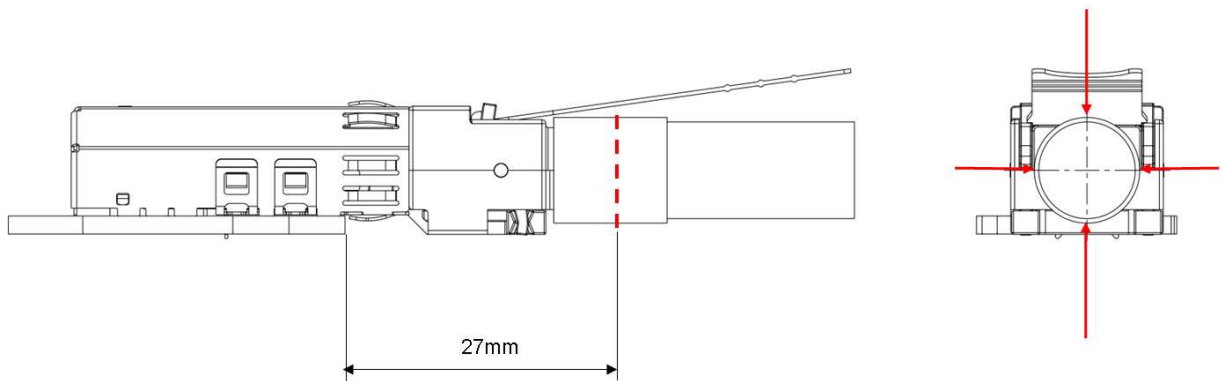

Figure 4

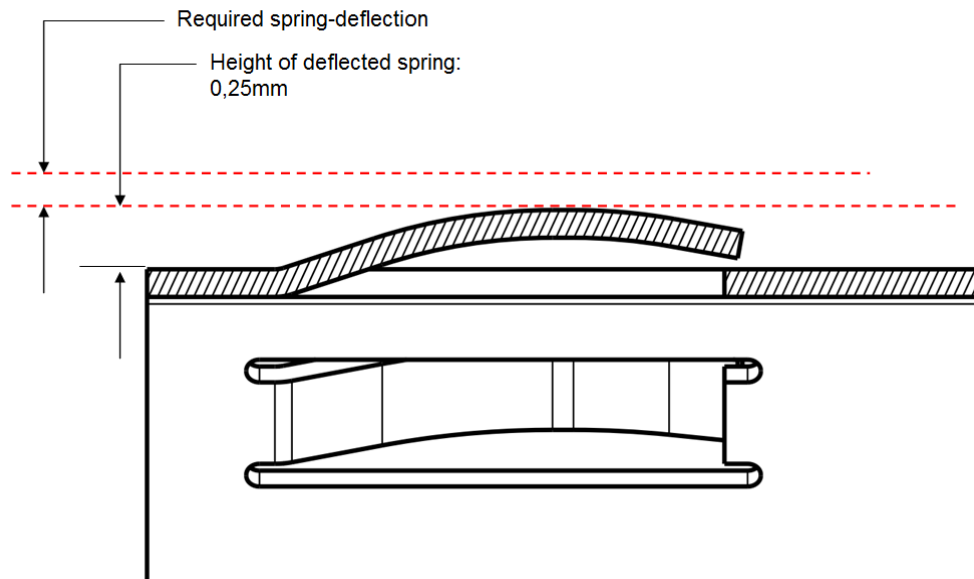

Figure 5



**3.5 Product Qualification and Requalification Test Sequence**

**3.5.1 Test sequence applicable for Keyed IO connector assembly version 1**

test or examination	paragraph	Testgroup (a)							
		1	2	3	4	5	6	7	8
		Test-sequence (b)							
Examination of product	3.4.1	1, 8	1, 10	1, 13	1, 8	1, 22	1,7	1, 5	1, 3
Termination resistance board connector - cable connector (signal and ground)	3.4.2	2, 6	2, 5, 8	2, 5, 8, 11	2, 6	2, 7, 12, 17, 20			
Termination resistance board connector - cable connector (shield)	3.4.3	3, 7	3, 6, 9	3, 6, 9, 12	3, 7	3, 8, 13, 18, 21			
Insulation resistance	3.4.4					4, 9, 14			
Voltage proof	3.4.5					5, 10, 15			
Current temperature derating curve	3.4.6	4							
Signal Contact spring force	3.4.10						2,5		
Shield contact spring force	3.4.11						3,6		
Vibration	3.4.14				4				
Physical shock	3.4.15				5				
Mate / unmate force without latch	3.4.17	5							
Mechanical operation (half of numbers)	3.4.18			4, 10					
Side-load in 4 directions	3.4.19		4						
Locking latch strength	3.4.20		7						
Rotational pull force	3.4.21	n.a.	n.a.	n.a.	n.a.	n.a.	n.a.	n.a.	n.a.
Rapid change of temperature	3.4.40					6			
Climatic sequence	3.4.41					11			
Damp/heat steady state	3.4.42					16			
Temperature life	3.4.43					19			
Corrosion mixed flowing gas (board- connector)	3.4.44			7					
Resistance to soldering heat (board- connector)	3.4.45						4		
Characteristic impedance	3.4.30							2	
Delay Skew	3.4.31							3	
Insertion loss	3.4.33							4	
Screening attenuation	3.4.36								2

(a) See paragraph 4.1

(b) Numbers indicate sequence in which tests are performed

3.5.2 Test sequence applicable for Keyed IO connector assembly version 2

test or examination	paragraph	Testgroup (a)							
		1	2	3	4	5	6	7	8
		Test-sequence (b)							
Examination of product	3.4.1	1, 8	1, 13	1, 13	1, 8	1, 22	1,7	1, 5	1, 3
Termination resistance board connector - cable connector (signal and ground)	3.4.2	2, 6	2, 5, 8, 11	2, 5, 8, 11	2, 6	2, 7, 12, 17, 20			
Termination resistance board connector - cable connector (shield)	3.4.3	3, 7	3, 6, 9, 12	3, 6, 9, 12	3, 7	3, 8, 13, 18, 21			
Insulation resistance	3.4.4					4, 9, 14			
Voltage proof	3.4.5					5, 10, 15			
Current temperature derating curve	3.4.6	4							
Signal Contact spring force	3.4.10						2,5		
Shield contact spring force	3.4.11						3,6		
Vibration	3.4.14				4				
Physical shock	3.4.15				5				
Mate / unmate force without latch	3.4.17	5							
Mechanical operation (half of numbers)	3.4.18			4, 10					
Side-load in 4 directions	3.4.19		4						
Locking latch strength	3.4.20		7						
Rotational pull force	3.4.21		10						
Rapid change of temperature	3.4.40					6			
Climatic sequence	3.4.41					11			
Damp/heat steady state	3.4.42					16			
Temperature life	3.4.43					19			
Corrosion mixed flowing gas (board- connector)	3.4.44			7					
Resistance to soldering heat (board- connector)	3.4.45						4		
Characteristic impedance	3.4.30							2	
Delay Skew	3.4.31							3	
Insertion loss	3.4.33							4	
Screening attenuation	3.4.36								2

(a) See paragraph 4.1

(b) Numbers indicate sequence in which tests are perform

**4 QUALITY ASSURANCE PROVISIONS.****4.1 Qualification Testing.****Sample Selection.**

Samples shall be prepared in accordance with applicable instructions and shall be selected random from current production.

Unless details to perform test require otherwise, plugs shall be terminated on cables according to applicable instructions and requirements specified in appropriate Application Specification and Instruction Sheet.

Unless otherwise specified all test groups shall consist of a minimum of 5 connectors of applicable type. Qualification inspection shall be verified by testing samples as specified in Para 3.5.

**4.2 Requalification Testing.**

If changes significantly affecting form, fit or function are made to product or manufacturing process, product assurance shall coordinate re-qualification testing, consisting of all or part of original testing sequence as determined by product, quality and reliability engineering.

**4.3 Acceptance.**

Acceptance is based on verification that product meets requirements of Para 3.4. Failures attributed to equipment, test set-up, test sub-components or operator deficiencies shall not disqualify the product. When product failure occurs, corrective action shall be taken and samples resubmitted for qualification. Testing to confirm corrective action is required before re-submittal.

**4.4 Quality Conformance Inspection.**

Applicable Tyco Electronics quality inspection plan will specify sampling acceptable quality level to be used. Dimensional and functional requirements shall be in accordance with applicable product drawing and this specification.