

DIT IS ONZE EIGENDOM EN MAG NOCH NAGEMAAKT, HERDRUKT, OVERGEMAAKT AAN DERDEN, NOCH VOOR FABRIKATIE GEBRUIKT WORDEN, ZONDER ONZE SCHRIFTELIJKE TOELATING. BIJ NIET GEBRUIK IS DE TERUGZENDING VERPLICHT.

THIS IS OUR EXCLUSIVE PROPERTY. IT IS NOT TO BE COPIED, REPRINTED OR DISCLOSED TO A THIRD PARTY. NOR USED FOR MANUFACTURING WITHOUT OUR WRITTEN CONSENT, AND HAS TO BE RETURNED TO US IN CASE OF NO USAGE

REV.	DATE	DESCRIPTION	BY	C'K'D'
01	03-09-92	CAV. DIA. ENLARGED	Y.D.	
02	10-03-99	CONVERSION ME10	K.N.	
03	10-03-99	TEMPERATURE RANGE -55C INSTEAD OF -25C	K.N.	
04	12-01-05	ADD O-RING AT THE REAR	R Ch	

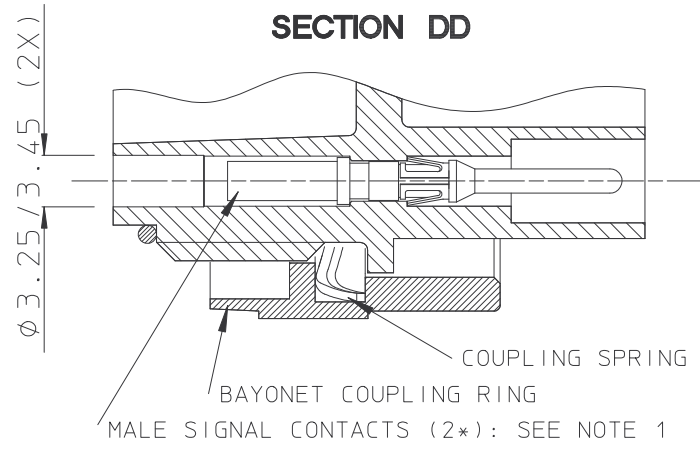
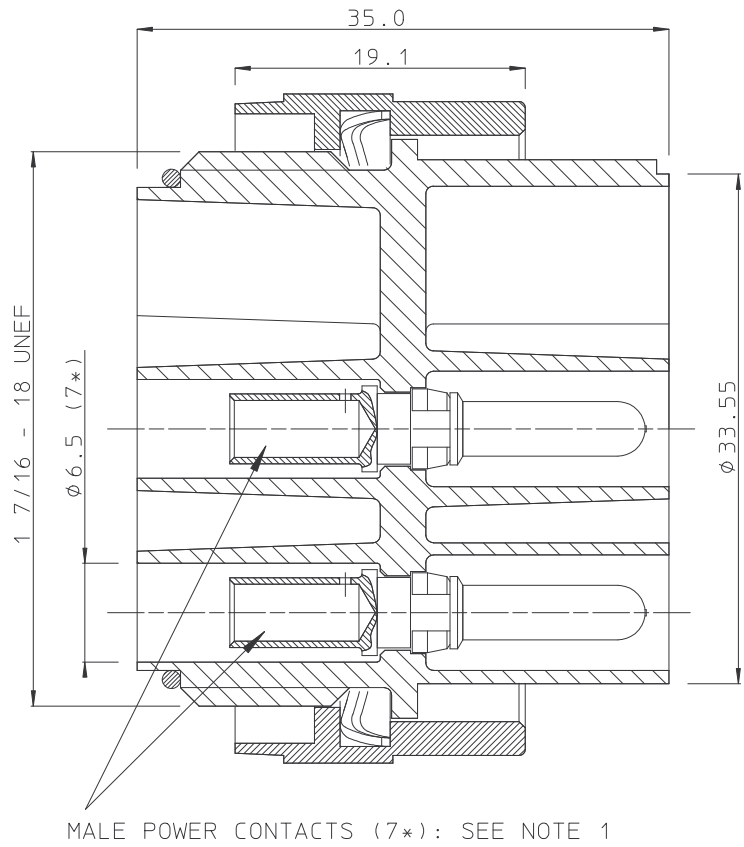
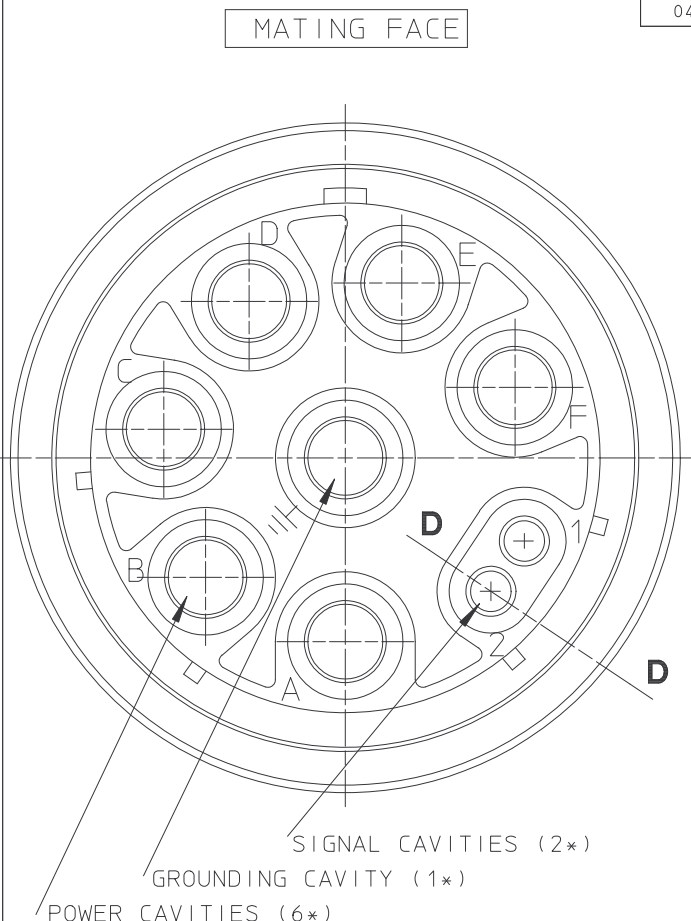

**PERFORMANCE CHARACTERISTICS**

- OPERATING TEMPERATURE : -55 °C TO +125 °C.
- INSULATION RESISTANCE : 5000 Mohm MIN.
- TEST POTENTIAL : 2000 V EFF.
- CONNECTOR AS PER VDE 0110 GROUP C 660V

**MATERIAL**

- BODY : GLASS-FILLED POLYESTER UL94-V0. COLOUR : BLACK.
- BAYONET COUPLING RING : HIGH STRENGTH CuZn ALLOY, NICKEL PLATED.
- COUPLING SPRING: SPRING STEEL

**NOTES**

1. CONTACTS TO BE ORDERED SEPARATELY
2. FOR ADDITIONAL INFORMATION REFER TO TRIM-TRIO CATALOG.
3. CONNECTOR TO BE MATED WITH UTG0247S

04

BS, A , 201178 , 001

GEN. ST.	01	02	03	04	05	06	07	08	0D	50	60	70	80	90																	
INT. ST.	10	11	12	13	14	18	20	31	32	33	34	38	39	40	42	43	44	45	46	48	56	70	72	73	75	76	81	82	83	84	88

1DEC ±0,2 1DEC 2DEC ±0,1 2DEC ANGLES ±1° HOEKEN	<b>APPR.</b> DRAFT CHECKED	<b>DATE</b> 26-9-90	<b>SIGN.</b> M BUEDS	<b>MALE PLUG</b> <b>CAT. No. UTG6247PN</b>	
WE RESERVE THE RIGHT TO CHANGE DIMENSIONS OR REQUIREMENTS WITHOUT PRIOR NOTICE.					SOURIAU Route Nationale 23 72470 CHAMPAGNE
ALL DIMENSIONS IN MM 				<b>REFERENCES / REFERENTIES</b>	
ALLE AFMETINGEN IN MM				BS, A , 201178 , 001 <b>NOT EXPORT CONTROLLED</b>	
DRAWING NR.		CUSTOMER DRAWING		REVISION	