



MAX24505, MAX24510

5 or 10 Output Any-Rate Clock Multipliers with Internal EEPROM

General Description

The MAX24505 and MAX24510 are flexible, high-performance clock multiplier/synthesizer ICs with two independent APLLs. Each APLL performs any-to-any frequency conversion. From any input clock frequency 9.72MHz to 750MHz these devices can produce frequency-locked APLL output frequencies up to 750MHz and as many as 10 differential output clock signals that are integer divisors of the APLL frequencies. Output jitter is typically 0.35 to 0.5ps RMS (12kHz to 20MHz) on all outputs and can be as low as 0.24ps RMS. Each device can configure itself from internal EEPROM so that clock signals are available immediately after power-up or reset.

Applications

Frequency Conversion and Synthesis Applications in a Wide Variety of Equipment Types

Ordering Information

PART	OUTPUTS	PIN-PACKAGE
MAX24505EXG+	5	81-CSBGA (10mm) ²
MAX24510EXG+	10	81-CSBGA (10mm) ²

Features

- ◆ **Input Clocks**
 - ◆ One Crystal or CMOS Input
 - ◆ Three Differential or CMOS Inputs
 - ◆ Differential to 750MHz, CMOS/TTL to 125MHz
 - ◆ Clock Selection By Pin or Register Control
- ◆ **Two APLLs Plus 5 or 10 Output Clocks**
 - ◆ APLLs Perform High Resolution Fractional-N Clock Multiplication
 - ◆ Any Output Frequency from <1Hz to 750MHz
 - ◆ Each Output Has an Independent Divider
 - ◆ Output Jitter 0.35 to 0.5ps RMS Typical on All Outputs, Can Be As Low As 0.24ps RMS
 - ◆ Outputs are CML or 2xCMOS, Can Interface to LVDS, LVPECL, HSTL, SSTL and HCSL
 - ◆ CMOS Output Voltage from 1.5V to 3.3V
- ◆ **General Features**
 - ◆ Automatic Self-Configuration at Power-Up from Internal EEPROM Memory
 - ◆ SPI™ Processor Interface
 - ◆ 1.8V + 3.3V Operation (5V Tolerant)
 - ◆ -40 to +85°C Operating Temp. Range

Block Diagram

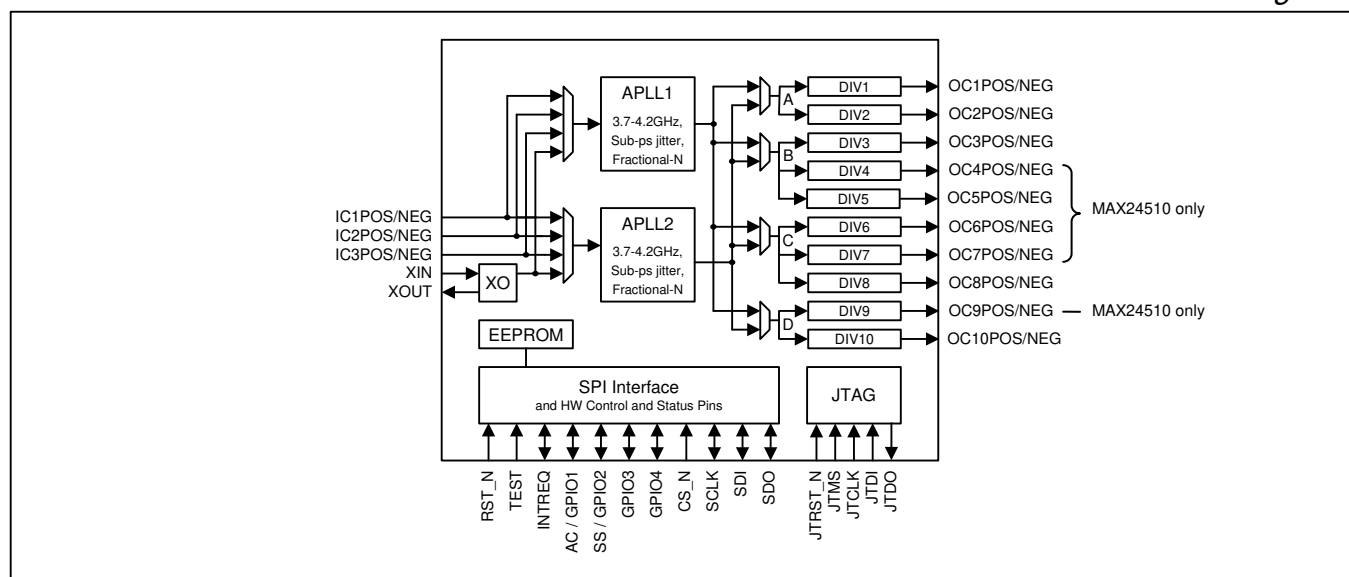

1. Application Examples

Figure 1-1. Asynchronous Ethernet Clocks

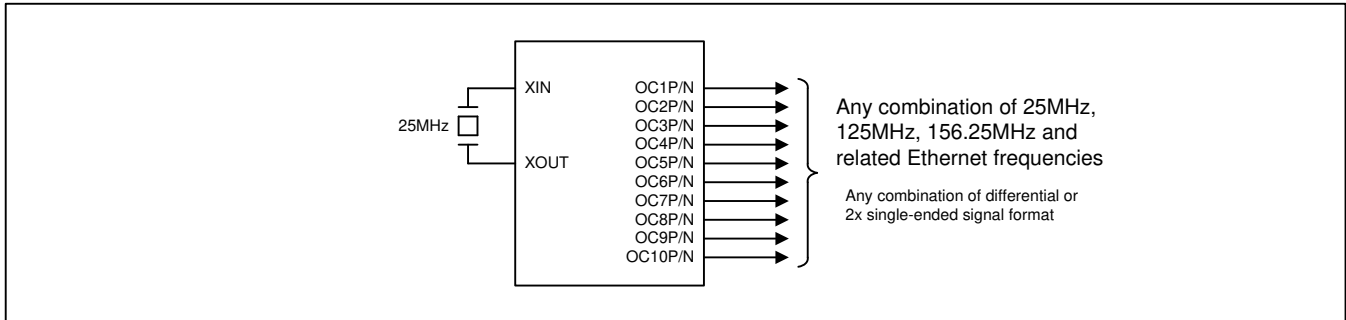
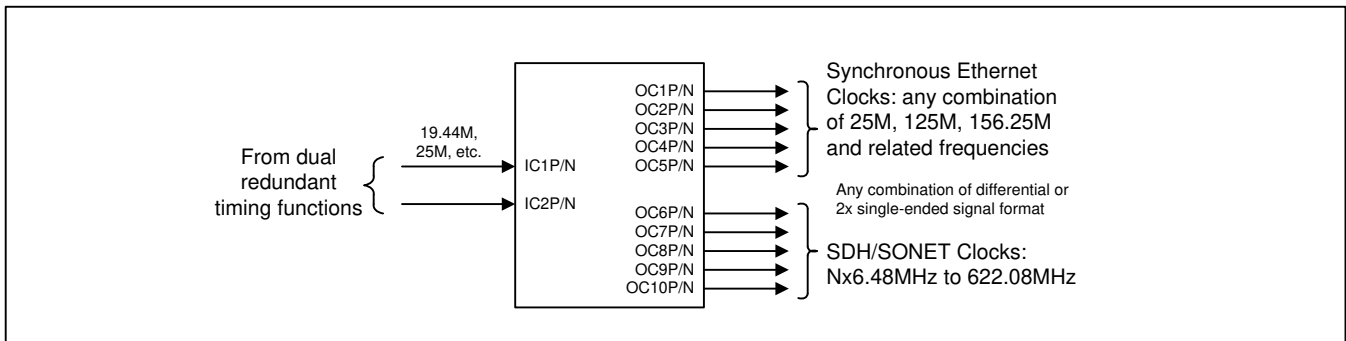

Figure 1-2. Synchronous Ethernet and SDH/SONET Line Card



2. Detailed Features

2.1 APLL Features

- Two independent APLLs
- Very high-resolution fractional scaling (i.e. non-integer multiplication)
- Output jitter is typically 0.35 to 0.5ps RMS and can be as low as 0.24ps RMS (12kHz to 20MHz)
- Telecom output frequencies include 622.08MHz for SONET/SDH and 625MHz for Synchronous Ethernet
- Bypass mode for each APLL supports system testing and allows the devices to be used in fanout applications

2.2 Output Clock Features

- Up to five (MAX24505) or ten (MAX24510) low-jitter output clocks
- Each output can be one differential output or two CMOS/TTL outputs
- Outputs easily interface with CML, LVDS, LVPECL, HSTL, SSTL, HCSL components
- Each output can be any integer divisor of an APLL output clock
- Supported telecom frequencies include PDH, SDH, Synchronous Ethernet, OTN
- Can also produce clock frequencies for microprocessors, ASICs, FPGAs and other components
- Per-output delay adjustment
- Per-output enable/disable

2.3 General Features

- SPI serial microprocessor interface
- Automatic self-configuration at power-up from internal EEPROM memory
- Four general-purpose I/O pins
- Register set can be write-protected
- Internal compensation for local oscillator frequency error



Microsemi Corporate Headquarters
One Enterprise, Aliso Viejo CA 92656 USA
Within the USA: +1 (949) 380-6100
Sales: +1 (949) 380-6136
Fax: +1 (949) 215-4996

Microsemi Corporation (NASDAQ: MSCC) offers a comprehensive portfolio of semiconductor solutions for: aerospace, defense and security; enterprise and communications; and industrial and alternative energy markets. Products include high-performance, high-reliability analog and RF devices, mixed signal and RF integrated circuits, customizable SoCs, FPGAs, and complete subsystems. Microsemi is headquartered in Aliso Viejo, Calif. Learn more at www.microsemi.com.

© 2012 Microsemi Corporation. All rights reserved. Microsemi and the Microsemi logo are trademarks of Microsemi Corporation. All other trademarks and service marks are the property of their respective owners.