

DRAWING MADE IN THIRD ANGLE PROJECTION

RELEASED FOR PUBLICATION JULY 9, 1982
 © COPYRIGHT 1982 BY AMP INCORPORATED, HARRISBURG, PA. ALL INTERNATIONAL RIGHTS RESERVED. AMP PRODUCTS MAY BE COVERED BY U.S. AND FOREIGN PATENTS AND/OR PATENTS PENDING.

LOC DIST
 BD 39

REVISIONS						
P	F	ZONE	LTR	DESCRIPTION	DATE	APPROVED
			0	RELEASED		
✓			0	REVISED ECN-0937	4-2-85	J6

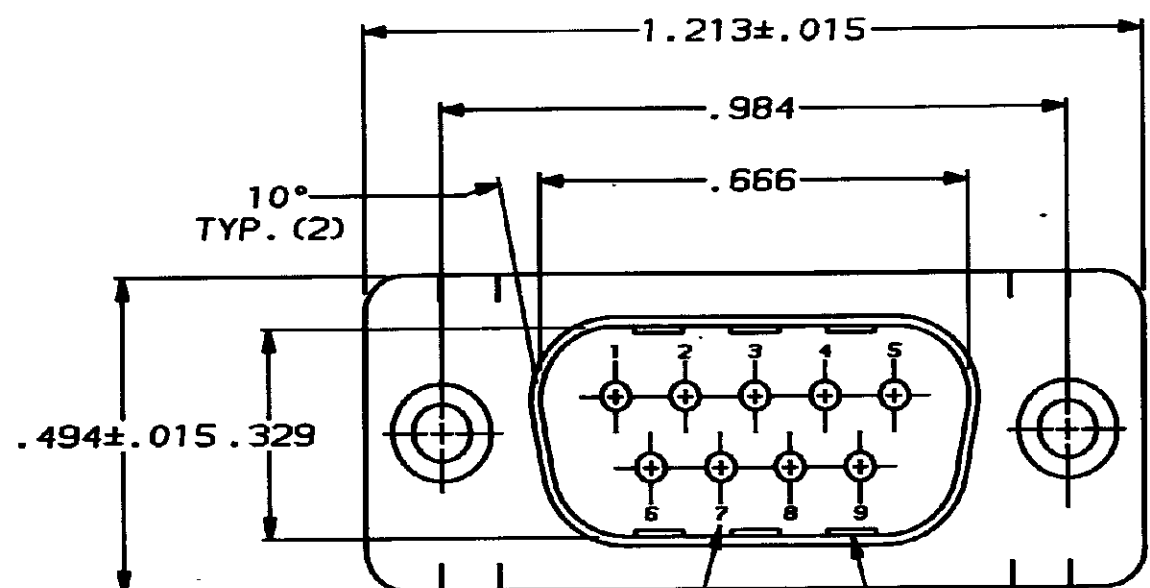

RAISED CAVITY IDENTIFICATION

GROUNDING INDENTS (FOR -2 ONLY)

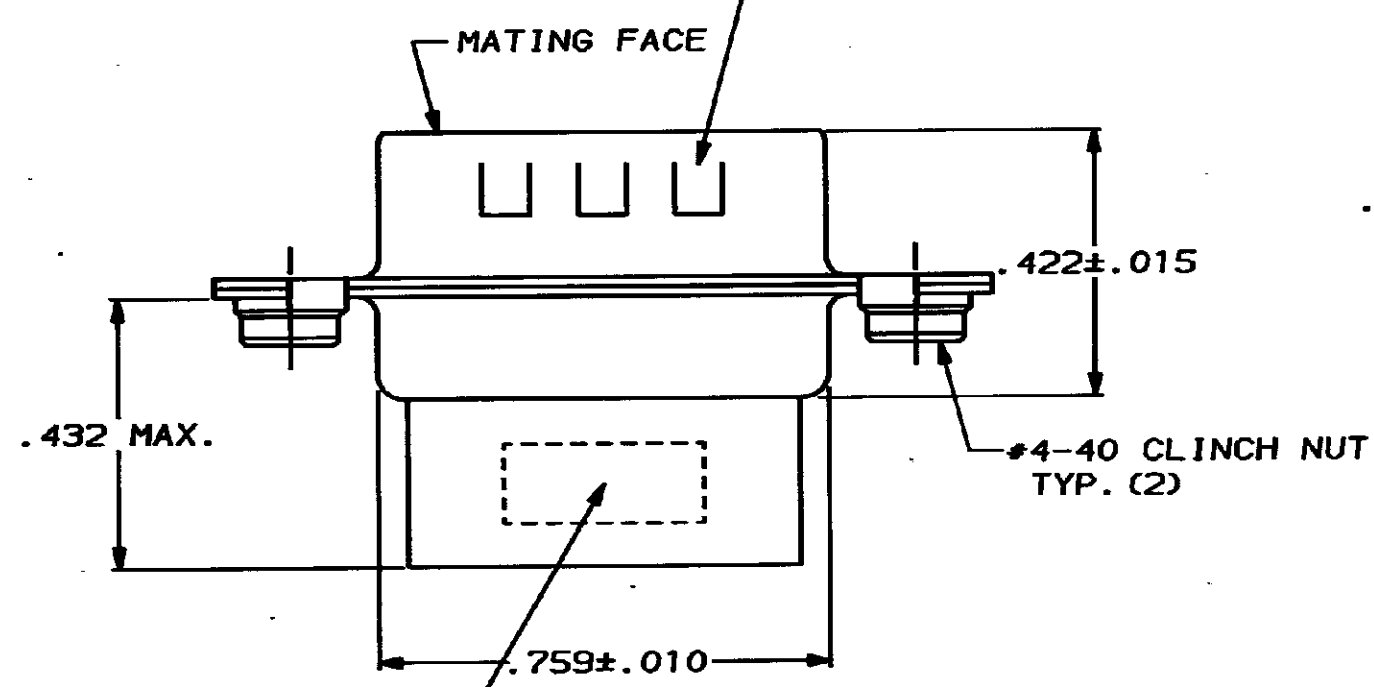

"AMP", PART NO. & DATE CODE, MARKED IN AREA INDICATED, ON FAR SIDE

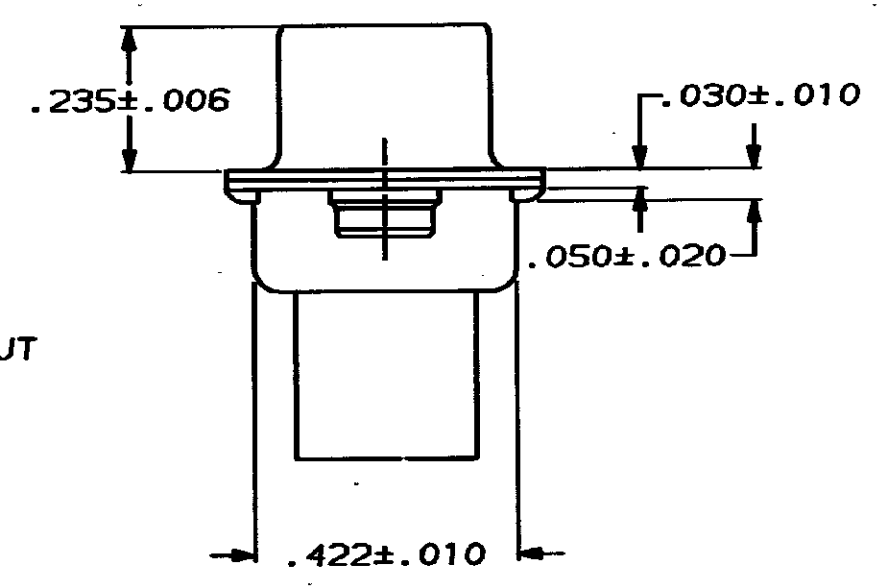

- CONNECTOR ACCEPTS SIZE 20 DF PIN CONTACTS, RETENTION TINES ARE AN INTEGRAL PART OF INSERT.
 - CONNECTOR COMPLIES WITH AMP SPEC. 108-40005 WHERE APPLICABLE.
- △ FLAME RETARDANT 94V-0 RATED THERMOPLASTIC; COLOR: BLACK.
 - △ STEEL PER ASTM A109.
 - △ TIN PLATED PER MIL-T-10727.

W/ GROUNDING INDENTS	745906-2
WO/ GROUNDING INDENTS	745906-1
REMARKS	PART NUMBER

UNLESS OTHERWISE SPECIFIED DIMENSIONS ARE IN INCHES. TOLERANCES ON: DECIMALS ±.005 ANGLES ± 2°	CONTRACT NO		AMP AMP INCORPORATED Harrisburg, Pa.	
	DR	J. GERACE 7-9-82		
	CHK	J. GERACE 7-9-82	NAME PLUG CONNECTOR, SIZE 1, 9 POS., W/ CLINCH NUTS, AMPLIMITE HDP	
	APPD	J. FULPONI 8-3-82		
MATERIAL MOLDED PARTS: △ SHELLS: △	APPD	E. GILL 8-4-82	DRAWING NO 745906	
FINISH SHELLS: △	DSGN APPD	OTHER APPD		SIZE C
SCALE			FSCN NO 00779	SHEET

CUSTOMER DRAWING

745906