



APPLICATION SPECIFICATION

71395 COPLANARITY MEASUREMENT GUIDELINES

1.0 SCOPE

This specification will define and document how to measure coplanarity of the 71395 dual row vertical SMT receptacle. It will also describe the floating terminal design used in this product and its affects on coplanarity results.

2.0 PRODUCT DESCRIPTION

Receptacle, dual row vertical surface mount top entry on .100" grid.

3.0 REFERENCE DOCUMENTS

- SDA-71395-0*** Customer Drawing (with .130" long pcb retention peg)
- SDA-71395-1*** Customer Drawing (with no pcb retention peg)
- SDA-71395-3*** Customer Drawing (with .080" long pcb retention peg)
- PS-71395 - Product specification
- PK-70873-0662 – Tray Packaging specification
- PK-71395-001 – Tape and Reel Packaging specification

4.0 NOMENCLATURE

Float = distance the terminal can move from the lower terminal retention surface to the upper retention surface

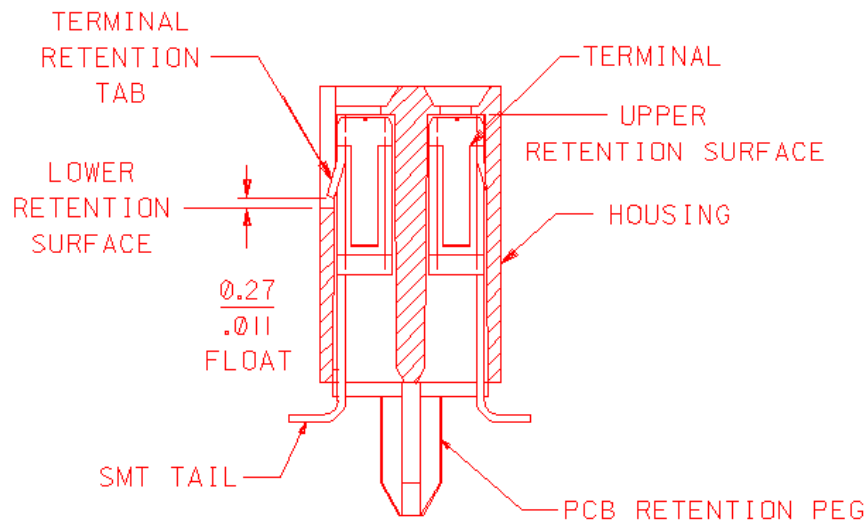

REVISION: B	ECR/ECN INFORMATION: EC No: UCP2004-1048 DATE: 2003 / 12 / 08	TITLE: APPLICATION SPECIFICATION DUAL ROW VERTICAL SURFACE MOUNT TOP ENTRY ON .100 GRID	SHEET No. 1 of 2
DOCUMENT NUMBER: AS-71395-001	CREATED / REVISED BY: BSMART	CHECKED BY: BBARKER	APPROVED BY: SMILLER



APPLICATION SPECIFICATION

5.0 COPLANARITY

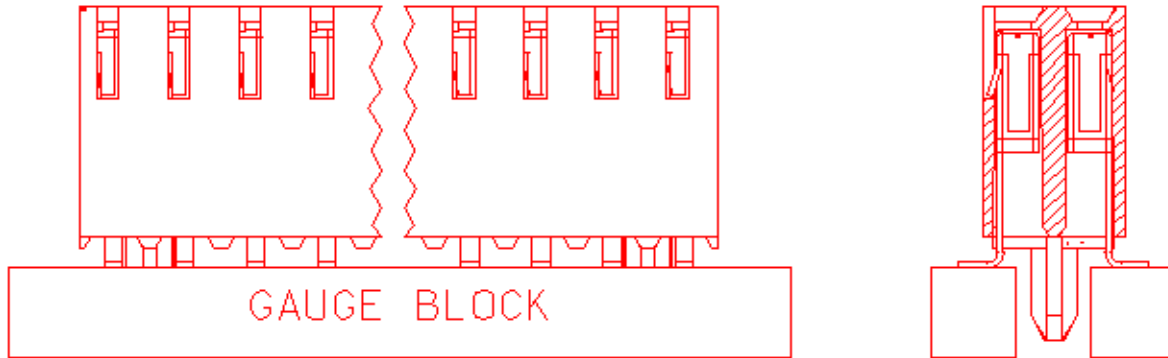

The Receptacle should be placed on a gauge block as shown. (If the receptacle does not have pcb retention pegs, only one gauge block is required.) The coplanarity can then be measured using an Optical Comparator. Zero out on the top edge of the gauge block and then measure to the bottom surface of the smt tail that is the highest off of the gauge block.

Note: the terminals in this receptacle are designed to float in the plastic housing. Removing the receptacle from the gauge block and subsequent restaging may result in different measurements due to this float.

The table below is the average coplanarity measurements of 28 parts, p/n 15-45-3580 which is an 80 circuit receptacle.

	Coplanarity	
	mm	In
Minimum	0.021	.0008
Maximum	0.082	.0032
Mean:	0.0485	.0019
Stdev (σ):	0.0172	.0007

6.0 SUMMARY:

With the floating terminal design coplanarity of 0.00 can be achieved. Frequently this occurs from the vibration of removing the product from its packaging and hand placing on the printed circuit board. Typically coplanarity is a requirement for surface mounted connectors however it is not a practical specification for floating terminal designs.

REVISION: B	ECR/ECN INFORMATION: EC No: UCP2004-1048 DATE: 2003 / 12 / 08	TITLE: APPLICATION SPECIFICATION DUAL ROW VERTICAL SURFACE MOUNT TOP ENTRY ON .100 GRID	SHEET No. 2 of 2
DOCUMENT NUMBER: AS-71395-001	CREATED / REVISED BY: BSMART	CHECKED BY: BBARKER	APPROVED BY: SMILLER